

---

# Contents

1 Finding a Place for the Printer . . . . .	2
2 Unpacking . . . . .	4
3 Installing the Imaging Cartridge . . . . .	5
4 Loading Paper . . . . .	8
5 Attaching the Power Cord . . . . .	9
6 Test Printing . . . . .	10
7 Connecting the Printer to Your Computer . . . . .	11
8 Installing the Printer Driver . . . . .	12
9 Making Basic Driver Settings . . . . .	16

This booklet will help you set up your printer and begin printing quickly. It also gives you instructions for routine maintenance. If you need detailed information on using the printer or if you have problems printing, see your *Reference Guide*.

EPSON is a registered trademark of Seiko Epson Corporation.

**General Notice:** *Other product names used herein are for identification purposes only and may be trademarks of their respective owners. EPSON disclaims any and all rights in those marks.*

Copyright © Seiko Epson Corporation 1996, Nagano, Japan.

This guide provides the basic information you need to use your EPL-N1200 with a PC running Microsoft® Windows® or DOS.

For more information about printing on special paper, using the printer's control panel, using the utilities that came with your printer, and other information that will help you get the results you want, see the *Reference Guide*.

---

# 1 Finding a Place for the Printer

- ❑ Place your printer close enough to the computer or workstation for the printer cable to reach both ends.
- ❑ Use a grounded outlet that matches the printer's power plug. Do not use an adapter plug.
- ❑ Leave adequate room around the printer to allow easy operation and maintenance and sufficient ventilation. The diagram below shows the recommended amount of space.
- ❑ If you install the optional lower paper cassette, you will need an additional 94 mm (3.7 inches) in height.
- ❑ If you install both optional lower paper cassettes, you will need an additional 195 mm (7.7 inches) in height.

100 mm (4") minimum each side

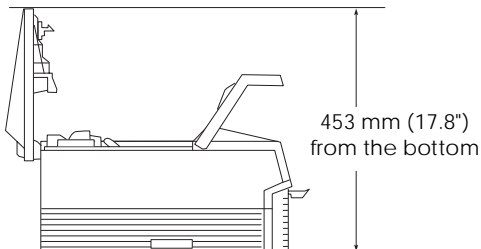
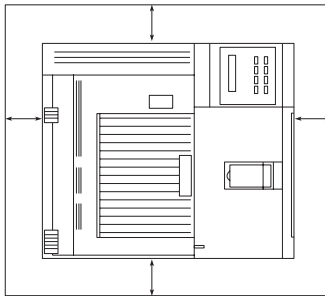



**Caution:**

- ❑ *Place the printer where you can easily unplug the power cord.*
- ❑ *Avoid locations that are subject to direct sunlight, excessive heat, moisture, or dust.*
- ❑ *Avoid using an electrical outlet that is controlled by wall switches or automatic timers. Accidental disruption of power can wipe out valuable information in your computer's and printer's memory.*
- ❑ *Avoid using outlets on the same circuit with large motors or other appliances that might disturb the power supply.*
- ❑ *Keep the entire computer and printer system away from potential sources of interference, such as loudspeakers or the base units of cordless telephones.*

---

## 2 Unpacking

1. Remove the accessories and printer from the shipping carton.

**Note:**

*The printer weighs about 15 kg (33.1 lbs) and should be lifted with care.*

2. Set the printer on a flat, stable surface.
3. Take the packaging material off the printer and the other items and store it for future use.
4. Make sure you have everything shown below.

printer

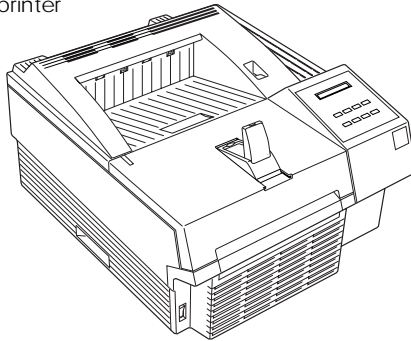

imaging cartridge

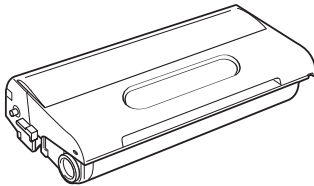

power cord

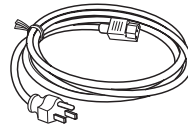

---

## 3 Installing the Imaging Cartridge



**Caution:**

- ❑ *Do not turn the imaging cartridge upside down. Do not expose the imaging cartridge to light any longer than necessary.*
- ❑ *Do not open the drum's protective cover and avoid exposing the imaging cartridge to room light any longer than necessary. Overexposing the cartridge may cause abnormally dark or light areas to appear on the printed page and reduce the life of the imaging cartridge.*

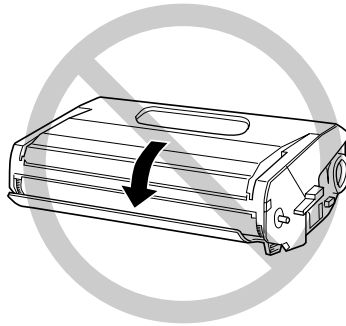

1. Pull the latch on the right toward you to open the printer cover.

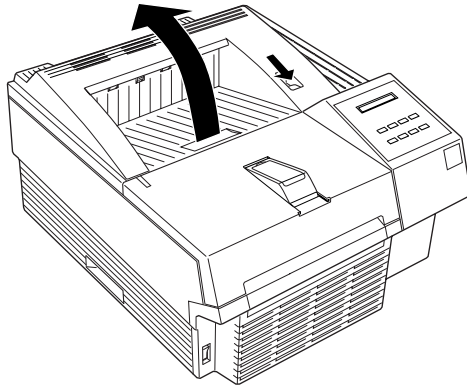

2. While holding the imaging cartridge horizontally, gently shake it a few times to distribute the toner evenly.

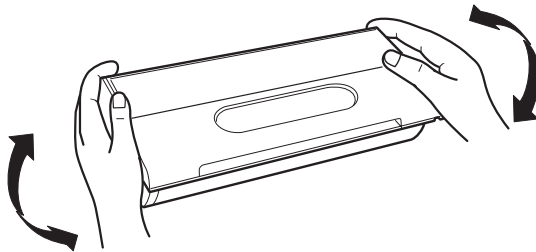

3. Set the imaging cartridge on a clean, flat surface. Firmly grip the tab on the left side of the imaging cartridge. Pull the clear seal all the way out with firm, even pressure as shown.

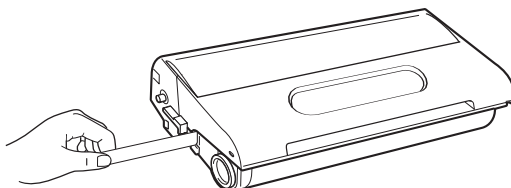

4. Hold the imaging cartridge and gently shake the cartridge from front to back.

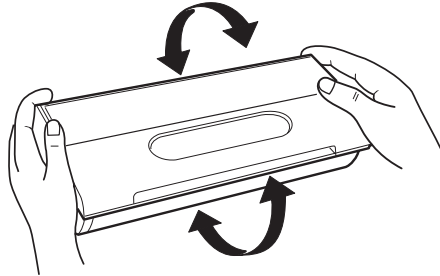

5. Insert the pins on each side of the imaging cartridge into the grooves inside the printer, and slide the cartridge gently into place.

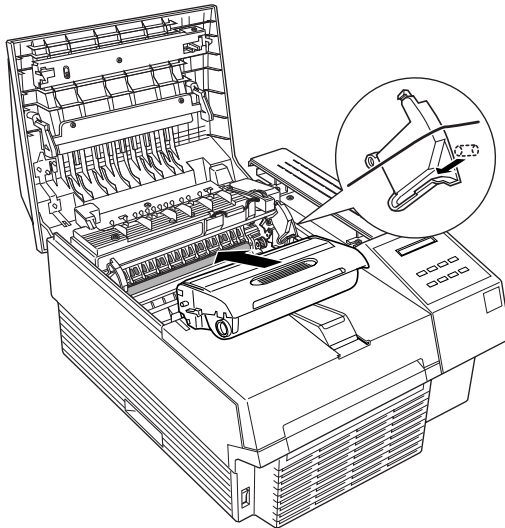

6. Gently press down on the printer cover until it clicks shut.



**Caution:**

*Never transport the printer with the imaging cartridge installed.*

---

## 4 Loading Paper

1. Fan a stack of paper (up to 250 sheets); then tap it on a flat surface to even up the edges.
2. Open the front cover.
3. Adjust the paper guides inside the MP (Multi Purpose) Tray to match the size of the paper. Load the stack of paper into the tray; make sure that the paper guides do not squeeze the paper.

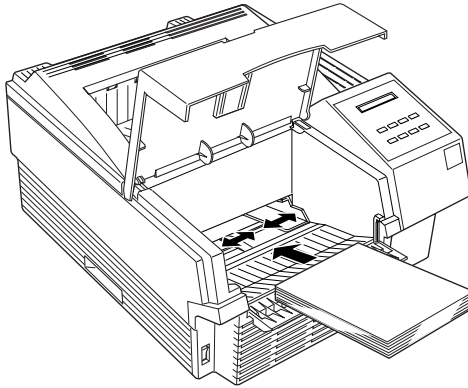

4. Close the front cover.

5. Slide the paper stopper to match the size of the paper you will print on.

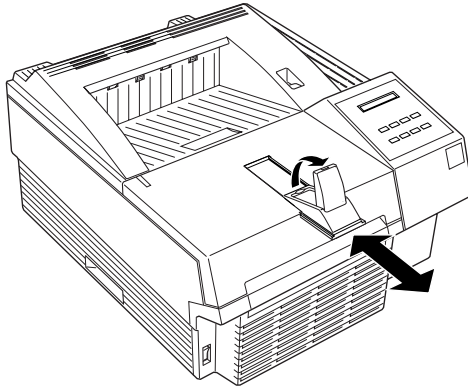

---

## 5 *Attaching the Power Cord*

1. Make sure the power switch at the front left of the printer is turned off.
2. Insert the power cord into the back of the printer. Then plug the other end into a properly grounded outlet.

## 6 Test Printing

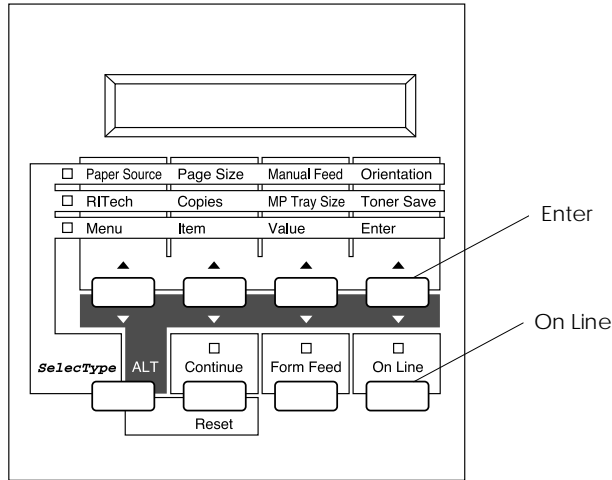

1. Make sure the imaging cartridge is installed. Turn on the printer. Several messages appear on the display as the printer performs internal tests. After about 60 seconds, the **Ready** message appears.
2. Make sure the **On Line** light is on; meaning the printer is ready to accept and print data. If it isn't on, press the **On Line** button.
3. Press the **Enter** button two times. The printer prints the status sheet, showing the current printer settings.

---

## 7 *Connecting the Printer to Your Computer*

This section tells you how to connect the printer to your computer using the Parallel B interface. However, you can connect up to four computers to your printer at the same time using other optional interfaces and the Parallel C interface. To learn which optional interfaces are supported and how to install them, see Chapter 4 in the *Reference Guide*. All interfaces connect in generally the same way as the Parallel B interface.

To connect the Parallel B interface, follow these steps:

1. Make sure both the printer and the computer are off.
2. Connect the parallel cable to the Parallel B interface connector.

**Note:**

*Use only a double-shielded, twisted-pair parallel cable.*

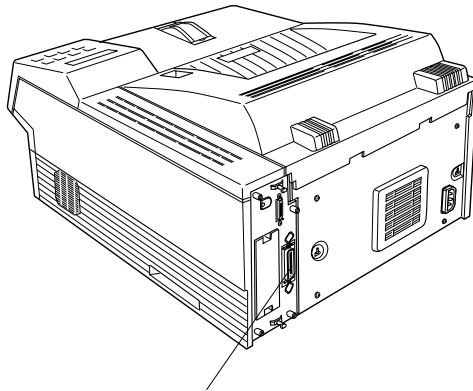

Parallel B interface connector

3. Secure the connector by squeezing the wire clips together until they lock in place on both sides of the connector.

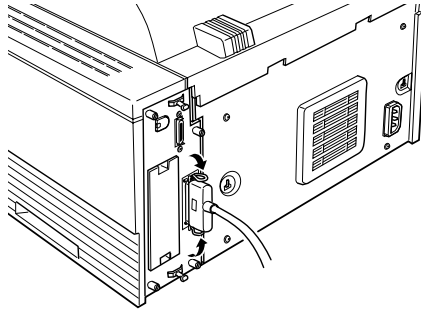

4. Connect the other end of the cable to your computer, and fasten it as required.
5. Turn on the printer and then turn on your computer.

---

## 8 *Installing the Printer Driver*

A printer driver allows your software program to control the operation of the printer by translating a document's margins, fonts, and other settings into control codes that the printer understands.

The floppy disk that comes with your printer contains a printer driver for Microsoft® Windows® 3.1, Windows 95, Windows NT. The Windows printer driver provides the best performance with your printer.

If you are running DOS or need a different emulation mode, you can use a driver other than the Windows driver included with the printer.

Your computer system must meet the following minimum requirements to use the Windows driver:

- ❑ Microsoft Windows 3.1, Windows 95, or Windows NT
- ❑ 7MB of free disk space on the hard drive for Windows 3.1 or Windows 95, or 9MB of free space for Window NT.

---

## *For Windows 95 Users*

Follow these steps to install the printer driver using Windows 95 plug-and-play capabilities:

**Note:**

*To install the driver using Windows 95 plug-and-play capabilities, your computer's parallel port must be an IEEE 1284 (ECP or EPP compatible) bidirectional parallel port. See your computer documentation for more information.*

1. Turn off your printer and computer, if necessary.
2. Turn on the printer first; then turn on the computer. Your computer begins loading Windows 95.
3. If you defined a password, enter it at the prompt. You see the New Hardware Found screen.

**Note:**

*If you do not see the New Hardware Found screen, see "For Windows 3.1 and Windows NT Users" below for installation instructions.*

4. Click the Driver from disk provided by hardware manufacturer button. Do not select any other buttons.

**Note:**

*The next time you turn on your computer after installing the driver, Windows 95 may display the New Hardware Found screen again. In this case, click the Do not install a driver radio button; then click OK. This screen does not appear again.*

5. Click OK. You see the Install From Disk screen.
6. Insert the Windows printer driver disk in a disk drive.
7. If you inserted the disk in drive A, click OK. Otherwise, change the driver letter in the Copy manufacture's files from box and click OK. The printer driver is installed automatically.
8. When installation is complete, click OK.

The printer driver is now installed on your computer.

---

## ***For Windows 3.1 and Windows NT Users***

Follow these steps to install the printer driver for Windows 3.1 or Windows NT:

1. Make sure Windows is running.
2. Insert the EPSON driver disk into drive A (or B).
3. Make sure the Program Manager window is open; then choose Run on the File menu.  
(For Windows 95 users: Click Start, then choose Run.)
4. Type A:\INSTALL.EXE (or B:\INSTALL.EXE); then click OK.
5. Select EPL-N1200 as the Printer Model and click OK. The printer driver is installed automatically.

6. When installation is complete, click OK.

The printer driver is now installed on your computer.

**Note:**

*Windows 3.1 and NT will now use the EPL-N1200 as the default printer. If you need to change the default printer or port assignment, use the Printers utility in the Control Panel.*

## **Selecting the driver for DOS programs**

Since application programs differ in their driver selection procedures, there is no standard way to select the printer driver. See your software manual for information on how to select the printer.

When asked to select a printer, pick the first printer available in the list below.

- EPL-N1200
- EPL-5600
- EPL-5500
- EPL-3000
- EPL-5200/5200+
- HP LaserJet III/IIIP/IIID
- HP LaserJet III Si
- HP LaserJet 4L
- EPL-9000
- HP LaserJet 4

If you choose a printer other than the EPL-N1200, you may not be able to use some printer features.

**Note:**

*The floppy disk packed with your printer contains the Remote Control Panel utility. When you are running DOS, you can use this utility to access the printer's control panel settings. For more information, see Chapter 5 in the Reference Guide.*

---

## 9 *Making Basic Driver Settings*

Before you start printing, you should make sure that the driver settings match your document requirements. While many Windows applications override the printer settings made with the driver, some do not.

Be sure to check the following:

- Graphics Resolution      The print resolution in dots per inch (dpi)
- Paper Format                The size of the paper loaded in the printer
- Orientation                 The direction of printing on the page (portrait or landscape)
- Paper Source                MP Tray, manual feed, or lower paper cassette

### **For Windows 3.1 and Windows NT users**

Follow these steps to access the driver and make the required settings:

1. In the Main window, double-click the Control Panel icon.
2. Double-click the Printers icon.
3. Make sure your printer is highlighted, and click the Setup button in the Print Setup menu.
4. Select the paper size you loaded in the printer from the Paper Size Format. If you don't see your paper size in the list, use the arrows on the right to scroll through the list. The diagram on the screen changes according to the paper size you select.

5. Select Portrait or Landscape orientation. The direction of printing on the diagram on the screen changes according to the orientation you select.
6. Select the paper source.
7. Select the resolution from the Graphics Resolution list.

### **For Windows 95 users**

Follow these steps to make the required settings:

1. Click the Start button.
2. Point to Settings; then click Printers.
3. Right-click your printer icon and choose Properties. Be sure to right-click.
4. Click the Details tab; then click the Setup button.
5. Select the paper size you loaded in the printer form the Paper Format list. If you don't see your paper size, use the arrows beside the list to find it; then select it. The diagram on the screen changes according to the paper size you select.
6. Select Portrait or Landscape orientation. The diagram on the screen changes according to the paper size you select.
7. Select the paper source.
8. Select the resolution from the Graphics Resolution list.

Make any other settings you wish, and click OK when you are finished.

