

# CHAPTER 2. ADJUSTMENTS

## [1] Adjustments

### General

Since the following adjustments and settings are provided for this model, make adjustments and/or setup as necessary.

### 1. Adjustments

#### Adjustments of output voltage (FACTORY ONLY)

1. Install the power supply unit in the machine.
2. Set the recording paper and document.
3. When the document is loaded, power is supplied to the output lines. Confirm that outputs are within the limits below.

#### Output voltage settings

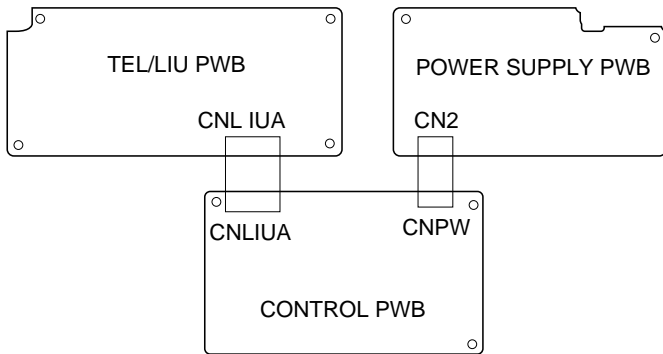

Output	Voltage limits
+5V	4.75V ~ 5.25V
+24V	24.0V ~ 26.0V

Connector No.	CNPW
Pin No.	
1	DG
2	+5V
3	MG
4	MG
5	+24V
6	+24V

### 2. IC protectors replacement

ICPs (IC Protectors) are installed to protect the motor driver circuit. ICPs protect various ICs and electronic circuits from an overcurrent condition.

The location of ICPs are shown below:

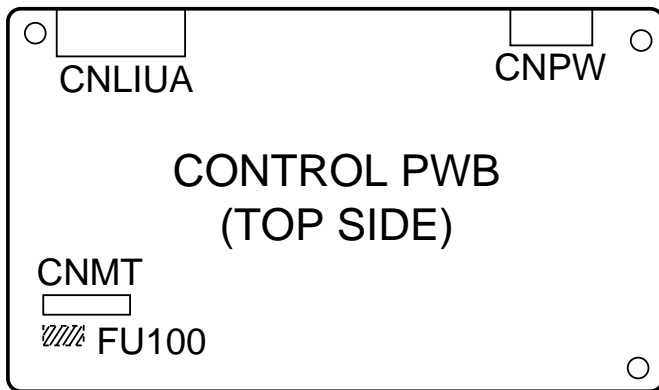

- (1) FU100 (KAB2402) is installed in order to protect IC's from an over-current generated in the motor drive circuit. If FU100 is open, replace it with a new one.

## 3. Settings

### Dial mode selector

DIAL mode (Soft Switch No. SWB4 DATA No. 2)

(step 1) Select "OPTION SETTING".

KEY: **FUNCTION** ④

DISPLAY: **OPTION SETTING** ↔ **PRESS ✕ OR #**

(step 2) Select "DIAL MODE".

KEY: Push **#** until "**DIAL MODE**" is indicated because the number of **#**'s changes by the model.

Cursor  
When initially registering, the mode shows 1=TONE. When registering again, the mode which was registered formerly is shown.

DISPLAY: **DIAL MODE** ↔ **1=TONE, 2=PULSE**

(step 3) Select, using "1" or "2".

KEY: ①

DISPLAY: **TONE SELECTED**

KEY: ②

DISPLAY: **PULSE SELECTED**

(step 4) End, using the "STOP" key.

KEY: STOP

### 4. Volume setting

You can adjust the volume of the speaker, ringer, and handset using the **VOLUME** key.

#### (1) Speaker

- ① Press the **SPEAKER** key.
- ② Press the **VOLUME** key one or more times to select the desired level.

The display will show:

**SPEAKER VOLUME**

- ③ Press the **SPEAKER** key once again to turn off the speaker.

#### (2) Handset

- ① Lift the handset.
- ② Press the **VOLUME** key to select the desired level.

The display will show:

**RECEIVER VOLUME**

- ③ Replace the handset.

• Note: The handset volume reverts to medium each time you hang up.

#### (3) Ringer

- ① Press the **VOLUME** key to select the desired volume. (Make sure the **SPEAKER** key has not been pressed and the handset is not lifted.)

The display will show:

**RINGER VOLUME**

- ② If you want to turn off the ringer, continue to press the **VOLUME** key until **RINGER OFF: OK?** appears in the display, and then press the **START** key.

## [2] Diagnostics and service soft switch

### 1. Operating procedure

#### (1) Entering the diagnostic mode

Press **FUNC** → **9** → **\*** → **8** → **#** → **7**, and the following display will appear.

ROM Ver. FZG0 X After 2 sec: DIAG MODE

FZG0 X

Then press the **START** key and country name selected by country select will appear. Select the desired item with the **\*** key or the **#** key or select with the direct key. Enter the mode with the **START** key.

(Diag. specifications)

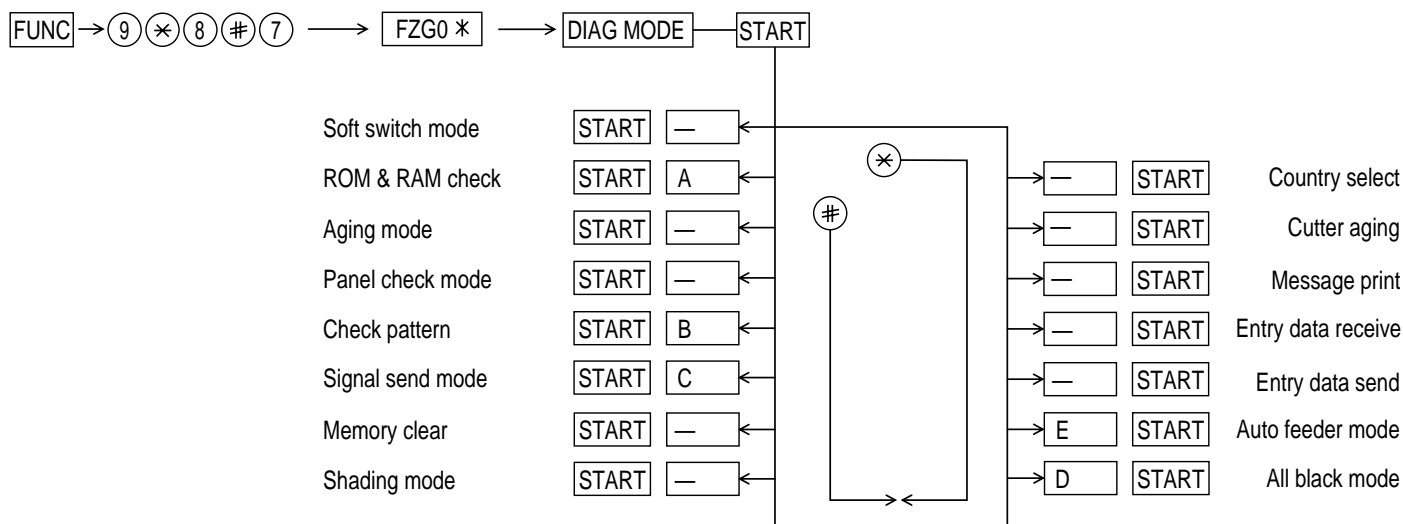

If the diag mode cannot be set, repeat the diag mode operation, performing the following operation.

After the power is turned on and "WAIT A MOMENT" is indicated, press the **STOP** key.

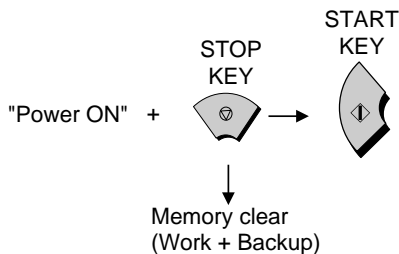

In relation with the process response (request from Production Engineering) "WAIT A MOMENT" clock indication may appear depending on **STOP** key timing. If the **STOP** key is held down, "MEMORY CLEAR?" appears.

### 2. Diagnostic items

ITEM No.	DIRECT key	Contents	Function
1	—	SOFT SWITCH MODE	Soft switches are displayed and changed. List can be output.
2	A	ROM & RAM CHECK	ROM is sum-checked, and RAM is matched. Result list is output.
3	—	AGING MODE	10 sheets of check patterns are output every 5 minutes per sheet.
4	—	PANEL CKECK MODE	Panel keys are tested. Result list is output.
5	B	CHECK PATTERN	2 sheets of check patterns are output.
6	C	SIGNAL SEND MODE	Various signals of FAX communication are output.
7	—	MEMORY CLEAR	Back-up memory is cleared, and is set at delivery.
8	—	SHADING MODE	Shading compensation is performed in this mode.
9	D	ALL BLACK PRINT	To check the print head, whole dots are printed over the interval of 2 m.
10	E	AUTO FEEDER MODE	Insertion and discharge of document are tested.
11	—	ENTRY DATA SEND	Registered content is sent.
12	—	ENTRY DATA RECEIVE	Registered content is received, and its list is output.
13	—	MESSAGE PRINT	The display message of each language is printed out together with the English equivalent.
14	—	CUTTER AGING	Recording paper is successively cut.
15	—	COUNTRY SELECT	The software parameter that it agreed in each country name is set up.

### 3. Diagnostic items description

#### 3. 1. Soft switch mode

The soft switches are provided so that each operation mode can be set by using the operation panel.

In this mode, these switches can be checked and set.

The contents of these switches are backed up.

The available soft switches are SW-A1 to SW-K1.

The content of soft switches is shown in page 2-5 to 2-17.

The contents are set to factory default settings.

#### 3. 2. ROM & RAM check

ROM executes the sum check, and RAM executes the matching test. The result will be notified with the number of short sounds of the buzzer as well as by printing the ROM & RAM check list.

Number of short sounds of buzzer 0 → No error

1 → ROM error

2 → RAM error (32Kbyte)

#### 3. 3. Aging mode

If any document is first present, copying will be executed sheet by sheet. If no document is present, the check pattern will be printed sheet by sheet. This operation will be executed at a rate of one sheet per 5 minutes, and will be ended at a total of 10 sheets.

#### 3. 4. Panel check mode

This mode is used to check whether each key operates properly or not. Press the key on the operation panel, and the key will be displayed on the display. Therefore, press all keys. At this time, finally press the STOP key.

When the STOP key is pressed, the keys which are not judged as "pressed" will be printed on the result list.

- LED part of the contact image sensor (CIS) is kept on during the term from when "START" of the panel test mode to end with the STOP key.

#### 3. 5. Check pattern

This mode is used to check the status of print head. Two sheets of check pattern are printed. The following information of check pattern is printed.

- |  |               |
|--|---------------|
| ① Vertical stripes (alternate white and black lines) | Approx. 35 mm |
| ② Full black   | Approx. 70 mm |
| ③ Full white   | Approx. 35 mm |

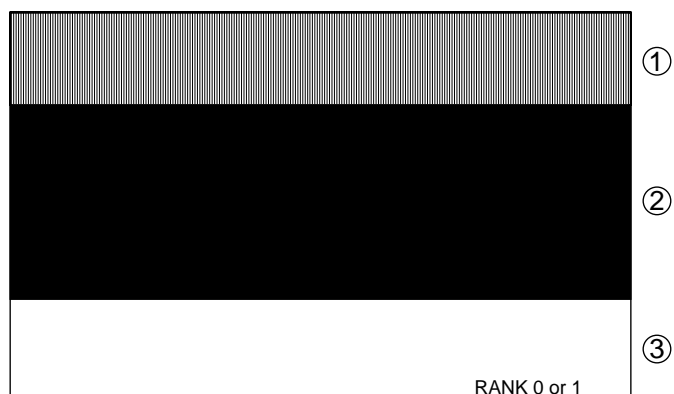

Note:

There is a selection RANK 0 or 1 depending on resistance value of the thermal head. RANK 0 or RANK 1 is printed at the tail of check pattern to identify.

#### 3. 6. Signal send mode

This mode is used to send various signals to the circuit during FAX communication. Every push of START key sends a signal in the following sequence. Moreover, the signal sound is also output to the speaker when the line monitor of the soft switch is on.

- [1] No signal (CML signal turned on)
- [2] 9600bps
- [3] 7200bps
- [4] 4800bps
- [5] 2400bps
- [6] 300bps (FLAG)
- [7] 2100Hz (CED)
- [8] 1100Hz (CNG)
- [9] Pseudo Ring (models with auto TEL/FAX changeover function)
- [10] END

#### 3. 7. Memory clear

This mode is used to clear the backup memory and to reset to the factory default settings.

The content of each setting will be cleared.

Note: Be sure to execute the memory clear mode whenever you change the country select setting. The default settings of the soft switches vary according to the destinations. Therefore, if you do not execute the memory clear after changing the country select setting, some functions may not work.

#### 3. 8. Shading mode

The mode is used for the shooting compensation. For reading, set up the special original paper.

The shooting compensation memorizes the reference data of white and black for reading.

Moreover, the memorized data is not erased even if memory clear mode is executed.

#### 3. 9. All black print

This mode is used to check the state of the printing head and intentionally overheat it. Whole dots are printed over the interval of 2 m. If it is overheated or the printing sheet is jammed, press STOP key for the end.

#### 3. 10. Auto feeder mode

In this mode, a document is inserted and discharged to check the auto feed function.

After this mode is started, set a document, and the document feed will be automatically tested.

#### 3. 11. Entry data send

This mode is used to send the registered data to the other machine and to make the other machine copy the registered content. Before sending in this mode, it is necessary to set the other machine at the entry data receive mode.

The contents to be sent are as follows (the machine prints each list after the transmission has completed):

- 1. Telephone list data
- 2. Sender (cover sheet) register data
- 3. Optional setting content
- 4. Soft switch content
- 5. Junk fax number list
- 6. Country setting content

### 3. 12. Entry data receive

This mode is used to receive the registered data from the other machine and to make your machine register the received data. Before receiving in this mode, it is necessary to set the other machine at the entry data send mode.

After receiving is completed, the machine prints the following lists:

1. Telephone list data
2. Soft switch list
3. Junk fax number list

### 3. 13. Message print

In this mode, all the message data, which are used for displaying indication and list print, are printed as a contrast table of the selected language and English.

### 3. 14. Cutter aging

This mode is used to consecutively cut the recording paper about 10 mm long and to display the number of cutting times.

(The number of cutting times is cumulatively counted unless you execute the memory clear.)

The operation is stopped in the following cases:

1. Hold down the stop key. (The cutter aging is stopped.)
2. No recording paper. (The cut operation is stopped.)
3. Recording paper jam. (The cut operation is stopped.)

## 4. How to make soft switch setting

To enter the soft switch mode, press the following key entries in sequence.

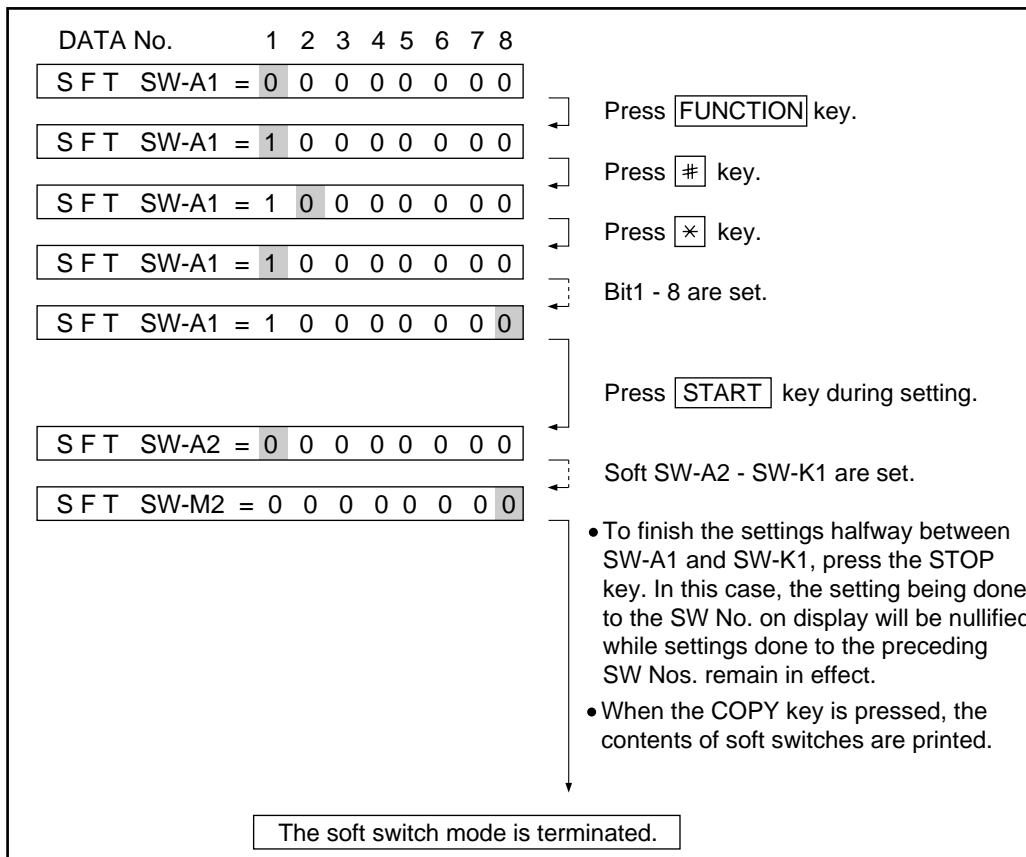
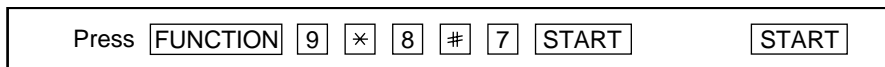

### 3. 15. Country select

This mode is used to set line connecting parameters which correspond to each destination.

When the country select mode is selected, and then the START key is pressed, the destination (country name) currently set will be displayed. By pressing the # or \* key, selectable destinations (country names) are displayed. When the destination (country name) you want to choose is displayed, press the START key. Each parameter will be stored in RAM.

Destinations (Country names) you can select are as follows:

COUNTRY	( )	COUNTRY CODE
U. S. A	(U)	00
CANADA	(C)	01
LATIN AMERICA (LA/LU)		02
ARGENTINA	(AR)	03

Note: Be sure to execute the memory clear mode whenever you change the country select setting. The default settings of the soft switches vary according to the destinations. Therefore, if you do not execute the memory clear after changing the country select setting, some functions may not work.

Do not set a country select setting which is different from that of the destination of the machine. Some functions will not work because the function and the PWB specifications are different.

5. Soft switch description

• Soft switch

SW NO.	DATA NO.	ITEM	Switch setting and function				Initial setting	Remarks	
			1		0				
SW I A1	1	Protect from echo	No		Yes		0		
	2	Forced 4800bps reception	Yes		No		0		
	3	Footer Print	Yes		No		0		
	4	Length limitation of copy/send/receive	No limit		Copy/Send:60cm Receive:1.5m		0		
	5	CSI transmission	Not transmitted		Transmitted		0		
	6	DIS receive acknowledgement during G3 transmission	Twice		NSF:Once DIS:Twice		0		
	7	Non modulated carrier for V29 transmission mode	Yes		No		0		
	8	Reserved					1		
SW I A2	1 2 3 4	Modem speed			V.29		V.27 ter		0 0 0 1
					9600bps	7200bps	4800bps	2400bps	
			No. 1	0	0	0	0		
			No. 2	0	0	0	0		
			No. 3	0	1	1	0		
			No. 4	1	1	0	0		
	5	Reserved					1		
	6	H2 mode	No		Yes		0		
7	Communication error treatment in RTN sending mode(Reception)	No communication error		Communication error		0			
8	CNG transmission	No		Yes		0			
SW I A3	1 2	CED tone signal interval			1000ms	750ms	500ms	75ms	0 0
			No. 1	1	1	0	0		
			No. 2	1	0	1	0		
	3	MR Coding	No		Yes		0		
	4	Reserved					0		
	5	Reserved					0		
	6	Reserved					0		
	7	Reserved					0		
8	Reserved					0			
SW I A4	1	Signal Transmission level (0~-31 dBm setting by 1dBm step)	Binary input				0		
	2		No. = 16 8 4 2 1				1		
	3		1 2 3 4 5				0		
	4		0 1 0 1 0				1		
5					0				
6	Protocol monitor(Error print)	Printed at com. error		Not printed		0			
7	Protocol monitor	Yes		No		0			
8	Line monitor	Yes		No		0			
SW I A5	1 2	Digital equalization setting(Reception)			7.2km		0km		1 1
			No. 1	1	0				
			No. 2	1	0				
	3 4	Digital equalization setting(Transmitter)			7.2km		0km		0 0
			No. 3	1	0				
			No. 4	1	0				
	5 6	Digital equalization setting(Reception for Caller ID)			7.2km		0km		0 0
			No. 5	1	0				
		No. 6	1	0					
7	Error criterion	10 ~ 20 %		5 ~ 10 %		0			
8	Anti junk fax check	Yes		No		1			

SW NO.	DATA NO.	ITEM	Switch setting and function					Initial setting	Remarks
			1		0				
SW I A6	1	Auto gain control(MODEM)	Enable		Disable			1	
	2	End Buzzer	Yes		No			1	
	3	Disconnect the line when DIS is received in RX mode	No		Yes			1	
	4	Equalizer freeze control(MODEM)	On		Off			0	
	5	Equalizer freeze control 7200 bps only	No		Yes			0	
	6	CNG transmission in manual TX mode	Yes		No			1	
	7	Initial compression scheme for sharp fax in TX mode	MR mode		H2 mode			0	
	8	Modem speed automatic down when RX level is under -40dBm	Yes		No			0	
SW I A7	1	EOL detect timer		5 seconds	13 seconds	20 seconds	25 seconds	0	
	2		No. 1	0	0	1	1		
	3		No. 2	0	1	0	1		
	4	Reserved						0	
	5	Reserved						0	
	6	Reserved						0	
	7	Reserved						0	
	8	Reserved						0	
SW I B1	1	Hold key	Enable		Disable			1	
	2	Auto dial fax transmission by REDIAL key	Yes		No			0	
	3	Reserved						0	
	4	Recall interval (0~15.5min setting by 0.5min step)	Binary input					0	
	5		No. =	16	8	4	2	1	
	6			4	5	6	7	8	
	7			0	1	0	1	0	
	8							0	
SW I B2	1	Recall times(0~15times setting)	Binary input					0	
	2		No. =	8	4	2	1		
	3			1	2	3	4		
	4			0	0	1	0		
	5	Dial tone detection(Before auto dial)	No		Yes			1	
	6	Reserved						0	
	7	Busy tone detection(After auto dial)	No		Yes			0	
	8	Busy tone detection pulse number (After auto dial)	4 pulses		2 pulses			0	
SW I B3	1	Waiting time after dialing		45 seconds	55 seconds	90 seconds	140 seconds	0	
	2		No. 1	0	0	1	1		
	3		No. 2	0	1	0	1		
	4	Reserved						0	
	5	Reserved						0	
	6	Reserved						0	
	7	Reserved						0	
	8	Reserved						0	
SW I B4	1	Dial pausing(sec/pause)	4 sec		2 sec			0	
	2	Dial mode	Tone		Pulse			1	OPTION
	3	Pulse → Tone change function by ✕ key	Enable		Disable			0	
	4	Dial pulse make/break ratio(%)	40/60		33/67			1	
	5	Auto dial mode Delay timer of before line connect		0 second	1.5 seconds	3.0 seconds	4.5 seconds	0	
	6		No. 5	0	0	1	1		
	7		No. 6	0	1	0	1		
	8	Reserved						0	

SW NO.	DATA NO.	ITEM	Switch setting and function										Initial setting	Remarks
			1					0						
SW   B5	1 2 3	Auto dial mode Delay timer of after line connect		1.7s	2.0s	2.5s	3.0s	3.6s	4.0s	5.5s	7.0s	0 0 0		
			No.1	0	0	0	0	1	1	1	1			
			No.2	0	0	1	1	0	0	1	1			
		No.3	0	1	0	1	0	1	0	1				
	4	Fax signal detection after telephone mode dial	Yes					No					0	
	5	Recalling fixed only one time when dialing was unsuccessful without detecting busy tone signal	Yes					No					1	
	6	Reserved											0	
	7	Reserved											0	
8	Reserved											0		
SW   B6	1 2 3 4 5	DTMF signal transmission level (Low frequency 0~15.5dBm setting by 0.5dBm step)	Binary input										0	
			No. = 16 8 4 2 1										1	
			1 2 3 4 5										1	
			0 1 1 0 0										0	
													0	
	6	Reserved											0	
	7	Reserved											0	
	8	Reserved											0	
SW   B7	1 2 3 4 5	DTMF signal transmission level (High frequency 0~15.5dBm setting by 0.5dBm step)	Binary input										0	
			No. = 16 8 4 2 1										1	
			1 2 3 4 5										0	
			0 1 0 0 1										0	
													1	
	6	Reserved											0	
	7	Reserved											0	
	8	Reserved											0	
SW   C1	1 2	Reading Slice(Binary)		Factory setting	Dark	Light	Daker in dark	0 0						
			No.1	0	0	1	1							
		No.2	0	1	0	1								
	3 4	Reading Slice(Half tone)		Factory setting	Dark	Light	Daker in dark	0 0						
			No.3	0	0	1	1							
		No.4	0	1	0	1								
	5	Line density selection	Fine					Standard					0	
	6	Reserved											0	
7	MTF correction in half tone mode	No					Yes					0		
8	Reserved											0		
SW   D1	1 2 3 4	Number of rings for auto receive (0~15rings setting)	Binary input										0	OPTION
			No. = 8 4 2 1										1	
			1 2 3 4										0	
			0 1 0 0										0	
	5	Automatic swiching manual to auto receive function	Yes					No					0	
	6 7	CI detect frequency		As PTT	11.5Hz	13.0Hz	20.0Hz	0 0						
			No.6	0	0	1	1							
		No.7	0	1	0	1								
8	Reserved											0		

SW NO.	DATA NO.	ITEM	Switch setting and function						Initial setting	Remarks		
			1			0						
SW D2	1 2 3	Distinctive ringing setting			USA/ Canada	USA/ Canada	USA/ Canada	USA/ Canada	Canada	Canada	0 0 0	OPTION
				OFF	Std.	Pat.1	Pat.2	Pat.3	Pat.4	Pat.5		
			No. 1	0	0	0	0	1	1	1		
	No. 2	0	0	1	1	0	0	1				
	No. 3	0	1	0	1	0	1	0				
	4	Reserved									0	
	5	Reserved									0	
	6	Caller ID function	Yes			No					0	OPTION
7	Reserved									0		
8	Reserved									0		
SW D3	1	CI off detection timer	Binary input						0			
	2	(0~1550ms setting by 50ms step)	No. =	16	8	4	2	1	1			
	3			1	2	3	4	5	1			
	4			0	1	1	1	0	1			
	5								0			
	6	Reserved							0			
	7	Reserved							0			
	8	Reserved							0			
SW D4	1	DTMF type Caller ID RX level	Binary input						1			
	2	(0~44dBm setting by 1dBm step)	No. =	32	16	8	4	2	1	0		
	3			1	2	3	4	5	6	1		
	4			1	0	1	1	0	0	1		
	5								0			
	6								0			
	7	Reserved							0			
	8	Reserved							0			
SW E1	1	Reserved							0			
	2	Reserved							0			
	3	Reserved							0			
	4	Reserved							0			
	5	Reserved							0			
	6	Reserved							0			
	7	Reserved							0			
	8	Reserved							0			
SW E2	1	Reserved							0			
	2	Reserved							0			
	3	Reserved							0			
	4	Reserved							0			
	5	Reserved							0			
	6	Reserved							0			
	7	Reserved							0			
	8	Reserved							0			
SW E3	1	Reserved							0			
	2	Reserved							0			
	3	Reserved							0			
	4	Reserved							0			
	5	Reserved							0			
	6	Reserved							0			
	7	Reserved							0			
	8	Reserved							0			

SW NO.	DATA NO.	ITEM	Switch setting and function					Initial setting	Remarks
			1		0				
SW   F1	1	DTMF detection time		50ms	80ms	100ms	120ms	0	
			No. 1	0	0	1	1		
	2						0		
		No. 2	0	1	0	1			
	3	Protection of remote reception(5××) detection	Yes		No			1	
	4	Remote reception with GE telephone	Compatible		Not compatible			1	
	5	Remote operation code figure by external	Binary input					0	
	6	TEL (0-9)	No. =	8	4	2	1	1	
7			5	6	7	8	0		
8			0	1	0	1	1		
SW   F2	1	CNG detection in STAND-BY mode	Yes		No			0	
	2	Number of CNG detect(AM mode)		1 pulse	2 pulses	3 pulses	4 pulses	0	
			No. 2	0	0	1	1		
	3		No. 3	0	1	0	1	1	
	4	Number of CNG detect(STAND-BY mode)		1 pulse	2 pulses	3 pulses	4 pulses	0	
			No. 4	0	0	1	1		
	5		No. 5	0	1	0	1	1	
	6	Reserved						0	
7	Reserved						0		
8	Reserved						0		
SW   G1	1	Reserved						0	
	2	Reserved						0	
	3	Reserved						0	
	4	Reserved						0	
	5	Reserved						0	
	6	Reserved						0	
	7	Reserved						0	
	8	Reserved						0	
SW   G2	1	Reserved						0	
	2	Reserved						0	
	3	Reserved						0	
	4	Reserved						0	
	5	Reserved						0	
	6	Reserved						0	
	7	Reserved						0	
	8	Reserved						0	
SW   G3	1	Reserved						0	
	2	Reserved						0	
	3	Reserved						0	
	4	Reserved						0	
	5	Reserved						0	
	6	Reserved						0	
	7	Reserved						0	
	8	Reserved						0	
SW   G4	1	Reserved						0	
	2	Reserved						0	
	3	Reserved						0	
	4	Reserved						0	
	5	Reserved						0	
	6	Reserved						0	
	7	Reserved						0	
	8	Reserved						0	

SW NO.	DATA NO.	ITEM	Switch setting and function		Initial setting	Remarks
			1	0		
SW I H1	1	Reserved			0	
	2	Reserved			0	
	3	Reserved			0	
	4	Reserved			0	
	5	Reserved			0	
	6	Reserved			0	
	7	Reserved			0	
	8	Reserved			0	
SW I H2	1	Reserved			0	
	2	Reserved			0	
	3	Reserved			0	
	4	Reserved			0	
	5	Reserved			0	
	6	Reserved			0	
	7	Reserved			0	
	8	Reserved			0	
SW I I1	1	Reserved			0	
	2	Reserved			0	
	3	Reserved			0	
	4	Reserved			0	
	5	Reserved			0	
	6	Reserved			0	
	7	Reserved			0	
	8	Reserved			0	
SW I I2	1	Reserved			0	
	2	Reserved			0	
	3	Reserved			0	
	4	Reserved			0	
	5	Reserved			0	
	6	Reserved			0	
	7	Reserved			0	
	8	Reserved			0	
SW I I3	1	Reserved			0	
	2	Reserved			0	
	3	Reserved			0	
	4	Reserved			0	
	5	Reserved			0	
	6	Reserved			0	
	7	Reserved			0	
	8	Reserved			0	
SW I I4	1	Reserved			0	
	2	Reserved			0	
	3	Reserved			0	
	4	Reserved			0	
	5	Reserved			0	
	6	Reserved			0	
	7	Reserved			0	
	8	Reserved			0	

SW NO.	DATA NO.	ITEM	Switch setting and function					Initial setting	Remarks
			1		0				
SW I5	1	Reserved						0	
	2	Reserved						0	
	3	Reserved						0	
	4	Reserved						0	
	5	Reserved						0	
	6	Reserved						0	
	7	Reserved						0	
	8	Reserved						0	
SW I6	1	Reserved						0	
	2	Reserved						0	
	3	Reserved						0	
	4	Reserved						0	
	5	Reserved						0	
	6	Reserved						0	
	7	Reserved						0	
	8	Reserved						0	
SW I7	1	Reserved						0	
	2	Reserved						0	
	3	Reserved						0	
	4	Reserved						0	
	5	Reserved						0	
	6	Reserved						0	
	7	Reserved						0	
	8	Reserved						0	
SW I8	1	Reserved						0	
	2	Reserved						0	
	3	Reserved						0	
	4	Reserved						0	
	5	Reserved						0	
	6	Reserved						0	
	7	Reserved						0	
	8	Reserved						0	
SW J1	1	Sender's phone number setting	Cannot change		Change allowed			0	
	2	Summer time setting (Daylight saving)	No		Yes			1	OPTION
	3	Ringer volume		Off	Low	Middle	High	1	OPTION
	4		No. 3	0	0	1	1		
	5	Speaker volume		Low	Low	Middle	High	1	OPTION
	6		No. 4	0	1	0	1		
	7		No. 5	0	0	1	1		
	8	Reserved						0	
SW J2	1	Handset receiver volume		Middle	Middle	Middle	High	1	OPTION
	2		No. 1	0	0	1	1		
	3	Reserved						0	
	4	Reserved						0	
	5	Reserved						0	
	6	Reserved						0	
	7	Reserved						0	
	8	Reserved						0	

SW NO.	DATA NO.	ITEM	Switch setting and function				Initial setting	Remarks	
			1		0				
SW I J3	1	Communication results printout (Transaction report)	Err/Tmr/M	Send only	Always	No print	0		
			No. 1	0	0	0			0
			No. 2	0	0	1			1
	3			No. 3	0	1	0	1	
	4	Time format	12 hour		24 hour		1		
	5	Date format	Month-Day-Year		Day-Month-Year		1		
	6	Reserved					0		
	7	Reserved					0		
8	Reserved					0			
SW I K1	1	Entering diag mode by pressing SPEED key	Yes		No		0		
	2	Reserved					0		
	3	Reserved					0		
	4	Reserved					0		
	5	Reserved					0		
	6	Reserved					0		
	7	Reserved					0		
	8	Reserved					0		

## • Soft switch function description

### SW-A1 No. 1 Protect from echo

Used to protect from echo in reception.

### SW-A1 No. 2 Forced 4800BPS reception

When line conditions warrant that receptions take place at 4800 BPS repeatedly.

It may improve the success of receptions by setting at 4800BPS.

This improves the receiving document quality and reduces handshake time due to fallback during training.

### SW-A1 No. 3 Footer print

When set to "1", the date of reception, the sender machine No., and the page No. are automatically recorded at the end of reception.

### SW-A1 No. 4 Length limitation of copy/send/receive

Used to set the maximum page length.

To avoid possible paper jam, the page length is normally limited to 0.6 meter for copy or transmit, and 1.5 meters for receive.

It is possible to set it to "No limit" to transmit a long document, such as a computer print form, etc. (In this case, the receiver must also be set to no limit.)

### SW-A1 No. 5 CSI transmission

(CSI TRANSMISSION) is a switch to set whether the machine sends or does not send the signal (CSI signal) informing its own telephone No. to the remote fax machine when information is received. When "nonsending" is set, the telephone No. is not output on the remote transmitting machine if the remote transmitting machine has the function to display or print the telephone No. of receiving machine, using this CSI signal.

### SW-A1 No. 6 DIS receive acknowledgment during G3 transmission

Used to make a choice of whether reception of DIS(NSF) is acknowledged after receiving two DISs(NSFs) or receiving one DIS (two NSF). It may be useful for overseas communication to avoid an echo suppression problem, if set to 1.

### SW-A1 No. 7 Non modulated carrier for V29 transmission mode

Though transmission of a nonmodulated carrier is not required for transmission by the V29 modem according to the CCITT Recommendation, it may be permitted to a send nonmodulated carrier before the image signal to avoid an echo suppression problem.

It may be useful for overseas communication to avoid an echo suppression problem, if set to 1.

### SW-A1 No. 8 Reserved

Set to "1".

### SW-A2 No. 1 ~ No. 4 Modem speed

Used to set the initial modem speed. The default is 9600BPS.

It may be necessary to program it to a slower speed when frequent line fallback is encountered, in order to save the time required for fallback procedure.

### SW-A2 No. 5 Reserved

Set to "1".

### SW-A2 No. 6 H2 mode

Used to determine reception of H2 mode (15 sec transmission mode).

When set to OFF, H2 mode reception is inhibited even though the transmitting machine has H2 mode function.

### SW-A2 No. 7 Communication error treatment in RTN sending mode (Reception)

Used to determine communication error treatment when RTN is sent by occurrence of a received image error in G3 reception. When it is set to "1", communication error is judged as no error.

### SW-A2 No. 8 CNG transmission

When set to "0", this model allows CNG transmission by pressing the Start key in the key pad dialing mode. When set to "1", CNG transmission in the key pad dialing mode cannot be performed. In either case, CNG transmission can be performed in the auto dial mode.

### SW-A3 No. 1, No. 2 CED tone signal interval

For international communication, the 2100Hz CED tone may act as an echo suppression switch, causing a communication problem.

Though SW-A3 No. 1 and No. 2 are normally set to 0, this setting is used to change the time between the CED tone signal to eliminate the communication caused by echo.

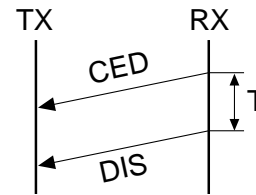

### SW-A3 No. 3 MR coding

Used to select the MR coding enable or disable.

### SW-A3 No. 4 ~ No. 8 Reserved

Set to "0".

### SW-A4 No. 1 ~ No. 5 Signal transmission level (0~-31 dBm setting by 1dBm step)

Used to control the signal transmission level in the range of -0dB to -31dB.

The factory setting is at -10dB (MODEM output).

### SW-A4 No. 6 Protocol monitor (Error Print)

If set to "1", protocol is printed at communication error.

### SW-A4 No. 7 Protocol monitor

Normally set to "0". If set to "1", communication can be checked, in case of trouble, without using a G3 tester or other tools.

When communication FSK data transmission or reception is made, the data is taken into the buffer. When communication is finished, the data is analyzed and printed out. When data is received with the line monitor (SW4-No. 8) set to "1" the reception level is also printed out.

### SW-A4 No. 8 Line monitor

Normally set to "0". If set to "1", the transmission speed and the reception level are displayed on the LCD. Used for line tests.

### SW-A5 No. 1, No. 2 Digital equalization setting (Reception)

Line equalization when reception is to be set according to the line characteristics.

Setting should be made according to distance between the telephone and the telephone company central switching station.

### SW-A5 No. 3, No. 4 Digital equalization setting (Transmitter)

Line equalization when transmission is to be set according to the line characteristics.

Setting should be made according to distance between the telephone and the telephone company central switching station.

**SW-A5 No. 5, No. 6 Digital equalization setting (Reception for Caller ID)**

Line equalization when reception for CALLER ID is to be set according to the line characteristics.  
Setting should be made according to distance between the telephone and the telephone company central switching station.

**SW-A5 No. 7 Error criterion**

Used to select error criterion for sending back RTN when receiving image data.

**SW-A5 No. 8 Anti junk fax check**

When using the Anti junk fax function, set to "1".

**SW-A6 No. 1 Auto gain control(MODEM)**

When this mode is enabled, if the reception signal level is under 31dBm, the modem itself controls the signal gain automatically.

**SW-A6 No. 2 End buzzer**

Setting this bit to 0 will disable the end buzzer (including the error buzzer/on-hook buzzer).

**SW-A6 No. 3 Disconnect the line when DIS is received in RX mode**

Bit1 = 0 : When DIS signal is received during RX mode, disconnect the line immediately.  
Bit1 = 1 : When DIS signal is received during RX mode, wait for the next signal.

**SW-A6 No. 4 Equalizer freeze control (MODEM)**

This switch is used to perform reception operation by fixing the equalizer control of modem for the line which is always in unfavorable state and picture cannot be received.  
\* Usually, the control is executed according to the state of line where the equalizer setting is changed always.

**SW-A6 No.5 Equalizer freeze 7200BPS only**

Setting which specifies SW-A6 No. 4 control only in condition of 7200BPS modem speed.

**SW-A6 No. 6 CNG transmission in manual TX mode**

When set to "1", fax transmit the CNG signal in case of manual transmission mode (User press the START key after waiting for the fax answering signal from handset or speaker).

**SW-A6 No. 7 Initial compression scheme for sharp fax in TX mode**

When set to "0", if the other fax is Sharp model, fax transmit the document by H2 mode.  
When set to "1", even if the other fax is Sharp model, fax transmit the document by MR mode.

**SW-A6 No. 8 Modem speed automatic down when RX level is under -40dBm**

When set to "1", if fax signal level is under -40dBm during reception, machine selects the slower modem speed automatically.  
It is effective when noises occur on the received document due to the long distance communications.

**SW-A7 No. 1, No. 2 EOL (End Of Line) detect timer**

Used to make a choice of whether to use the 5 or 13 or 20 or 25 seconds timer for detection of EOL.  
This is effective to override communication failures with some facsimile models that have longer EOL detection.

**SW-A7 No. 3 ~ No. 8 Reserved**

Set to "0".

**SW-B1 No. 1 Hold key**

Used to set YES/NO of holding function by the HOLD key.

**SW-B1 No. 2 Auto dial fax transmission by REDIAL key**

When set to "1", if original documents are set to the feeder and you press REDIAL key, machine will dial and transmit the documents automatically.  
When set to "0", operator needs to press the START key after FAX reception tone is heard.

**SW-B1 No. 3 Reserved**

Set to "0".

**SW-B1 No. 4 ~ No. 8 Recall interval (0~15.5min setting by 0.5min step)**

Choice is made for a redial interval for speed and rapid dial calls.  
Use a binary number to program this with 0.5min steps. If set to 0 accidentally, 0.5min will be assumed.

**SW-B2 No. 1 ~ No.4 Recall times (0~15times setting)**

Choice is made as to how many redials there should be.

**SW-B2 No. 5 Dial tone detection (Before auto dial)**

Used to set YES/NO of dial tone detection in auto dialing.

**SW-B2 No. 6 Reserved**

Set to "0".

**SW-B2 No. 7 Busy tone detection (After auto dial)**

Used to set YES/NO of busy tone detection after auto dialing.

**SW-B2 No. 8 Busy tone detection pulse number (After auto dial)**

Used for detection of busy tone in 2 or 4 pulses.

**SW-B3 No. 1, No. 2 Waiting time after dialing**

This is waiting time for the opponent's signals after dialing.  
45 / 55 / 90 / 140 seconds settings are available.

**SW-B3 No. 3 ~ No. 8 Reserved**

Set to "0".

**SW-B4 No. 1 Dialing pause (sec/pause)**

Pauses can be inserted between telephone numbers of direct dial connection. Selection of 4 sec or 2 sec pause is available.

**SW-B4 No. 2 Dial mode**

When using the pulse dial, set to 0. When using the tone dial, set to 1.

**SW-B4 No. 3 Pulse → Tone change function by ✕ key**

When setting to 1, the mode is changed by pressing the ✕ key from the pulse dial mode to the tone dial mode.

**SW-B4 No. 4 Dial pulse make/break ratio (%)**

When using the 33% make ratio pulse dial, set to 0.  
When using the 40% make ratio pulse dial, set to 1.

**SW-B4 No. 5, No. 6 Auto dial mode Delay timer of before line connect**

Delay time between the dial key input and line connection under the auto dial mode.

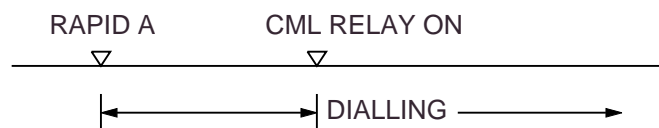

No.5=0 No.6=0 : 0sec  
No.5=0 No.6=1 : 1.5sec  
No.5=1 No.6=0 : 3.0sec  
No.5=1 No.6=1 : 4.5sec

**SW-B4 No. 7, No. 8 Reserved**

Set to "0".

**SW-B5 No. 1 ~ No. 3 Auto dial mode Delay timer of after line connect**

Delay time between the line connection and dial data output under the auto dial mode.  
This setting is available when dial tone detection(SW-B2 No. 5) is set to "NO".



No. 1	No. 2	No. 3	
0	0	0	1.7sec
0	0	1	2.0sec
0	1	0	2.5sec
0	1	1	3.0sec
1	0	0	3.6sec
1	0	1	4.0sec
1	1	0	5.5sec
1	1	1	7.0sec

**SW-B5 No. 4 Fax signal detection after telephone mode dial**

When set to "1", if machine detects the fax answering signal after telephone calling (handset off-hook or speaker mode dial), machine starts to receive the documents automatically.

**SW-B5 No. 5 Recalling fixed only one time when dialing was unsuccessful without detecting busy tone signal**

When set to "1", if machine does not detect the busy tone after auto dialing and dialing is unsuccessful, machine will try to recall only one time.

**SW-B5 No. 6 ~ No. 8 Reserved**

Set to "0".

**SW-B6 No. 1 ~ No. 5 DTMF signal transmission level (Low frequency 0~15.5dBm setting by 0.5dBm step)**

The transmission level of DTMF signal is adjusted. (lower frequency)

00000: 0dBm

↓

11111: -15.5 dBm (-0.5dBm x 31)

**SW-B6 No. 6 ~ No. 8 Reserved**

Set to "0".

**SW-B7 No. 1 ~ No. 5 DTMF signal transmission level (High frequency 0~15.5dBm setting by 0.5dBm step)**

The transmission level of DTMF signal is adjusted. (higher frequency)

00000: 0dBm

↓

11111: -15.5 dBm (-0.5dBm x 31)

**SW-B7 No. 6 ~ No. 8 Reserved**

Set to "0".

**SW-C1 No. 1, No. 2 Reading slice (Binary)**

Used to determine the set value of reading density in standard/fine/super-fine mode.

The standard setting is "00"(Factory setting is "00").

**SW-C1 No. 3, No. 4 Reading slice (Half tone)**

Used to determine the set value of reading density in half tone mode.  
The standard setting is "00"(Factory setting is "00").

**SW-C1 No. 5 Line density selection**

Used to set the transmission mode which is automatically selected when the Resolution key is not pressed. In the copy mode, however, the fine mode is automatically selected unless the Resolution key is manually set to another mode.

**SW-C1 No. 6 Reserved**

Set to "0".

**SW-C1 No. 7 MTF correction in half tone mode**

This allows selection of MTF correction (dimness correction) in the half tone mode.

When "NO" (=1) is selected, the whole image becomes soft and mild. Clearness of characters will be reduced. Normally set to "YES" (=0).

**SW-C1 No. 8 Reserved**

Set to "0".

**SW-D1 No.1 ~ No. 4 Number of rings for auto receive (0~15rings setting)**

When the machine is set in the auto receive mode, the number of rings before answering can be selected. It may be set from one to nine rings using a binary number. Since the facsimile telephone could be used as an ordinary telephone if the handset is taken off the hook, it should be programmed to the user's choice. If the soft switch was set to 1, direct connection is made to the facsimile.

If a facsimile calling beep was heard when the handset is taken off the hook, press the START key and put the handset on the hook to have the facsimile start receiving. If it was set to 0 accidentally, receive ring is set to 1.

NOTE: If the machine is set to answer after a large number of rings, it may not be able to receive faxes successfully.

If you have difficulty receiving faxes, reduce the number of rings to a maximum of 5.

**SW-D1 No. 5 Automatic switching manual to auto receive function**

This soft switch is used to select whether the machine should switch to the auto receive mode after 5 rings in the manual receive mode or remain in the same way as SW-D1 No. 1, No. 2, No. 3 and No. 4 "0"1"0"1"(5 rings).

**SW-D1 No. 6, No. 7 Cl detect frequency**

Detection frequency of ring signal for auto reception is set.

When set to No. 6=0, No. 7=0, frequency is set to PTT recommendation.

When set to No. 6=0, No. 7=1, frequency is set to 11.5Hz or more.

When set to No. 6=1, No. 7=0, frequency is set to 13.0Hz or more.

When set to No. 6=1, No. 7=1, frequency is set to 20.0Hz or more.

**SW-D1 No. 8 Reserved**

Set to "0".

**SW-D2 No. 1 ~ No. 3 Distinctive ringing setting**

When the ringing setting is turned off, all of the CI signals are received.  
When any of the standard, and ring patterns 1 through 3 is selected for the ringing setting, only the selected CI signal is received.

**CI signal patterns**

The CI signal patterns consists of the standard pattern, and ring patterns 1 through 7. The standard pattern is the conventional one.

STANDARD	
RING PATTERN 1 for USA	
RING PATTERN 2 for USA	
RING PATTERN 3 for USA	
RING PATTERN 1 for CANADA	
RING PATTERN 2 for CANADA	
RING PATTERN 3 for CANADA	

**SW-D2 No. 4, No. 5 Reserved**

Set to "0".

**SW-D2 No. 6 Caller ID Function**

Used for Caller ID function.

**SW-D2 No. 7, No. 8 Reserved**

Set to "0".

**SW-D3 No. 1 ~ No. 5 CI off detection timer (0~1550ms setting by 50ms step)**

Set the minimum time period of CI signal interruption which affords to be judged as a CI OFF section with 50ms steps.  
(Example)

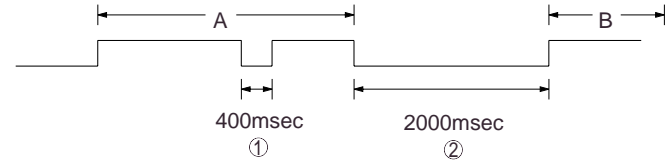

0 1 1 1 0 (50ms~14) : 700ms(CI interruption>700ms:Judged as a CI OFF section)

The section 1 is not judged as a CI OFF section, the CI signal A is counted as one signal. The section 2 is judged as a CI OFF section, the CI signal B is considered as the second signal.

0 0 1 1 1 (50ms~7) : 350ms(CI interruption>350ms:Judged as a CI OFF section)

The section 1 is judged as a CI OFF section, and the CI signal A is counted as two signals. The section 2 is judged as a CI OFF section, and the CI signal B is considered as the third signal.

**SW-D3 No. 6 ~ No. 8 Reserved**

Set to "0".

**SW-D4 No. 1 ~ No. 6 DTMF type Caller ID RX level (0~44dBm setting by 1dBm step)**

This is used for DTMF type Caller ID detection level setting.

**SW-D4 No. 7, No. 8 Reserved**

Set to "0".

**SW-E1 No. 1 ~ No. 8 Reserved**

Set to "0".

**SW-E2 No. 1 ~ No. 8 Reserved**

Set to "0".

**SW-E3 No. 1 ~ No. 8 Reserved**

Set to "0".

**SW-F1 No. 1, No. 2 DTMF detection time**

Used to set detect time of DTMF (Dual Tone Multi Frequency) used in remote reception(5××).

The longer the detect time is, the less the error detection is caused by noises.

**SW-F1 No. 3 Protection of remote reception (5××) detection**

Used to set the function of remote reception (5××). When set to "1", the remote reception function is disabled.

**SW-F1 No. 4 Remote reception with GE telephone**

"1": Compatible with TEL mode by GE

"0": Not compatible

- When sending (5××) for remote reception with a GE manufactured telephone remote reception may not take place because of special specifications in their DTMF.

To overcome this, a soft SW is provided to change the modem setting to allow for remote reception.

- If this soft SW is set to "1", other telephone sets may be adversely affected.

**SW-F1 No. 5 ~ No. 8 Remote operation code figure by external TEL (0~9)**

Remote operation codes can be changed from 0 through 9. If set to greater than 9, it defaults to 9. The "5××" is not changed.

Ex- 7×× (Default : 5××)

**SW-F2 No. 1 CNG detection in STAND-BY mode**

When setting to "1", the CNG signal detection function during standby stops.

**SW-F2 No. 2, No. 3 Number of CNG detect (AM mode)**

Used for detection of CNG in 1 to 4 pulses.

**SW-F2 No. 4, No. 5 Number of CNG detect (STAND-BY mode)**

Used for detection of CNG in 1 to 4 pulses.

**SW-F2 No. 6 ~ No. 8 Reserved**

Set to "0"

**SW-G1 No. 1 ~ No. 8 Reserved**

Set to "0"

**SW-G2 No. 1 ~ No. 8 Reserved**

Set to "0"

**SW-G3 No. 1 ~ No. 8 Reserved**

Set to "0".

**SW-G4 No. 1 ~ No. 8 Reserved**

Set to "0".

**SW-H1 No. 1 ~ No. 8 Reserved**

Set to "0".

**SW-H2 No. 1 ~ No. 8 Reserved**

Set to "0".

**SW-I1 No. 1 ~ No. 8 Reserved**

Set to "0".

**SW-I2 No. 1 ~ No. 8 Reserved**

Set to "0".

**SW-I3 No. 1 ~ No. 8 Reserved**

Set to "0".

**SW-I4 No. 1 ~ No. 8 Reserved**

Set to "0".

**SW-I5 No. 1 ~ No. 8 Reserved**

Set to "0".

**SW-I6 No. 1 ~ No. 8 Reserved**

Set to "0".

**SW-I7 No. 1 ~ No. 8 Reserved**

Set to "0".

**SW-I8 No. 1 ~ No. 8 Reserved**

Set to "0".

**SW-J1 No. 1 Sender's phone number setting**

Used to make a choice of whether the registered sender's phone number can be changed or not. If the switch is set to "1", new registration of the sender's phone number is disabled to prevent accidental wrong input.

**SW-J1 No. 2 Summer time setting (Daylight saving)**

Used to set YES/NO of automatic clock adjustment for Summer time(Daylight saving time).

**SW-J1 No. 3, No. 4 Ringer Volume**

Used to adjust ringing volume.

**SW-J1 No. 5, No. 6 Speaker Volume**

Used to adjust sound volume from a speaker.

**SW-J1 No. 7, No. 8 Reserved**

Set to "0".

**SW-J2 No. 1, No. 2 Handset receiver volume**

Used to adjust sound volume from a handset receiver volume.

**SW-J2 No. 3 ~ No. 8 Reserved**

Set to "0".

**SW-J3 No. 1 ~ No. 3 Communication results printout (Transaction report)**

It is possible to obtain transaction results after each communication. Normally, the switch is set (No. 1 : 0, No. 2 : 0, No. 3 : 0) so that the transaction report is produced only when a communication error is encountered.

If No.1 was set to 0 and No. 2 to 1 and No. 3 to 0, the transaction report will be produced every time a communication is done, even if the communication was successful.

Setting No. 1 to 0 and No. 2 to 1 and No. 3 to 1 will disable this function. No transaction report printed.

**SW-J3 No. 4 Time format**

When set to "0", 24hour time format is used.

When set to "1", 12hour time format is used.

**SW-J3 No. 5 Date format**

When set to "0", Day-Month-Year format is used.

When set to "1", Month-Day-Year format is used.

**SW-J3 No. 6 ~ No. 8 Reserved**

Set to "0".

**SW-K1 No. 1 Entering diag mode by pressing SPEED key**

A bit which is used in the production process only. When the SPEED key is pressed, the switch is changed from the stand-by state to the diag mode.

**SW-K1 No. 2 ~ No. 8 Reserved**

Set to "0".

### [3] Troubleshooting

Refer to the following actions to troubleshoot any of the problems mentioned in 1-4.

[1] A communication error occurs.

[2] Image distortion produced.

[3] Unable to do overseas communication.

[4] Communication speed slow due to FALLBACK.

- Increase the transmission level SOFT SWITCH A4-1, 2, 3, 4, 5. May be used in case [1] [2] [3].

- Decrease the transmission level SOFT SWITCH A4-1, 2, 3, 4, 5. May be used in case [3].

- Apply line equalization SOFT SWITCH A5-1, 2. May be used in case [1] [2] [3] [4].

- Slow down the transmission speed SOFT SWITCH A2-1, 2, 3, 4. May be used in case [2] [3].

- Replace the TEL/LIU PWB. May be used in all cases.

- Replace the control PWB. May be used in all cases.

\* If transmission problems still exist on the machine, use the following format and check the related matters.

TO: \_\_\_\_\_ ATT: \_\_\_\_\_ Ref.No.: \_\_\_\_\_  
 CC: \_\_\_\_\_ ATT: \_\_\_\_\_ Date: \_\_\_\_\_  
 FM: \_\_\_\_\_ Dept: \_\_\_\_\_  
 \_\_\_\_\_ Sign: \_\_\_\_\_

***** Facsimile communication problem *****				Ref.No.:								
From: Mr. _____		Fax Tel No.: _____		Date: _____								
Our customer	Name _____		Tel No. _____									
	Address _____		Fax No. _____									
	Contact person _____		Model name _____									
Other party	Name _____		Tel No. _____									
	Address _____		Fax No. _____									
	Contact person _____		Model name _____									
Problem mode	Line: Domestic / international _____		Model: G3	Phase: A, B, C, D.								
	Reception / Transmission	Automatic reception / Manual reception _____										
		Automatic dialing / Manual dialing / Others _____										
Frequency: _____	%		ROM version: _____									
Confirmation item			Please mark problem with an X. No problem is: 0.									
			A1	A2	B1	B2	C1	C2	D1	D2	E1	E2
			Transmission level setting is ( ) dB at our customer									
			Transmission level ( ) dBm			Reception level ( ) dBm						
			By level meter at B1 and B2									
Comment												
Countermeasure												
**** Please attach the G3 data and activity report on problem. ****												

\* Please complete this report before calling the "TAC" hotline if problem still occurs.

**[4] Error code table****1. Communication error code table****G3 Transmission**

Code	Final received signal	Error Condition (Receiver side)
0	Incomplete signal frame	Cannot recognize bit stream after flag
1	NSF, DIS	Cannot recognize DCS signal by echo etc. Cannot recognize NSS signal (FIF code etc)
2	CFR	Disconnects line during reception (carrier missing etc)
3	FTT	Disconnects line by fall back
4	MCF	Disconnects line during reception of multi page Cannot recognize NSS, DCS signal in the case of mode change
5	PIP or PIN	The line is hung up without replying to telephone request from the receiving party.
6	RTN or RTP	Cannot recognize NSS, DCS signal after transmit RTN or RTP signal.
7	No signal or DCN	No response in receiver side or DCN signal received* (transmitter side)
8	–	Owing to error in some page the error could not be corrected although the specified number of error retransmissions were attempted.
11	–	Error occurred after or while reception by the remote (receiving) machine was revealed to be impossible.
12	–	Error occurred just after fallback.
13	–	Error occurred after a response to retransmission end command was received.

**G3 Reception**

Code	Final received signal	Error Condition (Receiver side)
0	Incomplete signal frame	Cannot recognize bit stream after flag
1	NSS, DCS	Cannot recognize CFR or FTT signal Disconnects line during transmission (line error)
2	NSC, DTC	Cannot recognize NSS signal (FIF code etc)
3	EOP	Cannot recognize MCF, PIP, PIN, RTN, RTP signal
4	EOM	Cannot recognize MCF, PIP, PIN, RTN, RTP signal in the case of mode change
5	MPS	The line is hung up without replying to communication request.
6	PR1-Q	Cannot recognize PIP, PIN signal in the case of TALK request
7	No signal or DCN	No response in transmitter (cannot recognize DIS signal) or DCN signal received* (receiver side)
8	–	Error occurred upon completion of reception of all pages.
9	–	Error occurred when mode was changed or Transmission/Reception switching was performed.
10	–	Error occurred during partial page or physical page reception.
11	–	Error occurred after or during inquiry from the remote (transmitting) machine as to whether reception is possible or not.
12	–	Error occurred during or just after fallback.
13	–	Error occurred after the retransmission end command was received.