

# CHAPTER 4. DIAGRAMS

## [1] Block diagram

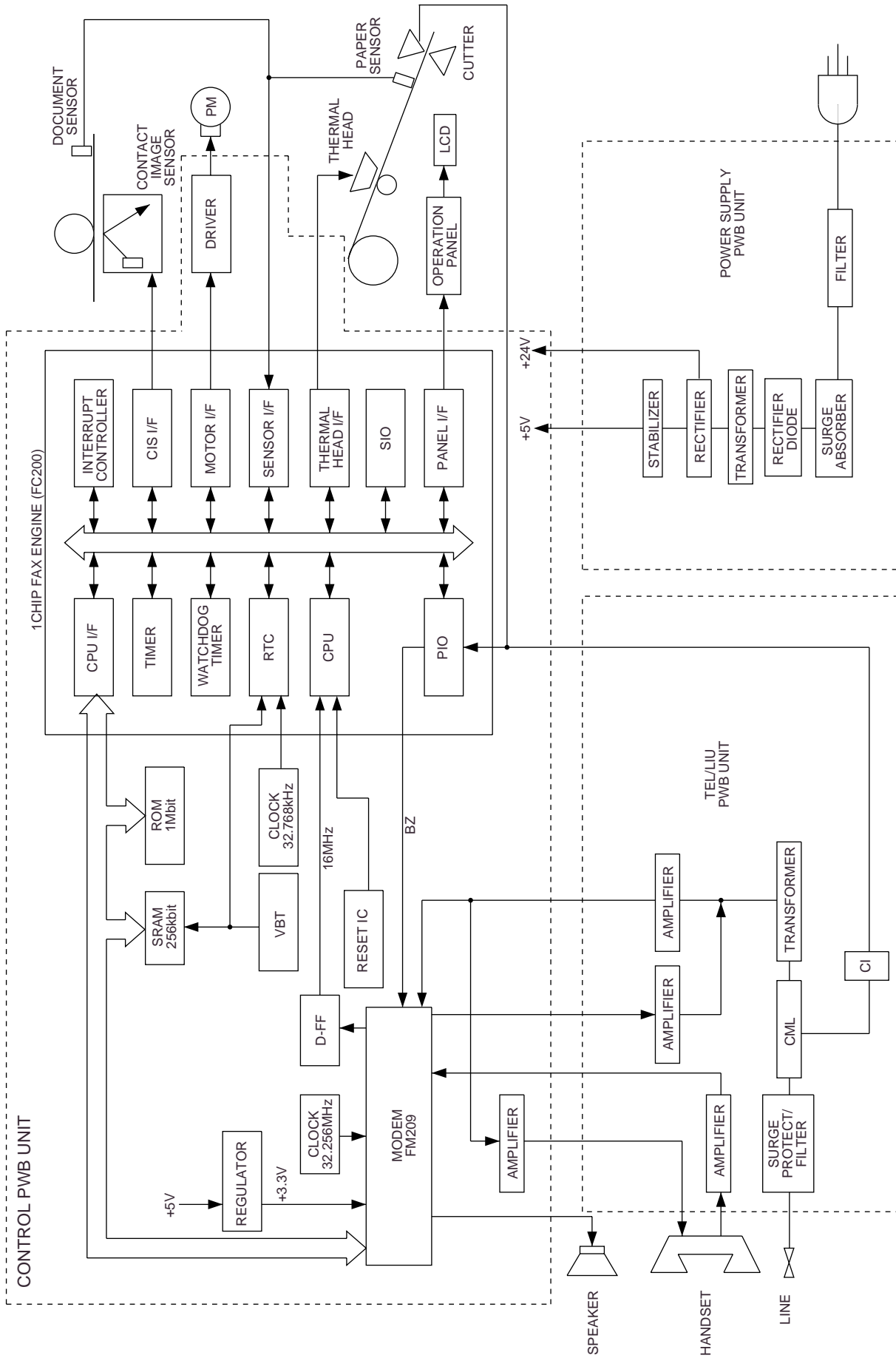

[2] Wiring diagram

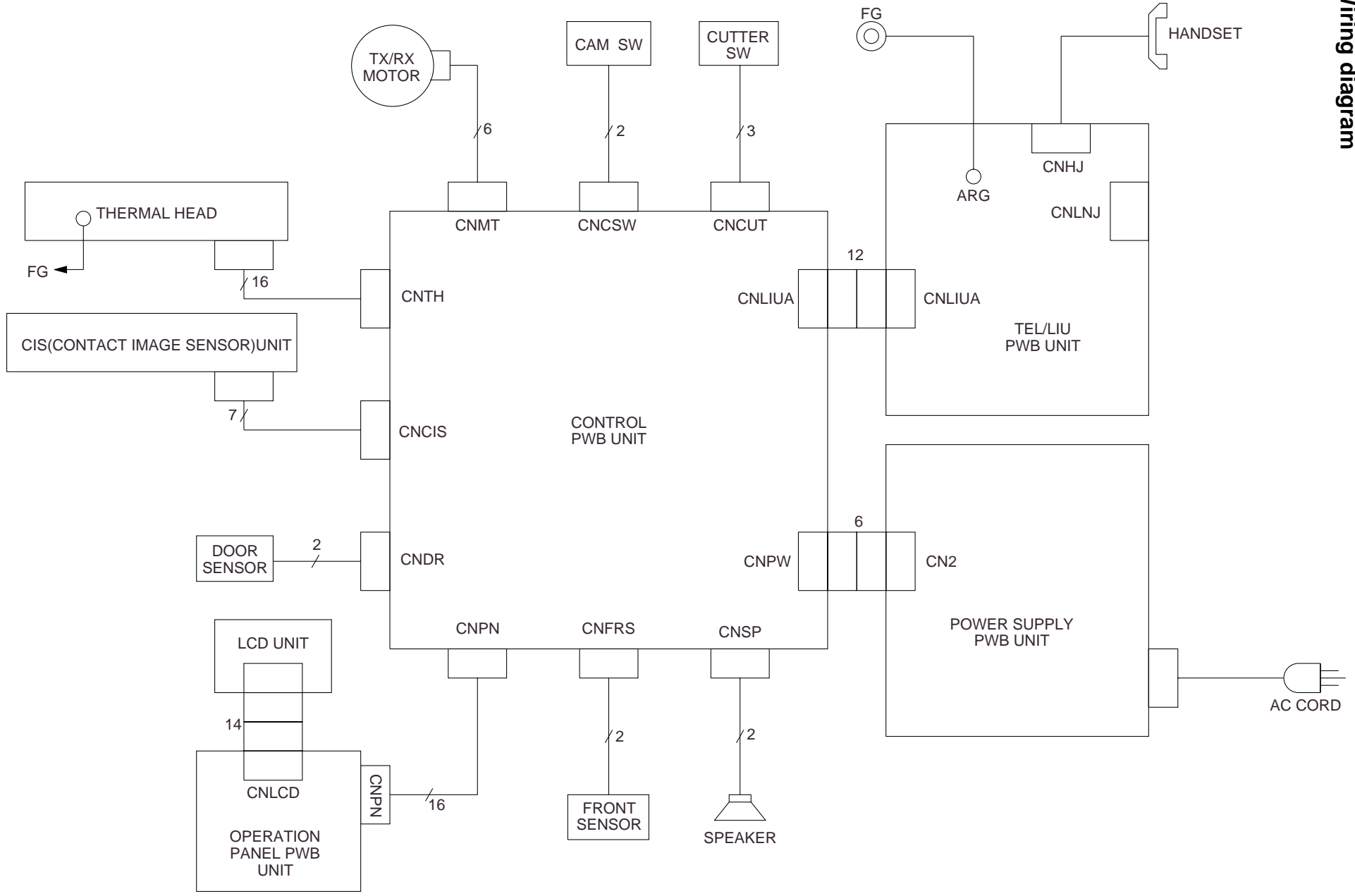

4-2

[3] Point- to-point diagram

