

## General Precautions for Installation/Service/Maintenance for the MD-0101

The installation and service should be done by a qualified service technician.

1. When installing the MD-0101 to the Plain Paper Copier, be sure to follow the instructions described in the "Unpacking/Set-Up Procedure for the MD-0101" booklet which comes with each unit of the MD-0101.
2. The MD-0101 should be installed by an authorized/qualified person.
3. Before starting installation, servicing or maintenance work, be sure to turn off and unplug the copier first.
4. When servicing or maintaining the MD-0101, be careful about the rotating or operation sections such as gear, pulleys, sprockets, cams, belts, etc.
5. When parts are disassembled, reassembly is basically the reverse of disassembly unless otherwise noted in this manual or other related materials. Be careful not to reassemble small parts such as screws, washers, pins, E-rings, toothed washers to the wrong places.
6. Basically, the machine should not be operated with any parts removed or disassembled.
7. Delicate parts for preventing safety hazard problems (such as breakers, thermofuses, fuses, door switches, sensors, etc. if any) should be handled/installed/adjusted correctly.
8. Use suitable measuring instruments and tools.
9. During servicing or maintenance work, be sure to check the serial No. plate and other cautionary labels (if any) to see if they are clean and firmly fixed. If not, take appropriate actions.
10. The PC board must be stored in an anti-electrostatic bag and handled carefully using a wristband, because the ICs on it may be damaged due to static electricity. Before using the wrist band, pull out the power cord plug of the copier and make sure that there is no uninsulated charged objects in the vicinity.
11. For the recovery and disposal of used MD-0101, consumable parts and packing materials, it is recommended that the relevant local regulations/rules should be followed.
12. After completing installation, servicing and maintenance of the MD-0101, return the MD-0101 to its original state, and check operation.

Copyright 2000

TOSHIBA TEC CORPORATION

# CONTENTS

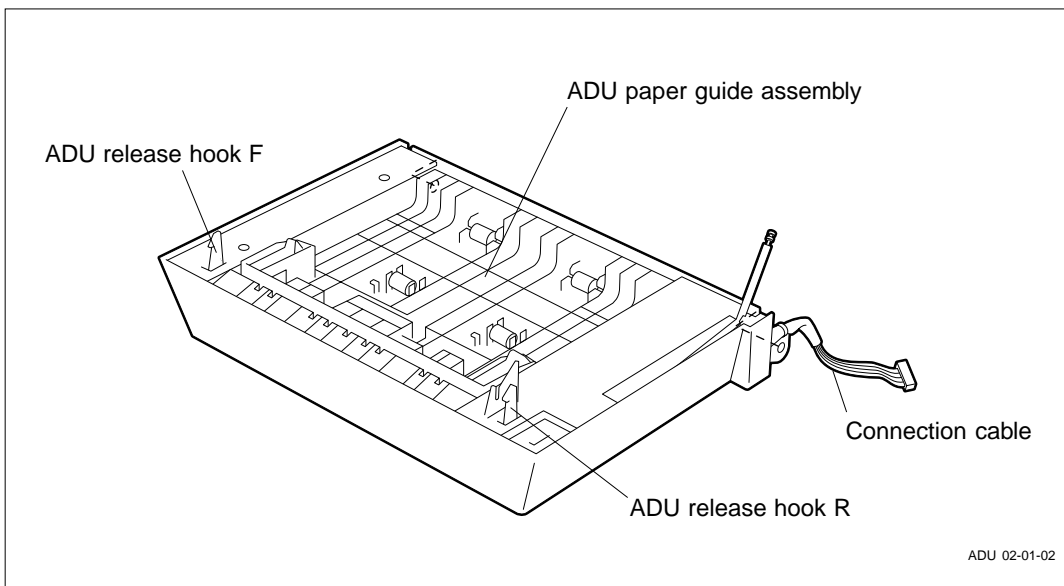
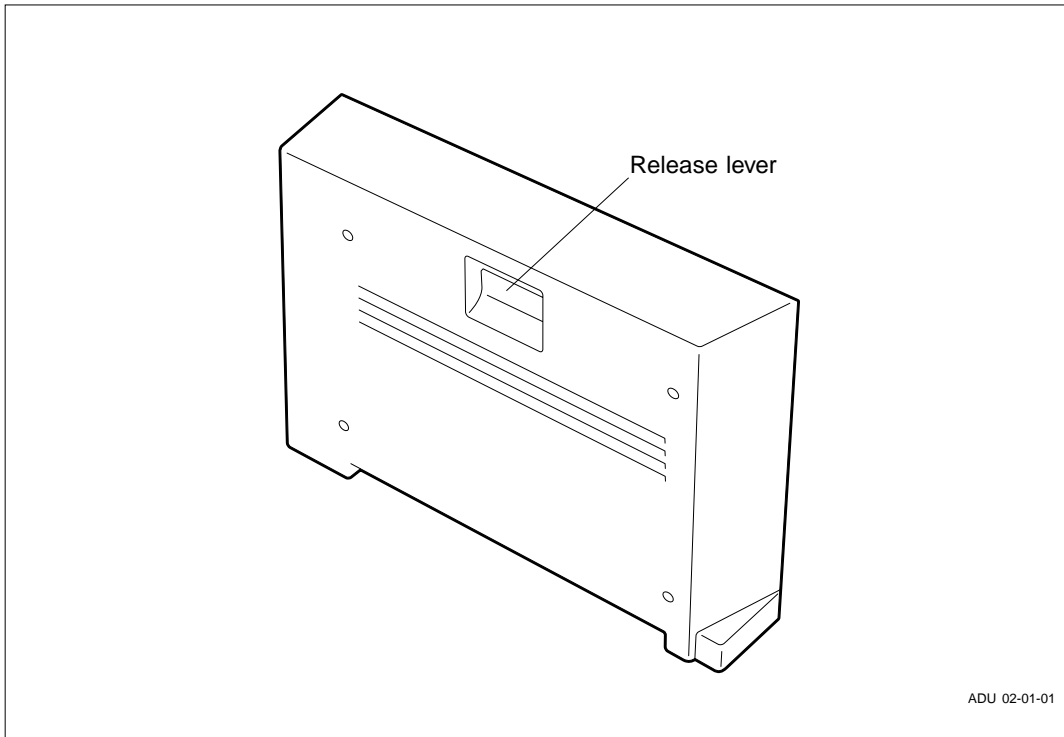
<b>1. SPECIFICATIONS .....</b>	<b>1-1</b>
<b>2. OUTLINE .....</b>	<b>2-1</b>
2.1 Names of Various Components .....	2-1
2.2 Layout of Electrical Parts .....	2-2
2.3 Harness Connection Diagram .....	2-3
2.4 Board Assembly .....	2-4
<b>3. OPERATIONAL DESCRIPTION .....</b>	<b>3-1</b>
3.1 General Operation .....	3-1
3.2 Block Diagram .....	3-1
3.3 Detection of Abnormal Status .....	3-2
3.3.1 Cover open/close detection .....	3-2
3.3.2 Paper jam detection .....	3-2
3.4 Flow Chart .....	3-3
<b>4. MECHANICAL DESCRIPTION .....</b>	<b>4-1</b>
4.1 Paper Feed System .....	4-1
4.2 Drive System .....	4-2
<b>5. CIRCUIT DESCRIPTION .....</b>	<b>5-1</b>
5.1 PWA Block Diagram .....	5-1
5.2 Meaning of Signals .....	5-2
5.3 Timing Chart .....	5-3
<b>6. DISASSEMBLY AND REPLACEMENT .....</b>	<b>6-1</b>

# 1. SPECIFICATIONS

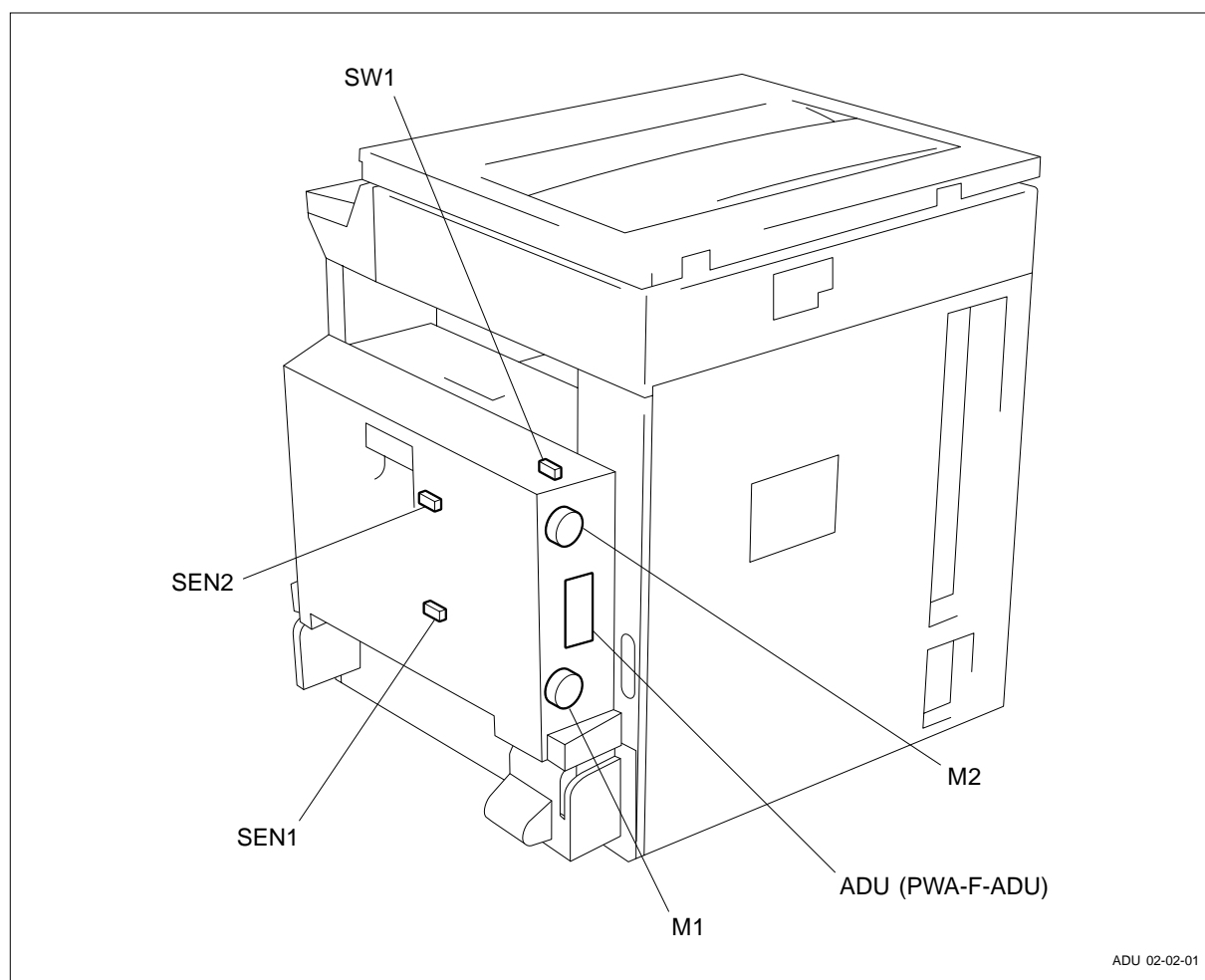
Function	: Stackless unit for duplex printing
Paper	: Size       A3 to A5-R/LD to ST-R : Thickness Normal paper 64 to 80g/m <sup>2</sup> (17 to 21 lbs)
Transport speed	: 92 mm/sec. (DP1600 series) : 124 mm/sec. (DP2000/2500 series)
Dimensions	: 101 (W) x 488 (D) x 345 (H) mm
Weight	: Approx. 4.3 kg
Power supply	: 5VDC, 24VDC (Supplied from copier)

## 2. OUTLINE

### 2.1 Names of Various Components



## 2.2 Layout of Electrical Parts

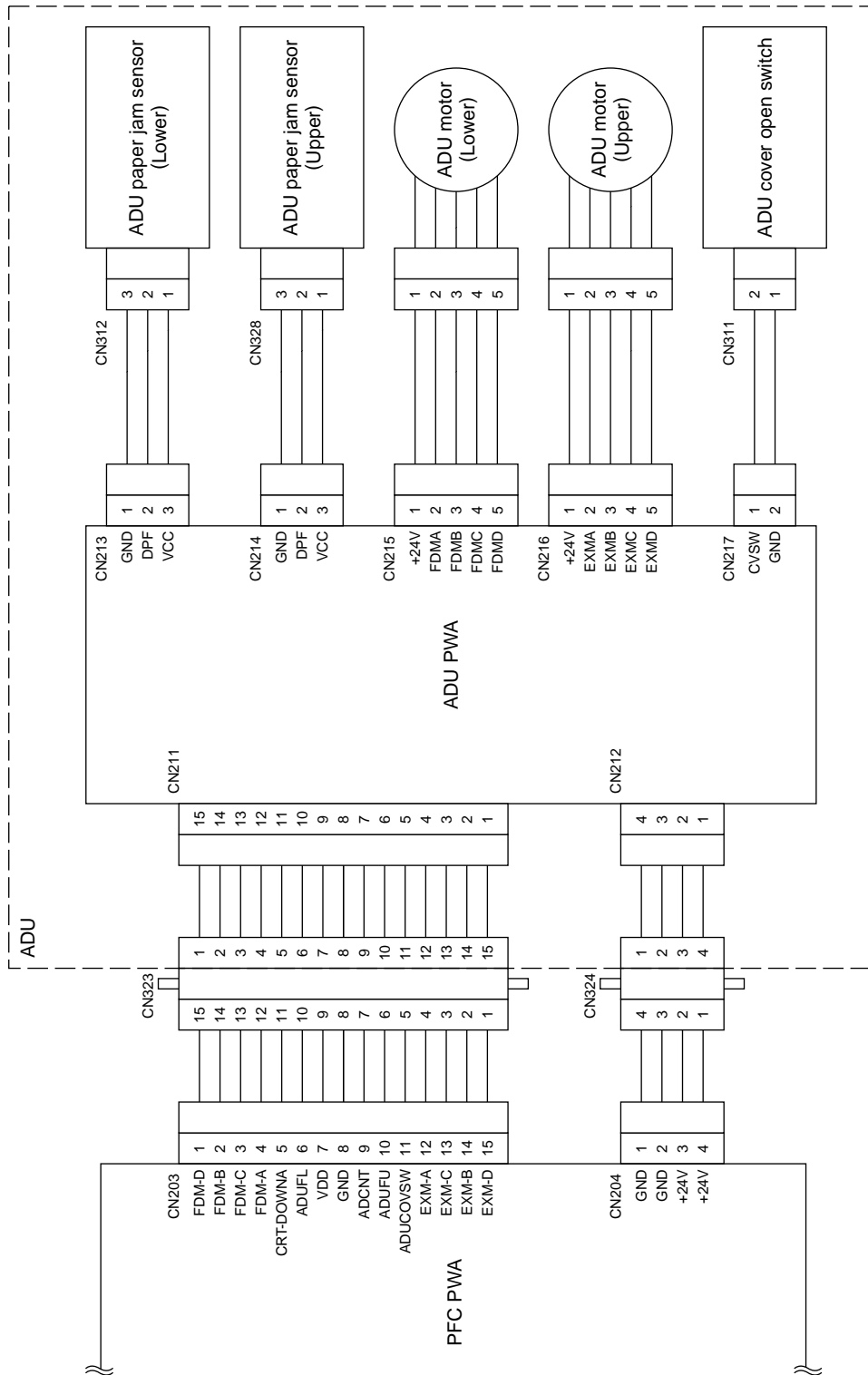


ADU 02-02-01

### Symbols and functions of various devices

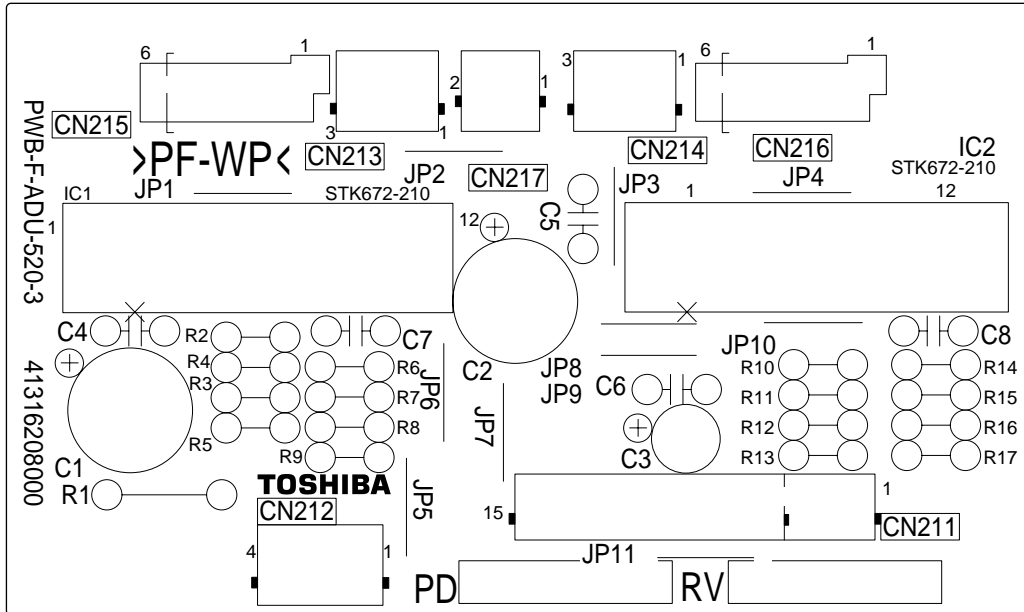
Symbol	Name	Function
SEN1	FED1-SEN ADU paper jam sensor (Lower)	Detects the transport of paper (Lower).
SEN2	FED2-SEN ADU paper jam sensor (Upper)	Detects the transport of paper (Upper).
SW1	ADUCOV-SW ADU cover open switch	Detection of cover open/close status during jam processing, etc.
M1	FED1-MOT ADU motor (Lower)	Drives the roller to transport paper (Lower).
M2	FED2-MOT ADU motor (Upper)	Drives the roller to transport paper (Upper).
ADU	PWA-F-ADU ADU PWA	PWA which relays the sensor signals and drives the motor.

## 2.3 Harness Connection Diagram



ADU 02-03-01

## 2.4 Board Assembly



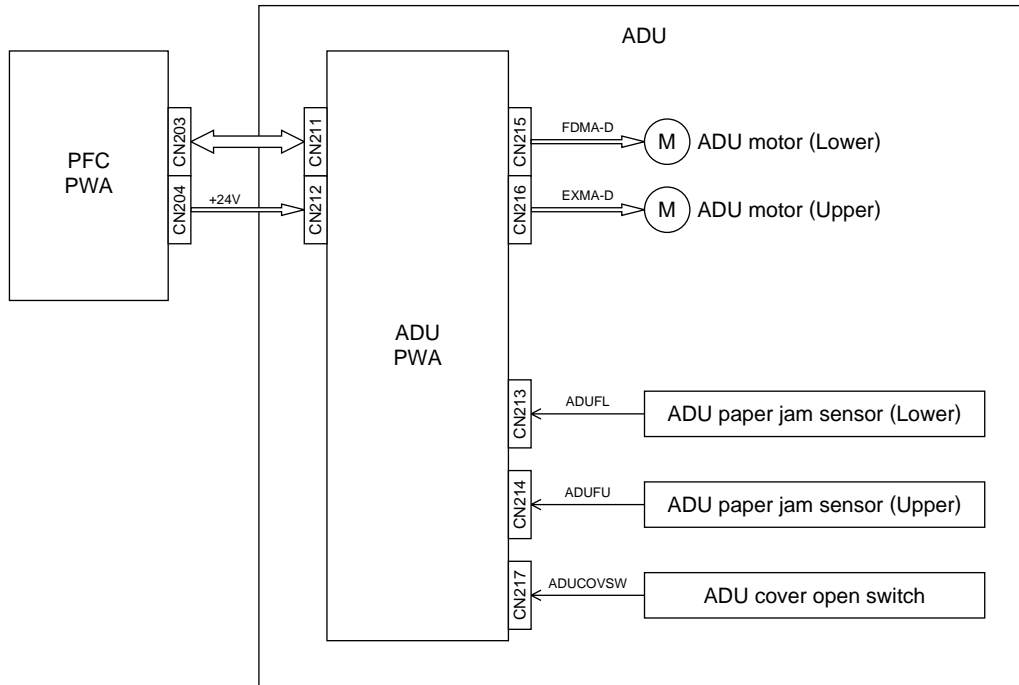
ADU 02-04-01

### 3. OPERATIONAL DESCRIPTION

#### 3.1 General Operation

The ADU is a unit which turns over printed paper. Installation of the unit enables duplex printing on paper. No paper can be stacked in the ADU.

#### 3.2 Block Diagram



ADU 03-02-01

The ADU has three sensors and two motors as shown above. One-side-printed paper passes through the ADU unit to be turned over and returned to the copier. The motor drive circuits (IC1, IC2) only are installed on the ADU PWA.

The motor signals (EXM-A - D, FDM-A - D) are amplified by IC1 and IC2 and drive the motors. The signal of each sensor passes through the ADU PWA and is connected as it is to the PFC PWA.

### **3.3 Detection of Abnormal Status**

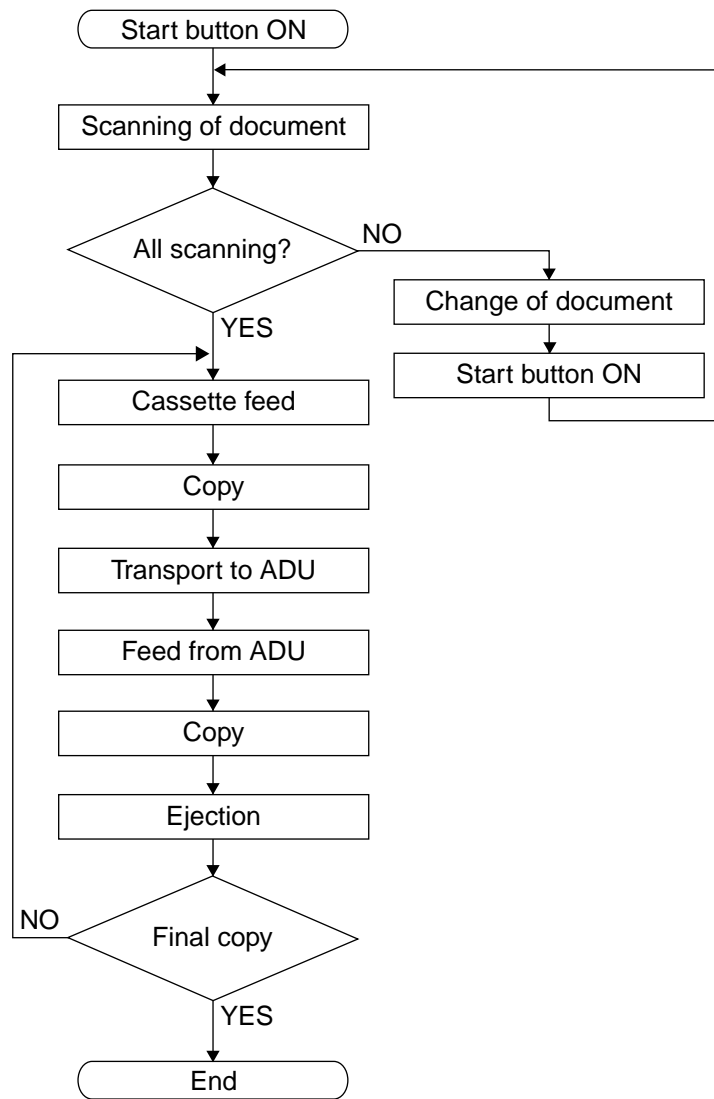
#### **3.3.1 Cover open/close detection**

When the ADU cover open sensor detects the open state of the cover, the detection signal is sent to the copier to stop the transport of paper.

#### **3.3.2 Paper jam detection**

When the one-side-printed paper is loaded into the ADU, the ADU paper jam sensors (upper/lower) turn ON (at "High" level) for a fixed time. If the ADU paper jam sensors (upper/lower) do not turn ON or their ON time is too long, the program will judge it to be paper jamming and stop the operation. The paper jamming can be cleared by opening the ADU and removing the paper.

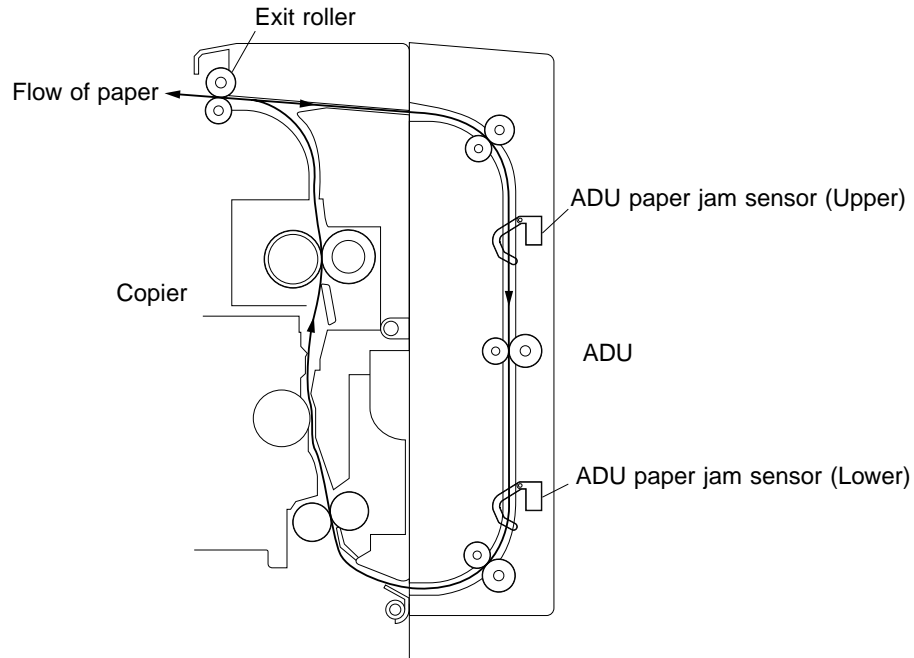
### 3.4 Flow Chart



ADU 03-04-01

## 4. MECHANICAL DESCRIPTION

### 4.1 Paper Feed System



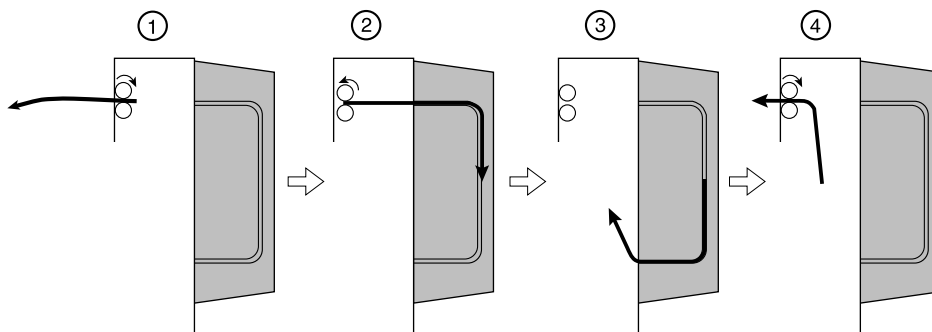
ADU 04-01-01

The ADU has one transport path as shown above and paper enters the ADU from the top and comes out from the bottom. Paper is not stacked in the ADU but the ADU only transports the paper by using the two motors.

#### Flow of Paper

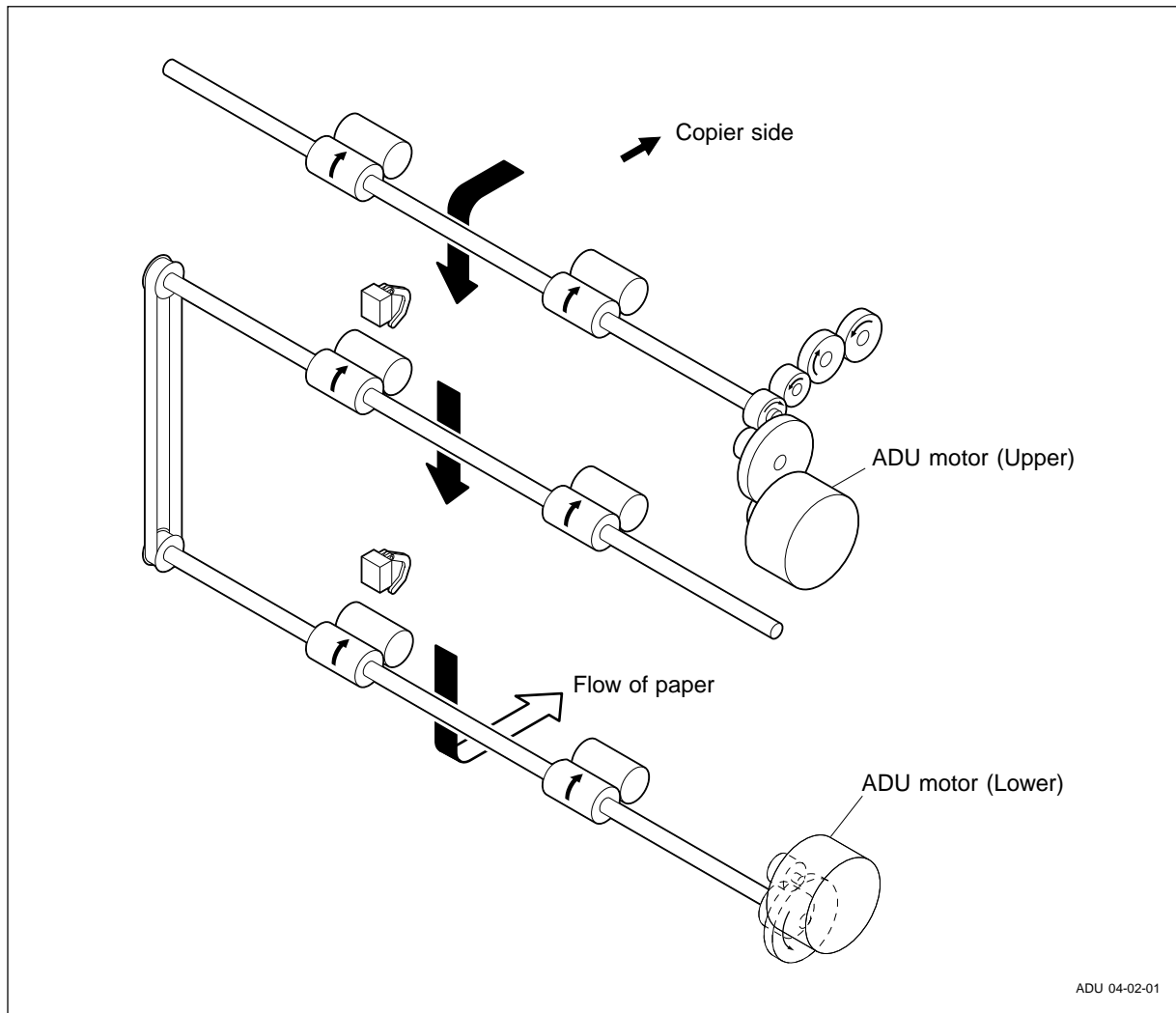
The flow of paper is as follows:

- ① The one-side-printed paper reversed at the exit unit.
- ② The roller in the exit unit reversely turns to draw the paper into the ADU.
- ③ The paper having passed through the ADU is loaded again into the copier from the bottom of the ADU.



ADU 04-04-02

- ④ Printing takes place on the back of the paper and the paper is ejected.



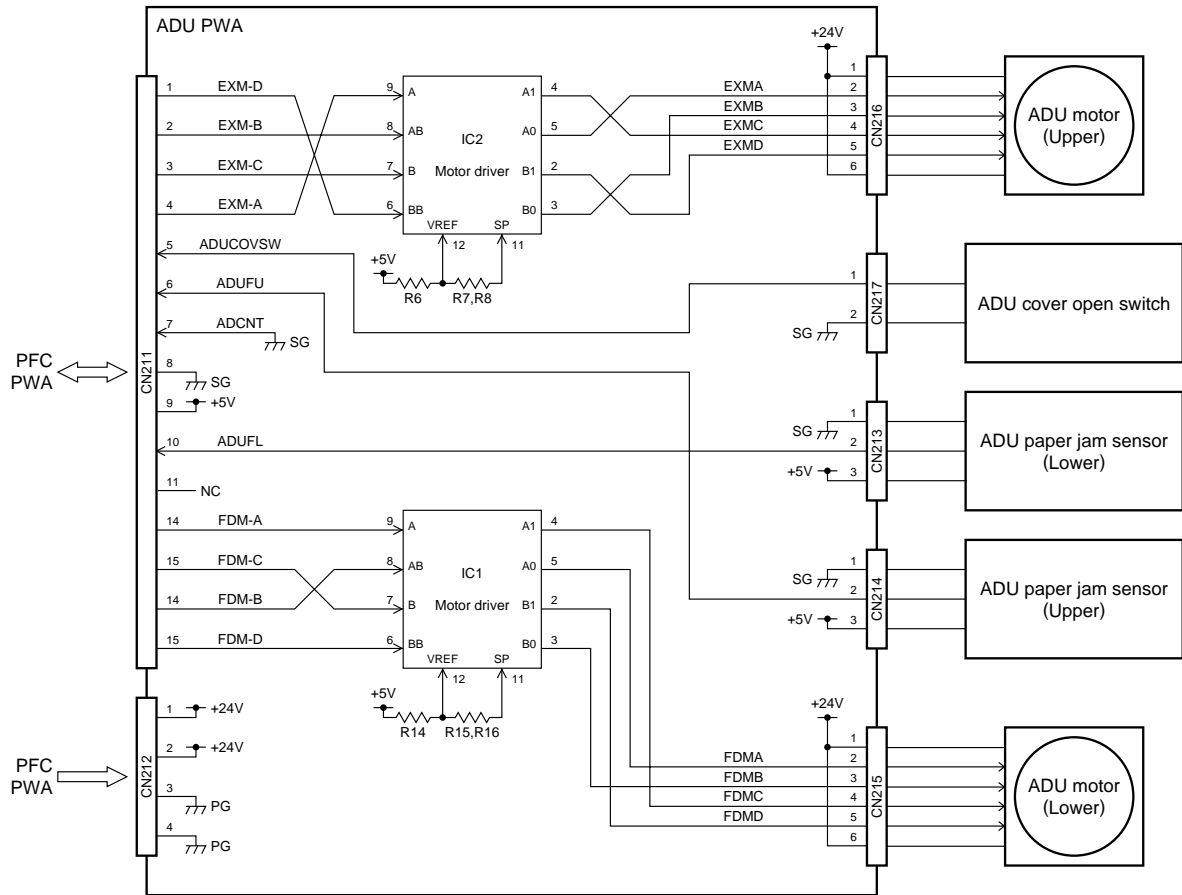
## 4.2 Drive System

In the ADU, paper is transported by two pulse motors. The ADU motor (upper) drives the upper roller and the exit roller of the copier as a result of changing (moving) the gear on the copier side, thereby drawing in the one-side-printed paper from the copier.

The paper drawn into the ADU is fed into the copier again from the ADU (bottom) by the roller driven by the ADU motor (lower). The central roller is driven by the ADU motor (lower) through the belt.

# 5. CIRCUIT DESCRIPTION

## 5.1 PWA Block Diagram



ADU 05-01-01

The ADU PWA has the motor driving IC only and the other signals pass through the PWA.

IC1 and IC2 are driver IC's for the stepping motors and drive the ADU motors (upper/lower) on the output side according to the input signals. IC1 drives the ADU motor (lower), and IC2 the ADU motor (upper). Vref is the input to determine the value of the current which flows through each motor. The input voltage there determines the load (current value) to the motor.

ADCNT is a signal which detects connection of the ADU and connected to GND. When its connector is attached, the signal goes LOW so that the copier can confirm its connection.

## 5.2 Meaning of Signals

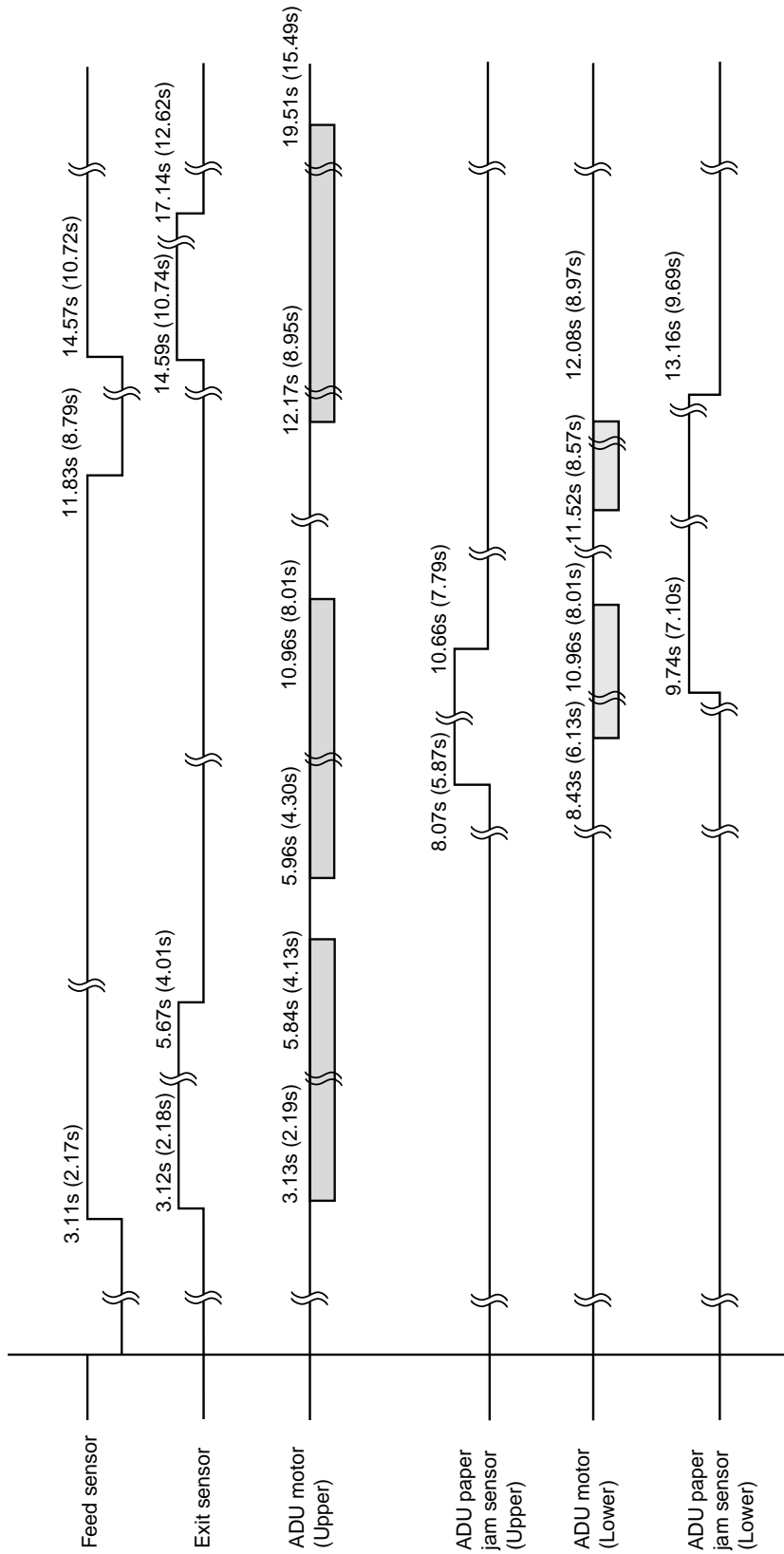
Signal name	Part name	Functional description	Status	Note
ADUFL	ADU paper jam sensor (Lower)	Detects the transport of paper (Lower)	High: Paper present	Photo sensor
ADUFU	ADU paper jam sensor (Upper)	Detects the transport of paper (Upper)	High: Paper present	Photo sensor
ADUCOVSW	ADU cover open switch	Detection of cover open/close status during jam processing, etc.	High: Open	Push switch
EXMA-D	ADU motor (Upper)	Drives the roller to transport paper (Upper)	-	PM type pulse motor
FDMA-D	ADU motor (Lower)	Drives the roller to transport paper (Lower)	-	PM type pulse motor

The ADU cover open switch is a switch which detects the open or close state of the cover. A push switch is used for the switch. The signal goes LOW when the cover is closed, and HIGH when it is open.

The ADU paper jam sensor (upper/lower) detects the presence or absence of paper in the transfer path. Photo sensors are used for the sensors. When paper passes, the sensor arm in the transfer path is pressed to turn on the sensor.

The ADU motor (lower) and ADU motor (upper) are 2-phase excitation PM type pulse motors (stepping motors) and operate according to the drive signals from the driver IC's (IC1, IC2).

### 5.3 Timing Chart



The values are data (reference values) applicable when the A4 size paper is used.  
 The value in brackets is for the DP2500 machine.

ADU 05-03-01

## 6. DISASSEMBLY AND REPLACEMENT

### [A] ADU hinge cover F/R

1. Remove 2 screws and detach ADU hinge cover F.

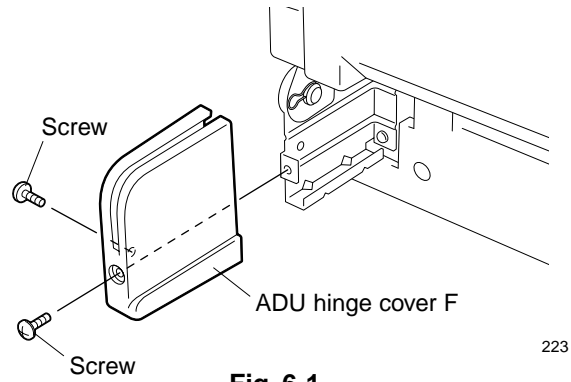


Fig. 6-1

2. Remove 2 screws and detach ADU hinge cover R.

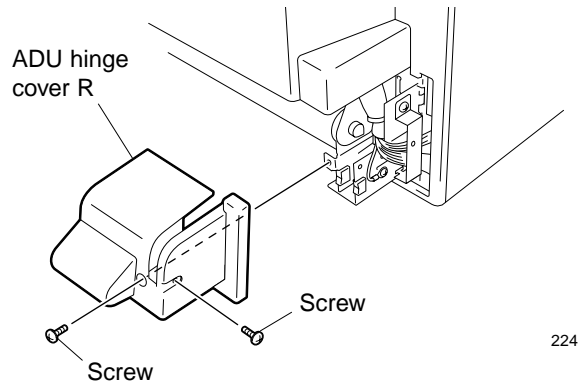


Fig. 6-2

### [B] ADU paper guide assembly

1. Pull ADU release lever to release one hook and open ADU.

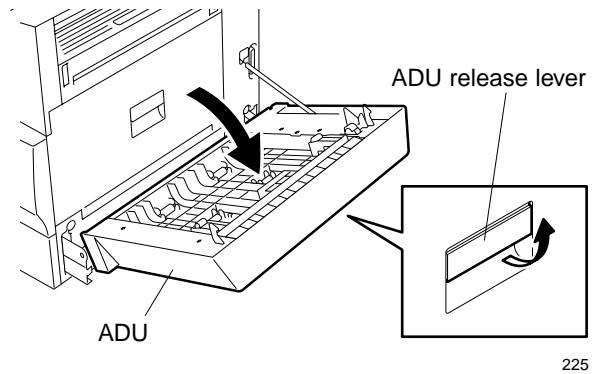


Fig. 6-3

2. Release 2 hooks and remove ADU paper guide assembly.

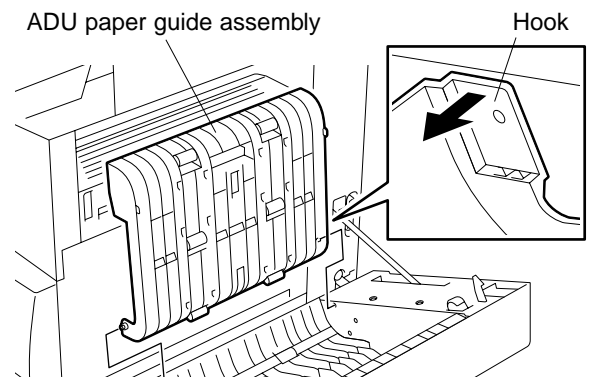
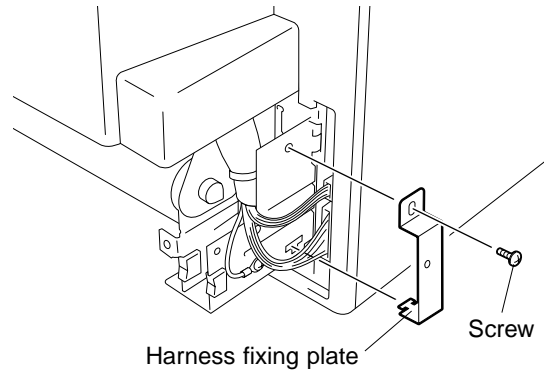


Fig. 6-4

**[C] ADU**

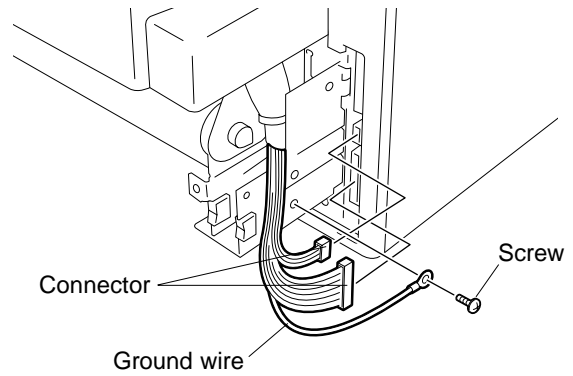
1. Detach ADU hinge cover F. (See Fig. 6-1)
2. Detach ADU hinge cover R. (See Fig. 6-2)
3. Remove one screw and detach harness fixing plate.



**Fig. 6-5**

227-1

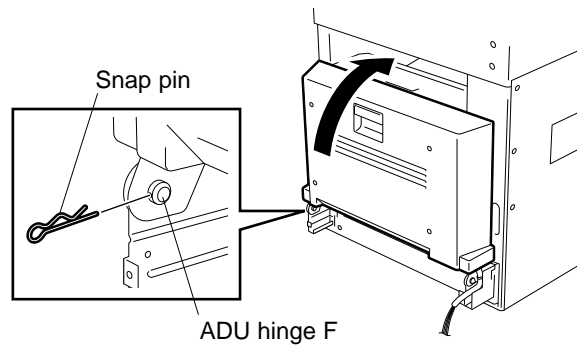
4. Remove one screw, detach the ground wire and the connector.



**Fig. 6-6**

227-2

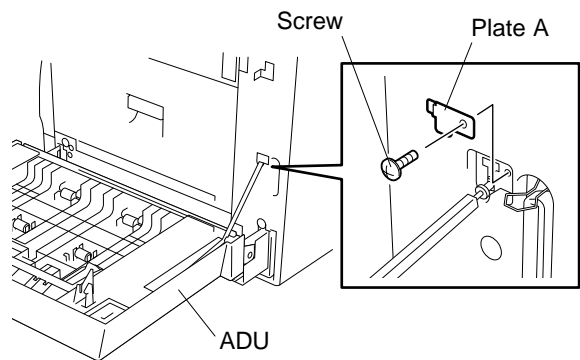
5. Remove stopper from ADU hinge F.



**Fig. 6-7**

228

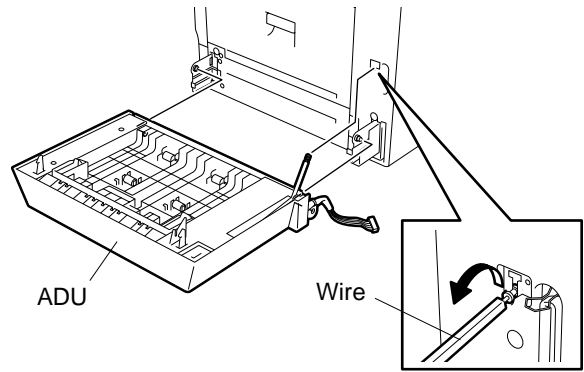
6. Open ADU, remove one screw, and remove plate A.



**Fig. 6-8**

229

7. Release one hook and detach the wire.
8. Release 2 hinges and remove ADU.

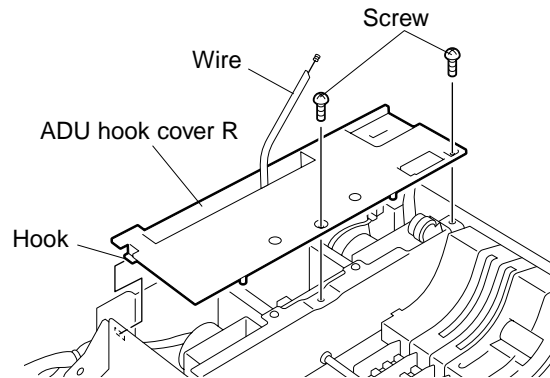


**Fig. 6-9**

230

**[D] ADU cover**

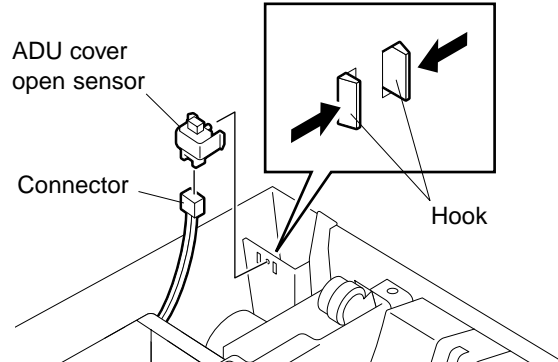
1. Detach ADU hinge cover F. (See Fig. 6-1)
2. Detach ADU hinge cover R. (See Fig. 6-2)
3. Remove ADU. (See Fig. 6-5 to 6-9)
4. Remove 2 screws, release one hook and wire, and detach ADU hook cover R.



**Fig. 6-10**

231

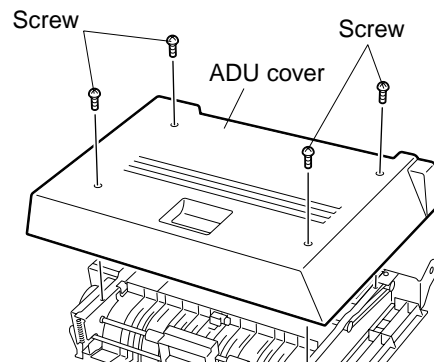
5. Release 2 hooks, detach one connector, and remove ADU cover open sensor.



**Fig. 6-11**

232

6. Remove 4 screws and detach ADU cover.

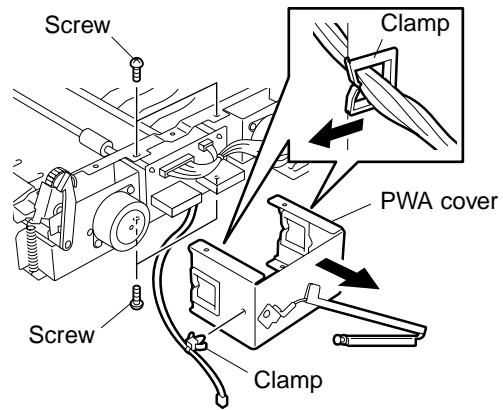


**Fig. 6-12**

233

### [E] ADU PWA

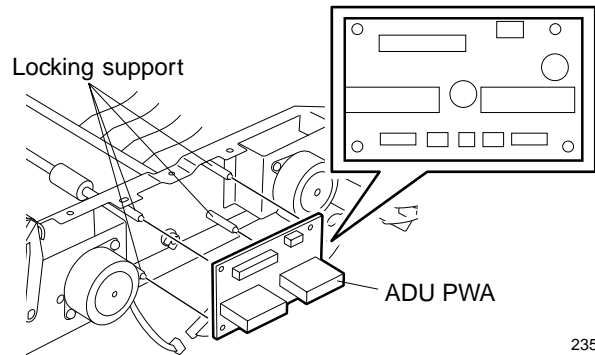
1. Detach ADU hinge cover F. (See Fig. 6-1)
2. Detach ADU hinge cover R. (See Fig. 6-2)
3. Remove ADU. (See Fig. 6-5 to 6-9)
4. Detach ADU cover. (See Fig. 6-10 to 6-12)
5. Remove 4 screws, release the harness from the clamp, and detach PWA cover.



234

Fig. 6-13

6. Detach all the connectors from ADU PWA, release 4 locking supports, and remove ADU PWA.



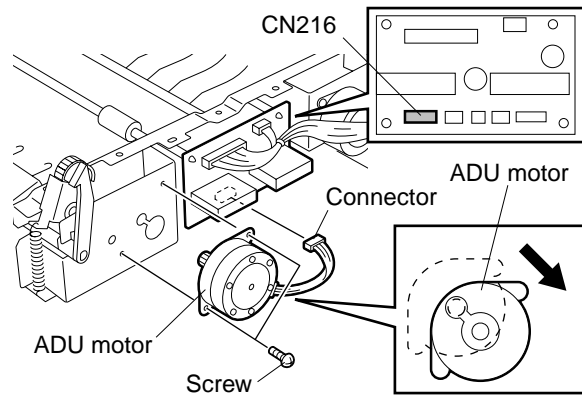
235

Fig. 6-14

### [F] ADU motor

1. Detach ADU hinge cover F. (See Fig. 6-1)
2. Detach ADU hinge cover R. (See Fig. 6-2)
3. Remove ADU. (See Fig. 6-5 to 6-9)
4. Detach ADU cover. (See Fig. 6-10 to 6-12)
5. Detach one connector from ADU PWA (CN216), remove 2 screws, remove ADU motor by sliding in the direction of the arrow.

**Note:** Apply 0.1g of GREASE (X5-6020) to the gear tooth surface.

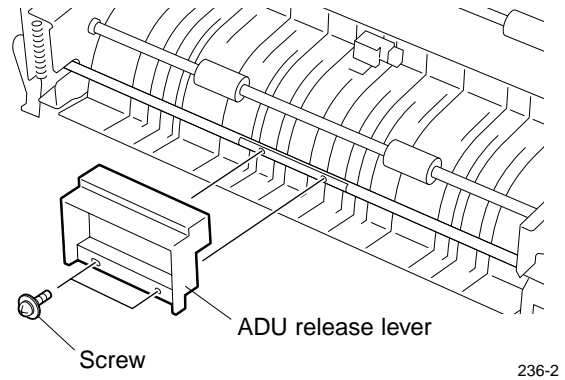


236-1

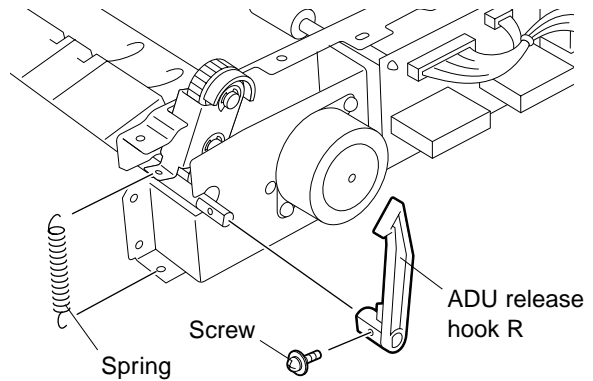
Fig. 6-15

**[G] ADU feed roller shaft upper/clutch 08S018-06CL**

1. Detach ADU hinge cover F. (See Fig. 6-1)
2. Detach ADU hinge cover R. (See Fig. 6-2)
3. Remove ADU paper guide assembly.  
(See Fig. 6-3 and 6-4)
4. Remove ADU. (See Fig. 6-5 to 6-9)
5. Detach ADU cover. (See Fig. 6-10 to 6-12)
6. Detach PWB cover. (See Fig. 6-13)
7. Remove 2 screws and remove ADU release lever.
8. Release Spring, remove one screw, and remove ADU release hook R.

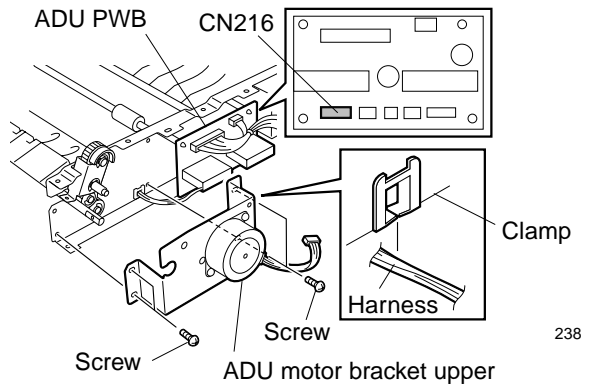


**Fig. 6-16**



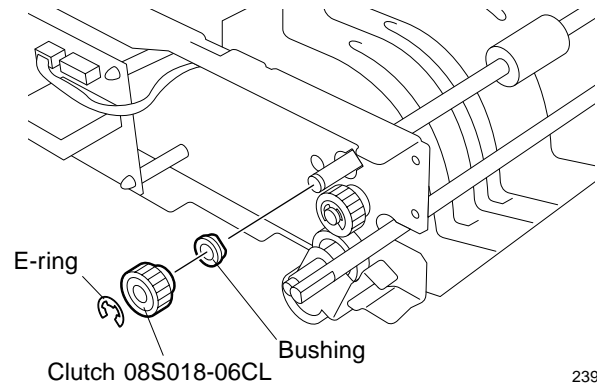
**Fig. 6-17**

9. Detach one connector from ADU PWA (CN216).
10. Remove 4 screws, release one clamp, and remove ADU motor bracket upper.



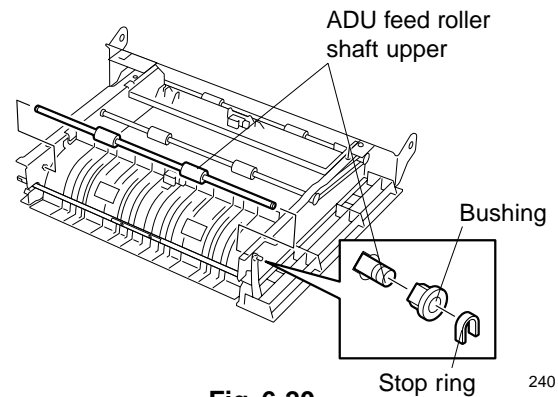
**Fig. 6-18**

11. Detach the E-ring, and remove clutch 08S018-06CL and bushing.



**Fig. 6-19**

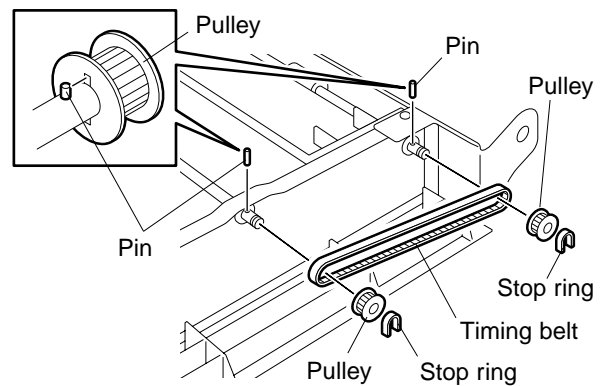
12. Detach stop ring, and remove bushing and ADU feed roller shaft upper.



**Fig. 6-20**

**[H] ADU feed roller shaft middle**

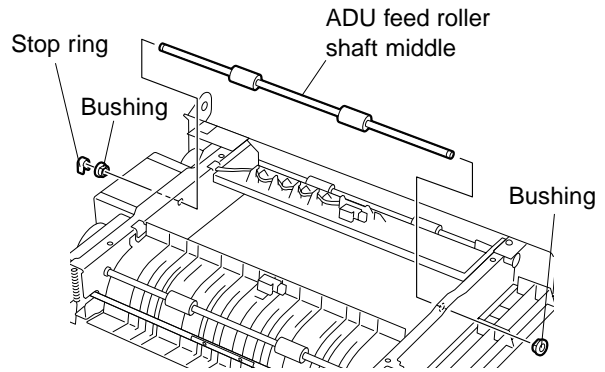
1. Detach ADU hinge cover F. (See Fig. 6-1)
2. Detach ADU hinge cover R. (See Fig. 6-2)
3. Remove ADU paper guide assembly. (See Fig. 6-3 and 6-4)
4. Remove ADU. (See Fig. 6-5 to 6-9)
5. Detach ADU cover. (See Fig. 6-10 to 6-12)
6. Detach PWA cover. (See Fig. 6-13)
7. Remove ADU PWA. (See Fig. 6-14)
8. Detach stop ring and remove pulley and timing belt.



**Fig. 6-21**

**Note:** Be sure to insert the pins when attaching.

- Detach stop ring, remove 2 bushings, and remove ADU feed roller shaft middle.

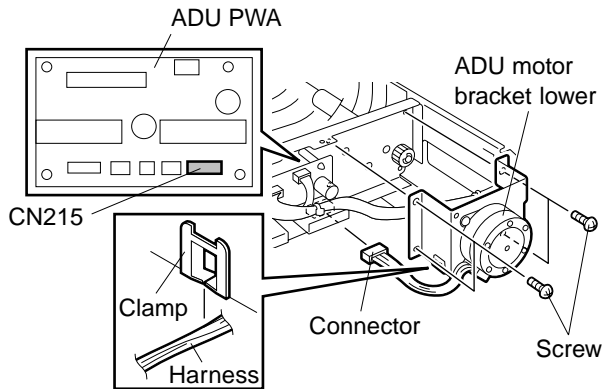


242

**Fig. 6-22**

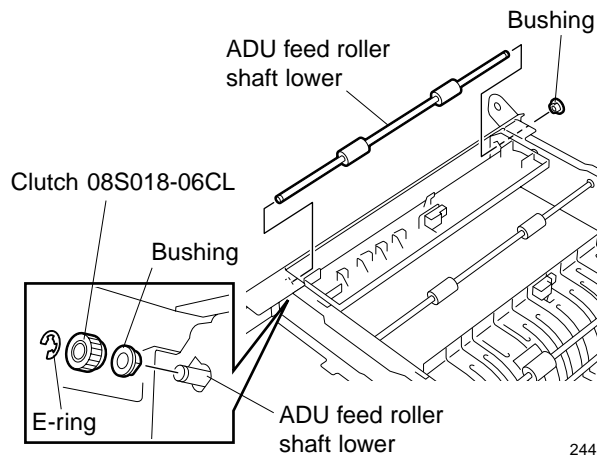
**[I] ADU feed roller shaft lower/clutch 08S018-06CL**

- Detach ADU hinge cover F. (See Fig. 6-1)
- Detach ADU hinge cover R. (See Fig. 6-2)
- Remove ADU paper guide assembly. (See Fig. 6-3 and 6-4)
- Remove ADU. (See Fig. 6-5 to 6-9)
- Detach ADU cover. (See Fig. 6-10 to 6-12)
- Detach PWB cover. (See Fig. 6-13)
- Remove timing belt. (See Fig. 6-21)
- Detach one connector from ADU PWA (CN215).
- Remove 4 screws, release one clamp, and remove ADU motor bracket lower.
- Detach the E-ring, remove clutch 08S018-06CL and 2 bushings, and remove ADU feed roller shaft lower.



243

**Fig. 6-23**



244

**Fig. 6-24**