

TOSHIBA

SERVICE MANUAL

PAPER FEED UNIT

MY-1015



General Precautions for Installation/Service/Maintenance for the MY-1015

The installation and service should be done by a qualified service technician.

1. When installing the MY-1015 to the Plain Paper Copier, be sure to follow the instructions described in the "Unpacking/Set-Up Procedure for the MY-1015" booklet which comes with each unit of the MY-1015.
2. The MY-1015 should be installed by an authorized/qualified person.
3. Before starting installation, servicing or maintenance work, be sure to turn off and unplug the copier first.
4. When servicing or maintaining the MY-1015, be careful about the rotating or operation sections such as gear, pulleys, sprockets, cams, belts, etc.
5. When parts are disassembled, reassembly is basically the reverse of disassembly unless otherwise noted in this manual or other related materials. Be careful not to reassemble small parts such as screws, washers, pins, E-rings, toothed washers to the wrong places.
6. Basically, the machine should not be operated with any parts removed or disassembled.
7. Delicate parts for preventing safety hazard problems (such as breakers, thermofuses, fuses, door switches, sensors, etc. if any) should be handled/installed/adjusted correctly.
8. Use suitable measuring instruments and tools.
9. During servicing or maintenance work, be sure to check the serial No. plate and other cautionary labels (if any) to see if they are clean and firmly fixed. If not, take appropriate actions.
10. The PC board must be stored in an anti-electrostatic bag and handled carefully using a wristband, because the ICs on it may be damaged due to static electricity. Before using the wrist band, pull out the power cord plug of the copier and make sure that there is no uninsulated charged objects in the vicinity.
11. For the recovery and disposal of used MY-1015, consumable parts and packing materials, it is recommended that the relevant local regulations/rules should be followed.
12. After completing installation, servicing and maintenance of the MY-1015, return the MY-1015 to its original state, and check operation.

Copyright 2000

TOSHIBA TEC CORPORATION

CONTENTS

1. SPECIFICATIONS	1-1
2. OUTLINE	2-1
2.1 Names of Various Components	2-1
2.2 Layout of Electrical Parts	2-2
2.3 Harness Connection Diagram	2-3
3. OPERATIONAL DESCRIPTION.....	3-1
3.1 General Operation	3-1
3.2 Block Diagram	3-1
3.3 Detection of Abnormal Status	3-2
3.3.1 Cover open/Close detection	3-2
3.3.2 Paper empty detection	3-2
3.3.3 Paper jam detection	3-2
3.3.4 Tray-up motor failure	3-2
3.4 Flow Charts	3-3
4. MECHANICAL DESCRIPTION.....	4-1
4.1 Paper Feed System	4-1
4.2 Drive System	4-2
5. CIRCUIT DESCRIPTION	5-1
5.1 Meaning of Signals	5-1
5.2 Timing Chart	5-2
6. DISASSEMBLY AND REPLACEMENT.....	6-1

1. SPECIFICATIONS

Function	: Automatic paper feed Single cassette front loading
Paper	: Size A3 to A5-R/LD to ST-R
	: Thickness Normal paper 64 to 80g/m ² (17 to 21 lbs)
Transport speed	: 258.18 mm/sec.
Cassette capacity	: Paper height 60.5 mm (Approx. 550 sheets)
Dimensions	: 530 (W) x 536 (D) x 112 (H) mm
Weight	: Approx. 7.7 kg
Power supply	: 5VDC, 24VDC (Supplied from copier)

2. OUTLINE

2.1 Names of Various Components

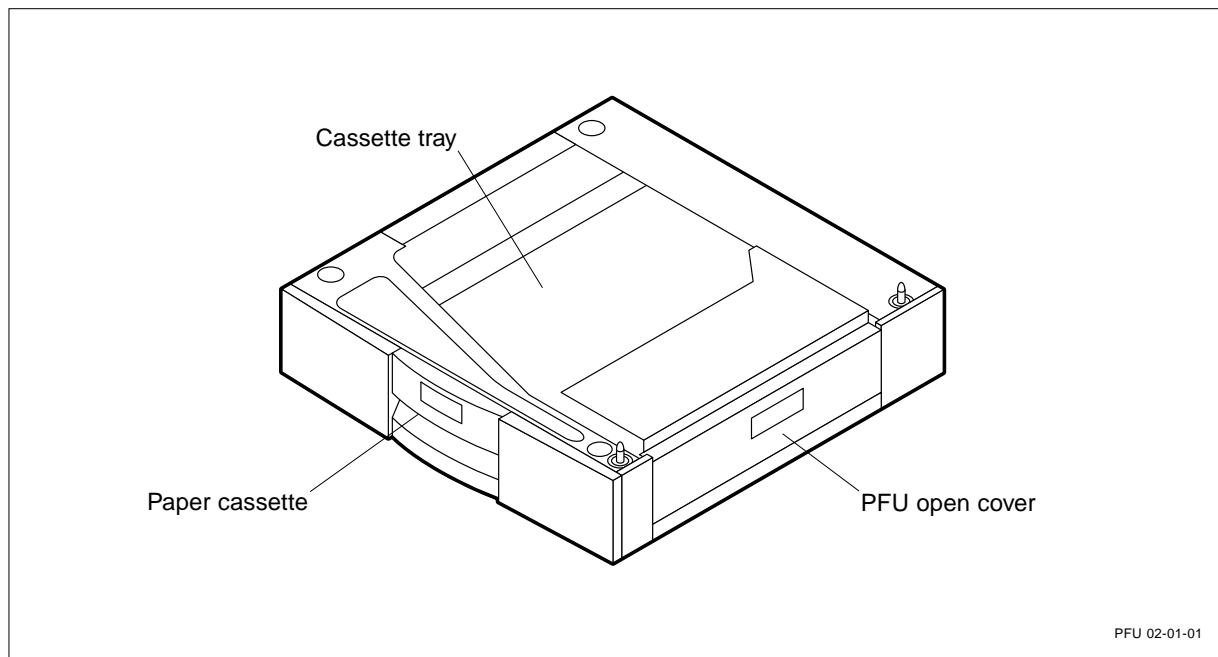

2.2 Layout of Electrical Parts

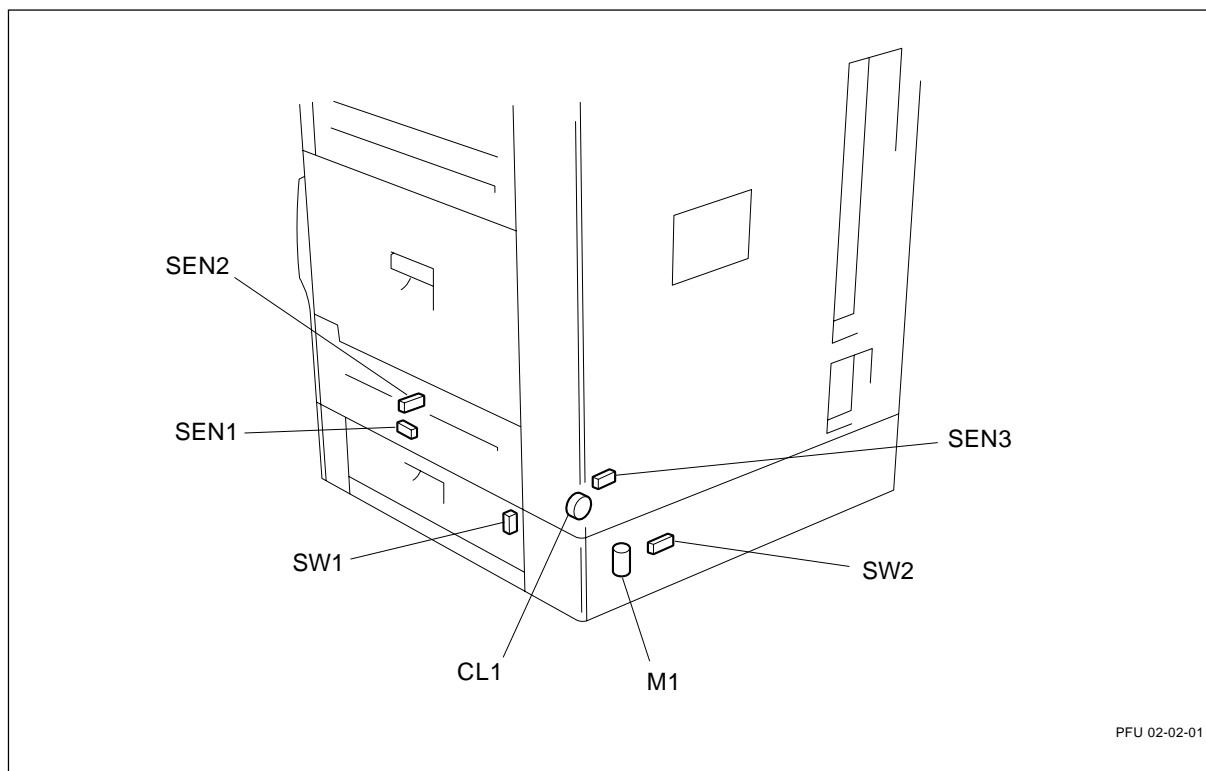

Symbols and functions of various devices

Symbol	Name	Function
SW1	2COV-SW PFU cover open switch	Detects the open/close state of the cover during jam processing, etc.
SW2	2CST-SW PFU cassette switch	Detects the open/close state of the cassette.
SEN1	2T-UP-SEN PFU tray-up sensor	Detects the lift-up of the tray.
SEN2	2PE-SEN PFU paper empty sensor	Detects the presence or absence of paper placed in the PFU cassette.
SEN3	2PNE-SEN PFU paper near empty sensor	Detects a paper near empty state of the PFU cassette. (option)
CL1	2PU-CLT PFU pickup clutch	Transmits driving force to the rollers to pick up and transport the paper.
M1	2T-UP-MOT PFU tray-up motor	Lifts up the tray of the PFU cassette.

2.3 Harness Connection Diagram

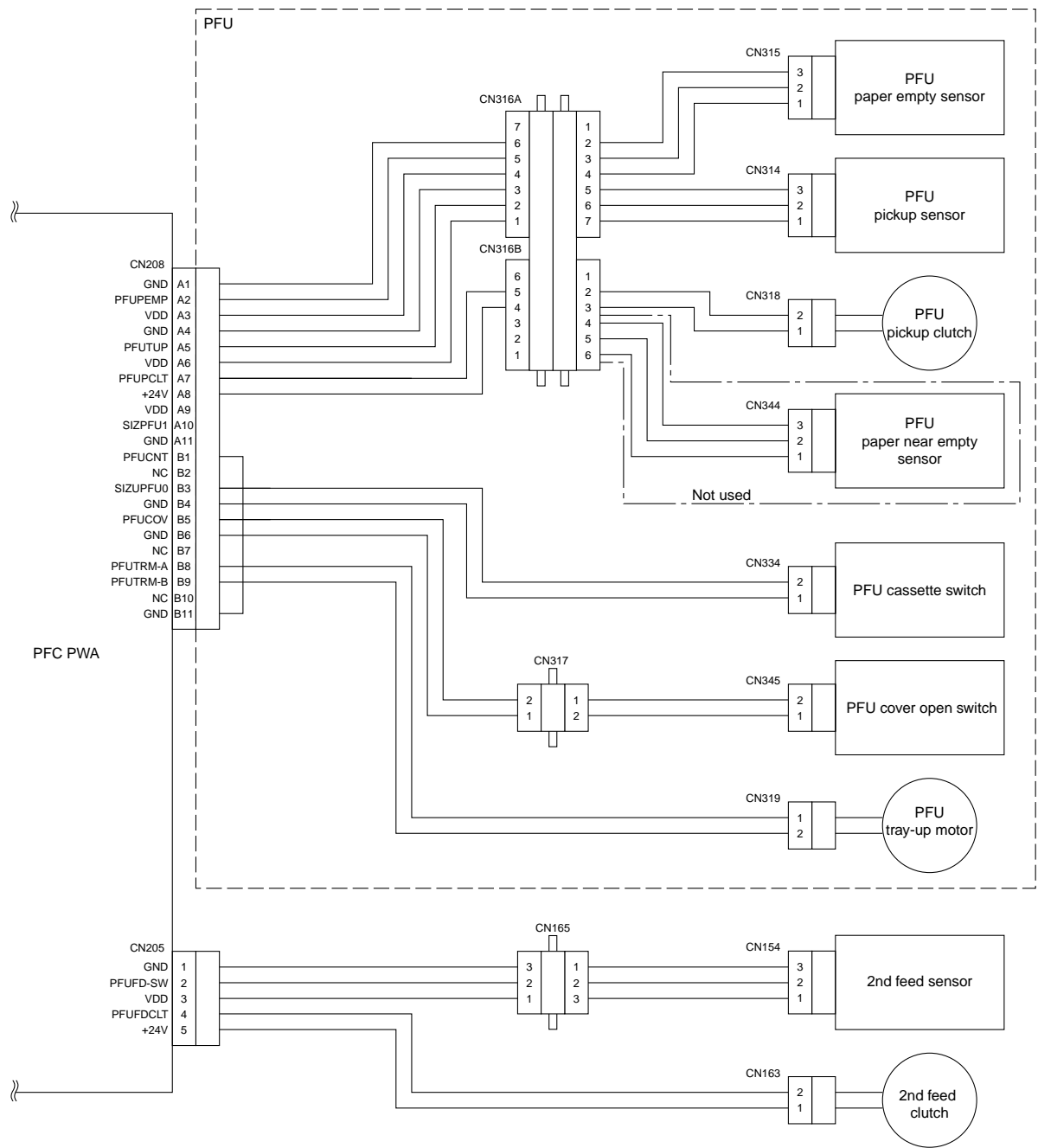

PFU 02-03-01

3. OPERATIONAL DESCRIPTION

3.1 General Operation

The PFU is an additional paper feed unit (2nd cassette) and installed under the standard cassette (copier). This unit has no PWA and its transport operation and detection are performed through the PFC PWA.

3.2 Block Diagram

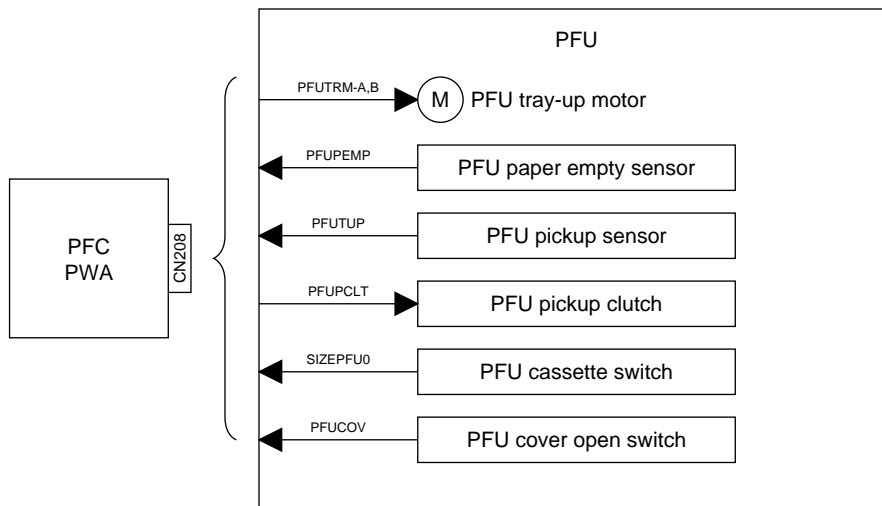

PFU 03-02-01

The PFU consists of the paper feed cassette, four sensors, one magnetic clutch, and one tray-up motor.

3.3 Detection of Abnormal Status

3.3.1 Cover open/Close detection

When the PFU cover open switch detects the open state of the cover, the copier detects it to stop the transport of paper.

3.3.2 Paper empty detection

When there is no paper in the cassette tray or the PFU paper empty sensor detects the absence of paper during printing, the operation is stopped. The absence of paper is detected only when the cassette is closed.

3.3.3 Paper jam detection

The PFU itself has no feed sensor but installation of the PFU allows the sensor (2nd cassette feed sensor) on the copier side to be effective. When transporting the paper, if the 2nd cassette feed sensor does not detect the passing of paper or the paper is left detected for a fixed time, the program will judge it to be paper jamming and stop the operation. The error state is reset by opening and then closing the cover.

3.3.4 Tray-up motor failure

If no paper is detected or the tray-up upper limit is not reached even if a specified amount of time has elapsed after the cassette is mounted, a tray-up motor failure will be assumed. To reset the error state, once draw out the cassette.

3.4 Flow Charts

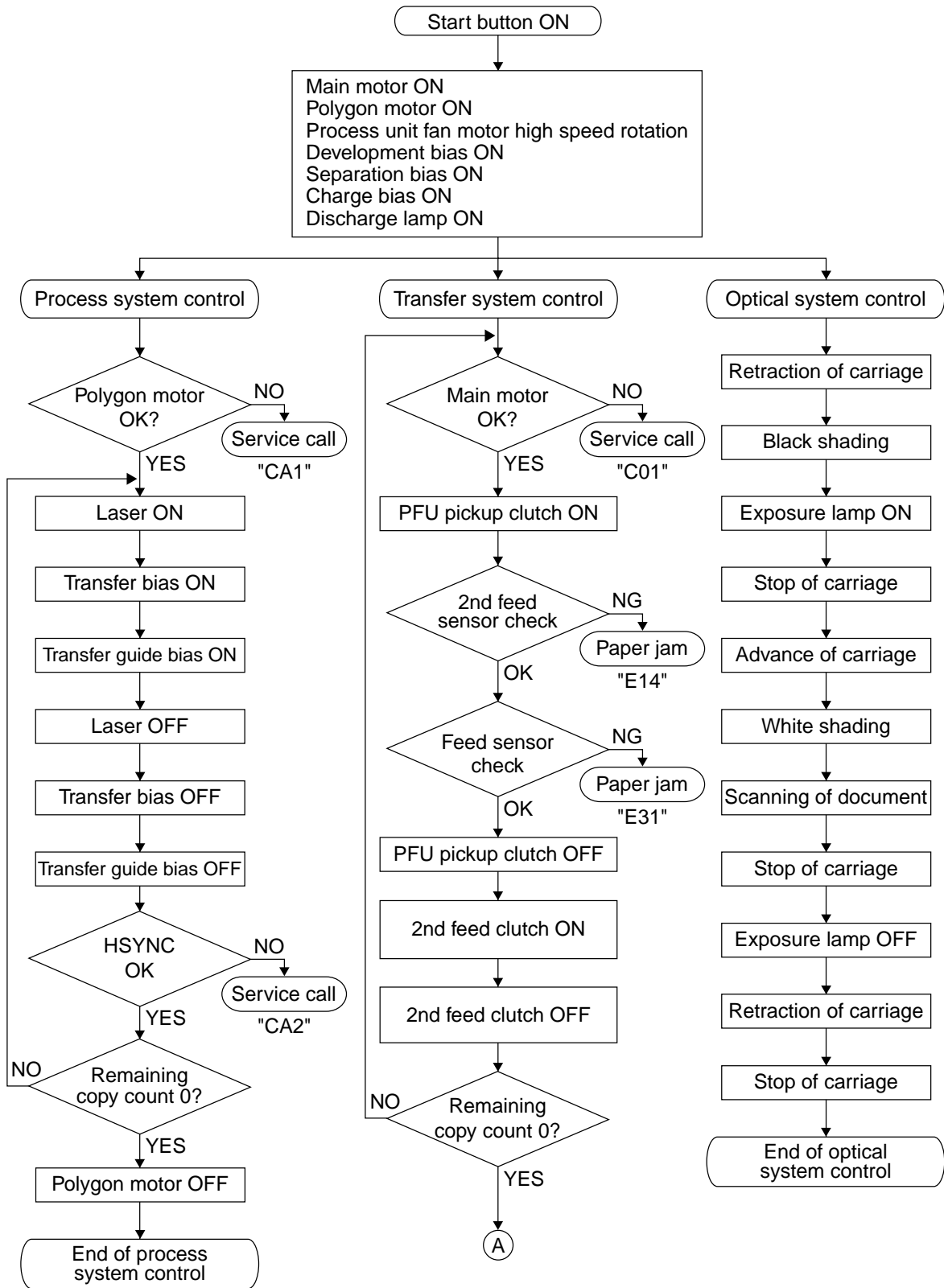

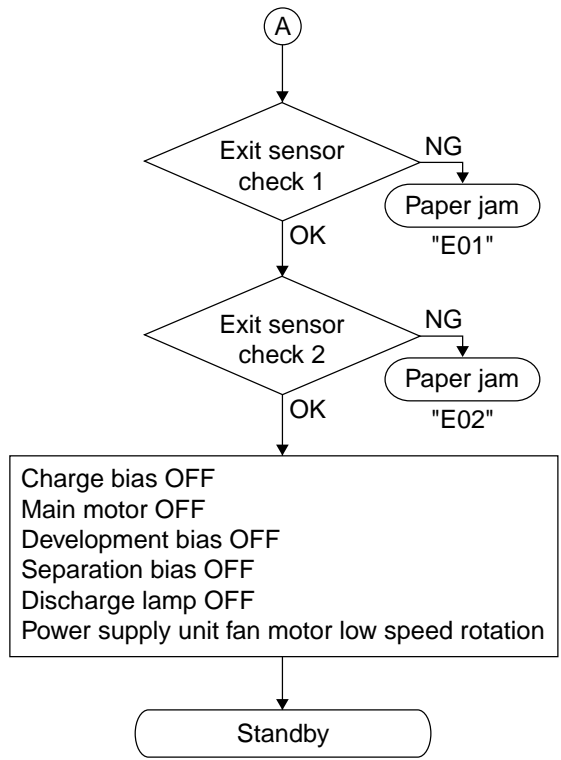

4. MECHANICAL DESCRIPTION

4.1 Paper Feed System

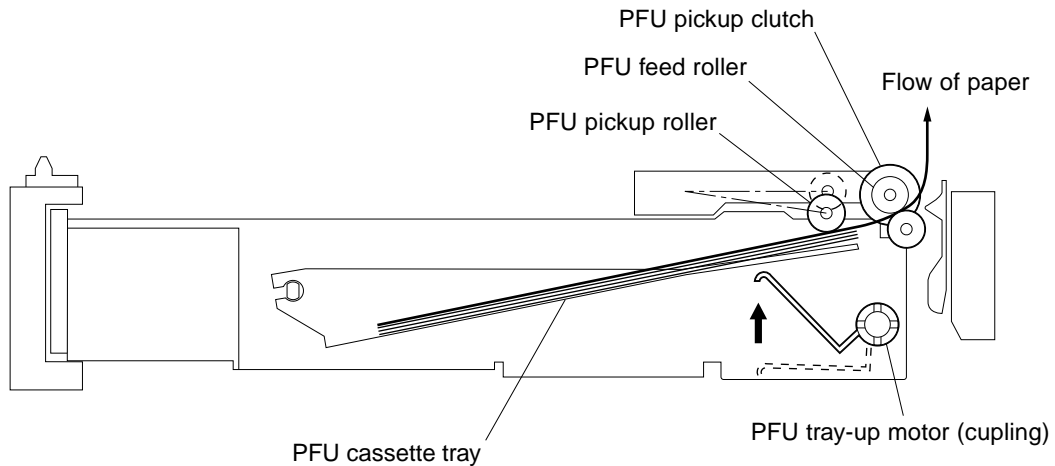

PFU 04-01-01

The PFU pickup clutch is used to turn ON and OFF the driving force of the main motor. It turns ON when picking up the paper and transmits the driving force to the feed roller and pickup roller through the shaft and belt. When the pickup clutch is turned ON to transport the paper, the feed roller and pickup roller turn and the pickup roller begins to pick up the paper. When picked up, the paper is transported by the feed roller and pulled into the transport path on the copier side.

The separate roller prevents the multi-feed of paper and contains a spring clutch. The roller separates sheets of paper to prevent the feeding of multiple sheets of paper at a time.

4.2 Drive System

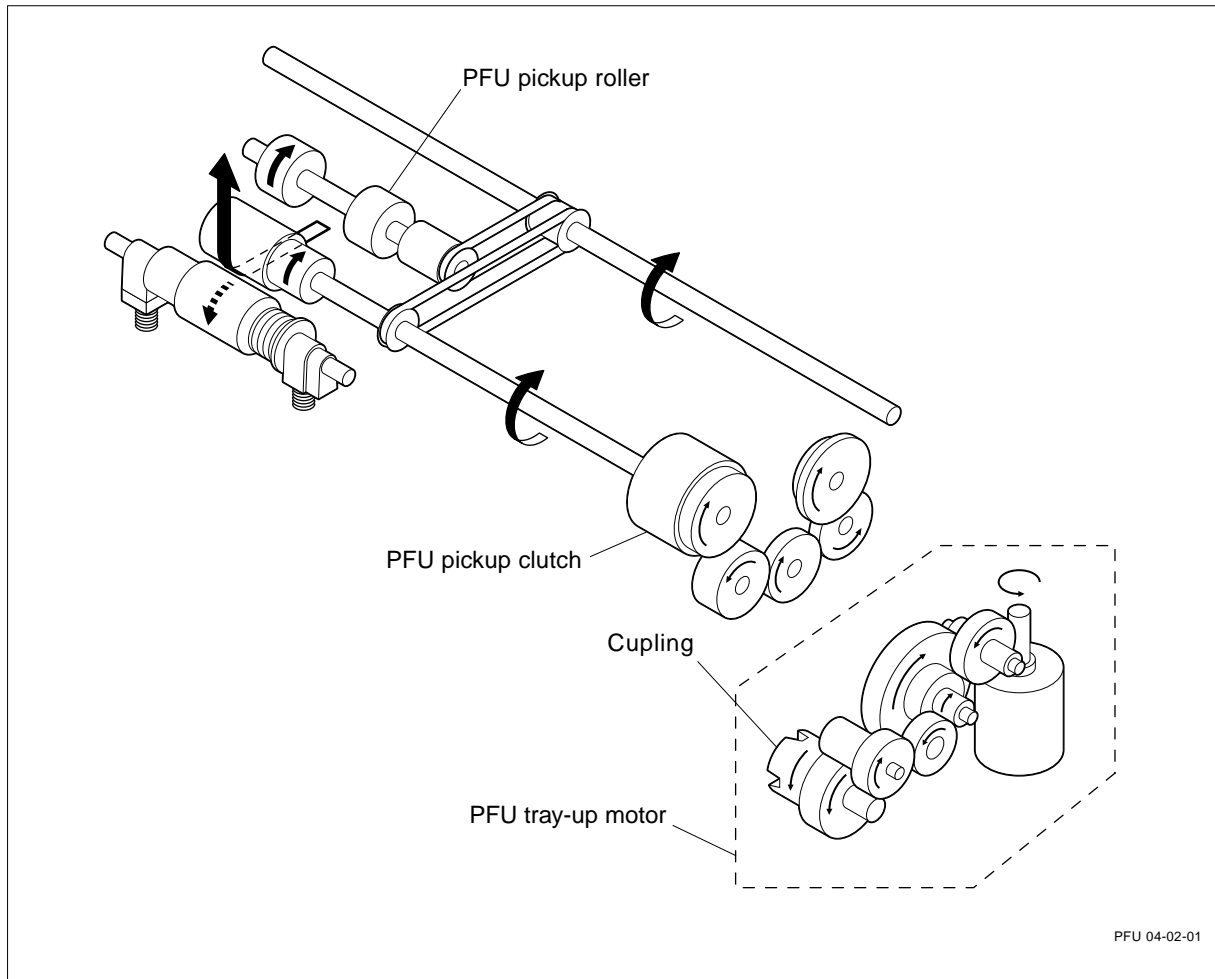

The PFU has no motor for transporting paper. Paper is transported by transmitting the driving force of the main motor of the copier to the gear. The driving force from the copier side is transmitted to the PFU pickup clutch through the gears (four pcs.). Installing the cassette causes the pickup roller to lower. The PFU pickup clutch turns ON and OFF the gear driving force from the copier. When picking up the paper, it turns ON to transmit the driving force to the feed roller and pickup roller through the shaft and belt. When the pickup roller turns, the paper is picked up from the cassette and brought to the transport path.

The tray-up operation is performed by the PFU tray-up motor. Consisting of the DC motor, worm gear, gear, coupling, etc., the PFU tray-up motor is housed within a case as a unit. When the cassette is installed, the coupling of this motor unites with the coupling of the cassette to transmit the motor rotation to the arm under the cassette and lift the cassette tray.

5. CIRCUIT DESCRIPTION

5.1 Meaning of Signals

Signal Name	Part Name	Functional Description	Status	Note
PFUCOV	PFU cover open switch	Detects the open/close state of the cover during jam processing, etc.	High: Open	Push switch
SIZPFU0	PFU cassette switch	Detects the open/close state of the cassette.	Low: Cassette present	Push switch
PFUTUP	PFU pickup sensor	Detects the lift-up of the cassette.	High: Paper feed enabled	Photo sensor
PFUPEMP	PFU paper empty sensor	Detects the presence or absence of paper placed in the PFU cassette.	High: Paper absent	Photo sensor
PFUPCLT	PFU pickup clutch	Operation signal for feed clutch.	Low: ON	Magnetic clutch
PFUTRM-A, B	PFU tray-up motor	Lifts up the tray of the PFU cassette.	Low, High = Up	Brush motor

The PFU cover open switch detects the open or close state of the cover. A push switch is used for the switch. The signal goes LOW when the cover is closed, and HIGH when it is open.

The PFU cassette switch is a switch which detects the open or close state of the cassette. A push switch is used for the switch. The signal goes LOW when the cassette is mounted, and HIGH when it is open.

The PFU pickup sensor is a switch which detects the lift-up of the cassette. A photo sensor is used for the switch. Paper feed is enabled when the signal is at "High" level.

The PFU paper empty sensor detects the presence or absence of paper. A photo sensor is used for the sensor. There is no paper when the signal is at "High" level.

PFU pickup clutch is an operation signal for the feed clutch and drives the magnetic clutch. Driving force is transmitted to the pickup roller when the signal is at "Low" level.

The PFU tray-up motor lifts the tray of the cassette. The combination of the two signals permits setting of lifting, braking, and OFF.

5.2 Timing Chart

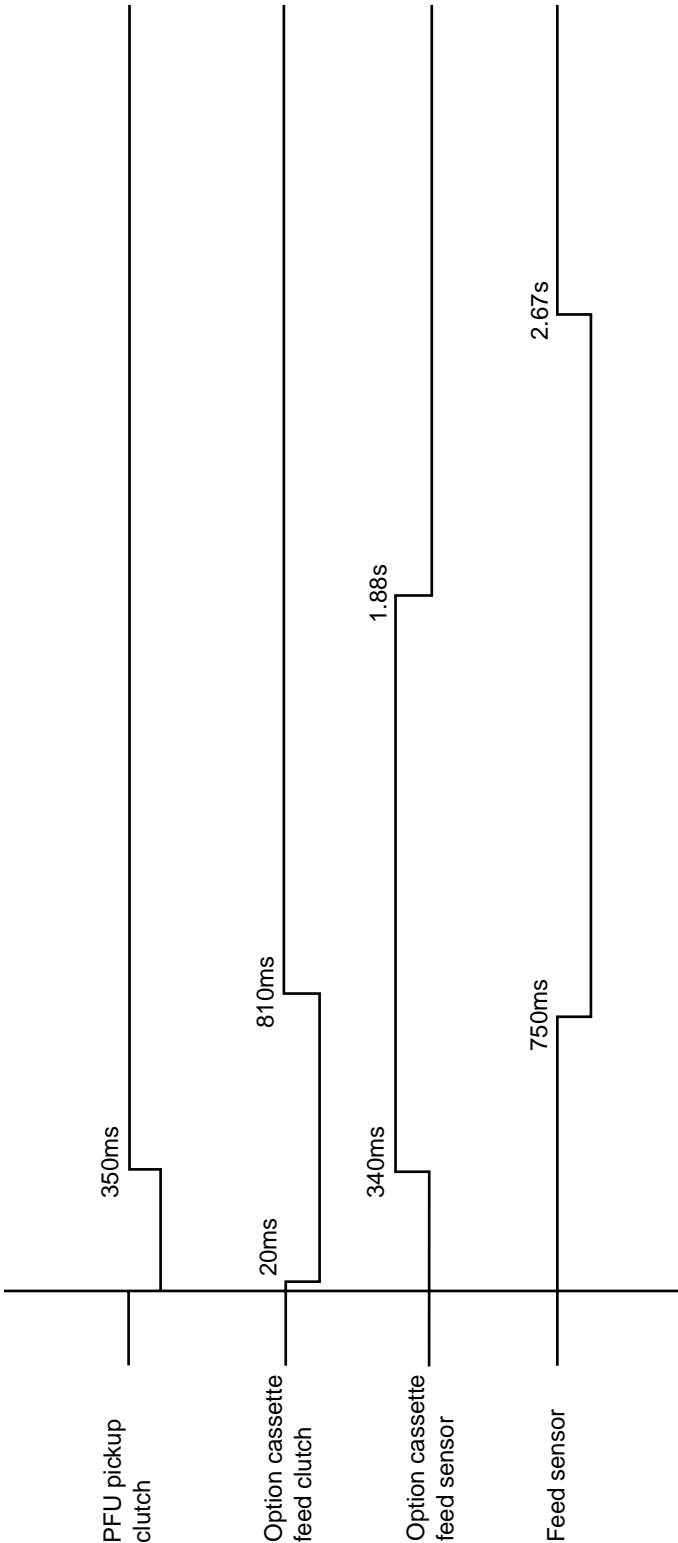

The values are data (reference values) applicable when the A4 size paper is used.

6. DISASSEMBLY AND REPLACEMENT

[A] PFU rear cover

1. Remove 3 screws, release 2 hooks, and detach PFU rear cover.

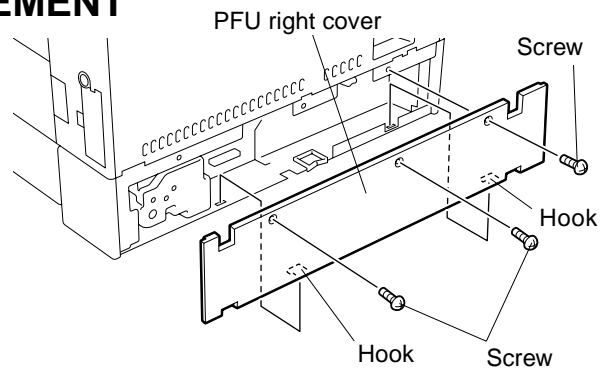

Fig. 6-1

193

[B] PFU right cover F

2. Open PFU open cover, remove 2 screws, and detach PFU right cover F.

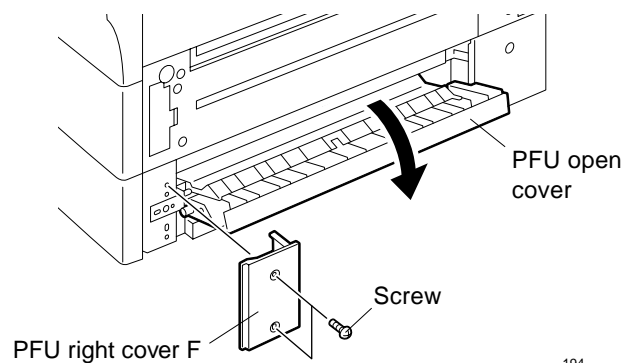

Fig. 6-2

194

[C] PFU right cover R

1. Remove 2 screws and detach PFU right cover R.

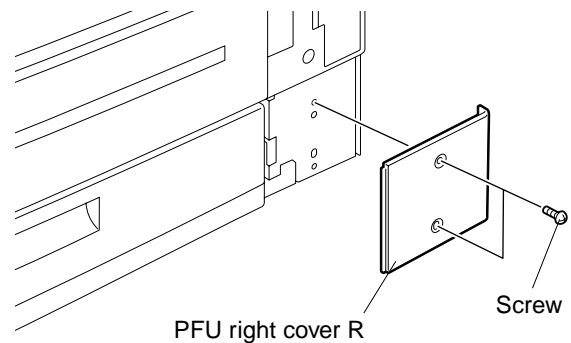

Fig. 6-3

195

[D] PFU blind cover

Note: This cover cannot be used with PFP-1 installed.

1. Detach PFU right cover R. (See Fig. 6-3)
2. Release 2 hooks and detach PFU blind cover.

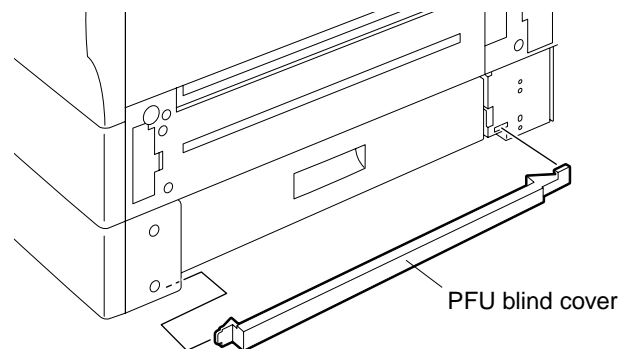

Fig. 6-4

196

[E] PFU open cover

1. Detach PFU right cover F. (See Fig. 6-2)
2. Release 2 hooks and detach PFU switch cover.

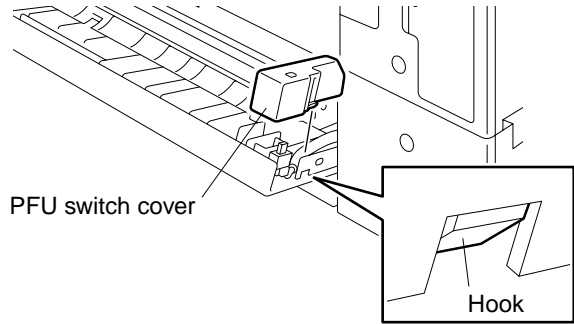

Fig. 6-5

197

3. Release 2 hook, detach one connector, and re-move PFU open cover switch.

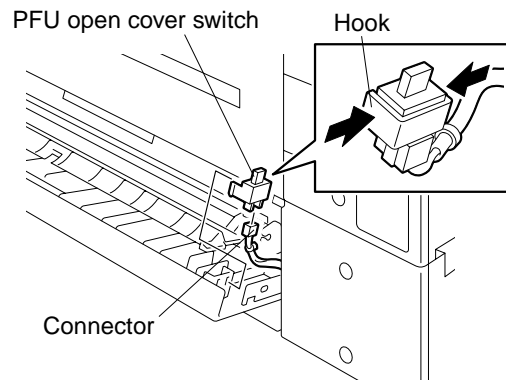

Fig. 6-6

198

4. Remove one screw, release bracket hook F, and detach PFU open cover.

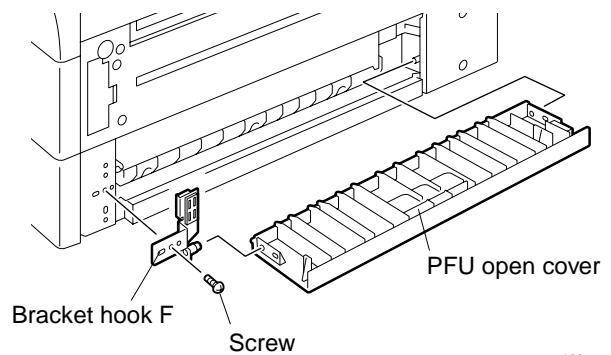

Fig. 6-7

199

[F] PFU left cover R

1. Detach PFU rear cover. (See Fig. 6-1)
2. Release 5 hooks and detach PFU left cover R.

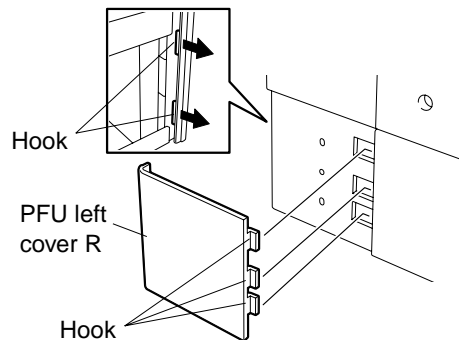
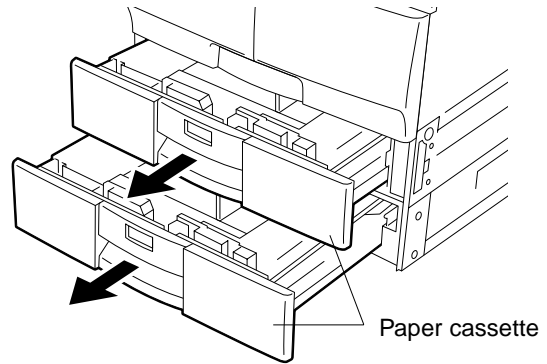

Fig. 6-8

200

[G] PFU left cover

1. Detach PFU rear cover. (See Fig. 6-1)
2. Remove paper cassette of PFU and paper cassette of the copier.



201

Fig. 6-9

3. Remove 17 screws and detach rear cover.

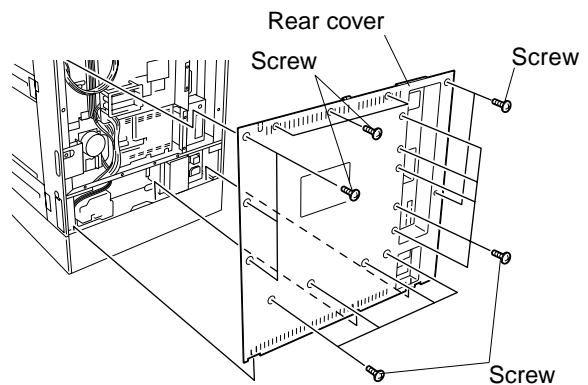

202

Fig. 6-10

4. Detach 3 harnesses from PFC PWA (CN206/CN207/CN208).
5. Remove one screw and detach the ground wire from the copier.

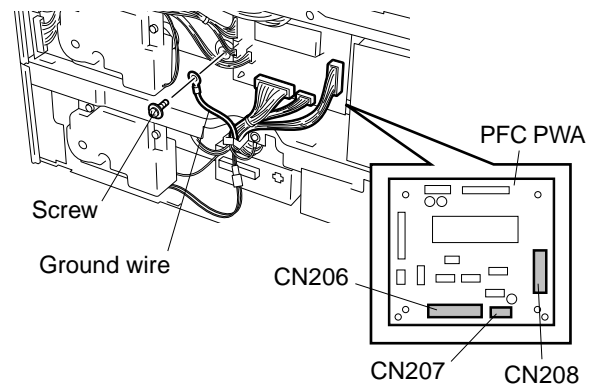

203

Fig. 6-11

6. Remove 2 screws and remove fixing plate R.

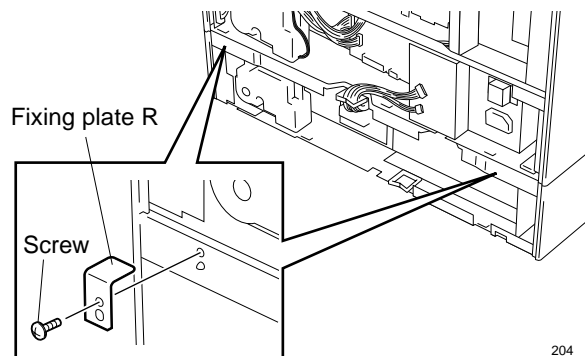

204

Fig. 6-12

- Remove 4 screws and remove fixing plate F.

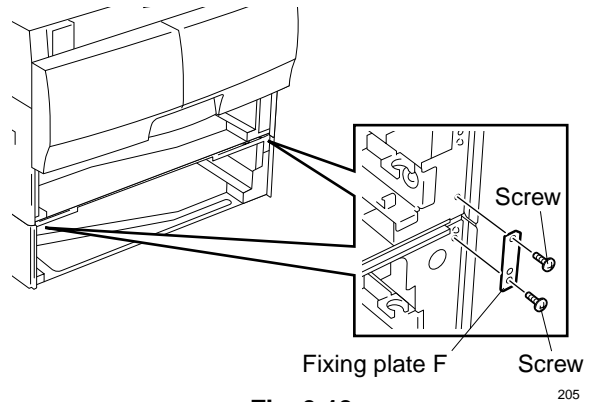

Fig. 6-13

- Remove PFU from the copier.

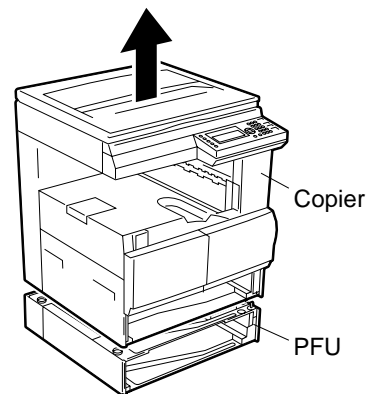

Fig. 6-14

- If a PFP-1 (KD-1009) or the LCF (KD-1010) is attached to the copier, detach it.
- Detach PFU rear cover (See Fig. 6-1)
- Detach PFU left cover R. (See Fig. 6-8)
- Remove 10 screws, release 10 tabs, and detach PFU left cover.

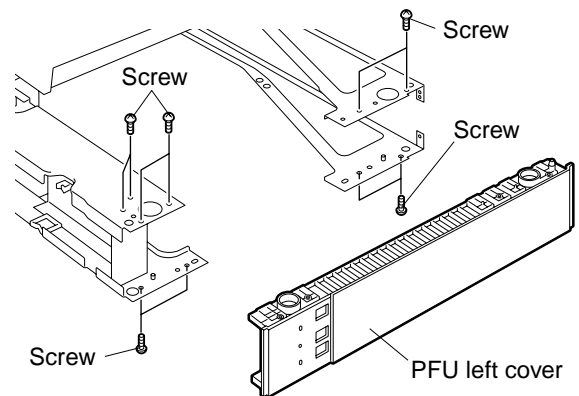

Fig. 6-15

[H] Tray-up assembly

- Detach PFU rear cover. (See Fig. 6-1)
- Remove paper cassette of PFU. (See Fig. 6-9)
- Remove 2 screws, detach the relay connector, and remove tray-up assembly.

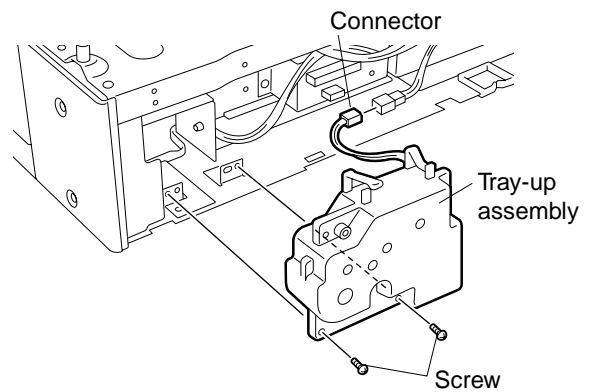

Fig. 6-16

[I] PFU joint gear assembly

1. Detach PFU rear cover. (See Fig. 6-1)
2. Remove paper cassette of PFU. (See Fig. 6-9)
3. Remove tray-up assembly. (See Fig. 6-16)
4. Release the clamp.
5. Remove 2 screws, release the tab, and remove PFU joint gear assembly.

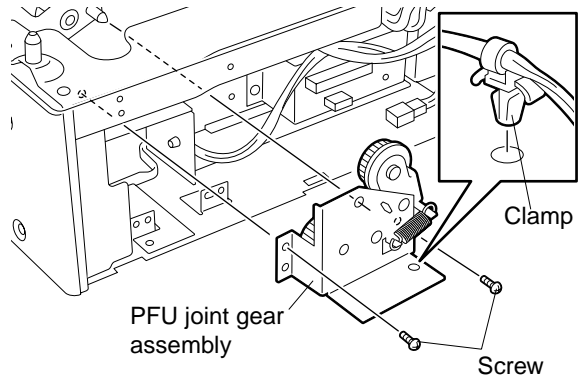

Fig. 6-17

209

[J] PF separate roller

1. Remove paper cassette of PFU and paper cassette of the copier. (See Fig. 6-9)
2. Remove one screw and remove PF pickup assembly.

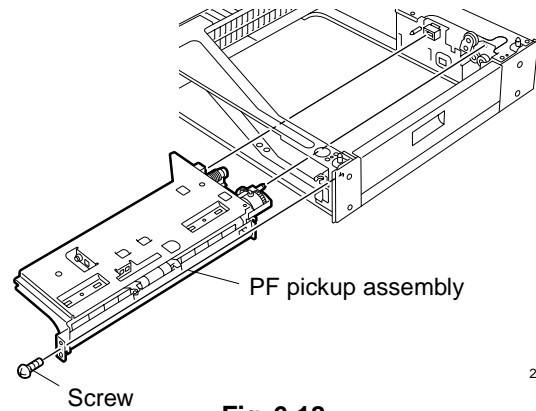

Fig. 6-18

210

3. Remove one screw and remove PF separator holder assembly.

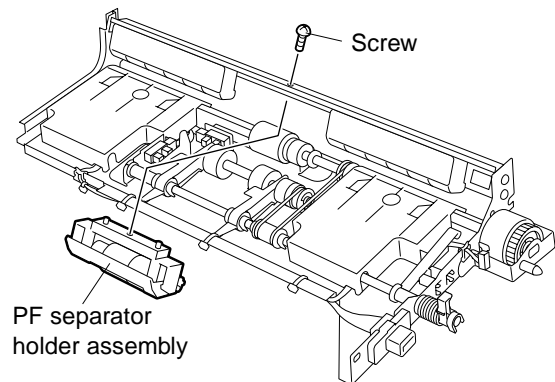

Fig. 6-19

211

4. Pull up and take out separate roller lever.
5. Remove arbor F, draw out shaft, and remove separate roller, separate spring, arbor R, and spring cover in this order.

Notes: 1. To detach/attach the separate roller from/to the separate spring, rotate the separate roller in the direction of the arrow.

2. Since the separate spring is coated with oil, the separate roller should not be touched by the separate spring.

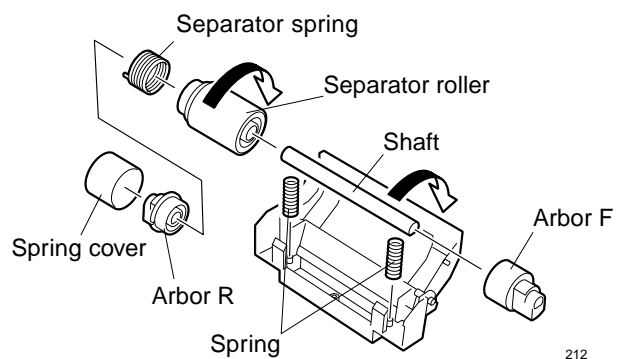

Fig. 6-20

212

[K] Pickup feed roller

1. Remove paper cassette of PF and paper cassette of the copier. (See Fig. 6-9)
2. Remove PF pickup assembly. (See Fig. 6-18)
3. Remove PF separate holder assembly. (See Fig. 6-19)
4. Detach stop ring and remove pickup feed roller.

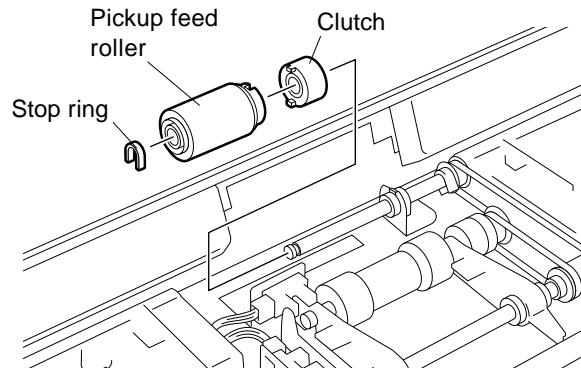

Fig. 6-21

213

[L] Pickup roller

1. Remove paper cassette of PFU and paper cassette of the copier. (See Fig. 6-9)
2. Remove PF pickup assembly. (See Fig. 6-18)
3. Release the two hooks.
4. Release the timing belt and remove the pickup roller shaft assembly.

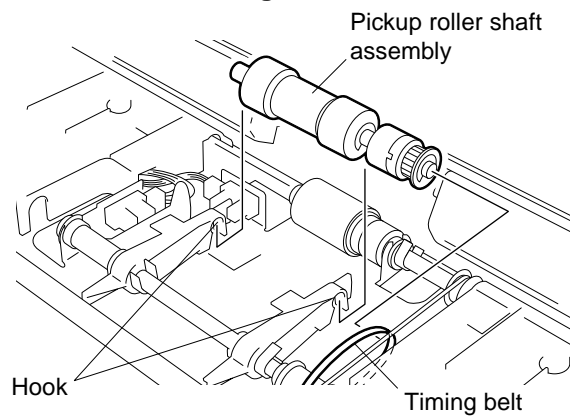

Fig. 6-22

214

5. Detach the E-ring and remove pickup roller gear and clutch.

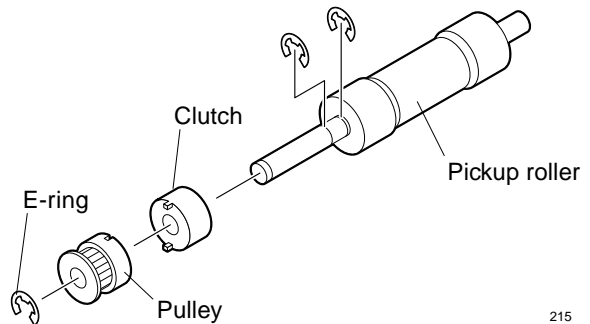

Fig. 6-23

215

TOSHIBA

TOSHIBA TEC CORPORATION

1-1, KANDA NISHIKI-CHO, CHIYODA-KU, TOKYO, 101-8842 JAPAN