

S520 / S750 S820 / S900 SERVICE MANUAL

REVISION 0

Canon

QY8-1379-000

DEC. 2001

122001 GR 0.30-0

S520 / S750
S820 / S900
SERVICE
MANUAL

Canon

Application

This manual has been issued by Canon Inc. for qualified persons to learn technical theory, installation, maintenance, and repair of products. This manual covers all localities where the products are sold. For this reason, there may be information in this manual that does not apply to your locality.

Corrections

This manual could include technical inaccuracies or typographical errors due to improvements or changes in the products. When changes occur in applicable products or in the content of this manual, Canon will release technical information as the need arises. In the event of major changes in the contents of this manual over a long or short period, Canon will issue a new edition of this manual.

The following paragraph does not apply to any countries where such provisions are inconsistent with local law.

Trademarks

The product names and company names described in this manual are the registered trademarks of the individual companies.

Copyright

This manual is copyrighted with all rights reserved. Under the copyright laws, this manual may not be copied, reproduced or translated into another language, in whole or in part, without the written consent of Canon Inc., except in the case of internal business use.

Copyright © 2001 by Canon Inc.

CANON INC.

i Printer Technical Support Dept. 11,21

16-1, Shimonoge 3-chome, Takatsu-ku, Kawasaki, Kanagawa 213-8512, Japan

This manual has been produced on an Apple Power Macintosh Power Macintosh 7300/180 computer and Apple LaserWriter II NTX-J laser beam printer; printing films were printed on Agfa SelectSet Avantra 25. All page layout and illustration data was saved on a YANO 640MO drive system using NJ 640MO and Mitsubishi MR230MI discs.

Logos and illustrations were created with MACROMEDIA FREEHAND 7.0J. All documents and page layouts were created with QuarkXPress 3.3 Japanese version.

I. ABOUT THIS MANUAL

This manual consists of four parts containing information for servicing the product.

Part 1: Product Specifications

Product overview and specifications.

Product
Specifications

Part 2: Troubleshooting

A guide to troubleshooting the product and identifying parts needing replacement. Troubleshooting solutions are listed according to the error indications displayed by the status indicator and by problem descriptions.

Troubleshooting

Part 3: Technical Reference

Block diagrams and information on the hardware's new technologies.

Technical
Reference

Part 4: Appendix

Pin configurations.

Appendix



REF.

Disassembly and reassembly procedures are not fully covered in this manual. Refer to the illustrations in the separate Parts Catalog as well.

II. TABLE OF CONTENTS

Page	<i>Part 1: PRODUCT SPECIFICATIONS</i>
	(S900)
1 - 1	1. PRODUCT OVERVIEW
1 - 1	1.1 Product Overview
1 - 1	1.2 Special Features
1 - 2	2. SPECIFICATIONS
1 - 2	2.1 Printer Specifications
1 - 2	2.1.1 Printer specifications
1 - 3	2.1.2 Printer service life
1 - 3	2.1.3 Print head service life
1 - 4	2.2 Paper Specifications
1 - 4	2.2.1 Paper sizes and weights
1 - 4	2.2.2 Paper types and settings
1 - 5	2.2.3 Printable area
1 - 6	2.3 Print Head Specifications
1 - 6	2.4 Printer and Scanner Drivers
1 - 7	3. PRODUCT CODE LIST
	(S820)
1 - 9	1. PRODUCT OVERVIEW
1 - 9	1.1 Product Overview
1 - 9	1.2 Special Features
1 -10	2. SPECIFICATIONS
1 -10	2.1 Printer Specifications
1 -10	2.1.1 Printer specifications
1 -11	2.1.2 Printer service life
1 -11	2.1.3 Print head service life
1 -12	2.2 Paper Specifications
1 -12	2.2.1 Paper sizes and weights
1 -12	2.2.2 Paper types and settings
1 -12	2.2.3 Printable area
1 -13	2.3 Print Head Specifications
1 -13	2.4 Printer and Scanner Drivers
1 -14	3. PRODUCT CODE LIST
	(S750)
1 -15	1. PRODUCT OVERVIEW
1 -15	1.1 Product Overview
1 -15	1.2 Special Features
1 -16	2. SPECIFICATIONS
1 -16	2.1 Printer Specifications
1 -16	2.1.1 Printer specifications
1 -16	2.1.2 Printer service life
1 -17	2.1.3 Print head service life
1 -18	2.2 Paper Specifications
1 -18	2.2.1 Paper sizes and weights
1 -18	2.2.2 Paper types and settings
1 -18	2.2.3 Printable area
1 -19	2.3 Print Head Specifications
1 -19	2.4 Printer and Scanner Drivers
1 -20	3. PRODUCT CODE LIST

Page

(S520)

1 -21	1. PRODUCT OVERVIEW
1 -21	1.1 Product Overview
1 -21	1.2 Special Features
1 -22	2. SPECIFICATIONS
1 -22	2.1 Printer Specifications
1 -22	2.1.1 Printer specifications
1 -22	2.1.2 Printer service life
1 -23	2.1.3 Print head service life
1 -23	2.2 Paper Specifications
1 -23	2.2.1 Paper sizes and weights
1 -23	2.2.2 Paper types and settings
1 -23	2.2.3 Printable area
1 -23	2.3 Print Head Specifications
1 -23	2.4 Printer and Scanner Drivers
1 -24	3. PRODUCT CODE LIST

Part 2: TROUBLESHOOTING

2 - 1	1. PRINTER OPERATION
2 - 1	1.1 Printer Operation
2 - 1	1.2 Status Indicator
2 - 2	1.3 Simple Printer Operations
2 - 2	1.3.1 Cleaning operation
2 - 2	1.3.2 Printing the nozzle check pattern
2 - 4	1.3.3 Roller cleaning operation
2 - 5	2. SERVICING
2 - 5	2.1 Before Troubleshooting
2 - 6	2.2 Detectable Problems from System Start to Exit
2 - 9	2.3 Troubleshooting Problems
2 -10	2.4 Troubleshooting Error Indications
2 -13	3. DISASSEMBLY AND REASSEMBLY
2 -13	3.1 Cautions for Disassembly and Reassembly
2 -13	3.1.1 Cautions against ink stains (ink path/ink mist)
2 -13	3.1.2 Damage due to static electricity
2 -13	3.1.3 Deformation of spur tips
2 -14	3.2 Exploded View
2 -15	3.3 Disassembly and Reassembly
2 -15	3.3.1 Carriage lock release
2 -16	3.3.2 Removing and installing tap screws
2 -16	3.3.3 Installing and removing the timing slit strip
2 -17	3.3.4 Handling the encoder film
2 -17	3.3.5 Removing and installing the logic board
2 -18	3.3.6 Removal of red screws prohibited
2 -18	3.3.7 Installing the logic board cover
2 -19	3.3.8 Installing the control ROM cover
2 -20	4. ADJUSTMENTS AND SETTINGS AFTER DISASSEMBLY AND REASSEMBLY, AND CONFIRMATION OF OPERATION
2 -20	4.1 Adjustments and Settings after Disassembly and Reassembly
2 -20	4.1.1 Items for adjustment (per necessity/locations/tools)
2 -21	4.1.2 If EEPROM settings adjustment is necessary
2 -22	4.1.3 Print head position adjustment
2 -24	4.1.4 Print head seam stripe adjustment (<u>S750</u>)
2 -25	4.1.5 Grease Application

Page	
2 -26	4.2 Confirmation method
2 -27	5. TRANSPORTING THE PRINTER
2 -27	5.1 Procedure
2 -28	6. PARTS REPLACEMENT, PERIODIC INSPECTIONS, & TOOLS
2 -28	6.1 Periodic Parts Replacement
2 -28	6.2 Periodic Inspections
2 -28	6.3 Tool List
2 -29	7. SERVICE-RELATED FEATURES
2 -29	7.1 Service Mode Operations
2 -30	7.2 Test Printout
2 -32	7.3 Printing the EEPROM Information
2 -34	7.4 Resetting the EEPROM
2 -34	7.5 Waste Ink counter settings (<u>S900/S820</u>)

Part 3: TECHNICAL REFERENCE

3 - 1	1. NEW TECHNOLOGY
3 - 1	1.1 Borderless printing
	1.1.1 Borderless printing limitations
3 - 2	1.2 Quiet Mode
3 - 2	1.2.1 Quiet mode limitations
3 - 2	1.3 Remaining-ink amount detection (<u>S900/S820</u>)
3 - 2	1.3.1 Limitations when using the remaining-ink amount detection function
3 - 3	2. CLEANING MODES AND INK PURGE AMOUNTS
3 - 5	3. PRINT MODES

Part 4: APPENDIX

(S900)

4 - 1	1. CONNECTOR LOCATIONS AND PIN CONFIGURATIONS
4 - 1	1.1 Logic Board
4 - 4	1.2 Carriage Board
4 - 5	1.3 Print Head

(S820)

4 - 6	1. CONNECTOR LOCATIONS AND PIN CONFIGURATIONS
4 - 6	1.1 Logic Board
4 - 9	1.2 Carriage Board
4 -10	1.3 Print Head

(S750)

4 -11	1. CONNECTOR LOCATIONS AND PIN CONFIGURATIONS
4 -11	1.1 Logic Board
4 -14	1.2 Carriage Board
4 -15	1.3 Print Head

(S520)

4 -16	1. CONNECTOR LOCATIONS AND PIN CONFIGURATIONS
4 -16	1.1 Logic Board
4 -19	1.2 Carriage Board
4 -20	1.3 Print Head
4 -21	2.PROBLEMS LEFT REMAINING

III. ILLUSTRATION INDEX

	Part 1: PRODUCT SPECIFICATIONS	
	(S900)	
1 - 1	Figure 1 - 1	Printer Exterior (S900)
1 - 3	Figure 1 - 2	JEIDA Standard Pattern
1 - 3	Figure 1 - 3	JIS SCID No. 5
1 - 5	Figure 1 - 4	Printable Area
	(S820)	
1 - 9	Figure 1 - 5	Printer Exterior (S820)
1 -12	Figure 1 - 6	Printable Area
	(S750)	
1 -15	Figure 1 - 7	Printer Exterior (S750)
1 -18	Figure 1 - 8	Printable Area
	(S520)	
1 -21	Figure 1 - 9	Printer Exterior (S520)
	Part 2: TROUBLESHOOTING	
2 - 1	Figure 2 - 1	Operation Panel
2 - 3	Figure 2 - 2	Nozzle Check Pattern Printout
2 -14	Figure 2 - 3	Exploded View
2 -15	Figure 2 - 4	Carriage Lock Release
2 -16	Figure 2 - 5	Timing Slit Strip
2 -17	Figure 2 - 6	Short-Circuiting the Capacitors
2 -18	Figure 2 - 7	Do not Remove the Red Screws
2 -18	Figure 2 - 8	Installing the Logic Board Cover
2 -19	Figure 2 - 9	Installing the ROM Cover
2 -22	Figure 2 -10	Print Position Alignment Pattern
2 -24	Figure 2 -11	Seam Stripe Adjustment Pattern
2 -25	Figure 2 -12	Grease application
2 -30	Figure 2 -13	Service/Factory Test Printout (Sample)
2 -32	Figure 2 -14	EEPROM Information Printout (Sample)
	Part 3: TECHNICAL REFERENCE	
3 - 2	Figure 3 - 1	Remaining Ink amount detection
	Part 4: APPENDIX	
	(S900)	
4 - 1	Figure 4 - 1	Logic Board
4 - 4	Figure 4 - 2	Carriage Board
4 - 6	Figure 4 - 3	Print Head
	(S820)	
4 - 6	Figure 4 - 4	Logic Board
4 - 9	Figure 4 - 5	Carriage Board
4 -10	Figure 4 - 6	Print Head
	(S750)	
4 -11	Figure 4 - 7	Logic Board
4 -14	Figure 4 - 8	Carriage Board
4 -15	Figure 4 - 9	Print Head
	(S520)	
4 -16	Figure 4 -10	Logic Board
4 -19	Figure 4 -11	Carriage Board
4 -20	Figure 4 -12	Print Head

IV. TABLE INDEX

Page	<i>Part 1: PRODUCT SPECIFICATIONS</i>		
	(S900)		
1 - 7	Table 1- 1	PRODUCT CODE LIST	
	(S820)		
1 -14	Table 1- 2	PRODUCT CODE LIST	
	(S750)		
1 -20	Table 1- 3	PRODUCT CODE LIST	
	(S520)		
1 -24	Table 1- 4	PRODUCT CODE LIST	
	<i>Part 2: TROUBLESHOOTING</i>		
2 -10	Table 2- 1	ERROR INDICATIONS	
2 -21	Table 2- 2	EEPROM SETTINGS WHEN REPLACING THE INK ABSORBER	
	<i>Part 3: TECHNICAL REFERENCE</i>		
3 - 3	Table 3 - 1	CLEANING MODES	
3 - 5	Table 3 - 2	PRINT MODES	



Part 1

PRODUCT SPECIFICATIONS

Page		Page	
	(S900)		(S750)
1 - 1	1. PRODUCT OVERVIEW	1 -15	1. PRODUCT OVERVIEW
1 - 1	1.1 Product Overview	1 -15	1.1 Product Overview
1 - 1	1.2 Special Features	1 -15	1.2 Special Features
1 - 2	2. SPECIFICATIONS	1 -16	2. SPECIFICATIONS
1 - 2	2.1 Printer Specifications	1 -16	2.1 Printer Specifications
1 - 4	2.2 Paper Specifications	1 -18	2.2 Paper Specifications
1 - 6	2.3 Print Head Specifications	1 -19	2.3 Print Head Specifications
1 - 6	2.4 Printer and Scanner Drivers	1 -19	2.4 Printer and Scanner Drivers
1 - 7	3. PRODUCT CODE LIST	1 -20	3. PRODUCT CODE LIST
	(S820)		(S520)
1 - 9	1. PRODUCT OVERVIEW	1 -21	1. PRODUCT OVERVIEW
1 - 9	1.1 Product Overview	1 -21	1.1 Product Overview
1 - 9	1.2 Special Features	1 -21	1.2 Special Features
1 -10	2. SPECIFICATIONS	1 -22	2. SPECIFICATIONS
1 -10	2.1 Printer Specifications	1 -22	2.1 Printer Specifications
1 -12	2.2 Paper Specifications	1 -23	2.2 Paper Specifications
1 -13	2.3 Print Head Specifications	1 -23	2.3 Print Head Specifications
1 -13	2.4 Printer and Scanner Drivers	1 -23	2.4 Printer and Scanner Drivers
1 -14	3. PRODUCT CODE LIST	1 -24	3. PRODUCT CODE LIST

I. PRODUCT OVERVIEW

1.1 Product Overview

"High Speed, Ultra-fine Image Photo Printer"

With a new head (512 nozzles x 6 colors, 1200dpi resolution) and improvements to the printer driver, this printer realizes the highest photo printing speed in its class and the finest picture quality among its competitors.

The printer is targeted at amateur users as well as high-end design and photography professionals who need realistic photo-quality output from their digital cameras, scanners, etc.

1.2 Special Features

(1) Speed

The new head (512 nozzles x 6 colors, 1200 dpi resolution) allows improved print speed (1 ppm photo printing).

(2) Image Quality

Increased color range and half toning due to advanced image management.

(3) Servicing

Servicing is almost identical to that of the S600.

(4) Value Added Features

Total borderless printing (for postcard, A4, LTR, L-size, 2L-size, 4" x 6")

A new level of quietness with the adoption of Quiet mode.

(5) Other

Paper feed strength has been greatly improved by use of the S600 ASF.

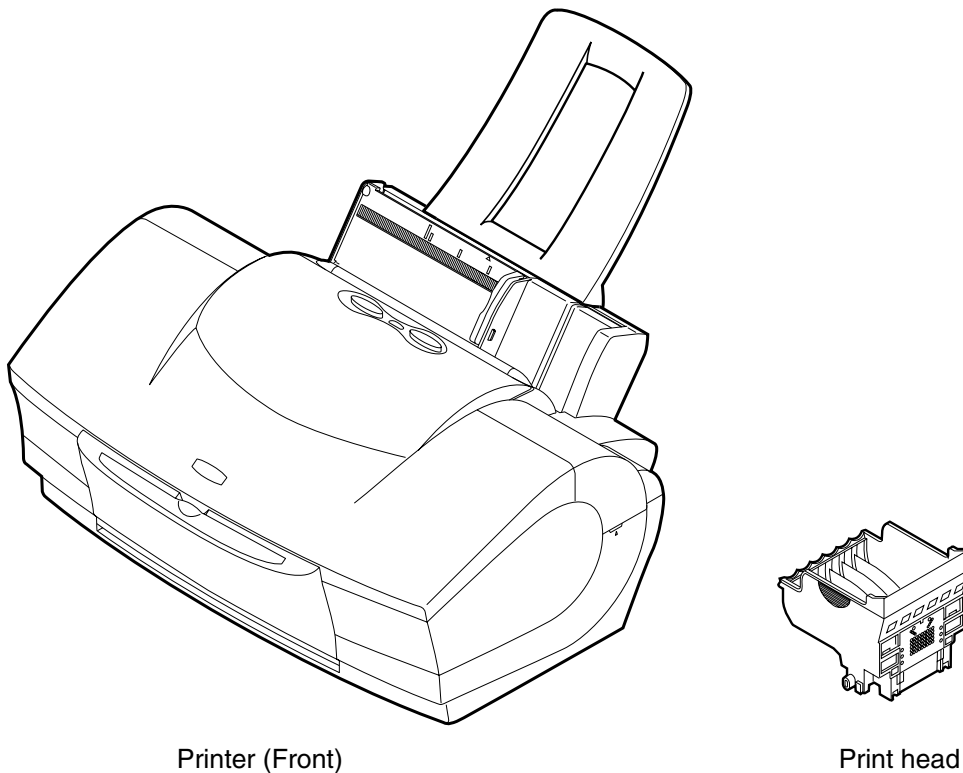

Printer (Front)

Print head

Figure 1-1 Printer Exterior (S900)

2. SPECIFICATIONS

2.1 Printer Specifications

2.1.1 Printer specifications

Type	Desktop serial printer		
Paper Feed System	Automatic feed only (No manual feed)		
Resolution	2400 × 1200 dpi (Max. resolution)		
Throughput		HS	HQ
	Bk (Fast Gear: J)	6.8-7.4	5.5-6.0
	Color (Fast Gear: J)	6.9-7.3	4.4-4.8
	Photo (ISO JIS-SCID NO.5)	0.94-1.07	0.49-0.55
Printing Direction	Bi-directional / Uni-directional (<i>See Part 3.3: PRINT MODE LIST</i> for details)		
Max. Printing Width	203 mm (216 mm when borderless printing)		
Line Feed Speed	127 mm/s		
Interface	USB (Rev. 1.1)		
ASF Capacity	Max. 10 mm (about 100 sheets of 75 g/m ² paper)		
Sensors	Front cover-open sensor Print head sensor Ink-out and remaining ink sensors (optical type and dot count) Paper-out sensor Waste-ink full sensor Internal temperature sensor		
Print Head Alignment	Available (even and odd nozzles of each color, bidirectional adjustment)		
Operating Noise (draft, standard, high)	47/47/40 dB(A) Sound pressure level conforms to ISO9296		
Ambient Conditions	During operation:	Temperature	5C-35C
		Relative Humidity	10%-90% (No condensation)
	During non-operation:	Temperature	0C-40C
		Relative Humidity	5%-95% (No condensation)
Power Source	Power voltage/frequency	Power consumption	During standby
	100-127 VAC 50/60 Hz	Max. approx. 22 W	Approx. 6 W (2W*1)
	220-240 VAC 50/60 Hz	Max. approx. 21 W	Approx. 6 W (2W*1)
External Dimensions	Approx. 440 mm (W) × 300 mm (D) × 180 mm (H)		
Weight	5.8 kg (Not including print head and options)		
Related Standards	EMR interference: VCCI, FCC, IC, CE Mark, Taiwan / Korea EMC, CCIB (China EMC), C-tick Electrical safety: Dentori, UL, C-UL, CB Report, GS, CE Mark, FIMC, CCIB (electrical safety), AS, CCEE, PSB, Korean Dentori, SASO Environmental: Energy Star, Blue Angel, Environment label		
Serial No. Location	Carriage ribbon cable holder (visible when the access cover is open)		

*1: In energy-saving mode

2.1.2 Printer service life

Whichever comes first:

- (1) A total of 10,000 pages printed at 7.5% duty per color.
- (2) 5 years of use.

2.1.3 Print head service life

(1) Service life

10,000 pages of color printing (7.5% duty pattern printing per color)

(2) Ink tank service life (printable pages per tank)

Monochrome (black) *1

BCI-6Bk: 640 pages (2.05%)

Color *2

BCI-6Bk: 990 pages (print duty: 0.83%)

BCI-6C: 860 pages (print duty: 1.01%)

BCI-6M: 790 pages (print duty: 1.56%)

BCI-6Y: 470 pages (print duty: 2.70%)

BCI-6PC: 410 pages (print duty: 2.93%)

BCI-6PM: 270 pages (print duty: 4.95%)

*1: JEIDA Standard pattern (default driver setting)

*2: JIS SCID NO. 5 Pattern (measured when driver set to HQ photo printing on plain paper)

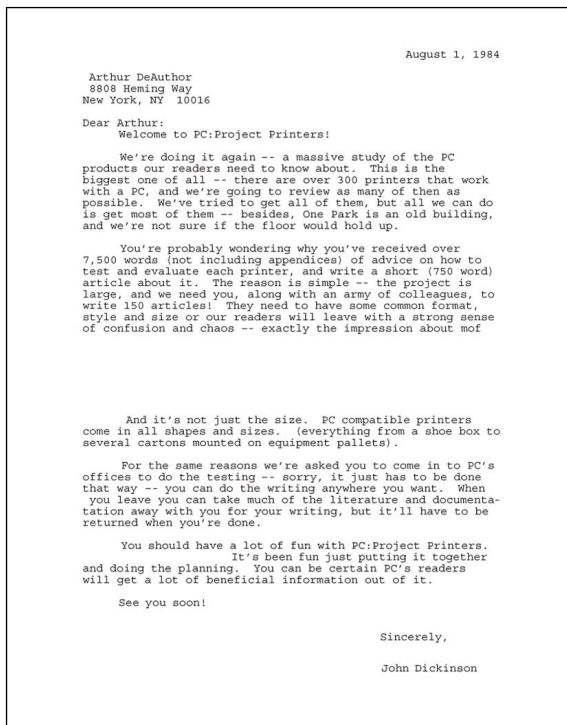

Figure 1-2 JEIDA Standard Pattern



Figure 1-3 JIS SCID No. 5

2.2 Paper Specifications

2.2.1 Paper sizes and weights

(1) Paper sizes

See the table below.

(2) Weight

For automatic feeding, the paper's weight should be 64-105 g/m².

2.2.2 Paper types and settings

Type		Size	Paper Feed Method	ASF Stacking Capacity
● Plain paper		A4/B5/A5/LTR/LGL	Auto	Less than 10 mm
High-quality paper	HR-101	A4/LTR	Auto	Approx. 80 sheets
● Photo glossy paper	GP-301	A4/LTR	Auto	10 sheets
● Professional Photo paper	PR-101	A4/LTR	Auto	1 sheet
	PR-101L	89 mm × 127 mm	Auto	20 sheets
	PR-101 2L	127 mm × 178 mm	Auto	10 sheets
	PR-101 4x6	101.6 mm × 152.4 mm	Auto	20 sheets
Glossy photo film	HG-201	A4/LTR	Auto	1 sheet
Transparency	CF-102	A4/LTR	Auto	Less than 30 sheets
Banner paper	--	A4/LTR	Auto	1 sheet
T-shirt transfer	TR-201	A4/LTR	Auto	1 sheet
Mouse pad	MK-101	---	Auto	1 sheet
● Glossy postcard	KH-201	148 mm × 100 mm	Auto	Less than 20 sheets
Photo glossy postcard	FM-101	119 mm × 216 mm		Less than 20 sheets
● Japan Post Office postcard	---	100 mm × 148 mm	Auto	Less than 40 sheets
● Japan Post Office postcard for ink jet printing	---	100 mm × 148 mm	Auto	Less than 40 sheets
Professional photo postcard	PH-101	100 mm × 148 mm	Auto	Less than 20 sheets
Envelope	COM#10	105 mm × 241 mm	Auto	Less than 10 envelopes
	DL-size	110 mm × 220 mm	Auto	Less than 10 envelopes
	No. 4	105 mm × 235 mm	Auto	Less than 10 envelopes
	No. 6	98 mm × 190 mm	Auto	Less than 10 envelopes
Professional photo card	PC-101 L	101.6 mm × 190.5 mm	Auto	Less than 20 sheets
	PC-101 2L	183 mm × 210 mm	Auto	Less than 10 sheets
	PC-101 D	210 mm × 310 mm	Auto	Less than 10 sheets
	PC-101 W	210 mm × 310 mm	Auto	Less than 10 sheets
	PC101 S	119 mm × 216mm	Auto	Less than 20 sheets
	PC-101 C	Perforated phonecard size	Auto	Less than 20 sheets

●: Borderless printing is possible with this paper (plain paper, A4/LTR size only).

2.2.3 Printable area

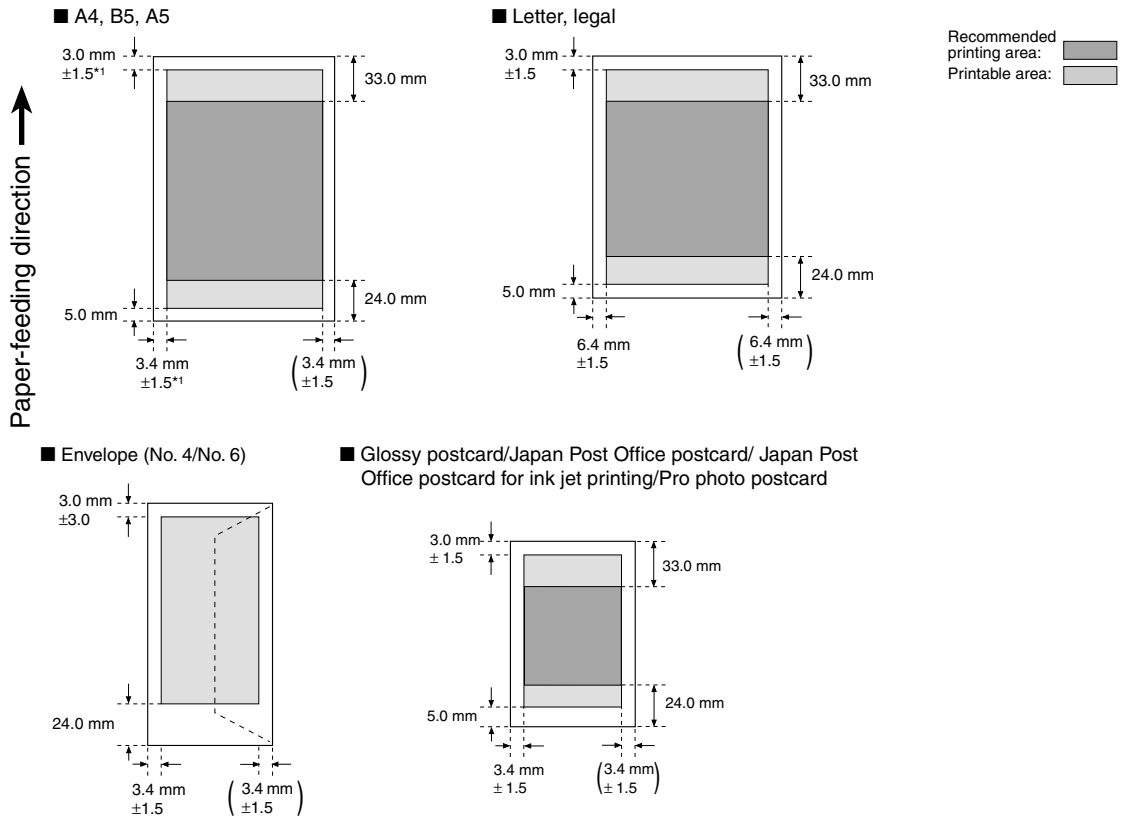

Product Specifications

*1 For recycled paper, 3.0 mm ±3 or 3.4 mm ±2.
 *2 If the bottom margin goes beyond the plain paper's printable area, the software application's specifications apply.
 The region inside the dotted lines is the printable area where print quality can be guaranteed.
 Note: The right margins in parentheses indicate that the dimension depends on the paper size.

Figure 1-4 Printable Area

2.3 Print Head Specifications

	Print Head
Configuration	6 color integrated head, detachable ink tanks for each color
Print Head	512 x 6 nozzles
Ink Colors	BCI-6Bk, C, M, Y, PC, PM
Ink Tank	6 separate ink tanks by color
Head Weight	Approx. 80 g (not including ink)
Ink Tank Weight (Net)	11 g
Supply method	Service parts (not including ink tanks)

2.4 Printer and Scanner Drivers

1. Windows drivers
 - Windows 98/98 S.E./Millennium printer drivers Ver. 7.20
 - Windows 2000 printer driver Ver. 1.50
 - Windows XP printer driver Ver. 1.50
2. Macintosh driver
 - Mac OS (inc. OS X) printer driver Ver. 3.90

3. PRODUCT CODE LIST

The table below lists the product codes of the printer, consumables and optional items.
The print head will be supplied only as a spare part for servicing.

Table 1-1 PRODUCT CODE LIST

Item		Designation	Product Code	Destination
Printer	---	Canon Bubble Jet Printer S900	6873A0XXAA	Substitute 'XX' with the following country codes 01: USA 02: CAN 03: Latin LV 04: Latin HV 05: EUR 06: GER 07: FRN 08: ASIA HV 09: AUST 10: KRN 11: UK 12: JPN 13: TW 14: HK 15: CHN
Print head* ¹	---	---	QY6-0039	
Ink tank		Canon Ink Tank		Substitute 'X' with the following country codes
	Black	BCI-6BK	4705A00XAA	1: JPN
	Cyan	BCI-6C	4706A00XAA	2: EUR
	Magenta	BCI-6M	4707A00XAA	3: AMR
	Yellow	BCI-6Y	4708A00XAA	4: ASIA/OCN
	PC	BCI-6PC Photo	4709A00XAA	
	PM	BCI-6PM Photo	4710A00XAA	

*1: Supplied strictly as a service part. Not supplied as a consumable or an optional item.

This page intentionally left blank

I. PRODUCT OVERVIEW

1.1 Product Overview

"Ultra-High Image Quality Photo Printer"

1.2 Special Features

(1) Image Quality

Increased color range and half toning due to advanced image management.

(2) Servicing

Servicing is almost identical to that of the S600.

(3) Value Added Features

Total borderless printing (for postcard, A4, LTR, L-size, 2L-size, 4" x 6")

A new level of quietness with the adoption of Quiet mode.

(4) Other

Paper feed strength has been greatly improved by use of the S600 ASF.

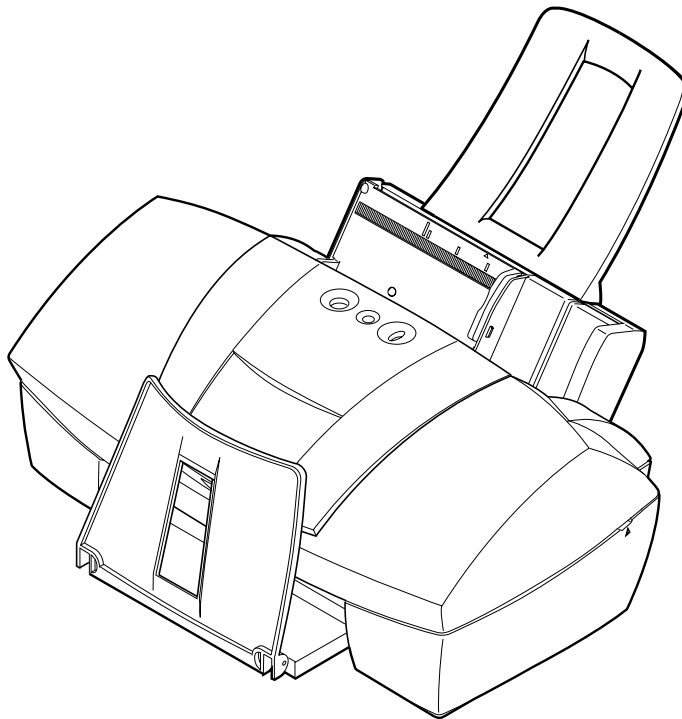

Printer (Front)

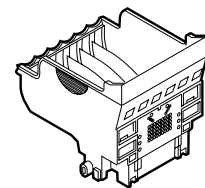

Print head

Figure 1-5 Printer Exterior (S820)

2. SPECIFICATIONS

2.1 Printer Specifications

2.1.1 Printer specifications

Type	Desktop serial printer			
Paper Feed System	Automatic feed only (No manual feed)			
Resolution	2400 × 1200 dpi (Max. resolution)			
Throughput		Draft	Standard	High
	Bk (Fast Gear: J)	4	3.4	1.1
	Color (Fast Gear: J)	4	1.9	0.8
	Photo (ISO JIS-SCID NO.5)	-	0.45	0.22
Printing Direction	Bi-directional / Uni-directional (<i>See Part 3.3. PRINT MODE LIST</i> for details)			
Max. Printing Width	203 mm (216 mm when borderless printing)			
Line Feed Speed	90 mm/s			
Interface	IEEE1394, USB (Rev.1.1)			
ASF Capacity	Max. 10 mm (about 100 sheets of 75 g/m ² paper)			
Sensors	Front cover-open sensor Print head sensor Ink-out and remaining ink sensors (optical type and dot count) Paper-out sensor Waste-ink full sensor Internal temperature sensor			
Print Head Alignment	Available (even and odd nozzles of each color, bidirectional adjustment)			
Operating Noise (draft, standard, high)	45/45/37 dB(A) Sound pressure level conforms to ISO9296			
Ambient Conditions	During operation:	Temperature	5C-35C	
		Relative Humidity	10%-90% (No condensation)	
	During non-operation:	Temperature	0C-40C	
		Relative Humidity	5%-95% (No condensation)	
Power Source	Power voltage/frequency	Power consumption	During standby	
	100-127 VAC 50/60 Hz	Max. approx. 22 W	Approx. 5 W (2W*1)	
	220-240 VAC 50/60 Hz	Max. approx. 21 W	Approx. 5 W (2W*1)	
External Dimensions	Approx. 430 mm (W) x 294 mm (D) x 177 mm (H)			
Weight	5.0 kg (Not including print head and options)			
Related Standards	EMR interference: VCCI, FCC, IC, CE Mark, Taiwan / Korea EMC, CCIB (China EMC), C-tick, CCEE Electrical safety: Dentori, UL, C-UL, CB Report, GS, CE Mark, FIMC, CCIB (electrical safety), AS, CCEE, PSB, Korean Dentori, SASO Environmental: Energy Star, Blue Angel, Environment label			
Serial No. Location	Carriage ribbon cable holder (visible when the access cover is open)			

*1: In energy-saving mode

2.1.2 Printer service life

Whichever comes first:

- (1) A total of 10,000 pages printed at 7.5% duty per color.
- (2) 5 years of use.

2.1.3 Print head service life

(1) Service life

5,000 pages of color printing (7.5% duty pattern printing per color)

(2) Ink tank service life (printable pages per tank)

Monochrome (black) *¹

BCI-6Bk: 650 pages (2.05%)

Color *²

BCI-6Bk: 1150 pages (print duty: 0.83%)

BCI-6C: 980 pages (print duty: 1.01%)

BCI-6M: 740 pages (print duty: 1.56%)

BCI-6Y: 480 pages (print duty: 2.70%)

BCI-6PC: 430 pages (print duty: 2.93%)

BCI-6PM: 280 pages (print duty: 4.95%)

*1: JEIDA Standard pattern (default driver setting)

*2: JIS SCID NO. 5 Pattern (measured when driver set to HQ photo printing on plain paper). [Refer to page 1-3 for this print pattern.](#)

2.2 Paper Specifications

2.2.1 Paper sizes and weights

See table for S900

2.2.2 Paper types and settings

See table for S900

2.2.3 Printable area

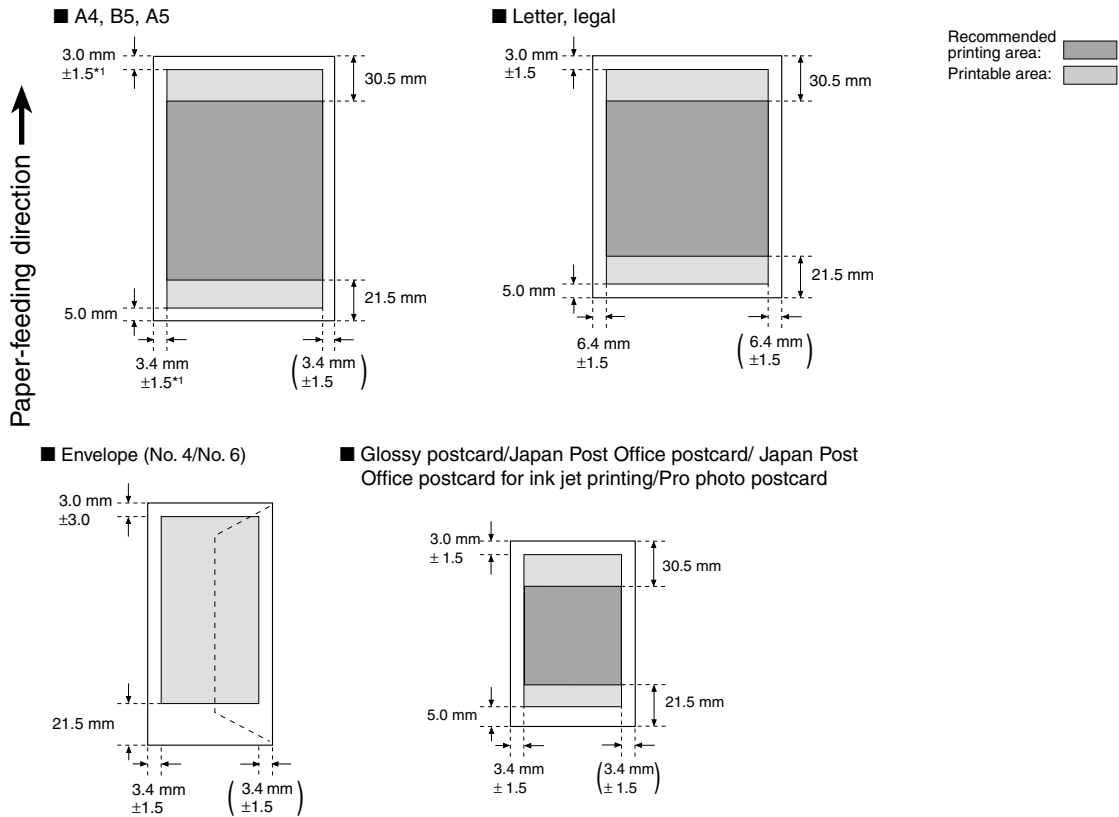

*1 For recycled paper, 3.0 mm ±3 or 3.4 mm ±2.

*2 If the bottom margin goes beyond the plain paper's printable area, the software application's specifications apply.

The region inside the dotted lines is the printable area where print quality can be guaranteed.

Note: The right margins in parentheses indicate that the dimension depends on the paper size.

Figure 1-6 Printable Area

2.3 Print Head Specifications

	Print Head
Configuration	6 color integrated head, detachable ink tanks for each color
Print Head	256 x 6 nozzles
Ink Colors	BCI-6Bk, C, M, Y, PC, PM
Ink Tank	6 separate ink tanks by color
Head Weight	Approx. 80 g (not including ink)
Ink Tank Weight (Net)	11 g
Supply method	Service parts (not including ink tanks)

2.4 Printer and Scanner Drivers

1. Windows drivers

Windows 95/98/98 S.E./Millennium printer drivers (IEEE1284/USB) *1 Ver. 7.20

Windows NT 4.0 (IEEE1284) Ver. 4.50

Windows 2000 printer driver (IEEE1284/USB) Ver. 1.50

Windows XP printer driver (IEEE1284/USB) Ver. 1.50

2. Macintosh driver

Mac OS (inc. OS X) printer driver (USB) Ver. 3.90

*1: Windows 95 supports only IEEE1284

3. PRODUCT CODE LIST

The table below lists the product codes of the printer, consumables and optional items. The print head will be supplied only as a spare part for servicing.

Table 1-2 PRODUCT CODE LIST

Item		Designation	Product Code	Destination
Printer	---	Canon Bubble Jet Printer S820	6859A0XXAA	Substitute 'XX' with the following country codes 01: USA 02: CAN 03: Latin LV 04: Latin HV 05: EUR 06: GER 07: FRN 08: ASIA HV 09: AUST 10: KRN 11: UK 12: JPN 13: TW 14: HK 15: CHN
Print head* ¹	---	---	QY6-0040	
Ink tank		Canon Ink Tank		Substitute 'X' with the following country codes
	Black	BCI-6BK	4705A00XAA	
	Cyan	BCI-6C	4706A00XAA	1: JPN
	Magenta	BCI-6M	4707A00XAA	2: EUR
	Yellow	BCI-6Y	4708A00XAA	3: AMR
	PC	BCI-6PC Photo	4709A00XAA	4: ASIA/OCN
	PM	BCI-6PM Photo	4710A00XAA	

*1: Supplied strictly as a service part. Not supplied as a consumable or an optional item.

I. PRODUCT OVERVIEW

1.1 Product Overview

"High-Performance Next Generation Printer"

This is a personal ink-jet printer to match the speed and features of printers for the business market, taking full advantage of speed technology developed for the S600/S630 series.

1.2 Special Features

Speed	Highest quality, highest speed with bidirectional 1200dpi nozzle pitch head. Monochrome text (HS): 20 ppm * ¹ Color DTP (HS): 13 ppm * ² Color full address: 1.5 ppm * ³
Image quality	Image quality improvements through use of new print head. Print head improvements (staggering of black & color nozzles) allow resolution of uneven density due to time lag in bidirectional printing.
Service	Servicing is almost identical to that of the S600, since major mechanical parts (sheet feeder unit, purge unit, carriage unit) and mechanical structure are very similar. Consumables (ink tanks) are same as for the S600/S630.
Value Added Features	The borderless printing feature has been added for supported paper types.* ⁴ The Quiet mode feature has been added.
Other	Double-sided printing has been made possible.* ⁵

*1: Measured using the FAST GEAR (Black) pattern introduced in 2000.

*2: Measured using the FAST GEAR (Color) pattern introduced in 2000.

*3: Measured using the A4 Full Pattern (A4 page, 1200 x 1200 dpi, dot-by-dot print pattern).

*4: Paper types created specially to take advantage of the borderless printing feature.

*5: With this double sided printing feature, the printer will feed the paper again after printing one side, in order to print the remaining surface. This feature has been added to comply with the Green Procurement Policy (Japan).

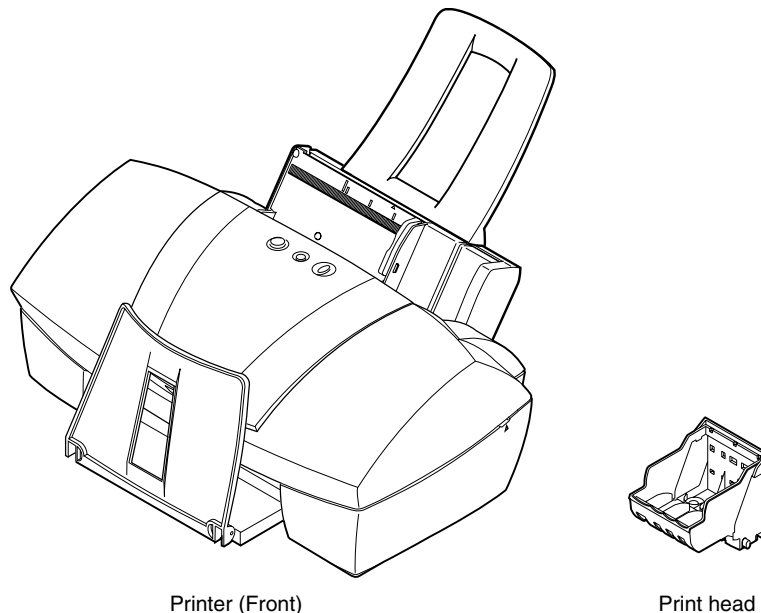

Printer (Front)

Print head

Figure 1-5 Printer Exterior (S750)

Product Specifications

2. SPECIFICATIONS

2.1 Printer Specifications

2.1.1 Printer specifications

Type	Desktop serial printer			
Paper Feed System	Automatic feed only (No manual feed)			
Resolution	2400 × 1200 dpi (Max. resolution)			
Throughput		HS	HQ	
	Bk (Fast Gear: J)	20 ppm	12 ppm	
	Color (Fast Gear: J)	13 ppm	8 ppm	
Printing Direction	Bi-directional (<i>See Part 3:3. PRINT MODE LIST</i> for details)			
Max. Printing Width	203 mm (8 inches). 216 mm when borderless printing.			
Interface	IEEE1284 compatible 8-bit parallel, USB (no HUB function)			
ASF Capacity	Max. 10 mm (about 100 sheets of 75 g/m ² paper or 110 sheets of 64 g/m ² paper)			
Sensors	Front cover-open sensor, Print head sensor , Ink-out sensor Print position sensor, Paper-out sensor (paper rear edge sensor) Waste-ink quantity sensor, Internal temperature sensor Pickup roller sensor, Paper feed roller position sensor Carriage position sensor, Paper thickness lever sensor			
Operating Noise (draft, standard, high)	51/51/45 dB(A) Sound pressure level conforms to ISO9296			
Ambient Conditions	During operation:	Temperature	5C-35C	
		Relative Humidity	10%-90% (No condensation)	
	During non-operation:	Temperature	0C-40C	
		Relative Humidity	5%-95% (No condensation)	
Power Source	Power voltage/frequency	Power consumption	During standby	off
	100-127 VAC 50/60 Hz	Max. approx. 33 W	Approx. 3 W	Approx. 1 W
	220-240 VAC 50/60 Hz	Max. approx. 33 W	Approx. 3 W	Approx. 1 W
External Dimensions	Approx. 430 mm (W) x 294 mm (D) x 177 mm (H)			
Weight	5.0 kg (Not including print head)			
Related Standards	EMR interference: VCCI, FCC, IC, C-tick, Taiwan / Korea EMC, CCIB (EMC)/CCEE, Gost-R Electrical safety: Dentori, UL, C-UL, CE Mark, TUV, FIMKO, SASO, AS, PSB, Korean Dentori, CB/CCIB/CCEE Environmental: Energy Star, Blue Angel			
Serial No. Location	Carriage ribbon cable holder (visible when the access cover is open)			

2.1.2 Printer service life

Whichever comes first:

- (1) A total of 30,000 pages (1500 standard characters in black ink)
- (2) A total of 10, 000 pages (printed at 7.5% duty per color)
- (3) 5 years of use

2.1.3 Print head service life

(1) Service life

A total of 30,000 pages (1500 standard characters in black ink)

A total of 10,000 pages (printed at 7.5% duty per color)

(2) Ink tank service life (printable pages per tank)

Monochrome (black): 775 pages (JEIDA Standard pattern J1*¹ / Standard quality)

Color (cyan): 600 pages (JIS SCID No. 5*² / Standard quality)

(magenta): 480 pages (as above)

(yellow): 390 pages (as above)

(black): 1200 pages (as above)

*1: Print duty: 1.97% pattern equivalent

*2: Print duty: 3.16% (cyan) equivalent

: 4.16% (magenta) equivalent

: 5.94% (yellow) equivalent

[Refer to page 1-3 for print patterns.](#)

2.2 Paper Specifications

2.2.1 Paper sizes and weights

See table for S900

2.2.2 Paper types and settings

See table for S900

2.2.3 Printable area

Choosing total area borderless printing allows printing without margins.

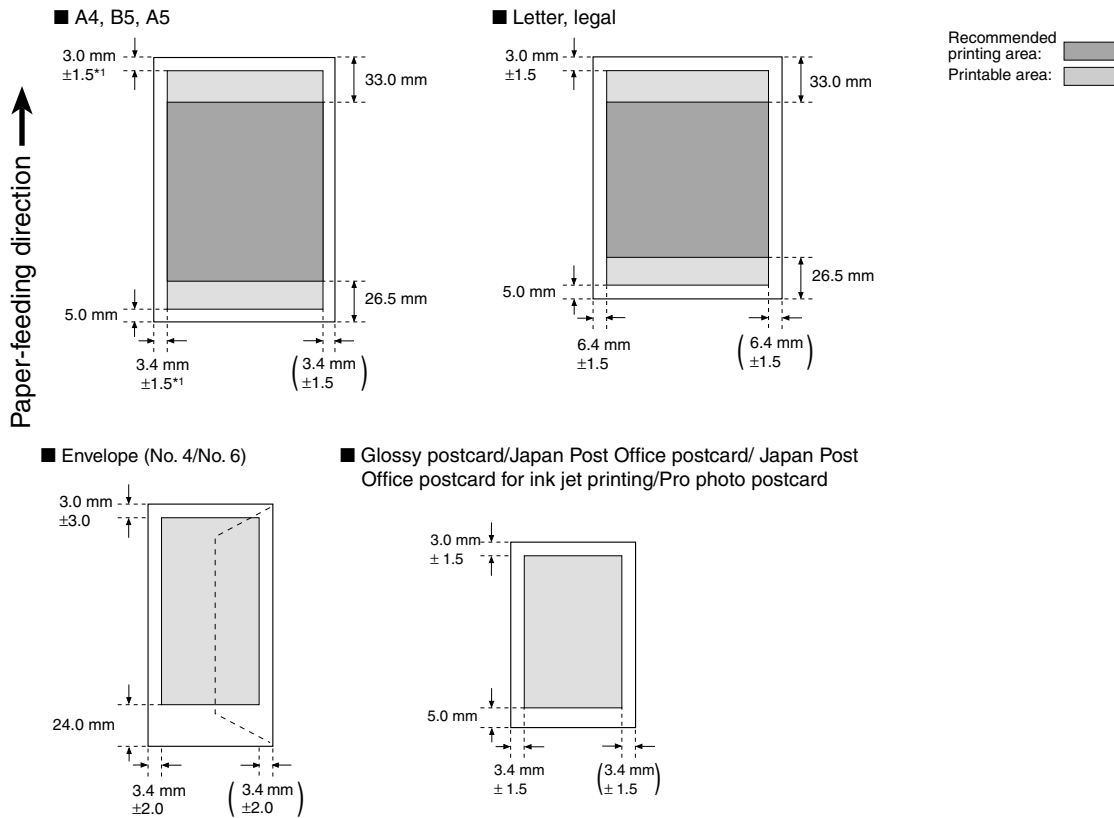

*1 For recycled paper, 3.0 mm ±3 or 3.4 mm ±2.

*2 If the bottom margin goes beyond the plain paper's printable area, the software application's specifications apply.

The region inside the dotted lines is the printable area where print quality can be guaranteed.

Note: The right margins in parentheses indicate that the dimension depends on the paper size.

Figure 1-8 Printable Area

2.3 Print Head Specifications

	Print Head
Configuration	Integrated head, detachable ink tanks for black and color (C, M, Y)
Print Head	Black: 320 nozzles in 2 vertical columns Color: 256 nozzles in 2 vertical columns per color
Ink Colors	Pigment Bk, Dye C, M, Y
Ink Tank	BC-3eBk, BCI-3eC, BCI-3eM, BCI-3eY
Ink Tank Weight (Net)	Black: 32 g Color (C, M, Y): 11 g
Supply method	Service parts (not including ink tanks)

2.4 Printer and Scanner Drivers

1 Windows drivers

Windows 95/98/98 S.E./Millennium printer drivers (IEEE1284/USB) *1 Ver. 7.20

Windows NT 4.0 (IEEE1284) Ver. 4.50

Windows 2000 printer driver (IEEE1284/USB) Ver. 1.50

Windows XP printer driver (IEEE1284/USB) Ver. 1.50

4 Macintosh driver

Mac OS (inc. OS X) printer driver (USB) Ver. 3.90

*1: Windows 95 supports only IEEE1284

3. PRODUCT CODE LIST

The table below lists the product codes of the printer, consumables and optional items. The print head will be supplied only as a spare part for servicing.

Table 1-3 PRODUCT CODE LIST

Item		Designation	Product Code	Destination
Printer	---	Canon Bubble Jet Printer S750	7290A0XXAA	Substitute 'XX' with the following country codes 01: USA 02: CAN 03: Latin LV 04: Latin HV 05: EUR 06: GER 07: FRN 08: ASIA HV 09: AUST 10: KRN 11: UK 12: JPN 13: TW 14: HK 15: CHN
Print head*1	---	---	QY6-0041	
Ink tank		Canon Ink Tank		Substitute 'X' with the following country codes
	Black	BCI-3eBK	4479A00XAA	1: JPN
	Cyan	BCI-3eC	4480A00XAA	2: EUR
	Magenta	BCI-3eM	4481A00XAA	3: AMR
	Yellow	BCI-3eY	4482A00XAA	4: ASIA/OCN

*1: Supplied strictly as a service part. Not supplied as a consumable or an optional item.

I. PRODUCT OVERVIEW

1.1 Product Overview

"Low-Cost, High-Performance Next Generation Printer"

This is a less expensive version of the high-performance S750, incorporating its next generation standard engine for high image quality.

1.2 Special Features

Speed	Highest quality, highest speed with bidirectional 1200 dpi nozzle pitch head. Monochrome text (HS): 14 ppm * ¹ Color DTP (HS): 9 ppm * ² Color full address: 1.1 ppm * ³
Image quality	Same as that of the S600/S630. The print head is already in current use.
Service	Servicing is almost identical to that of the S600, since major mechanical parts (sheet feeder unit, purge unit, carriage unit) and mechanical structure are very similar. Consumables (ink tanks) are same as for the S600/S630.
Value Added Features	The borderless printing feature has been added for supported paper types.* ⁴ The Quiet mode feature has been added.
Other	Double-sided printing has been made possible. * ⁵

*1: Measured using the FAST GEAR (Black) pattern introduced in 2000.

*2: Measured using the FAST GEAR (Color) pattern introduced in 2000.

*3: Measured using the A4 Full Pattern (A4 page, 1200 x 1200 dpi, dot-by-dot print pattern).

*4: Paper types created specially to take advantage of the borderless printing feature.

*5: With this double sided printing feature, the printer will feed the paper again after printing one side, in order to print the remaining surface. This feature has been added to comply with the Green Procurement Policy (Japan).

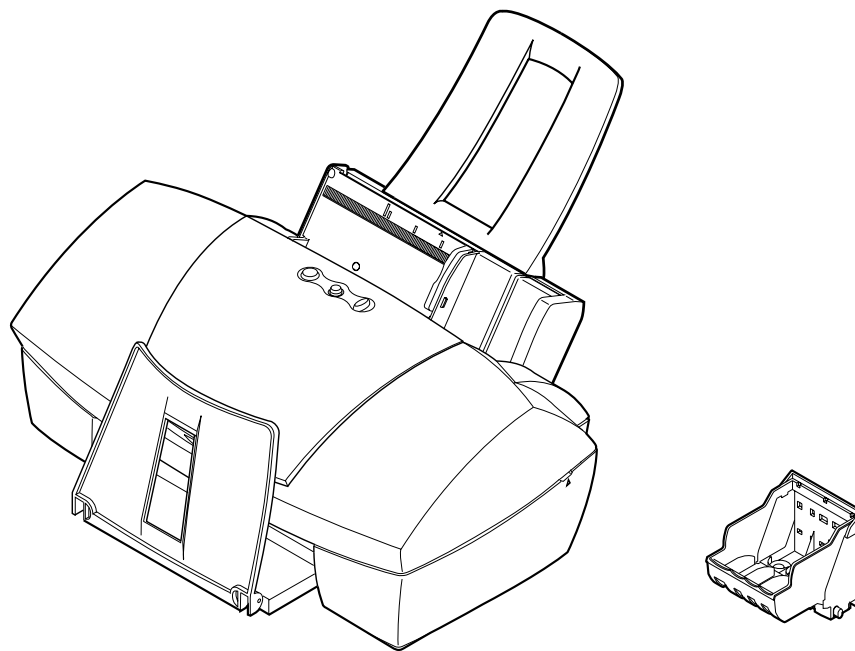

Printer (Front)

Print head

Figure 1-9 Printer Exterior (S520)

Product Specifications

2. SPECIFICATIONS

2.1 Printer Specifications

2.1.1 Printer specifications

Type	Desktop serial printer			
Paper Feed System	Automatic feed only (No manual feed)			
Resolution	2400 × 1200 dpi (Max. resolution)			
Throughput		HS	HQ	
	Bk (Fast Gear: J)	<u>14</u> ppm	<u>9</u> ppm	
	Color (Fast Gear: J)	<u>10</u> ppm	<u>6</u> ppm	
Printing Direction	Bi-directional (<i>See Part 3:3. RINT MODE LIST</i> for details)			
Max. Printing Width	203 mm (8 inches). 216 mm when borderless printing.			
Interface	IEEE1284 compatible 8-bit parallel, USB (no HUB function)			
ASF Capacity	Max. 10 mm (about 100 sheets of 75 g/m ² paper or 110 sheets of 64 g/m ² paper)			
Sensors	Front cover-open sensor, Print head sensor , Ink-out sensor Print position sensor, Paper-out sensor (paper rear edge sensor) Waste-ink quantity sensor, Internal temperature sensor Pickup roller sensor, Carriage position sensor Paper thickness lever sensor			
Operating Noise (draft, standard, high)	51/51/45 dB(A) Sound pressure level conforms to ISO9296			
Ambient Conditions	During operation:	Temperature	5C-35C	
		Relative Humidity	10%-90% (No condensation)	
	During non-operation:	Temperature	0C-40C	
		Relative Humidity	5%-95% (No condensation)	
Power Source	Power voltage/frequency	Power consumption	During standby	off
	100-127 VAC 50/60 Hz	Max. approx. 33 W	Approx. 3 W	Approx. 1 W
	220-240 VAC 50/60 Hz	Max. approx. 33 W	Approx. 3 W	Approx. 1 W
External Dimensions	Approx. 430 mm (W) x 294 mm (D) x 177 mm (H)			
Weight	5.0 kg (Not including print head)			
Related Standards	EMR interference: VCCI, FCC, IC, C-tick, Taiwan / Korea EMC, CCIB (EMC)/CCEE, Gost-R Electrical safety: Dentori, UL, C-UL, CE Mark, TUV, FIMKO, SASO, AS, PSB, Korean Dentori, CB/CCIB/CCEE Environmental: Energy Star, Blue Angel			
Serial No. Location	Carriage ribbon cable holder (visible when access cover is open)			

Underlined figures indicate difference from the S750.

2.1.2 Printer service life

Whichever comes first:

- (1) A total of 30,000 pages (1500 standard characters in black ink)
- (2) A total of 10, 000 pages (printed at 7.5% duty per color)
- (3) 5 years of use

2.1.3 Print head service life

(1) Service life

A total of 30,000 pages (1500 standard characters in black ink)

A total of 10,000 pages (printed at 7.5% duty per color)

(2) Ink tank service life (printable pages per tank)

Monochrome (black): 775 pages (JEIDA Standard pattern J1*¹ / Standard quality)

Color (cyan): 600 pages (JIS SCID No. 5*² / Standard quality)

(magenta): 480 pages (as above)

(yellow): 390 pages (as above)

(black): 1200 pages (as above)

*1: Print duty: 1.97% pattern equivalent

*2: Print duty: 3.16% (cyan) equivalent

: 4.16% (magenta) equivalent

: 5.94% (yellow) equivalent

[Refer to page 1-3 for print patterns.](#)

2.2 Paper Specifications

2.2.1 Paper sizes and weights

See table for S900

2.2.2 Paper types and settings

See table for S900

2.2.3 Printable area

See table for S750

2.3 Print Head Specifications

See table for S750

2.4 Printer and Scanner Drivers

See table for S750

3. PRODUCT CODE LIST

The table below lists the product codes of the printer, consumables and optional items. The print head will be supplied only as a spare part for servicing.

Table 1-4 PRODUCT CODE LIST

Item		Designation	Product Code	Destination
Printer	---	Canon Bubble Jet Printer S520	7100A0XXAA	Substitute 'XX' with the following country codes 01: USA 02: CAN 03: Latin LV 04: Latin HV 05: EUR 06: GER 07: FRN 08: ASIA HV 09: AUST 10: KRN 11: UK 12: JPN 13: TW 14: HK 15: CHN
Print head*1	---	---	QY6-0034	
Ink tank	Black Cyan Magenta Yellow	BCI-3eBK BCI-3eC BCI-3eM BCI-3eY	4479A00XAA 4480A00XAA 4481A00XAA 4482A00XAA	Substitute 'X' with the following country codes 1: JPN 2: EUR 3: AMR 4: ASIA/OCN

*1: Supplied strictly as a service part. Not supplied as a consumable or an optional item.



Part 2

TROUBLESHOOTING

Page	
2 - 1	1. PRINTER OPERATION
2 - 1	1.1 Printer Operation
2 - 1	1.2 Status Indicator
2 - 2	1.3 Simple Printer Operations
2 - 5	2. SERVICING
2 - 5	2.1 Before Troubleshooting
2 - 6	2.2 Detectable Problems from System Start to Exit
2 - 9	2.3 Troubleshooting Problems
2 -10	2.4 Troubleshooting Error Indications
2 -13	3. DISASSEMBLY AND REASSEMBLY
2 -13	3.1 Cautions for Disassembly and Reassembly
2 -14	3.2 Exploded View
2 -15	3.3 Disassembly and Reassembly
2 -20	4. ADJUSTMENTS AND SETTINGS AFTER DISASSEMBLY AND REASSEMBLY, AND CONFIRMATION OF OPERATION
2 -20	4.1 Adjustment and Settings after Disassembly and Reassembly
2 -26	4.2 Confirmation method
2 -27	5. TRANSPORTING THE PRINTER
2 -27	5.1 Procedure
2 -28	6. PARTS REPLACEMENT, PERIODIC INSPECTIONS, & TOOLS
2 -28	6.1 Periodic Parts Replacement
2 -28	6.2 Periodic Inspection
2 -28	6.3 Tool List
2 -29	7. SERVICE-RELATED FEATURES
2 -29	7.1 Service Mode Operations
2 -30	7.2 Test Printout
2 -32	7.3 Printing the EEPROM Information
2 -34	7.4 Resetting the EEPROM
2 -35	7.5 Waste-ink counter settings (<u>S900/S820</u>)

1. PRINTER OPERATION

You can operate the printer either by itself or with a computer. Both methods are explained below.

1.1 Printer Operation

The printer's operation panel has a *POWER* button and a *RESUME* button to cancel printing operation or to cancel an error. With a computer, you can use the printer driver to adjust the print head's position and to change various settings. For details on using the printer driver with the computer, see page 3-2

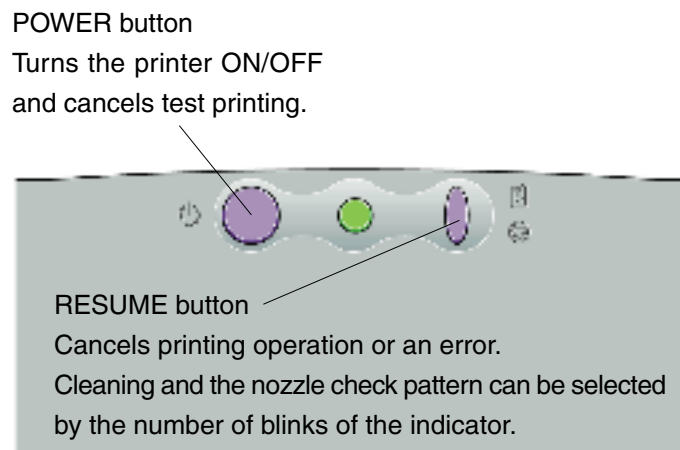

Figure 2-1 Operation Panel

1.2 Status Indicator

When you operate the printer by itself, you can find out the printer's status with the indicator. When an error occurs, the nature of the error can be determined by the number of times the indicator blinks.

Normal Operation

Indicator Display	Status
Green light	Power ON
Blinks green (Long/short)	Power ON in progress, power OFF in progress, resume operation in progress, cleaning in progress, test printing in progress, front cover open, printing in progress
Light off	Power OFF

Error

Indicator Display	Status
Blinks orange	The number of blinks differs depending on the error. See page 2-10 for details.
Green/orange (Toggle blinking)	The indicator blinks differently according to error. See page 2-11 for details.

1.3 Simple Printer Operations

The printer has an offline operation mode that works when the printer is not connected to a computer and the power is on.

To conduct the operations below, with the power turned on, hold down the **RESUME** button until the green indicator blinks the specified number of times.

Operation	Indicator Blink Count	Remarks
Cleaning operation	Once	---
Nozzle check pattern	Twice	Load a sheet of paper A4 size or larger
Roller cleaning operation	3 times	Load either no paper or A4
---	4 times	No function

1.3.1 Cleaning operation

To start the cleaning operation, turn on the printer and hold down the **RESUME** button until the green indicator blinks once. Cleaning will start when you let go of the button. This is the same as using the printer driver utility to perform cleaning. (The cleaning operation conducted is the same as using the S750/S520 driver utilities to clean all of the ink nozzles).

1.3.2 Printing the nozzle check pattern

With the printer turned on, hold down the **RESUME** button until the green indicator blinks twice. Let go and the printer will then start printing the nozzle check pattern. If any printing flaws show up in this test printout, perform print head cleaning.



Use A4/LTR size paper when printing the nozzle check pattern. If the paper's width is narrower than the nozzle check pattern, the printer will print on the bare platen, dirtying it with ink.



To stop printing of the test pattern midway, press the **POWER** button. Printing will stop and the paper will be ejected. The printer will remain on.



If the problem persists even after conducting cleaning three times, perform Deep Cleaning from the driver utilities. If that still does not resolve the problem, replace the print head.

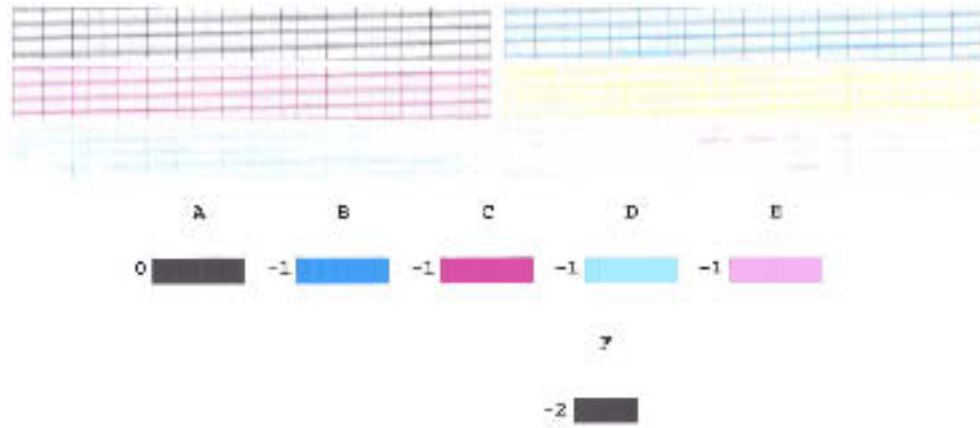

Figure 2-2 Nozzle Check Pattern Printout (S900)

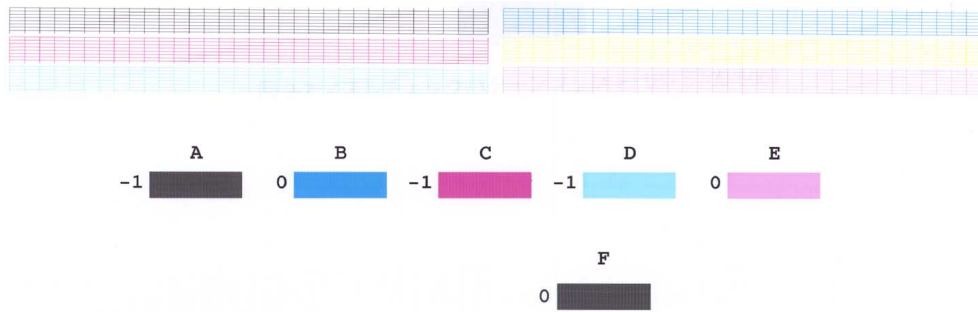

Figure 2-2 Nozzle Check Pattern Printout (S820)

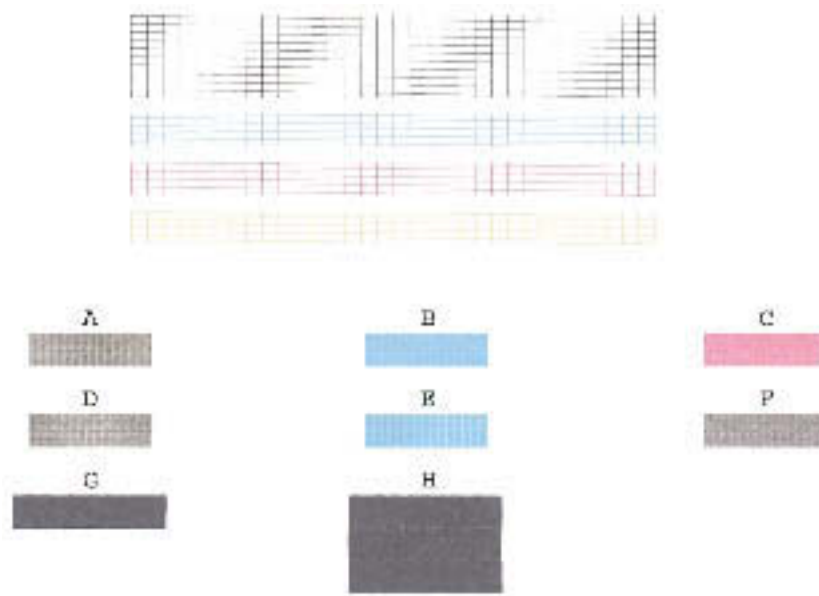

Figure 2-2 Nozzle Check Pattern Printout (S750/S520)

Troubleshooting

1.3.3 Roller cleaning operation

This is to remove the paper dust adhering to the auto sheet feeder's rollers. With the printer turned on, hold down the *RESUME* button until the green indicator blinks three times. The cleaning of the rollers will then start.

There are two cleaning methods:

(1) Using plain paper

Place a sheet of plain paper on the auto sheet feeder and execute roller cleaning.

Do this three times.

(2) Rotating the rollers without paper

Execute roller cleaning without placing any paper on the auto sheet feeder.

(The rollers will perform ten rotations.)

Do this three times.



Do not execute the cleaning operation more times than necessary.
Excessive cleaning will generate rubber dust which can affect the printer's operation.

2. SERVICING

2.1 Before Troubleshooting

Before troubleshooting, check the following and see if any of the problems you are experiencing can be fixed.

Problem	Probable Cause	Solution
The printer does not operate at all.	The power outlet is not supplying the required voltage.	Connect the AC cord to a power outlet which supplies the required voltage.
	The power cord is not properly connected to the printer or power outlet.	Check that the power cord is connected properly.
	An internal plug is disconnected.	Disconnect and reconnect the plug.
Paper feeding does not work.	Recommended paper is not being used.	Use only recommended paper.
	There is foreign matter in the paper feed section (sheet feeder, pinch roller, LF roller, platen, spurs).	Remove the foreign matter.
Printing does not take place	The Print Head needs cleaning.	Clean the Print Head.
	The ink cartridge is empty.	Replace the ink cartridge.
	The Print Head has not been used for a prolonged period.	Replace the cartridge, if the problem still persists after cleaning.
Stripes appear in the printout	The ink tanks are not properly seated.	Make sure the ink tanks are properly seated.
	Print head alignment has not been performed.	Perform print head alignment. (See page 2-22)
Color tones are incorrect	The ink tanks are not properly seated, cleaning has not been performed.	Make sure the ink tanks are properly seated, perform cleaning

2.2 Detectable Problems from System Start to Exit

Errors unresolvable by the user can be checked before system startup is completed.

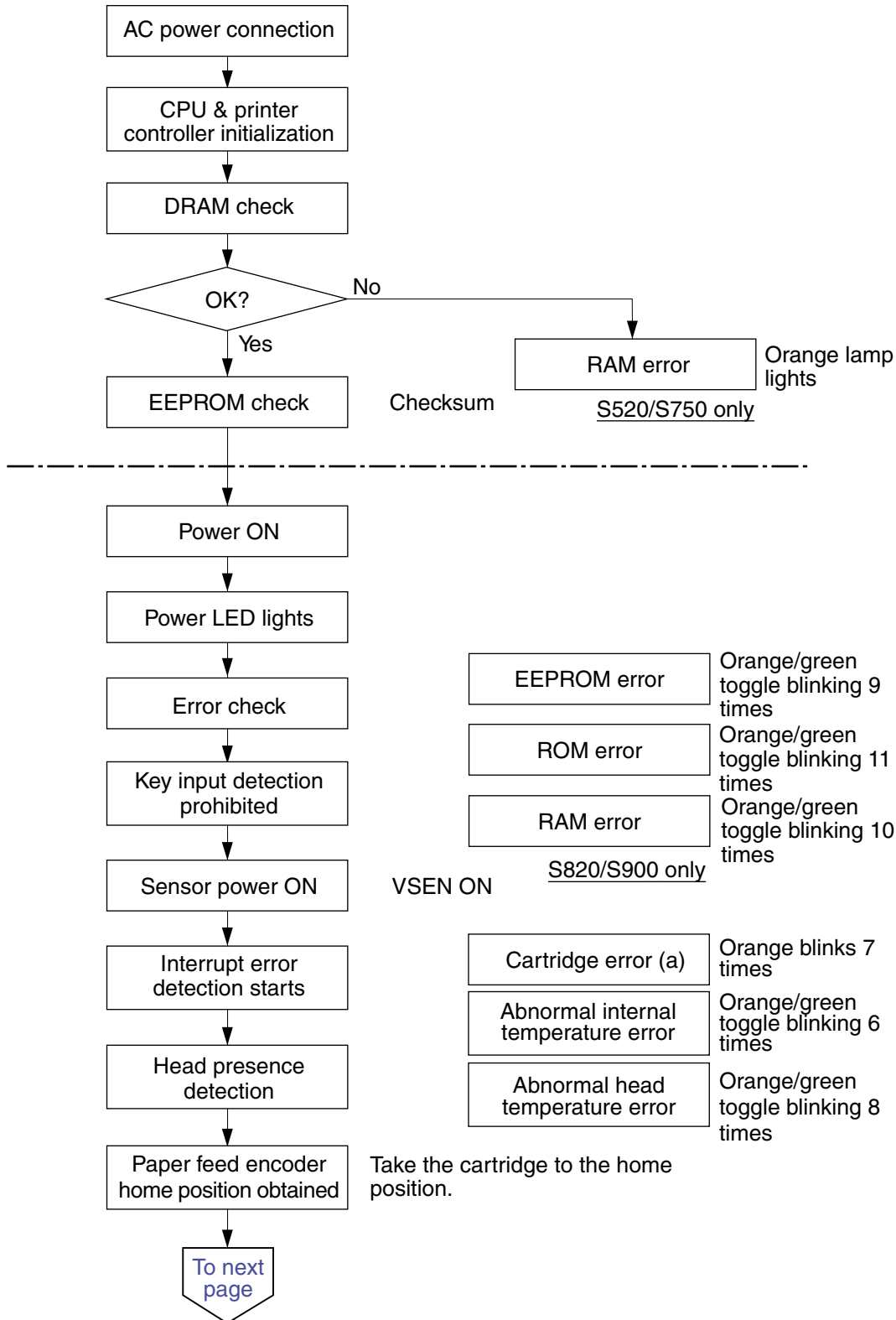

Troubleshooting

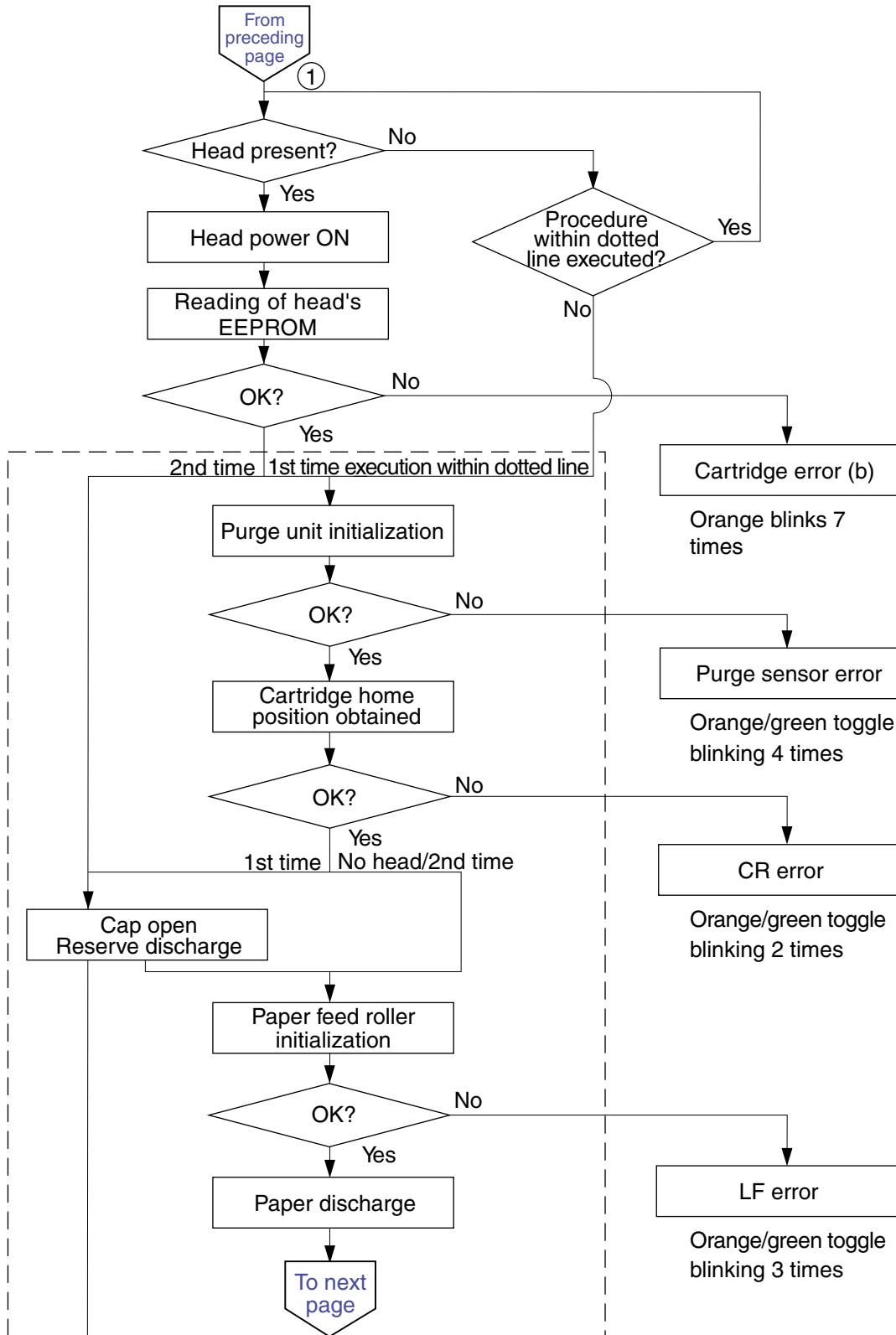

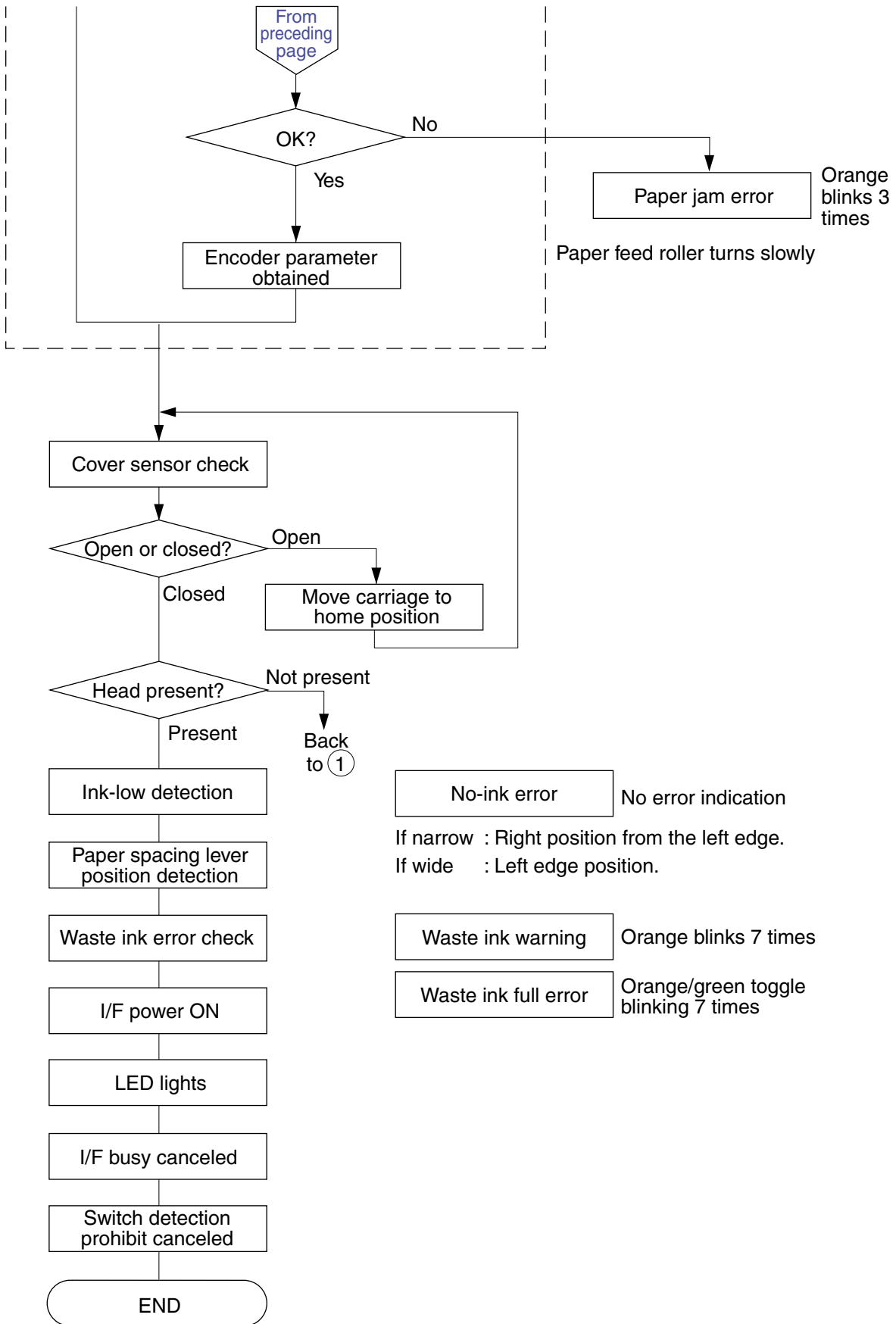

2.3 Troubleshooting Problems

	Problem	Probable Cause / Check Items	Solution
Faulty Operation	Power does not turn on. After power ON, it immediately turns off again.	1. AC adapter, 2. Logic board	1. Replace faulty parts.
	The print head is not recognized. It does not return to the home position.	1. Print head, 2. Print head contacts, 3. Carriage flex cable	1. Remove and reinstall print head / check the contacts, 2. Replace faulty parts.
	Abnormal noise	1. Dislodged parts, 2. Dislodged pinch roller	1. Remove foreign matter, 2. Reinstall dislodged parts
	Printing stops midway.	1. Logic board	1. Replace faulty parts.
Faulty Paper Feed	Multiple sheets are fed at a time.	1. ASF (Return tab, faulty pressure roller operation)	1. Replace faulty parts.
	Paper is not fed.	1. Foreign matter, 3. PE sensor arm	1. Remove foreign matter, 2. Replace faulty parts, 3. Replace ASF unit
	Paper is fed skewed.	1. Paper guide, 2. Foreign matter adhering to paper feed rollers	1. Adjust the paper guide to the correct position, 2. Remove foreign matter.
Faulty Printout	No printing. No color.	1. Print head, 2. Ink tanks, 3. Purge unit	1. Replace faulty parts.
	Scrape marks or white stripes appear even after cleaning. Lines not in the printing data appear.	1. Print head, 2. Ink tanks, 3. Purge unit, 4. Print head contacts, 5. Carriage flex cable	1. Remove and reinstall print head / check the contacts, 2. Replace faulty parts.
	The paper is stained.	1. Ink mist from the paper transport section in the printer, 2. The ink absorber (platen) is dirty.	1. Feed through several sheets of clean paper, 2. Replace the ink absorber (platen), 3. Purge unit.
	Spur marks appear.	1. Deformed spur tips.	1. Replace faulty parts.
	Lines are missing.	1. Ink tanks.	1. Replace ink tanks.
	Inappropriate color tones.	1. Print head.	1. Replace faulty parts.
	Overlapping printing.	1. Platen unit (eject roller)	1. Replace faulty parts.
	No black.	1. Ink tank.	1. Perform Deep Cleaning (3 times)
	Images / text appears stretched.	1. Timing slit strip.	1. Clean grease from timing slit strip, 2. Replace the carriage board.

2.4 Troubleshooting Error Indications

- 1) Error indication when an error recoverable by the user occurs, the indicator lights green, then blinks orange repeatedly.
Check the number of orange blinks and proceed to correct the error.
- 2) Error indication when an error not resolvable by the user occurs
The indicator toggles between orange and green repeatedly.
Check the number of toggled blinks and proceed to correct the error.

Table 2-1 ERROR INDICATIONS

<i>Indicator Blink Count</i>	<i>Error Status Code</i>	<i>Probable Cause and Faulty Parts</i>
User-Recoverable Errors		
Orange 2 blinks	1000 Paper feed error	<Cause> 1. No paper was loaded. 2. During feeding, the paper did not reach the paper-end sensor. 3. During feeding, the paper's bottom edge missed the paper-end sensor. 4. The ASF sensor did not return to its initial position and the paper-end sensor concluded that there was no paper. (ASF motor may be out of sync.) <Suspect Parts> Paper feed section, sheet feeder unit, paper-end sensor, logic board
Orange 3 blinks	1300 Paper jam error	<Cause> 1. The paper-end sensor still detects the presence of paper even after 23 inches of paper ejection operation. 2. The ASF sensor did not return to its initial position and the paper-end sensor concluded that there was no paper. (Out of sync.) 3. During paper feeding abnormal timing caused the paper-end sensor to still detect paper. <Suspect Part> Paper feed section, paper-end sensor, logic board
Orange 4 blinks	1600 No ink error* ³ 1601 No ink error (Bk) 1611 No ink error (Y) 1612 No ink error (M) 1613 No ink error (C)	<Cause> The respective ink tank has run out of ink (in both the tank and the sponge) <Suspect Part> Ink tank
Orange 5 blinks	1441 Cable cover error* ¹	<Cause> The cable cover is not fitted properly. <Suspect Part> Cable cover, carriage unit

Orange 6 blinks	1401	Print head not properly installed	<Cause> Printing, cleaning etc. attempted while head is not properly installed. <Suspect Part> Print head, carriage unit.
Orange 7 Blinks	1402 1403 1405 1485	Cartridge error	<Cause> (a) The print head temperature (output of the diode sensor in the head) is close to the threshold (b) Print head internal EEPROM checksum error. <Suspect Part> Print head.
Orange 8 Blinks	1700	Waste-ink warning	<Cause> The total waste ink count recorded in the EEPROM exceeds 95% of the value stipulated as "Full". <Suspect Part> Ink absorber, logic board.
Unresolvable Errors by the User			
Orange / Green 2 toggle blinks	5100	CR error	<Cause> Abnormal carriage encoder signal. <Suspect Part> Encoder film, carriage unit, logic board, flexible cable.
Orange / Green 3 toggle blinks	6000	LF error* ²	<Cause> Abnormal LF encoder signal. <Suspect Part> Encoder film, paper feed sensor unit, logic board.
Orange / Green 4 toggle blinks	5C00	Purge sensor error	<Cause> At the sensor's ON timing it turns OFF, Green or vice versa. <Suspect Part> Purge unit, logic board.
Orange / Green 6 toggle blinks	5400	Abnormal internal temperature error	<Cause> The temperature sensor on the logic board is abnormal (disconnected etc.) <Suspect Part> Logic board.
Orange / Green 7 toggle blinks	5B00	Waste-ink full error	<Cause> The waste-ink absorber has reached 100% capacity. <Suspect Part> Ink absorber, logic board.
Orange / Green 8 toggle blinks	5200	Abnormal head temperature error	<Cause> The head temperature (output of the diode sensor in the head) is close to the threshold <Suspect Part> Print head, logic board.
Orange / Green 9 toggle blinks	6800	EEPROM error	<Cause> An error occurred while writing to the EEPROM. Checksum error (at soft power ON) <Suspect Part> Logic board.
Orange / Green 10 toggle blinks	6100	ROM error* ³	<Cause> ROM check error (at hard power ON). Error is displayed at soft power ON. <Suspect Part> Logic board.

Orange / Green S750/S520 11 toggle blinks S900/S820	6300 RAM error	<Cause> DRAM check error (at hard power ON). S900/S820 display the error at soft power ON. <Suspect Part> Logic board.
---	----------------	---

Internal error

No indication ...	Ink sensor error	<Cause> The no-ink indication is given while there is still ink. External noise (light) has affected the ink sensor. <Suspect Part> Logic board, ink sensor, ink tanks.
-------------------	------------------	--

*1 : S900 only.

*2 : S750 only.

*3 : S900/S820 only.

3. DISASSEMBLY AND REASSEMBLY

3.1 Cautions for Disassembly and Reassembly

3.1.1 Cautions against ink stains (ink path/ink mist)

During servicing, be careful not to touch the ink path and get ink stains on the printer, work surface, your hands or clothing.

The ink path includes the print head's ink tank section supply inlet, the print head's ink filter, the ink nozzles, head cap, wiper, and waste-ink absorber.

Also, in printers which have seen long-term or heavy-duty use, minute quantities of ink rebounding off the paper surface may have led to the buildup of ink mist, coating the platen, inside the front cover, and the purge section.

3.1.2 Damage due to static electricity

Friction with clothing can cause a build up of static electricity on the human body. Static electricity can destroy electrical components or alter the electrical characteristics of components.

Be extra careful when handling the logic board.

3.1.3 Deformation of spur tips

Be careful not to deform the spur tips.

The spur tips contact the paper after printing has taken place. Since the spur tips' contact area is small, any ink adhering to the spur will be a minuscule amount which can be wiped off by the spur cleaner so as not to dirty the paper. However, if the spur tips are bent or out of shape, the size of the contact area with the paper increases, along with the quantity of ink which can adhere to the spurs. If the spur cleaner cannot completely wipe off such an amount, the spurs will stain the paper with a dotted line.

3.3 Disassembly and Reassembly

See below for supplemental information and cautions for disassembling and reassembling the printer.

Refer to the *Parts Catalog* for the disassembly procedure. The illustrations in the *Parts Catalog* are numbered according to the order of disassembly.

3.3.1 Carriage lock release

NB: When releasing the carriage lock of the S900/S820, it is necessary to remove the printer unit from the bottom case unit.

Normally, when a cartridge is installed on the carriage and the power is turned off, the printer moves the carriage to the capping position to lock it. When the power is turned on, the carriage lock is normally released. However, if the printer does not operate properly, you can release the carriage lock manually.

On the front of the printer, rotate the gear as shown by the arrow in the illustration below to release the carriage lock.

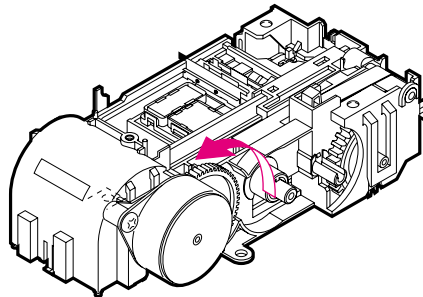

Purge Unit

Figure 2-4 Carriage Lock Release

3.3.2 Removing and installing tap screws

The printer uses tap screws to fasten the printer unit and base. The removed tap screws will have residue from the mold in which the internal thread was made. Since the residue may crush the screw threads, clean off the residue from the tap screws before re-installing or use new tap screws.

3.3.3 Installing and removing the timing slit strip

The timing slit strip is fixed in place and held taut by the torsion spring. When you install or remove the timing slit strip, you have to stretch the torsion spring. Be careful not to pull the torsion spring too much in the direction of the arrow or you will not be able to properly install the timing slit strip the next time.

Therefore, when installing or removing the timing slit strip, take great care not to pull the torsion spring too much.

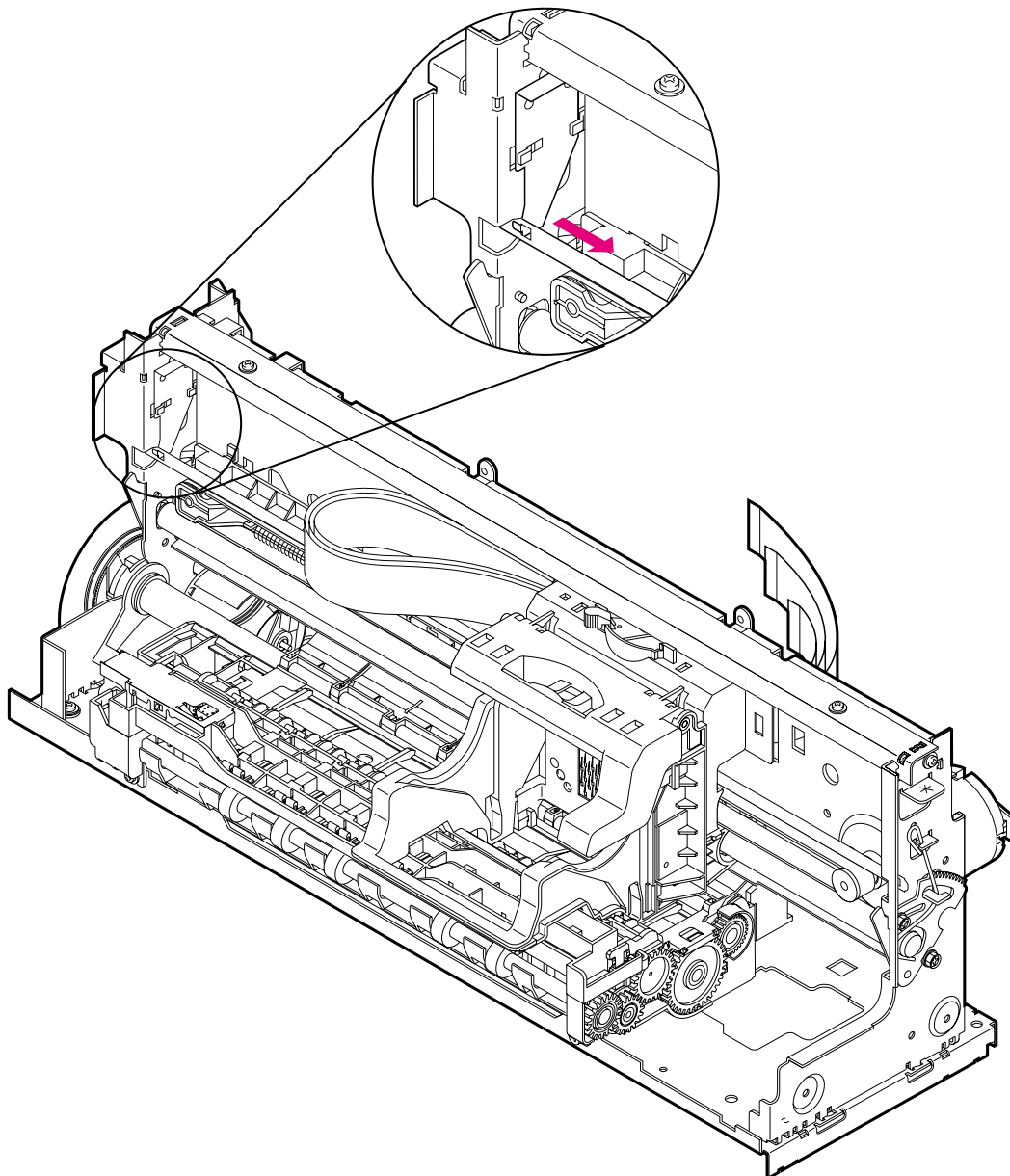

Figure 2-5 Timing Slit Strip

3.3.4 Handling the timing slit strip

- (1) Be careful not to get any grease on the timing slit strip.

If grease gets on the timing slit strip, its slits will not be read correctly, resulting in error. If grease gets on the strip, use alcohol to remove it completely.

- (2) Do not fold or scratch the timing slit strip.

If the strip is folded and a white line is created or if a slit is scratched, replace the timing slit strip.



If the timing slit strip is contaminated with grease:

Determine the extent of grease contamination and choose the appropriate method:

- a) When there is only a small amount of grease (about 2 mm width)

Step 1: Wipe the strip clean using alcohol.

Step 2: Conduct a test print.

Step 3: Check once again that no grease remains on the strip.

- b) When there is a significant amount of grease (greater than 2 mm width)

Step 1: In addition to Step 1 above, replace the carriage board assembly (since there is the danger that grease may have come in contact with the sensors on the board).

Steps 2 and 3, as above.

3.3.5 Removing and installing the logic board

Use caution when removing or installing the logic board to prevent possible damage from short circuiting.

When the printer is turned off after use, the capacitor on the logic board will continue holding a charge for some time. In this condition, shorting the components on the logic board will damage the components.

Therefore as a preventive measure, follow step (1) or (2) below before removing or installing the logic board.

- (1) After disconnecting the AC power, wait for some time

S900/S820 : about 60 seconds

S750/S520 : about 90 seconds

- (2) Use a resistance of about 100 to 500 ohms to short-circuit the capacitor terminals for 1 sec.

S900 : C401

S820 : C411

S750 : C504

S520 : C582

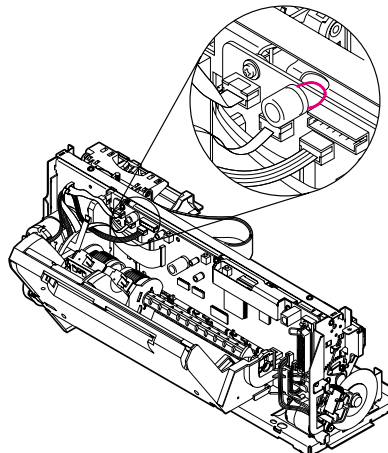

Figure 2-6 Short-Circuiting the Capacitors

3.3.6 Removal of red screws prohibited

Since adjustment of the following red screws is very difficult in the field, they must not be loosened or removed.

- (a) The two paper spacing red screws (one on the right and left).
- (b) The two screws securing the paper feed motor (S750 only)

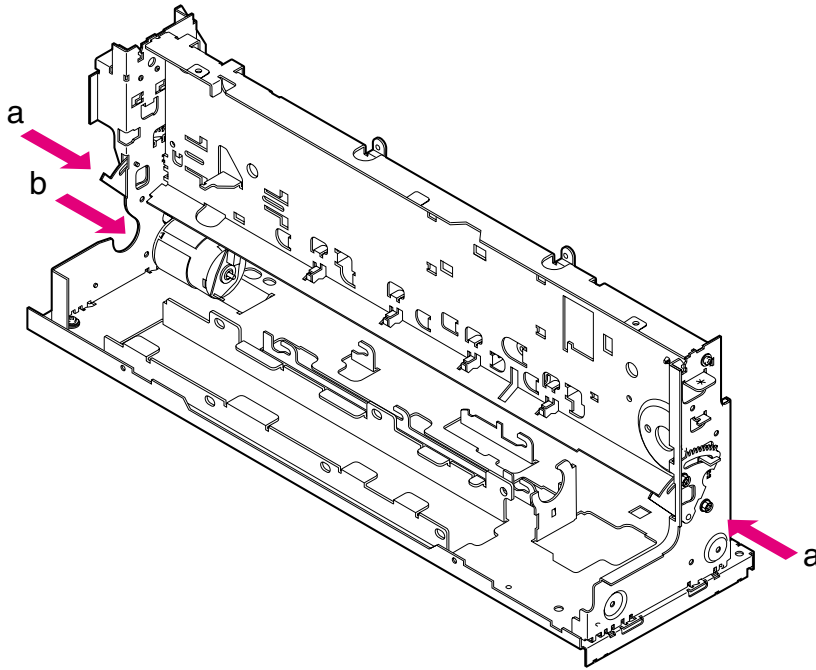

Figure 2-7 Do not Remove the Red Screws

3.3.7 Installing the logic board cover

If the logic board cover is installed incorrectly, the logic board and paper feed rollers will be obstructed and the ASF motor may go out of sync.

Note that prong A is prone to engage incorrectly. Make sure that it fits in properly.

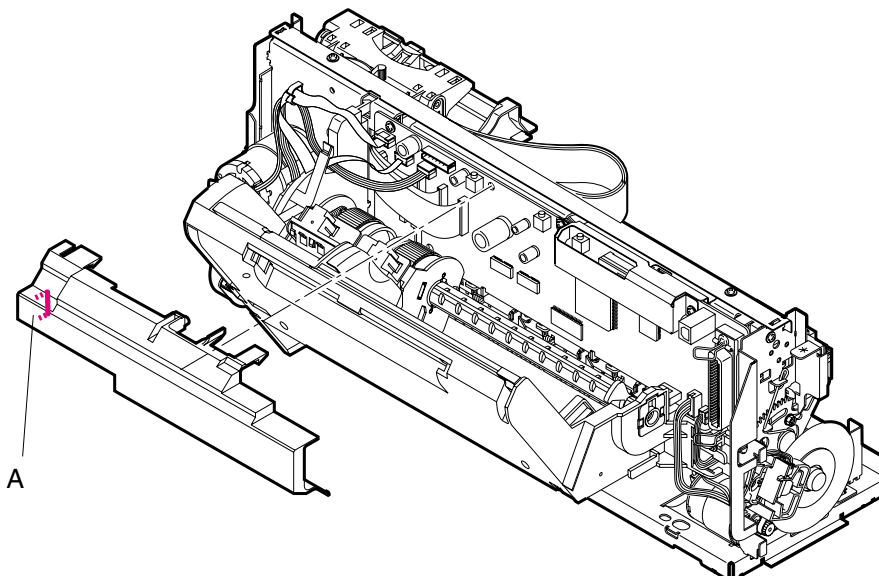

Figure 2-8 Installing the Logic Board Cover

3.3.8 Installing the control ROM cover

Make sure to install the ROM cover beneath the guide rail, before securing it in place.

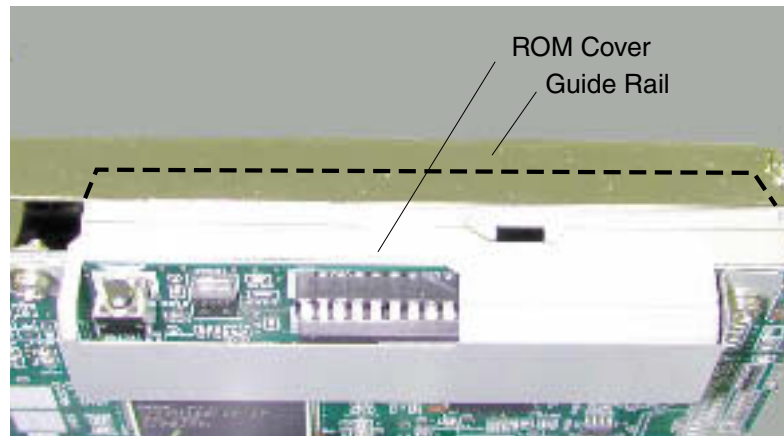

Figure 2-9 Installing the ROM Cover

4. ADJUSTMENTS AND SETTINGS AFTER DISASSEMBLY AND REASSEMBLY, AND CONFIRMATION OF OPERATION

4.1 Adjustments and Settings after Disassembly and Reassembly

4.1.1 Items for adjustments (per necessity/locations/tools)

(1) User level

Timing (after replacement of...)	Adjustment	Time	Tools
Print head	Print head printing position alignment	10 mins.	2 sheets of A4 paper

(2) Service person level

Necessary units and adjustments are listed below. When using these headings, check 4.2 Confirmation Method at the same time.

Timing (after replacement of...)	Adjustment	Time	Tools
Logic board	EEPROM settings (see page 2-29) (1) EEPROM initialization <ul style="list-style-type: none"> • to clear the EEPROM • to reset the waste-ink counter (2) Model settings <ul style="list-style-type: none"> • to establish the correct model Replace ink absorber according to need (3) Head alignment (see page 2-22)	2 mins.	None
Bottom case unit or ink absorber	EEPROM settings (1) Clear the waste-ink counter	2 mins.	None
Grease pad [S900/S820]	Grease application (see page 2-25)	2 mins.	None
Carriage guide frame Platen unit Retarding gear Carriage guide shaft Paper feed motor	Grease application (see page 2-25)	2 mins.	Flat brush

4.1.2 If EEPROM settings adjustment is necessary

When replacing the logic board, depending on the waste-ink counter value, it may be necessary to replace the ink absorber at the same time.

Refer to the table below.

Table 2-2 EEPROM SETTINGS WHEN REPLACING THE INK ABSORBER

Waste-ink counter value	0~7	7~25	25~50	50~75	75~100
S900 / S820	Waste-ink counter clear	Waste-ink counter set (25%)	Waste-ink counter set (50%)	Waste-ink counter set (75%)	Waste-ink counter clear and replace ink absorber
S750 / S520	Waste-ink counter clear	Waste-ink counter clear and replace ink absorber	←	←	←

4.1.3 Print head position adjustment

The print head has two nozzle arrays for each color. Therefore, it requires ink (dot) placement adjustment in addition to the usual bi-directional adjustment.

If dot placement is inaccurate, the pattern will have overlapping printing or gaps, resulting in black or white stripes. Therefore, when conducting alignment, choose patterns free of stripes.

Load one sheet of A4 paper in the auto sheet feeder, and use the printer driver to conduct alignment.

1) S900/S820

(1) Dot placement adjustment of the two arrays for each color.

- Black (A)
- Cyan (B)
- Magenta (C)
- Photo cyan (D)
- Photo magenta (E)

* Since yellow is difficult to judge and has little effect on images, adjustment is not necessary and the same settings as for magenta are applied automatically.

(2) Bi-directional placement adjustment

- Black bi-directional (F)



Figure 2-10 Print Position Adjustment Pattern (S900/S820)

2) S750/S520

(1) Dot placement adjustment of the two arrays for each color.

- Black—black array (A)
- Cyan—cyan array (B)
- Magenta—magenta array (C)

(2) Dot placement adjustment of two different-color arrays.

- Black—cyan/magenta/yellow (F)

(3) Bi-directional placement adjustment (as per models to date)

- Black bi-directional (D)
- Color Bi-directional (E)

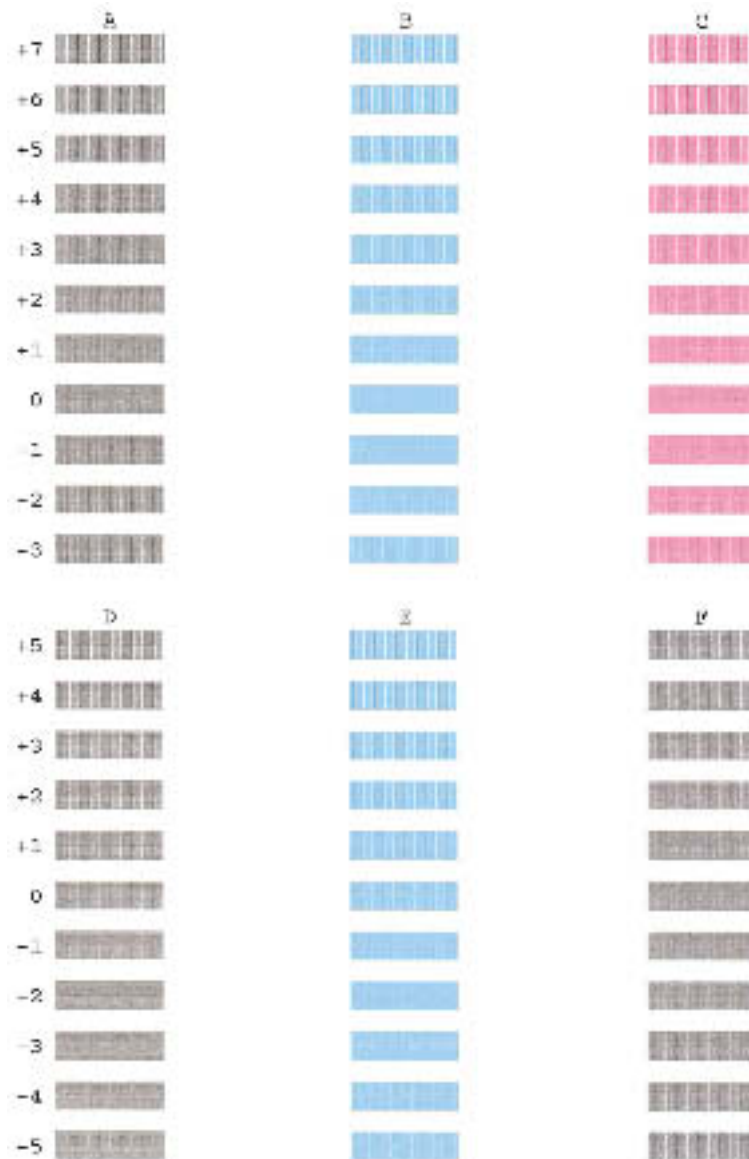

Figure 2-10 Printing Position Adjustment Pattern (S750/S520)

4.1.4 Print head seam stripe adjustment (S750)

Print head seam stripe adjustment is done to determine the degree of reduced dot printing in the high-duty image area (indicated by the arrows) comprising the seam (stripe) created between vertical bi-directional passes.

After CMY printing by the first pass, CMY is printed again in the same way in the second pass. In the case of color printing, there are two feed methods for one pass: 64 and 128. Pattern G was made with 64 nozzles, and pattern H was made with 128 nozzles.

When you execute printing with the printer driver, seven vertical patterns with a varying degree of reduced dot printing (indicated by the arrows) will be printed. Select the number of the pattern with the least noticeable seam stripe. This sets the optimum degree of reduced dot printing.

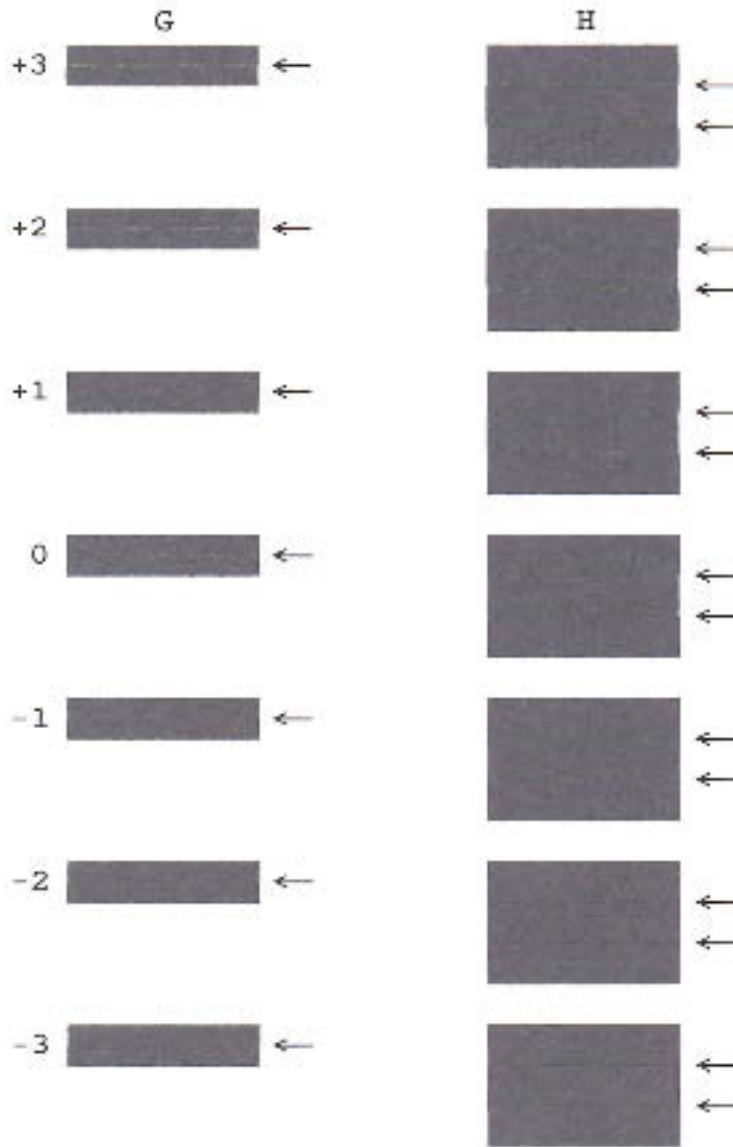

Figure 2-11 Seam Stripe Adjustment Pattern

4.1.5 Grease Application

After disassembly and reassembly, apply the necessary grease to the places shown below. Use a flat brush to spread a thin coating of grease.

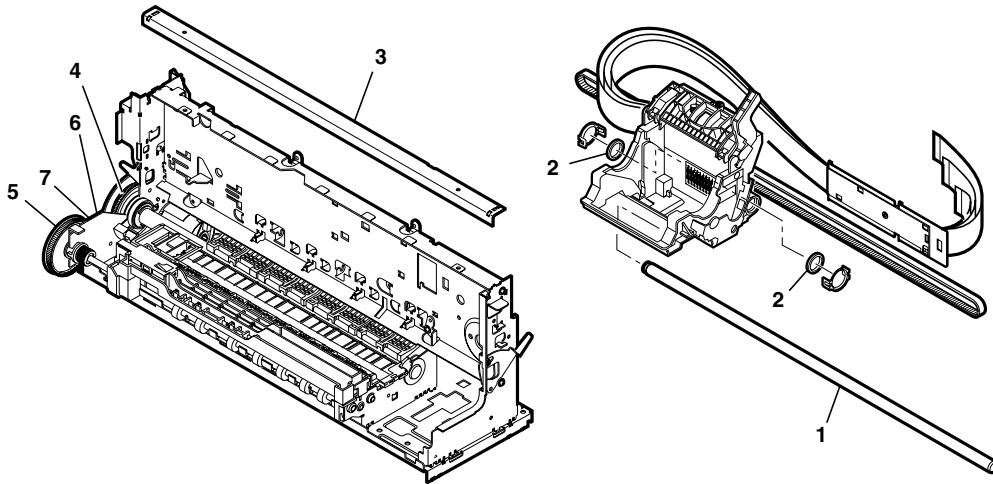

figure 2-12 Grease application

S900

Application point	Grease/oil	Quantity
1. Carriage shaft (entire surface)	EU-1	80±30mg
2. Grease pad (2 places)	EU-1	100±10mg
3. Carriage guide frame	Floil KG107A	27.5±7.5mg
4. Feed roller gear (teeth surface)	MOLYKOTE PG641	180mg +90,-45mg
5. Eject roller gear (teeth surface)	MOLYKOTE PG641	180mg +90,-45mg
6. Large retarding gear (teeth surface)	MOLYKOTE PG641	72mg +36,-18mg
7. Paper feed motor metal shaft section	MOLYKOTE PG641	12mg +6,-3mg

S820

Application point	Grease/oil	Quantity
1. Carriage shaft (entire surface)	EU-1	80±30mg
2. Grease pad (2 places)	EU-1	100±10mg
3. Carriage guide frame	Floil KG107A	27.5±7.5mg
4. Feed roller gear (teeth surface)	MOLYKOTE PG641	120mg +60,-30mg
5. Eject roller gear (teeth surface)	MOLYKOTE PG641	120mg +60,-30mg
6. Large retarding gear (teeth surface)	MOLYKOTE PG641	72mg +36,-18mg
7. Paper feed motor metal shaft section	MOLYKOTE PG641	12mg +6,-3mg

S750

Application point	Grease/oil	Quantity
1. Carriage shaft (entire surface)	Floil KG107A	250±50mg
3. Carriage guide frame	Floil KG107A	27.5±7.5mg
6. Retarding gear spindle	MOLYKOTE PG641	12+6/-3mg

S520

Application point	Grease/oil	Quantity
1. Carriage shaft (entire surface)	Floil KG107A	250±50mg
3. Carriage guide frame	Floil KG107A	27.5±7.5mg
4. Feed roller gear (teeth surface)	MOLYKOTE PG641	120mg +60,-30mg
5. Eject roller gear (teeth surface)	MOLYKOTE PG641	120mg +60,-30m



4.2 Confirmation method

After disassembly and reassembly, follow the procedures below to check the printer's operation.

1) Check visually for any grease or foreign matter contaminating the internal parts.

Make sure that the timing slit strip is clean. If there is any grease on the strip, wipe it clean with alcohol.

2) Service/factory test printout with the standalone printer

Check for the following: Missing print in the nozzle check pattern, off-position horizontal lines in the horizontal line pattern, and white stripes in any irregular printing. If any of these faults are present, clean the print head and adjust the print head position. Then make another test printout. The procedure is described in [7.1](#)

Service Mode Operations on page 2-29.



Be sure to visually check the timing slit strip for any grease, foreign matter, etc. If there is any grease, etc., on the strip, the printer may malfunction shortly after repair is completed.

5. TRANSPORTING THE PRINTER

The procedure for transporting the printer after completing repairs is described below.

5.1 Procedure

- (1) Mount the print head on the carriage.
- (2) Turn off the printer so that the carriage locks at the home position.



If the print head is not fitted on the carriage, the ink may dry and harden. For this reason, leave the head mounted on the carriage even while transporting the printer.

Also, if the carriage is not locked at the home position, it will move while the printer is being transported, which may strain the paper feed encoder film.



If you especially wish to transport the head by itself:

1. Install all the ink tanks (to prevent the inside of the nozzles drying out).
2. Place orange protective tape over the print head section.
(to prevent possible damage to the print head section by shock etc.)

6. PARTS REPLACEMENT, PERIODIC INSPECTIONS, & TOOLS

6.1 Periodic Parts Replacement

Level	Periodic Replacement Parts
User	None
Service Person	None

Level	Consumables		
User		S750/S520	S900/S820
	Black ink tank	BCI-3eBK	BCI-6BK
	Color ink tank (Cyan)	BCI-3eC	BCI-6C
	(Magenta)	BCI-3eM	BCI-6M
	(Yellow)	BCI-3eY	BCI-6Y
	(Photo cyan)		BCI-6PC
(Photo magenta)		BCI-6PM	
Service Person	None		

6.2 Periodic Inspections

Level	Periodic Inspections
User	None
Service Person	None

6.3 Tool List

Ordinary Tools	Remarks
Phillips screwdriver	For the removal and installation of screws.
Blade screwdriver	For the removal of plastic parts.
Needle-nosed pliers	For the removal and installation of springs.
Tweezers	For the disconnection and connection of flexible cables, etc
Flat brush	For applying grease.
Multi-meter	For troubleshooting.

Special Tools (Part No.)	Remarks	S900/S820	S750/S520
Grease MOLYKOTE PG-641 (CK-0562)	To be applied to the specified parts (see page 2-25)	○	○
Grease FLOIL KG107A (QY9-0057)	To be applied to the specified parts (see page 2-25)	○	○
Grease EU1 (QY9-0037)	To be applied to the specified parts (see page 2-25)	○	-

7. SERVICE-RELATED FEATURES

The printer has a service mode for accessing service settings and executing test printouts. The service mode can be accessed via the operation panel.

7.1 Service Mode Operation

- 1) With the printer turned off, hold down the *RESUME* button and press the *POWER* button (the green indicator lights and the desired service function can be selected).
- 2) While holding down the *POWER* button, let go of the *RESUME* button before pressing the *RESUME* button again twice in succession. Then let go of both *RESUME* and *POWER* buttons.
(At each press of the *RESUME* button, the indicator toggles between orange and green.)
- 3) During printer initialization, the green indicator blinks. When the green indicator stops blinking and remains on, press the *RESUME* button the specified number of times to execute the desired service function, as listed below.
(At each press of the *RESUME* button, the indicator toggles between orange and green.)

Press	Indicator	Function
0 times	Green	Power off (Even if there is no print head mounted, the carriage will return to the home position and lock.)
1 time	Orange	Service/factory test printout (Including ink sensor check)
2 times	Green	EEPROM information printout
3 times	Orange	EEPROM initialization
4 times	Green	Clears the waste-ink counter (S750/S520)
5 times	Orange	Waste-ink counter settings (S900/820) (See page 2-34)
		Destination (model) setting After reaching this service function, press the <i>RESUME</i> button the number of times specified below to set the destination.
		Setting
0 times		BJ F900 BJ F890
1 times		S900 S820 BJ F700 BJ F500
2 times		BJ F890PD S750 S520
3 times		S820D
Note: pressing more than 3 times has no effect.		
6 times		Returns to the function select stage (S750/520)
6~9 times		Not used for servicing (S900/820)
More than 10 times	Green	Returns to the function select stage (S900/820)

- 4) After selecting a service function, press the *POWER* button. The green indicator lights and the service function will be executed. (After each function is executed, the printer returns to the service function select stage.)



To cancel printing which is in progress, press the *POWER* button.

Troubleshooting

7.2 Test Printout

(1) S900/S820

The header information shows the model, control ROM version etc. This sample belongs to the S900, which differs somewhat from that of the S820.

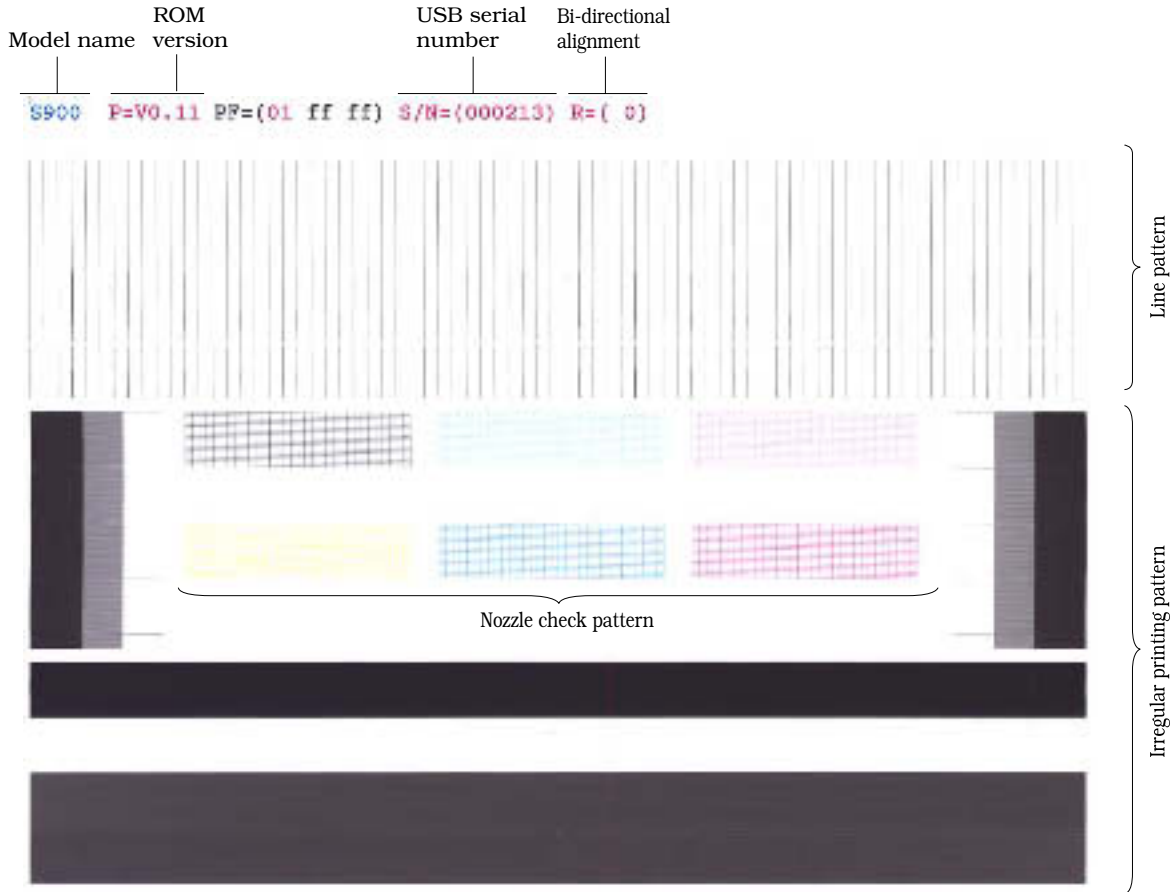
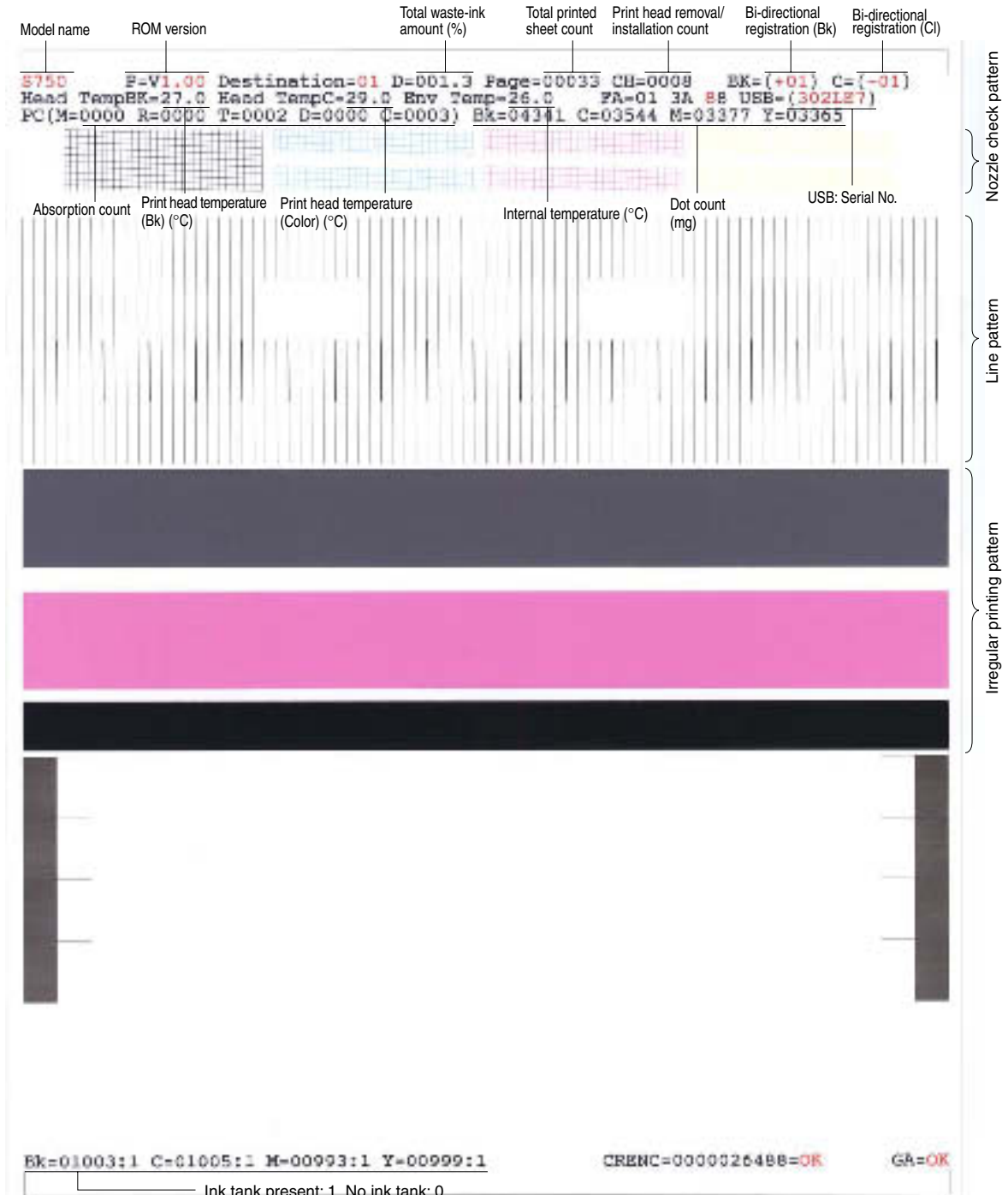

Figure 2-13 Service/Factory Test Printout (Sample)

(2) S750/S520

The service/factory test printout header shows the control ROM version, model setting, total printed sheet count, total waste-ink absorption amount and other information.



Troubleshooting

Figure 2-13 Service/Factory Test Printout (Sample)

7.3 Printing the EEPROM Information

This prints the contents of the printer's EEPROM and that of the print head. With the resulting printout allows you to see the settings and data saved in the printer.

1) S900/S820

```

Model name   ROM version   USB serial number
-----
S900 P=V0.16 PF=(01 FF FF) S/N=(0001F9) R=( 0)

DI=053.15% CH=00010/00000 PC (A=0003 B0=0005 B1=0001 C=0007 D=0001)
Waste-ink absorber amount *1 Cleaning
Page=00267 ED=(00267/00000/00000) OE/(00000/00000)/00000
Total throughput *2 Print count
SV=(0000/0000/0000) OP=(1441/1600/1401/1600/1000) WP=00227
Sevice error history User error history
UR (Ke = 00 Ko = 00 Ce = 00 Co = -01 Me = 00 Mo = -01 Ye = 00 Yo = -01)

(LCe= 00 LCo=-01 LMe= 00 LMo=-01 DIR=-02)

PT=1004701655 ST=011599 LP=011628 PD=0 IF=10 AP=000
Days past since setup
DC(K=019 C=003 M=003 Y=003 LC=003 LM=003) (0=1 January 1970.
For calculation purposes
1 year = 366 days)

ICK = (0/2042634751/0016544792)
ICC = (0/0530548948/0002866040)
ICM = (0/0682486609/0002577425)
ICY = (0/1105835164/0002539822)
ICLC = (0/1256383584/0002406504)
ICLM = (0/1210952672/0002406504)

HDEEPROM V00001 SN=01f40000 LN=11110411 ID=02

PTH(K=025 LC=025 LM=025 C=025 M=026 Y=026) PPO=000

CLR(C = 00 M = 00 Y = 00 LC = 00 LM = 00) DIR= 00
EOR(K = 00 C = 00 M = 00 Y = 00 LC = 00 LM = 00)
NG (K =000 C =000 M =000 Y =000 LC =000 LM =000)
DS (K =+03 C =+03 M =+03 Y =+03 LC =+03 LM =+03)
    
```

*1: No. of times cleaning has been conducted.

See page 3-3 for details on cleaning A to D.

*2: Print count figures.

ED: (normal paper/special paper/postcard)

OE: (borderless postcard/other borderless)

Figure 2-14 EEPROM Information Printout (Sample)

2) S750/S520

```

Model name      ROM      Waste-ink absorber
version        amount
-----
S750          P=V1.01  DI=000.95%  Page=000147  CH=00002  Bk=(00)  Cl=(00)

Head TempBk=31.0  Head TempC=29.5  Env Temp=28.0  PF(01 00 80)

PC(M=0001 R=0000 T=0003 D=0000 C=0001)  Bk=10707  C=02377  M=02299  Y=02356
-----*1 Cleaning
WP=0052  IC(BK=0 C=0 M=0 Y=0)

USB=(000343)
----- USB serial number
ER(TIME=2001/10/15-16:22  ER0=1000  ER1=1000  ER2=1000  ER3=1000)
----- Error history
UR(C=000 BK=000 BK-C=000 Y=000 M=000 G=000 H=000)

ST=2001/09/27-18:30  PWC(S=00015 H=00007)  CN(USB=1 1284=1)

PAGE(A11=00147  PP=00143  HR=00004  GP=00000  PC=00000  Other=00000)
-----*2 Print count

HDEEPROM
V00001
SN=0000-00C5
LN(03 05 01 15 00 00 03)
DI(BK=+001 CL=+001)
IL(BK=-08 C=-08 M=-08 Y=-08)
WLA=-08 WLB=-08
NGBK=000 NGC=000 NGM=000 NGY=000

```

*1: No. of times cleaning has been conducted.

M : Manual cleaning
R : Deep cleaning
T : Timed cleaning
D : Dot count cleaning
C : Head replacement cleaning

*2: Print count figures.

All : Total of all paper types
PP : Normal paper
HR: High Resolution paper
GP: Glossy paper
PC : Postcard
Other : Total of all paper types other than PP, HR, GP, PC

For details about the different types of cleaning, see page 3-3.

Figure 2-14 EEPROM Information Printout (Sample)

The following error histories, from the most recent error, are kept.

4 errors (combined service and user errors) : S750/S520

3 service errors, 5 user errors : S900/S820

7.4 Resetting the EEPROM

Resetting the EEPROM will erase all its contents, with the following exceptions:

USB-S/N (all models)

Model settings (S900/S820) are reset to overseas settings)

7.5 Waste-ink counter settings (S900/S820)

After selection, pressing the *POWER* button will execute the function and return the printer to the selection state. Go to the waste-ink counter settings selection mode in [7.1 Service Mode Operation](#). By pressing the resume button the number of times specified below, you can set the ink counter.

Presses	Indicator	Function
0 times	Green	Waste-ink counter clear
1 time	Orange	Waste-ink counter 25% setting
2 times	Green	Waste-ink counter 50% setting
3 times	Orange	Waste-ink counter 75% setting
More than 4 times	Orange blinking	No function



Part 3

TECHNICAL REFERENCE

Page	
3 - 1	1. NEW TECHNOLOGY
3 - 1	1.1 Borderless printing
3 - 2	1.2 Quiet mode
3 - 3	2. CLEANING MODES AND INK PURGE AMOUNTS
3 - 5	3. PRINT MODES

1. NEW TECHNOLOGY

1.1 Borderless printing

To allow printing of the entire paper surface, and an area exceeding the paper surface, borderless printing has been enabled. The difference from printers to date not capable of borderless printing is that the paper size may or may not need to be set in the application being used.

1. When borderless printing is selected in the driver, the driver instructs the application to send the entire data set for the paper size. At this point, the size of the requested data is finely adjusted according to the "Amount of Extension" setting.
2. The application sends data to the driver according to the specific request.
3. The driver sends the data to the printer.
4. The printer then prints the received data.

1.1.1 Borderless printing limitations

When printing the entire paper surface, or an area exceeding the surface, the following issues may arise.

(1) Dirty platen ink absorber

The platen ink absorber becomes dirty with ink. When cleaning the platen, be careful not to get this ink on the platen itself.

(2) Friction with the head caused by curled paper

Since there are no paper depressors, if curled paper is fed it can interfere with the print head and spoil the printout. Prevent paper curling by properly adjusting the paper thickness lever.

(3) Lowered speed

With the increase in vertical passes, the throughput speed of borderless printing is lower than ordinary printing.

1.2 Quiet mode

By feeding and ejecting paper gently and suppressing the sound from mechanical parts, printing noise can be suppressed. This setting (including specific operation hours) can be made from the driver when the printer is connected.

1.2.1 Quiet mode limitations

(1) Lowered throughput

Since the speed of paper feeding and ejection is slower, throughput is lower.

(2) Settings reset at power OFF

The Quiet mode setting is not stored within the printer itself (in the EEPROM), so that it will be reset (turned off) when the printer is powered OFF.

1.3 Remaining-ink amount detection (S900/S820)

The remaining-ink function determines whether there is ink in the ink chamber (yes/no) and uses dot-count logic to display the amount of ink remaining in the ink chamber.

1.3.1 Limitations when using the remaining-ink amount detection function

The amount of remaining ink may not be displayed accurately due to dot count error margins or ink tank replacement.

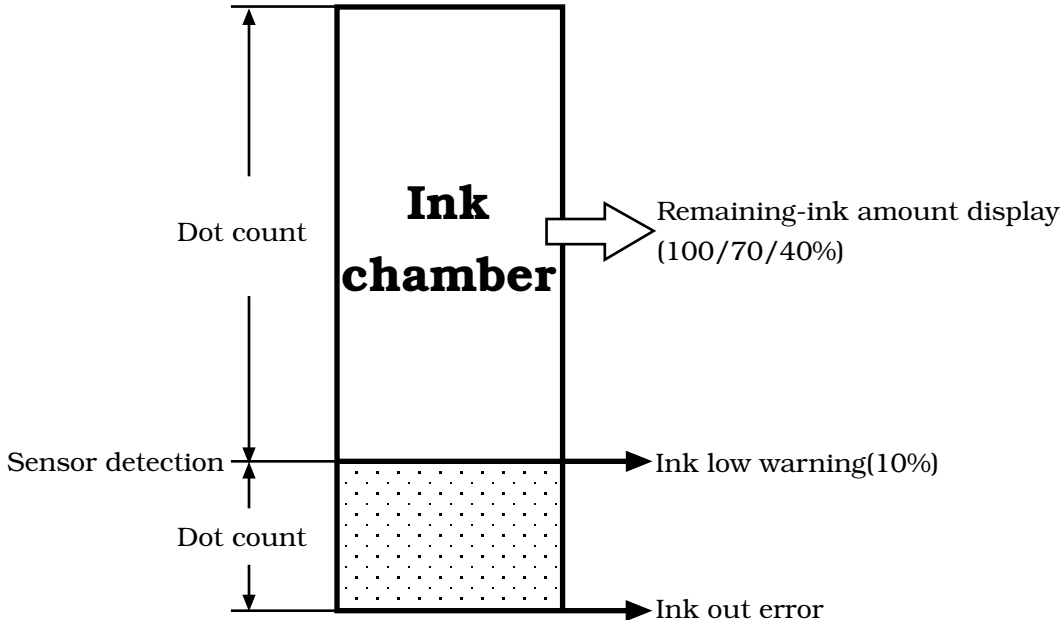

Figure 3-1 Remaining-ink amount detection

2. CLEANING MODES AND INK PURGE AMOUNTS

Automatic print head cleaning is performed as effectively and efficiently as possible according to given conditions in order to eliminate and prevent printing imperfections due to bubbles, foreign matter, clogging etc.

Except for the situations below, cleaning is timed to take place immediately before printing.

* dot count cleaning: after paper has been ejected

* manual cleaning/Deep Cleaning: user operation

* delivery of the printer: when the access cover is closed (S750/S520)

Table 3-1 CLEANING MODES (S900/S820)

Conditions	Details	Purge amount in gms (S900/S820)*1	Cleaning mode*2*3
120 hours timed cleaning	When between 120 and 480 hours have passed since the last cleaning operation	1.1/0.64	A
Dot count cleaning	When a specified dot count has been exceeded since the previous cleaning		
After hard power ON (when the time has not yet been set)	When a test print is performed from the standalone printer		
480 hours timed cleaning	When more than 480 hours have passed since the previous cleaning	1.55/0.84	B0
At ink tank replacement	When the ink sensor status changes from NO to YES		
When manual cleaning is performed	Conducted either from the operation panel or the driver		B1
When the heads are uncapped at soft power ON	When proper capping did not take place at the last power OFF	2.8/1/45	C
At head replacement	When a print head is removed and installed		
When Deep Cleaning is conducted	Driver operation		
On delivery of the printer	The first cleaning which takes place after the printer has left the factory	2.8/1.65	D

*1 The purge amount is a total of the 6 colors.

*2 When several conditions are met, the priority order of cleaning modes is A<B0<B1<C<D.

*3 The EEPROM information printout's figures for no. of times cleaning has been conducted indicate details on cleaning modes.

Table 3-1 CLEANING MODES (S750/S520)

Conditions	Details	Purge amount in gms BK/CL(g)	Cleaning mode
Execution of manual cleaning	Executed from the operation panel or the printer drive	0.14/0.36	M
Execution of Deep Cleaning	Executed from the printer driver	1.58/1.18	R
Timed Cleaning	Between 24 and 336 hours have passed since the previous cleaning (Bk)	0.14/0.36	T
	Between 120 and 336 hours have passed since the previous cleaning (Cl)		
Long-duration timed cleaning	More than 336 hours have passed since the previous cleaning	0.45/0.72	
Dot count cleaning	When a specified dot count has been exceeded since the previous cleaning	0.14/.036	D
At head replacement	When a print head is removed and installed	0.45/1.18	C
Ink tank replacement	When the ink sensor status changes from NO to YES	0.30/0.72	
On delivery of the printer (or at first print head position adjustment)	Cleaning when a head is installed for the first time after the printer has left the factory.	0.45/1.18	---
When the heads are uncapped at soft power ON	When proper capping did not take place at the last power OFF	0.30/0.72	

3. PRINT MODES

Table 3-2 PRINT MODES (S900/S820)

Paper type		Quality setting 5	Quality setting 4	Quality setting 3	Quality setting 2	Quality setting 1
Normal paper	No. of passes / Print direction	1 pass / Bi-directional	Bk: 1 pass / Bi-directional Cl: 2 pass / Uni-directional			8 pass / Bi-directional
	Color	4 colors (only Bk when printing greyscale)	4 colors			6 colors
	Resolution (dpi) Print quality	600 x 1200 Draft	1200 x 1200 Standard			2400 x 1200 ---
HR-101	No. of passes / Print direction			4 pass / Bi-directional	4 pass / Uni-directional	8 pass / Bi-directional
	Color			6 colors	6 colors	6 colors
	Resolution (dpi) Print quality			1200 x 1200 ---	1200 x 1200 High	1200 x 1200 ---
PR-101 PC-101 PH-101	No. of passes / Print direction				4 pass / Bi-directional	8 pass / Bi-directional
	Color				6 colors	6 colors
	Resolution (dpi) Print quality				1200 x 1200 High	2400 x 1200 ---
GP-301 FM-101 KH-201	No. of passes / Print direction			4 pass / Bi-directional	4 pass / Bi-directional	8 pass / Bi-directional
	Color			6 colors	6 colors	6 colors
	Resolution (dpi) Print quality			1200 x 1200 ---	1200 x 1200 High (S820)*1	1200 x 1200 High (S900)
Inkjet postcard	No. of passes / Print direction			4 pass / Bi-directional	4 pass / Uni-directional	8 pass / Bi-directional
	Color			6 colors	6 colors	6 colors
	Resolution (dpi) Print quality			1200 x 1200 Standard	1200 x 1200 High	2400 x 1200 ---
Postcard	No. of passes / Print direction	1 pass / Bi-directional	Bk: 1 pass / Bi-directional Cl: 2 pass / Uni-directional			8 pass / Bi-directional
	Color	4 colors (Only Bk when printing greyscale)	4 colors			6 colors
	Resolution (dpi) Print quality	600 x 1200 Draft	1200 x 1200 Standard			2400 x 1200 ---
HG-201	No. of passes / Print direction					8 pass / Bi-directional
	Color					6 colors
	Resolution (dpi) Print quality					1200 x 1200 High
TR-10	No. of passes / Print direction			8 pass / Bi-directional		
	Color			4 colors		
	Resolution (dpi) Print quality			1200 x 1200 Standard		
CF-102	No. of passes / Print direction	4 pass / Bi-directional		8 pass / Bi-directional		
	Color	4 colors		4 colors		
	Resolution (dpi) Print quality	1200 x 1200 Draft		1200 x 1200 Standard		
Envelope	No. of passes / Print direction	1 pass / Bi-directional	Bk: 1 pass / Bi-directional Cl: 2 pass / Uni-directional			8 pass / Bi-directional
	Color	4 colors (Only Bk when printing greyscale)	4 colors			6 colors
	Resolution (dpi) Print quality	600 x 1200 Draft	1200 x 1200 Standard			2400 x 1200 ---

Technical Reference

*1: An option only for the S820
 Print quality is selectable in the driver properties.
 Shaded sections indicate default settings.

Table 3-2 PRINT MODES (S750/S520)

Paper type		Quality setting 5	Quality setting 4	Quality setting 3	Quality setting 2	Quality setting 1
Normal paper	No. of passes Pigment or CMY Resolution (dpi)	1 pass Pigment 600 x 600	1 pass Pigment Bk: 600 x 600 C.M: 1200 x 1200 Y: 600 x 1200	1/4 pass Pigment <- ---	4 pass Pigment Bk: 600 x 600 C.M,Y:1200x1200	
	Print quality	Draft	Standard		High	
HR-101 Special high quality paper	No. of passes Pigment or CMY Resolution (dpi)			4 pass CMY C.M,Y:1200x1200	6 pass <- <-	
	Print quality			Standard	High	
PR-101 PC-101 PH-101 Pro photo paper	No. of passes Pigment or CMY Resolution (dpi)				4 pass CMY C.M,Y:1200x1200	6 pass <-
	Print quality				Standard	High
GP-301 FM-101 KH-201 Glossy paper	No. of passes Pigment or CMY Resolution (dpi)			4 pass CMY C.M,Y:1200x1200	6 pass CMY C.M,Y:1200x1200	12 pass CMY C.M,Y:1200 x 400
	Print quality			Standard	High	---
Inkjet postcard	No. of passes Pigment or CMY Resolution (dpi)		2 pass CMY C.M: 1200 x 1200 Y: 600 x 1200	4 pass <- C.M,Y:1200x1200		
	Print quality		Standard	High		
Postcard	No. of passes Pigment or CMY Resolution (dpi)		3 pass Pigment + CMY Bk: 600 x 600 C.M: 1200 x 1200 Y: 600 x 1200	4 pass <- Bk: 600 x 600 C.M,Y:1200x1200		
	Print quality		Standard	High		
HG-201 Glossy film	No. of passes Pigment or CMY Resolution (dpi)				4 pass CMY C.M,Y:1200x1200	6 pass <- <-
	Print quality				Standard	High
TR-10 T-shirt transfer	No. of passes Pigment or CMY Resolution (dpi)			6 pass CMY C.M,Y:1200x1200		
	Print quality			High		
CF-102 OHP film	No. of passes Pigment or CMY Resolution (dpi)			4 pass Pigment + CMY C.M,Y:1200x1200	6 pass <- C.M,Y:1200x1200	
	Print quality			Standard	High	
Envelope	No. of passes Pigment or CMY Resolution (dpi)		3 pass Pigment + CMY Bk: 600 x 600 C.M: 1200 x 1200 Y: 600 x 1200	4 pass <- Bk: 600 x 600 C.M,Y:1200x1200		
	Print quality		Standard	High		

NB: The printing direction in all cases is bi-directional



Part 4

APPENDIX

Page	
	(S900)
4 - 1	1. CONNECTOR LOCATIONS AND PIN CONFIGURATIONS
4 - 1	1.1 Logic Board
4 - 4	1.2 Carriage Board
4 - 5	1.3 Print Head
	(S820)
4 - 6	1. CONNECTOR LOCATIONS AND PIN CONFIGURATIONS
4 - 6	1.1 Logic Board
4 - 9	1.2 Carriage Board
4 -10	1.3 Print Head
	(S750)
4 -11	1. CONNECTOR LOCATIONS AND PIN CONFIGURATIONS
4 -11	1.1 Logic Board
4 -14	1.2 Carriage Board
4 -15	1.3 Print Head
	(S520)
4 -16	1. CONNECTOR LOCATIONS AND PIN CONFIGURATIONS
4 -16	1.1 Logic Board
4 -19	1.2 Carriage Board
4 -20	1.3 Print Head
4 -21	2. PROBLEMS LEFT REMANING

1. CONNECTOR LOCATIONS AND PIN CONFIGURATIONS

1.1 Logic Board

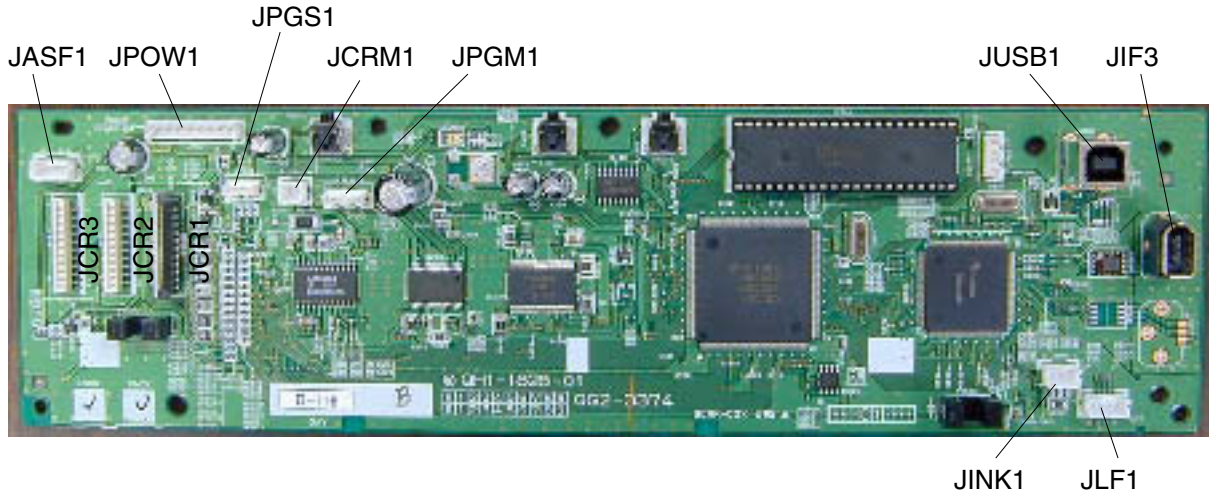

Figure 4-1 Logic Board

JUSB1 (USB interface connector)

Pin No.	Signal	IN/OUT	Function
1	USB_VBI	OUT	Cable power source
2	USB_DN	IN/OUT	Differential data signal
3	USB_DP	IN/OUT	Differential data signal
4	GND		

JIF1 (IEEE1394 interface connector)

Pin No.	Signal	IN/OUT	Function
1	open		
2	GND		
3	TPB2N	IN/OUT	Differential data signal TPB
4	TPB2P	IN/OUT	Differential data signal TPB
5	TPA2N	IN/OUT	Differential data signal TPA
6	TPA2P	IN/OUT	Differential data signal TPA

Appendix

JCR1 (Carriage flexible cable connector)

Pin No.	Signal	IN/OUT	Function
1,2	VH		
3~6	HVDD		
7~10	GND		
11	CRENCB	IN	Encoder output phase B
12	EVDD		Encoder power source
13	CRENCA	IN	Encoder output phase A
14	GND		
15	HDSSEN	IN	Head YES/NO
16	HEEP_SK	OUT	Head EEPROM clock signal
17	HEEP_WD	IN/OUT	Head EEPROM data signal
18	HEEP_CS	OUT	Head EEPROM chip select
19	SNSSEN	IN	Scanner YES/NO
20	SNENA	OUT	Scanner enable
21	DHE	OUT	Dummy driving signal
22	TSOLMC	IN	LMC chip temperature status output
23	DT7	IN	DT7
24	DT6	IN	DT6
25	DATAK	IN/OUT	KDATA/DT5
26	DATALC	IN/OUT	LCDATA/DT4
27	DATALM	IN/OUT	LMDATA/DT3
28	DATAC	IN/OUT	CDATA/DT2
29	DATAM	IN/OUT	MDATA/DT1
30	DATAY	IN/OUT	YDATA/DT0
31	HEKX	OUT	K head driving signal
32	HELX	OUT	LC head driving signal
33	HELMX	OUT	LM head driving signal
34	HECX	OUT	C head driving signal
35	HEMX	OUT	M head driving signal
36	HEYX	OUT	Y head driving signal
37	BG	OUT	Data transfer synchronization signal
38	GND		
39	HCLK	OUT	Data transfer clock
40	GND		

JCR2 (Carriage flexible cable connector)

Pin No.	Signal	IN/OUT	Function
1~8	VH		
9	TSOMY	IN	MY chip temperature status output
10	SNSSET	IN	Overseas/domestic sensor
11~20	GND		

JCR3 (Carriage flexible cable connector)

Pin No.	Signal	IN/OUT	Function
1~8	VH		
9	TSOKLC	IN	KLC chip temperature status output
10	VH		
11~20	GND		

JPOW1 (DC power connector)

Pin No.	Signal	IN/OUT	Function
1,2	VH		Head voltage (+16V)
3	VM		Motor voltage (+28V)
4,5	GND		
6	5V		Logic board voltage
7	GND		
8	VHREM	OUT	VH remote

JPGS1 (Purge sensor connector)

Pin No.	Signal	IN/OUT	Function
1	POW		Power
2	GND		GND
3	SNS_PG		PG sensor port

JINK1 (Ink sensor connector)

Pin No.	Signal	IN/OUT	Function
1	POW		Power
2	GND		GND
3	AD_INK		Ink sensor port

JASF1 (ASF motor connector)

Pin No.	Signal	IN/OUT	Function
1	A	OUT	ASF motor phase A
2	B	OUT	ASF motor phase B
3	\overline{A}	OUT	ASF motor phase \overline{A}
4	\overline{B}	OUT	ASF motor phase \overline{B}

JPGM1 (Purge motor connector)

PIN No.	Signal	IN/OUT	Function
1	A	OUT	PG motor phase A
2	B	OUT	PG motor phase B
3	\overline{A}	OUT	PG motor phase \overline{A}
4	\overline{B}	OUT	PG motor phase \overline{B}

JLFM1 (Paper feed motor connector)

PIN No.	Signal	IN/OUT	Function
1	\overline{B}	OUT	LF motor phase \overline{B}
2	\overline{A}	OUT	LF motor phase \overline{A}
3	B	OUT	LF motor phase B
4	A	OUT	LF motor phase A

JCRM1 (Carriage motor connector)

PIN No.	Signal	IN/OUT	Function
1	-	OUT	CR motor - phase
2	+	OUT	CR motor + phase

1.2 Carriage Board

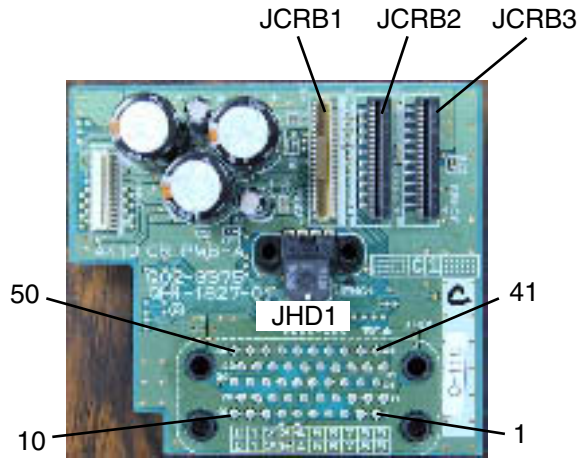

Figure 4-2 Carriage Board

JCRB1 (Carriage flexible cable connector)

See Page 4-2 (JCR1 Carriage flexible cable connector pin description)

Note that Pin No.and IN/OUT reverse.

JCRB2 (Carriage flexible cable connector)

See Page 4-2 (JCR2 Carriage flexible cable connector pin description)

Note that Pin No.and IN/OUT reverse.

JCRB3 (Carriage flexible cable connector)

See Page 4-2 (JCB3 Carriage flexible cable connector pin description)

Note that Pin No.and IN/OUT reverse.

JHD1 (Print head connector section)

Pin No.	Signal	IN/OUT	Function
1~50			<i>See page 4-5 (Print head pin description)</i>

1.3 Print Head

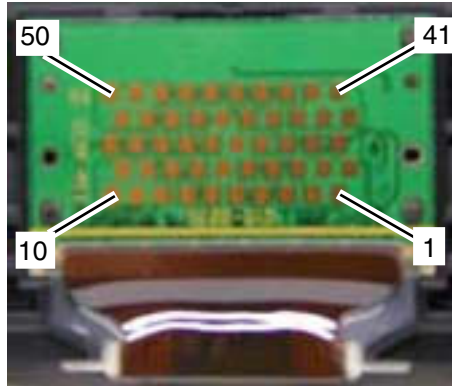

Figure 4-3 Print Head

Pin No.	Signal	IN/OUT	Function
1,2,8~13	GNDH		
19,20			
3	DATAK	OUT	KDATA
4	DATALC	OUT	LCDATA
5	DATALM	OUT	LMDATA
6	DATAC	OUT	CDATA
7	DATAM	OUT	MDATA
14	TSOKLC	IN	KLC chip temperature status output
15	BG	OUT	Synchronized transfer signal
16	HDSEN	IN	Head YES/NO (GND for head)
17	HCLK	OUT	Head data transfer clock
18	DATAY	OUT	YDATA
21	HELMX	OUT	LM driving signal
22	HELXC	OUT	LC driving signal
23	HEKX	OUT	K driving signal
24	3.3V		
25,36	GND		
26	VSS-A		Analog GND
27	VDD-A		OPEN
28	HEYX	OUT	Y driving signal
29	HEMX	OUT	M driving signal
30	HECX	OUT	C driving signal
31~33,39~42	VH		
48~50			
34	3.3V		
35	DHE	OUT	Dummy nozzle driving signal
37	TSOLMC	IN	LMC chip temperature status output
38	TSOMY	IN	MY chip temperature status output
43	E_CS	OUT	Head EEPROM chip select
44	E_SK	OUT	Head EEPROM clock signal
45	E_DI	OUT	Head EEPROM data signal
46	E_DO	IN	Head EEPROM data signal
47	VHT		VH short on the logic board

1. CONNECTOR LOCATIONS AND PIN CONFIGURATIONS

1.1 Logic Board

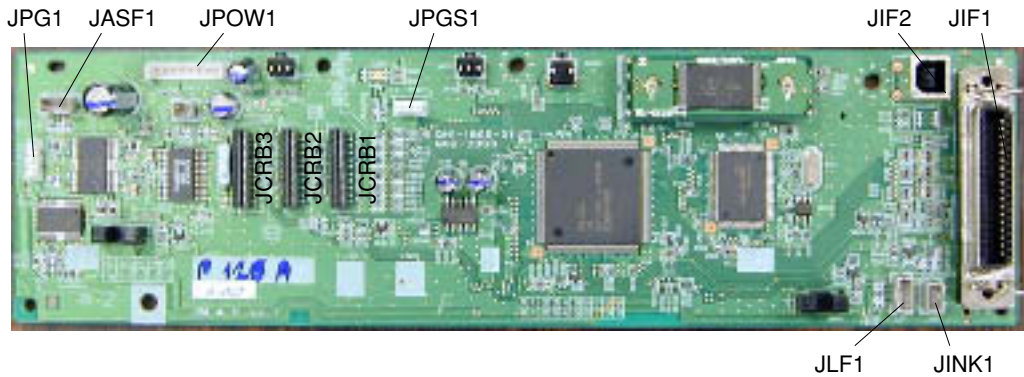

Figure 4-4 Logic Board

JIF1 (Parallel interface connector)

Pin No.	Compatible mode	Nibble mode	ECP mode
1	$\overline{\text{STROBE}}$	HostClk	HostClk
2	DATA1	Data1	Data1
3	DATA2	Data2	Data2
4	DATA3	Data3	Data3
5	DATA4	Data4	Data4
6	DATA5	Data5	Data5
7	DATA6	Data6	Data6
8	DATA7	Data7	Data7
9	DATA8	Data8	Data8
10	$\overline{\text{ACKNLG}}$	PrtClk	PeriphClk
11	BUSY	PrtBusy	PeriphAck
12	P.E.	AckDataReq	AckReverse
13	SELECT	Xflag	Xflag
14	AUTO FEED XT	HostBusy	HostAck
15	N.C	TBD	TBD
16	GND	Gnd	Gnd
17	GND	Gnd	Gnd
18	+5.0V	Vcc	Vcc
19	STROBE-RET (GND)	Signal Gnd	Signal Gnd
20	DATA1-RET (GND)	Signal Gnd	Signal Gnd
21	DATA2-RET (GND)	Signal Gnd	Signal Gnd
22	DATA3-RET (GND)	Signal Gnd	Signal Gnd
23	DATA4-RET (GND)	Signal Gnd	Signal Gnd
24	DATA5-RET (GND)	Signal Gnd	Signal Gnd
25	DATA6-RET (GND)	Signal Gnd	Signal Gnd
26	DATA7-RET (GND)	Signal Gnd	Signal Gnd
27	DATA8-RET (GND)	Signal Gnd	Signal Gnd
28	ACKNLG-RET (GND)	Signal Gnd	Signal Gnd
29	BUSY-RET (GND)	Signal Gnd	Signal Gnd
30	P.E.-RET (GND)	Signal Gnd	Signal Gnd
31	$\overline{\text{INIT}}$	INIT	ReverseReq
32	$\overline{\text{ERROR}}$	DataAvail	PeriphReq
33	GND	TBD	TBD
34	N.C	TBD	TBD
35	+5.0V	TBD	TBD
36	$\overline{\text{SELECT IN}}$	1284Active	1284Active

JIF2 (USB interface connector)*See page 4-1 (BJ F900 JUSB1 USB interface connector)***JCRB1 (Carriage flexible cable connector)**

Pin No.	Signal	IN/OUT	Function
1~3	VHGND		
4	DATAM	OUT	
5	SOMY	IN	MY chip status output
6	TOMLC	IN	MLC chip status output
7	TOMY	IN	MY chip temperature output
8	HEAD_SEN	IN	Head YES/NO
9	DATAAC	OUT	
10	DATAML	OUT	
11	HEKCL	OUT	KCL heat signal
12	BE2	OUT	Block enable 2
13	BG	OUT	Data latch signal
14	BE3	OUT	Block enable 3
15	DATAACL	OUT	
16	CSCR	OUT	Head EEPROM chip select
17	CRWD	IN/OUT	Head EEPROM data signal
18	CRSK	OUT	Head EEPROM block signal
19,20	HVDD	out	

JCRB2 (Carriage flexible cable connector)

Pin No.	Signal	IN/OUT	Function
1~3	VHGND		
4	DATAY	OUT	
5	HEMY	OUT	MY heat signal
6	SOMLC	IN	MLC chip status output
7	TOKCL	IN	KCL chip temperature output
8	GND		
9	HCLK	OUT	Data transfer block
10	GND		
11	HEMLC	OUT	MLC heat signal
12	BE1	OUT	Block enable 1
13	DATAK	OUT	
14	BE0	OUT	Block enable 0
15	SOKCL	IN	KCL chip status output
16	DHE	OUT	Dummy drive signal
17	SENSEPOW	OUT	Encoder power
18	ENCB	IN	Encoder output phase B
19	ENC_G		Encoder GND
20	ENCA	IN	Encoder output phase A

JCRB3 (Carriage flexible cable connector)

Pin No.	Signal	IN/OUT	Function
1~7	VHGND		VHGHN
8~20	VH	OUT	VH power

JPOW1 (DC power connector)

Pin No.	Signal	IN/OUT	Function
1	VH		Head voltage (+11V)
2	VH		Head voltage (+11V)
3	VM		Motor voltage (+28V)
4,5	GND		
6	5V		Logic voltage
7	GND		
8	VHON	OUT	VH remote

JPGS1 (Purge sensor connector)

Pin No.	Signal	IN/OUT	Function
1	POW		Power
2	GND		GND
3	PGS	IN	PG sensor signal

JINK1 (Ink sensor connector)

Pin No.	Signal	IN/OUT	Function
1	INK_S		Ink sensor signal
2	GND		GND
3	POW		Power

JASF1 (ASF motor connector)

Pin No.	Signal	IN/OUT	Function
1	\overline{B}	OUT	ASF motor phase \overline{B}
2	\overline{A}	OUT	ASF motor phase \overline{A}
3	B	OUT	ASF motor phase B
4	A	OUT	ASF motor phase A

JPG1 (Purge motor connector)

Pin No.	Signal	IN/OUT	Function
1	A	OUT	PG motor phase A
2	B	OUT	PG motor phase B
3	\overline{A}	OUT	PG motor phase \overline{A}
4	\overline{B}	OUT	PG motor phase \overline{B}

JLF1 (Paper feed motor connector)

Pin No.	Signal	IN/OUT	Function
1	A	OUT	LF motor phase A
2	B	OUT	LF motor phase B
3	\overline{A}	OUT	LF motor phase \overline{A}
4	\overline{B}	OUT	LF motor phase \overline{B}

JCR1 (Carriage motor connector)

Pin No.	Signal	IN/OUT	Function
1	A+	OUT	CR motor + phase
2	B	OUT	CR motor - phase

1.2 Carriage Board

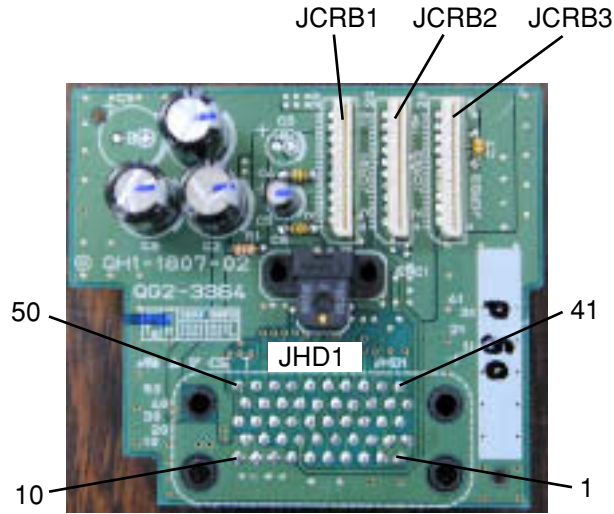

Figure 4-5 Carriage Board

JCRB1 (Carriage flexible cable connector)

See page 4-7 (JCRB1 Carriage flexible cable connector pin description)
 Note that Pin No.and IN/OUT reverse.

JCRB2 (Carriage flexible cable connector)

See page 4-7 (JCRB2 Carriage flexible cable connector pin description)
 Note that Pin No.and IN/OUT reverse.

JCRB3 (Carriage flexible cable connector)

See page 4-7 (JCRB3 Carriage flexible cable connector pin description)
 Note that Pin No.and IN/OUT reverse.

JHD1 (Print head connector section)

Pin No.	Signal	IN/OUT	Function
1~50			<i>See page 4-10 (Print head pin description)</i>

1.3 Print Head

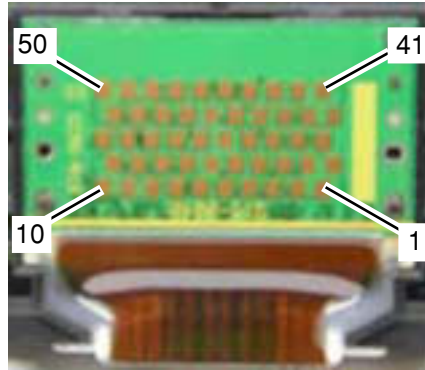

Figure 4-6 Print Head

Pin No.	Signal	IN/OUT	Function
1,2,8~12,20	VHGND		
3	DATAK	OUT	
4	DATAKL	OUT	
5	DATAML	OUT	
6	DATAC	OUT	
7	DATAM	OUT	
13	BE3	OUT	Block enable 3
14	TOKCL	IN	KCL chip temperature status output
15	BG	OUT	Data latch signal
16,26,36	VSS	IN	
17	HCLK	OUT	Data transfer clock
18	DATAY	OUT	
19	BE1	OUT	Block enable 1
20	VHGND		
21	HEKCL	OUT	KCL heat signal
22	SOKCL	IN	KCL chip status output
23	SOMLC	IN	MLC chip status output
24,27,34	HVDD	OUT	
25	HED_SEN	IN	Head YES/NO
28	SOMY	IN	MY chip status output
29	HEMY	OUT	MY heat signal
30	HEMLC	OUT	MLC heat signal
31,32,40~42 47~50	VH		
33	BE0	OUT	Block enable 0
35	DHE	OUT	Dummy drive signal
37	TOMLC	IN	MLC chip temperature status output
38	TOMY	IN	MY chip temperature status output
39	BE2	OUT	Block enable 2
43	CSCR	OUT	Head EEPROM chip select
44	EEP_SK	OUT	Head EEPROM clock signal
45	E_DI	OUT	Head EEPROM data signal
46	E_DO	IN	Head EEPROM data signal

1. CONNECTOR LOCATIONS AND PIN CONFIGURATIONS

1.1 Logic Board

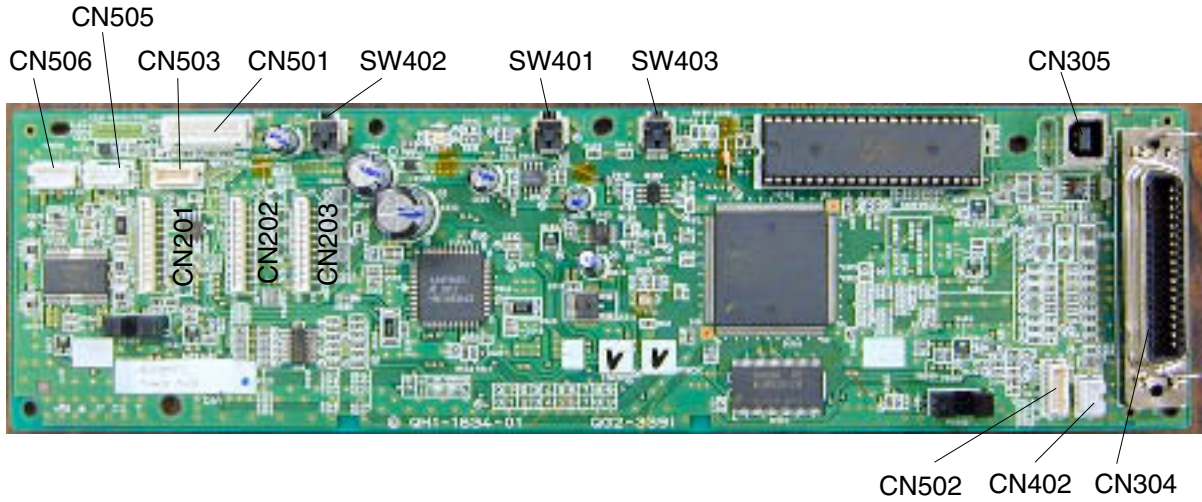

Figure 4-7 Logic Board

CN201 (Carriage flexible cable connector) ↔ J1 : Carriage Board

Pin No.	Signal	IN/OUT	Function	J1 Pin No.
1~11	HVH	OUT	Color and black heater driving voltage(19V)	Same as CN201 pin no.s
12~15	HVDD	OUT	Print head logic power source	
	H_ENB0	OUT	Black nozzle heat enable signal	
	H_ENB1	OUT	Color nozzle heat enable signal (Even/odd array's odd block)	
	H_ENB2	OUT	Color nozzle heat enable signal (Even/odd array's odd block)	

CN202 (Carriage flexible cable connector) ↔ J2 : Carriage board

Pin No.	Signal	IN/OUT	Function	J2 Pin No.
1~10	H_GND	...	HVH/HVDD GND	Same a CN202 pin no.s
11~15,18	LOGIC_GND	...	Logic ground	
16,17	VSEN	OUT	Carriage encoder sensor power source	
19	DIA0	IN	Head temperature sensor's (diode) anode side (black)	
20	DIK0	...	Head temperature sensor's (diode) cathode side (black)	

Appendix

CN203 (Carriage flexible cable connector) ↔ J3 : Carriage board

Pin No.	Signal	IN/OUT	Function	J3 Pin No.
1	H_D0	OUT	Black even array nozzle data signal	Same as CN203 pin no.s
2	H_D1	OUT	Black odd array nozzle data signal	
3	H_D2	OUT	Cyan even array nozzle data signal	
4	H_D3	OUT	Cyan odd array nozzle data signal	
5	H_D4	OUT	Magenta even array nozzle data signal	
6	H_D5	OUT	Magenta odd array nozzle data signal	
7	H_D6	OUT	Yellow even array nozzle data signal	
8	H_D7	OUT	Yellow odd array nozzle data signal	
9	H_EEPROM_CS	OUT	Print head EEPROM chip select signal	
10	H_EEPROM_SK	OUT	Print head EEPROM serial data clock signal	
11	H_EEPROM_D	OUT	Print head EEPROM serial data signal in the print head	
12,15,16	LOGIC_GND	...	Logic ground	
13	H_LATCH	OUT	Data latch enable signal	
14	H_CLK	OUT	Clock signal	
17	ENCA	IN	Carriage encoder signal	
18	ENCB	IN	Carriage encoder signal	
19	DIA1	IN	Head temperature sensor's (diode) anode side (color)	
20	DIK1	...	Head temperature sensor's (diode) cathode side (color)	

CN304 (Parallel interface connector)

See page 4-6 (S820 JIF1 interface connector)

CN305 (USB interface connector)

See page 4-1 (S900 JUSB1 interface connector)

CN402 (Ink sensor connector)

Pin No.	Signal	IN/OUT	Function
1	INK_PWM	OUT	Ink sensor photo LED drive signal
2	GND
3	INKS	IN	Voltage varies according to the degree of reflected light

CN501 (DC power connector)

Pin No.	Signal	IN/OUT	Function
1	+5V	IN	+5VDC
2	+5V-GND	...	GND
3	VH	IN	+19V
4	VH-GND	...	GND
5	VM	IN	+27VDC
6	VM-GND	...	GND
7	PW_COT	OUT	Power output voltage (HVH,VM) control signal

CN502 (Paper feed motor connector)

Pin No.	Signal	IN/OUT	Function
1	LFA	OUT	Paper-feed motor phase A
2	LFB	OUT	Paper-feed motor phase B
3	LFA	...	Paper-feed motor phase A
4	VSEN	OUT	LF encoder sensor power source
5	LFB	OUT	Paper-feed motor phase B

CN503 (Pump sensor connector) / Carriage motor connector

Pin No.	Signal	IN/OUT	Function
1	VSEN	OUT	Ink sensor photo LED drive signal
2	GND
3	SNS_PG	IN	Pump sensor sense signal High (sense)/Low
4	CRA	OUT	Carriage motor phase A
5	CRB	OUT	Carriage motor phase B

CN505 (ASF motor connector)

Pin No.	Signal	IN/OUT	Function
1	ASFA	OUT	ASF motor phase A
2	ASFB	OUT	ASF motor phase B
3	$\overline{\text{ASFA}}$	OUT	ASF motor phase $\overline{\text{A}}$
4	$\overline{\text{ASFB}}$	OUT	ASF motor phase $\overline{\text{B}}$

CN506 (Purge motor connector)

Pin No.	Signal	IN/OUT	Function
1	COM	...	Common terminal
2	PGA	OUT	Purge motor phase A
3	$\overline{\text{PGA}}$	OUT	Purge motor phase $\overline{\text{A}}$
4	PGB	OUT	Purge motor phase B
5	$\overline{\text{PGB}}$	OUT	Purge motor phase $\overline{\text{B}}$

1.2 Carriage Board

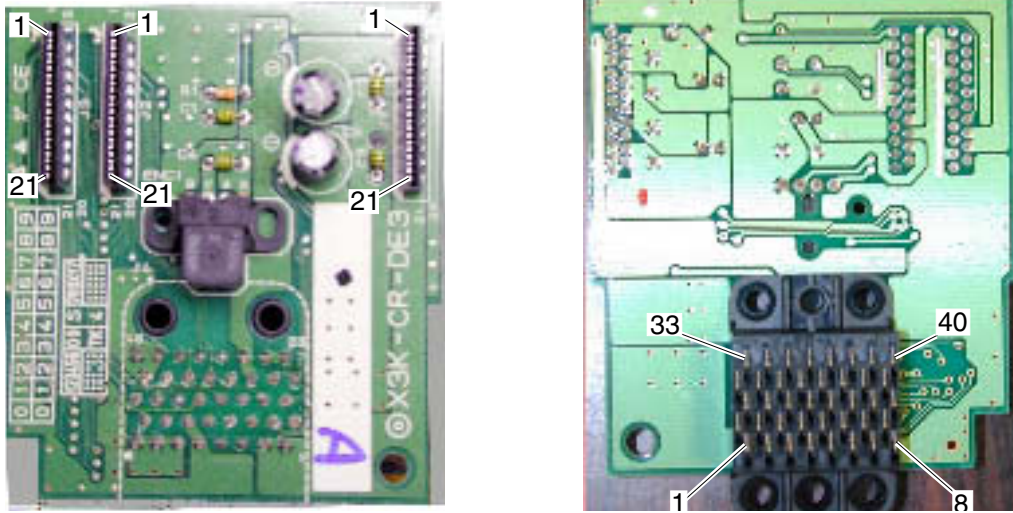

Figure 4-8 Carriage Board

J1 (Carriage flexible cable connector)

See page 4-11 (CN201 Carriage flexible cable connector pin description)

J2 (Carriage flexible cable connector)

See page 4-11 (CN202 Carriage flexible cable connector pin description)

J3 (Carriage flexible cable connector)

See page 4-12 (CN203 Carriage flexible cable connector pin description)

J4 (Print head)

Pin No.	Signal	IN/OUT	Function
1~40			<i>See page 4-15 (Print head pin description)</i>

1.3 Print Head

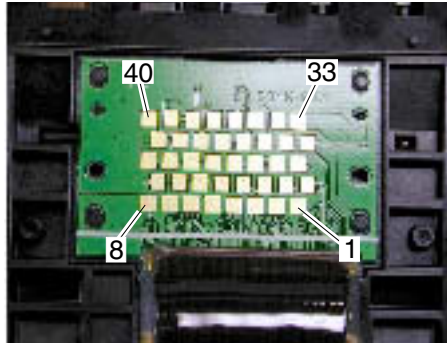

Figure 4-9 Print Head

Pin No	Signal	IN/OUT	Function
1,2	A_GND	...	GND (for black heater driving voltage)
3	H_D2	IN	Cyan even array nozzle data signal
4	H_D6	IN	Yellow even array nozzle data signal
5, 14, 22			
6, 7, 8	B_GND	...	GND (for color heater driving voltage)
9	DIK0	OUT	Head temperature sensor's (diode) cathode side (black)
10	SUBH0	IN	Black secondary heater driving voltage
11	H_D4	IN	Magenta even array nozzle data signal
12	H_ENB1	IN	Color nozzle heat enable signal (Even/odd array odd block)
13	N.C		
15	H_D5	IN	Magenta odd array nozzle data signal
16	DIK1	...	Head temperature sensor's (diode) cathode side (color)
17	H_D0	IN	Black even array nozzle data signal
18	H_ENB0	IN	Black nozzle heat enable signal
19	N.C		
20	H_LATCH	IN	Data latch enable signal
21	SUBH0	IN	Color secondary heater driving signal
23	H_D7	IN	Yellow odd array nozzle data signal
24	H_ENB2	IN	Color nozzle heat enable signal (Even/odd array's even block)
25	H_D1	IN	Black odd array nozzle data signal
26	DIA0	OUT	Black
27, 35	HVDD	IN	Logic power source
28	H_EEPROM_CS	IN	Head EEPROM chip select signal
29	H_CLK	IN	Clock signal
30	E_D0	OUT	Head EEPROM output data signal
31	H_D3	IN	Cyan odd array nozzle data signal
32, 40	B_VH	IN	Color heater driving voltage
33, 34	A_VH	IN	Black heater driving voltage
36	H_EEPROM_SK	IN	Head EEPROM serial data clock signal
37	E_DI	IN	Head EEPROM input data signal
38	DIA1	OUT	Head temperature sensor's (diode) anode side (color)
39	VHT	IN	Head power transistor driving power source

1. CONNECTOR LOCATIONS AND PIN CONFIGURATIONS

1.1 Logic Board

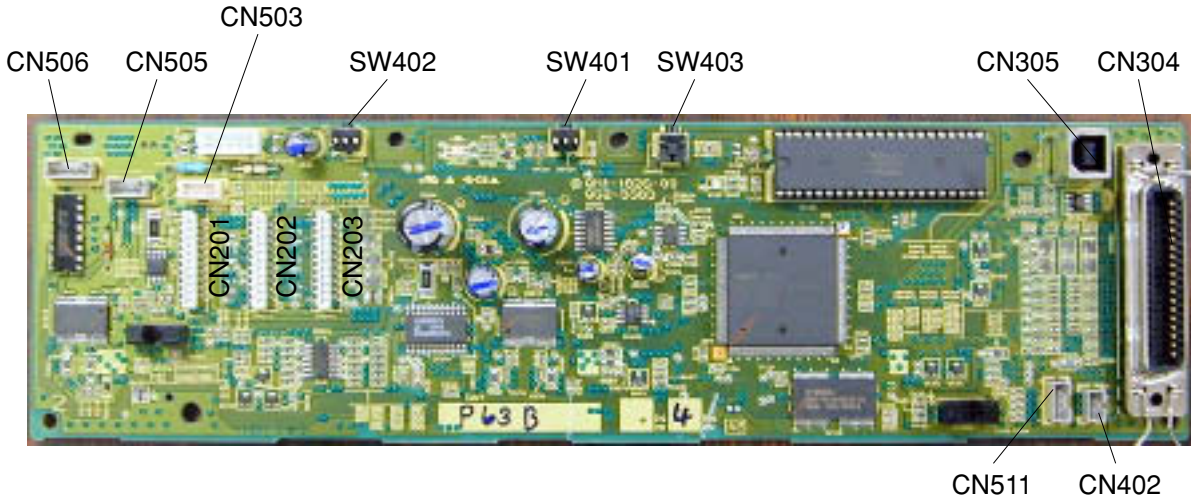

Figure 4-10 Logic Board

CN201 (Carriage flexible cable connector) ↔ J1 : Carriage board

Pin No.	Signal	IN/OUT	Function	J1 Pin No.
1	VHT	OUT	Head power transistor driving power source (19V)	Same as CN201 pin no.s
2~6	B_VH	OUT	Color heater driving voltage (19 V)	
7~11	A_VH	OUT	Black heater driving voltage (19 V)	
12~16	B_GND	...	GND (for color heater driving voltage)	
17~21	A_GND	...	GND (for black heater driving voltage)	

CN202 (Carriage flexible cable connector) ↔ J2 : Carriage board

Pin No.	Signal	IN/OUT	Function	J2 Pin No.
1, 2, 3, 7, 9, 11 14, 16, 19	SUBH0 GND	OUT ...	Black secondary heater driving signal Logic ground	Same as CN202 pin no.s
4	H_ENB1	OUT	Color nozzle heat enable signal (Even/odd array's odd block)	
5	H_ENB2	OUT	Color nozzle heat enable signal (Even/odd array's even block)	
6	H_ENB0	OUT	Black nozzle heat enable signal	
8	H_LATCH	OUT	Data latch enable signal	
10	H_CLK	OUT	Clock signal	
12	H_D0	OUT	Black even array nozzle data signal	
13	H_D1	OUT	Black odd array nozzle data signal	
15	ENCA	IN	Carriage encoder signal	
17	ENCB	IN	Carriage encoder signal	
18	VSEN	OUT	Carriage encoder sensor power source	
20	DIA0	IN	Head temperature sensor's (diode) anode side (black)	
21	DIK0	...	Head temperature sensor's (diode) cathode side (black)	

CN203 (Carriage flexible cable connector) ↔ J3 : Carriage board

Pin No.	Signal	IN/OUT	Function	J3 Pin No.
1, 2	SUBHO	OUT	Color secondary heater driving signal	Same as CN203 pin no.s
3, 7, 11, 19	GND	...	Logic ground	
4	H_D2	OUT	Cyan even array nozzle data signal	
5	H_D3	OUT	Cyan odd array nozzle data signal	
6	H_D4	OUT	Magenta even array nozzle data signal	
8	H_D5	OUT	Magenta odd array nozzle data signal	
9	H_D6	OUT	Yellow even array nozzle data signal	
10	H_D7	OUT	Yellow odd array nozzle data signal	
12	H_EEPROM_CS	OUT	Print head EEPROM chip select signal	
13	H_EEPROM_SK	OUT	Print head EEPROM serial data clock signal	
14	H_EEPROM_D	OUT	Print head EEPROM serial data signal in the print head	
15~18	HVDD	OUT	Print head logic power source	
20	DIA1	IN	Head temperature sensor's (diode) anode side (color)	
21	DIK1	...	Head temperature sensor's (diode) cathode side (color)	

CN304 (Parallel interface connector)

See page 4-6 (S820 JIF1 parallel interface connector)

CN305 (USB interface connector)

See page 4-1 (S900 JUSB1 USB interface connector)

CN402 (Ink sensor connector)

Pin No.	Signal	IN/OUT	Function
1	INK_PWM	OUT	Ink sensor photo LED drive signal
2	GND
3	INKS	IN	Voltage varies according to the degree of reflected light

CN501 (DC power connector)

Pin No.	Signal	IN/OUT	Function
1	+5V	IN	+5VDC
2	+5V-GND	...	GND
3	VH	IN	+19V
4	VH-GND	...	GND
5	VM	IN	+27VDC
6	VM-GND	...	GND
7	NC	...	NC

CN503 (Pump sensor connector) / Carriage motor connector

Pin No.	Signal	IN/OUT	Function
1	VSEN	OUT	Ink sensor photo LED drive signal
2	GND
3	SNS_PG	IN	Pump sensor sense signal High (sense)/Low
4	CRA	OUT	Carriage motor phase A
5	CRB	OUT	Carriage motor phase B

CN505 (ASF motor connector)

Pin No.	Signal	IN/OUT	Function
1	ASFA	OUT	ASF motor phase A
2	ASFB	OUT	ASF motor phase B
3	ASFA̅	OUT	ASF motor phase A̅
4	ASFB̅	OUT	ASF motor phase B̅

CN506 (Purge motor connector)

Pin No.	Signal	IN/OUT	Function
1	COM	...	Common terminal
2	PGA	OUT	Purge motor phase A
3	PGA̅	OUT	Purge motor phase A̅
4	PGB	OUT	Purge motor phase B
5	PGB̅	OUT	Purge motor phase B̅

CN511 (Paper feed motor connector)

Pin No.	Signal	IN/OUT	Function
1	LFA	OUT	Paper-feed motor phase A
2	LFB	OUT	Paper-feed motor phase B

1.2 Carriage Board

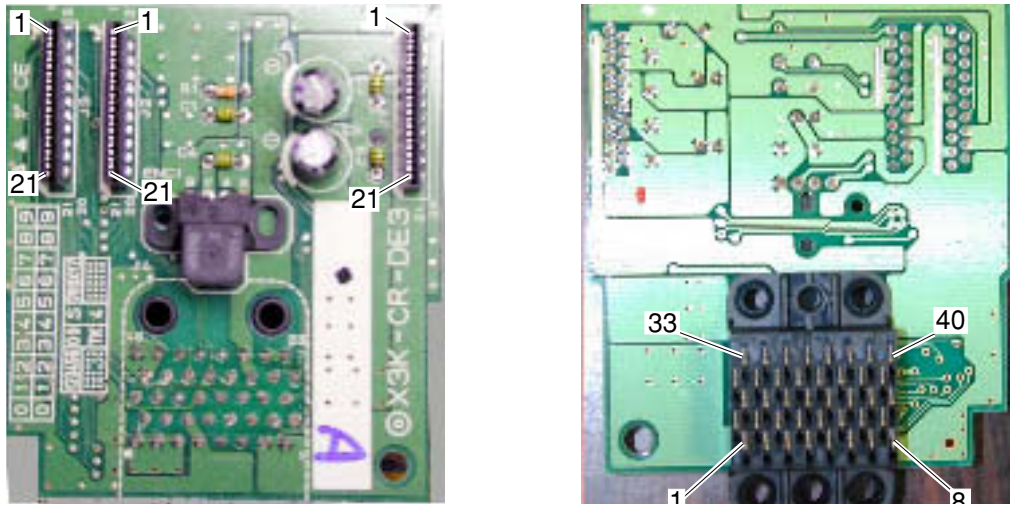

Figure 4-11 Carriage Board

J1 (Carriage flexible cable connector)

See page 4-16 (CN201 Carriage flexible cable connector pin description)

J2 (Carriage flexible cable connector)

See page 4-16 (CN202 Carriage flexible cable connector pin description)

J3 (Carriage flexible cable connector)

See page 4-17 (CN203 Carriage flexible cable connector pin description)

J4 (Print head)

Pin No.	Signal	IN/OUT	Function
1~40			<i>See page 4-20 (Print head pin description)</i>

Appendix

1.3 Print Head

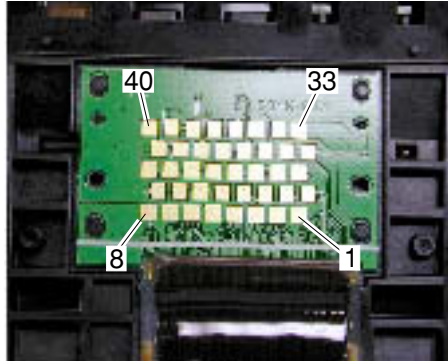

Figure 4-12 Print Head

Pin No	Signal	IN/OUT	Function
1,2	A_GND	...	GND (for black heater driving voltage)
3	H_D2	IN	Cyan even array nozzle data signal
4	H_D6	IN	Yellow even array nozzle data signal
5, 14, 22			
6, 7, 8	B_GND	...	GND (for color heater driving voltage)
9	DIK0	OUT	Head temperature sensor's (diode) cathode side (black)
10	SUBH0	IN	Black secondary heater driving voltage
11	H_D4	IN	Magenta even array nozzle data signal
12	H_ENB1	IN	Color nozzle heat enable signal (Even/odd array odd block)
13	N.C		
15	H_D5	IN	Magenta odd array nozzle data signal
16	DIK1	...	Head temperature sensor's (diode) cathode side (color)
17	H_D0	IN	Black even array nozzle data signal
18	H_ENB0	IN	Black nozzle heat enable signal
19	N.C		
20	H_LATCH	IN	Data latch enable signal
21	SUBH0	IN	Color secondary heater driving signal
23	H_D7	IN	Yellow odd array nozzle data signal
24	H_ENB2	IN	Color nozzle heat enable signal (Even/odd array's even block)
25	H_D1	IN	Black odd array nozzle data signal
26	DIA0	OUT	Black
27, 35	HVDD	IN	Logic power source
28	H_EEPROM_CS	IN	Head EEPROM chip select signal
29	H_CLK	IN	Clock signal
30	E_D0	OUT	Head EEPROM chip select signal
31	H_D3	IN	Cyan odd array nozzle data signal
32, 40	B_VH	IN	Color heater driving voltage
33, 34	A_VH	IN	Black heater driving voltage
36	H_EEPROM_SK	IN	Head EEPROM serial data clock signal
37	E_DI	IN	Head EEPROM input data signal
38	DIA1	OUT	Head temperature sensor's (diode) anode side (color)
39	VHT	IN	Head power transistor driving power source

2. PROBLEMS LEFT REMAINING

S900/S9000/S820 issues	Issue	Model	Cause	Countermeasure	Remarks
	<u>Repeating feed failure of all sizes of PC101</u> Occurs only in L/L environment. Extremely low occurrence rate.	All	There is insufficient contact between the feed roller and the separation pad, and if self-cleaning is not performed to remove paper dust on the rubber of the roller, the friction coefficient is lowered.	When feeding problems (including repeating failure) occur, perform feed roller cleaning 2 times. (Note that excessive cleaning will wear out the rollers)	
	<u>Edge of the page contacts head</u> The leading or trailing edge of the paper contacts the head and leaves black traces. 1) Occurs with borderless paper Misaligned printing may affect postcards. 2) Occurs with non-borderless normal and HG-201 paper Problem occurs with HG-201 even when the paper lever is set to envelope thickness. Note that there is no problem printing within the recommended print area of non-borderless paper.	All	(1) Due to the elimination of the paper depressor of models to date in order to allow borderless printing. (2) Paper curling (especially HG-201 after printing)	1) Paper which supports borderless printing. * Have the user understand that there is the possibility of ink stains at the leading and trailing edges when borderless printing. * Flatten curled paper. * Set the paper thickness lever to envelope thickness. Recommend non-borderless printing with the recommended print area. Have the user understand that although borderless printing is possible with normal paper, it is not recommended.	
	<u>Inappropriate color hues at quality settings of 1 (highest quality) and 2 (high quality)</u> Conspicuous with grey, barely noticeable with other colors. Problem papers are GP301, HR101.	All	Quality settings 2 (4 pass, uni-directional) and 1 (8 pass, bi-directional) use the same color parameters.	As per specifications.	
	<u>In the borderless printing durability test, staining of the reverse side of the paper occurred. The right side ribs cannot be cleaned.</u> Occurs at a low level when more than 3000 sheets (1000 borderless postcards) but, at an unacceptably high level when 6000 sheets (2000 borderless postcards) are fed. This problem will only begin to affect the average user (300 postcards per year) after 4 years or so, and so is not a major issue	All	Paper dust which absorbs ink particles accumulates on the platen ribs and causes staining. There are two causes: (1) Significant paper dust accumulates from factory sizing of Japanese postcards and KH201. (2) Ink mist attaches easily to paper edges.	Cleaning method for after borderless printing or the platen has been printed (purge side of the platen): 1. Power the printer ON and open the access cover. 2. With the head at replacement position, remove the power cord. 3. Clean the purge-side platen ribs with Q-tips etc.	

When borderless printing on normal paper, the trailing edge of the paper contacts the platen absorber and stains the printout.	All	The distance between the platen rib surface and the platen absorber is too narrow for paper curling during printing. As such, during borderless printing the trailing edge of the paper may fall into the channel and come in contact with the absorber.	Have the user understand that although borderless printing is possible with normal paper, it is not recommended.
Uneven density due to sudden release of trailing edge from roller Barely perceptible with normal images. Postcard leading edge curl	All	Uneven density due to feeding, when the paper is released by the pinch roller.	As per specifications.
Occurs when printing the address side of the card after borderless printing the other side. Conspicuous with IJ postcards, but also occurs with government issue postcards and KH201 although barely perceptible.	All	There is friction with the leading edge at the ASF separation pad when feeding. As such, when the address side is printed after the reverse has already been printed the leading edge tends to curl.	When there are problems with leading edge curl, print the address side of the card first.
When borderless printing, uneven print density occurs about 4mm from the trailing edge. Occurs with PR101 and the pattern for checking striping and uneven density. Barely perceptible with normal images.	All	Based on the amount of curling due to printing, when printing the end of the trailing edge it falls into the platen channel. If the paper thickness lever is adjustment, dot placement is affected.	As per specifications.
When using VIVID Photo, uneven color can occur in areas of high density Problem occurs almost solely with solid dark color, such as images of night sky.	All	Possibility that this problem occurs due to digital camera (etc.) CCD noise.	If this is a problem, advise against use of VIVID Photo. (VIVID Photo is default OFF).

Other:

1) The occurrence rate of the following problems is very low, and they can be recovered by normal cleaning:

- * Color mixing (a issue mainly with yellow).
 - * Non-ejection (one color of ink is suddenly not ejected)
 - * Ink smearing (ink concentrations on the face results in long smears on the paper surface)
- 2) About throughput:
- * Throughput is lowered during borderless printing -> since the number of nozzles used to print the leading and trailing edges is limited.
 - * Throughput is lowered during quiet mode -> since paper feeding operations are conducted slower.

S750/S520 issues

Issue	Model	Cause	Countermeasure	Remarks
The volume of operation noise in Draft mode is high.	BJ S750	The movement of the pressure plate during normal feeding operation is noisy. Improvements in speed have increased the speed of pressure plate operation and related noise levels.	(1) Change the print quality setting from Draft to Standard. The throughput is lowered. Bk: 20 -> 12 ppm, Ci: 13 -> 8 ppm (2) Use Quiet mode. Throughput is lowered.	
When printing the address side of KH201, multiple sheets are fed simultaneously in Quiet mode. Conditions: High temperature, high humidity only.	BJ S750	When the address side of the paper is printed after having already printed the reverse, the moisture of that side increases its friction coefficient with other sheets and they are fed together.	When this problem occurs, switch from Quiet to Standard mode.	
In areas of high density, the image is degraded	BJ 750	In order to improve color density, the ink ejection amount ink has been increased.	In the driver properties, change the brightness in the color adjustment settings from Normal to Light.	
A whiteness appears where seams of color and black printing join	BJ 750	Color areas lying next to sections of solid black ink lower the density of the black ink, causing this problem. When the density of black ink on the page is high, and the time before color ink is printed next to it is short, this problem is likely to occur. Paper type and image are also factors.	(1) Raise the print quality (this increases the number of passes and lengthens the time between ejection of color and black inks) Throughput is lowered. (2) Use a paper not conducive to bleeding.	
When cancelling a print job, printing continues even as "Printer not responding" is displayed. (Win2000/XP only)	BJ 750	Even though the printer receives the cancel signal, while a job is being cancelled the status cannot be freed up.	None.	As to date, ROM version will be upgraded.
When printing on normal paper in High quality mode, bleeding of black ink is even worse than with the S500 model.	S520	Due to the increase of the color ink ejection amount.	None.	See information for overseas.
Borderless printing on GP301 results in friction with the head.	All	(1) Curled paper cannot be depressed properly by the eject roller. (2) There is no paper depressor on the left side of the printer.	When there is friction with the head, move the paper thickness lever to the envelope position. A display will appear indicating that the lever is not set to the correct position. The accuracy of dot placement will be affected, lowering print quality (S750)	Even if paper impacts against the head, the head will not suffer damage.
When printing the address side of postcards after having already printed the reverse, the trailing edge of the paper may hit the head. Conditions: Low temperature, low humidity only.	All	(1) The paper curls after printing the reverse of the address side. (2) There is no paper depressor on the left side of the printer.	Flatten out the postcard, or print the address side first.	The S900/S820 do not have this problem due to differing ink ejection amounts meaning different degrees of paper curling.

<p>Ink may seep through when printing both sides of very thin paper.</p>	<p>All</p>	<p>Due to the increase of the color ink ejection amount for better color density.</p>	<p>Set the mode to Draft and the problem can be avoided by the lower ink ejection amount. Print quality will be lowered.</p>	
<p>Specific problems with SOTEC PCs</p>	<p>All</p>	<p>SOTEC e-note M260TX3 (on sale since Sep. 2000) However connections are made, ECP communication errors occur. Issue (1) According to the communication error, the printer will display "Printer not responding". Issue (2) Data corruption Conditions: * PC SOTEC e-note M260TX3 (chipset: SIS630, WindowsMe) * PC BIOS ECP Setting * Printer utility ECP setting</p>	<p>(1) Use USB rather than parallel interface to connect. (2) If problems occur, turn the ECP setting off. The throughput may be lowered.</p>	<p>Affected models: Issue (1): S600/S630/S6300 (previous models only) Issue (2): S600/S630/S6300/S800 (previous models), and S750/S520</p>
<p>Non-ejection of black ink</p>	<p>All</p>	<p>If black ink tanks are left installed for a lengthy period of time, the contents settle and the density of the ink in the lower part of the tanks increases, causing clogging in the head. Bk: 20 -> 5 ppm, Cl: 13 -> 4.6 ppm</p>	<p>Perform Deep Cleaning (2 or 3 times may be necessary)</p>	
<p>Lower throughput in Quiet Mode</p>	<p>BJ S700</p>	<p>With PR101, 0.51 ppm -> 0.45 ppm</p>	<p>As per specifications</p>	
<p>Lowered throughput when borderless printing</p>	<p>All</p>		<p>As per specifications.</p>	

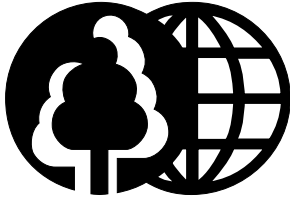

The printing paper contains
100% waste paper.

Canon