

EPSON **AcuLaser**[™]
C2000

UNPACKING GUIDE

English

Deutsch

Français

Español

Italiano

Português

1 Unpacking

1. Open the top of the large box.
2. Take out the waste toner collector and the document box.

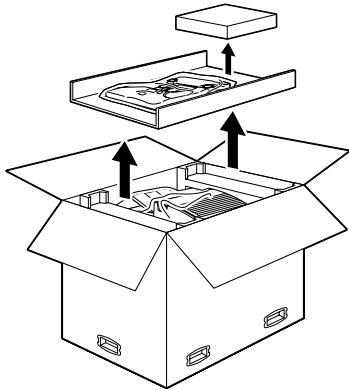

3. Take out the rectangular box from the top of the large box and remove the protective materials.

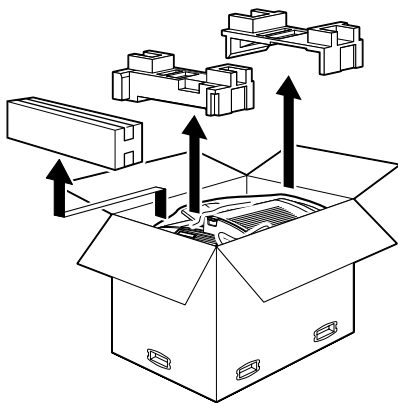

4. Pull away the six clips from the large box, then lift the upper part of the box and remove it from the bottom part.

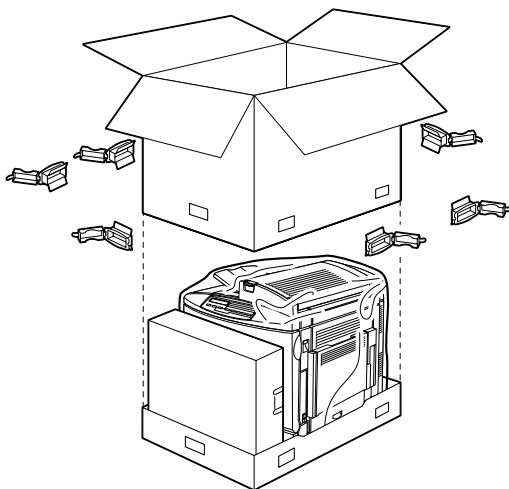

5. Carefully take out the remaining box from the side and place it on a stable surface.

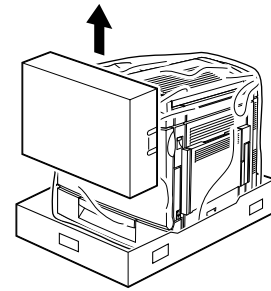

6. Lift up and remove the printer from the box.



Caution:

- ❑ The printer weighs about 39.5 kg (87 lb); always lift it with two or more people.
- ❑ Hold the printer at the locations indicated below.

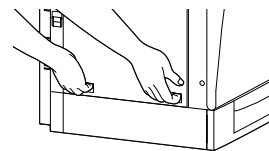

left side

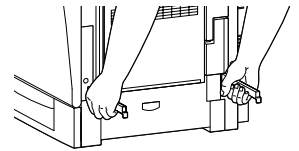

right side

7. Open all the boxes and make sure you have everything shown below.

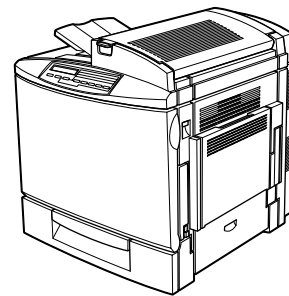

printer



document box

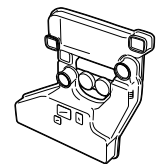

waste toner collector

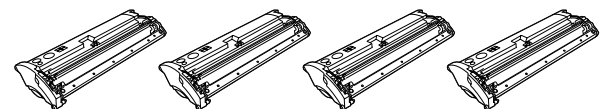

developer cartridges (Yellow, Magenta, Cyan, and Black)

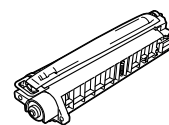

photoconductor unit

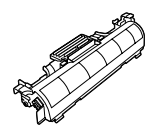

fuser oil roll

Note:

- ❑ If a power cord is included in your area, it is packed either in the large box with the printer, or in the document box, depending on your location.
 - ❑ The shape of the power cord plug varies by country; be sure the plug is of the right shape for your location.
 - ❑ In some locations, a ground wire is included with the printer.
8. Before you start using the printer, you have to remove all the protective materials shown in the illustrations below.

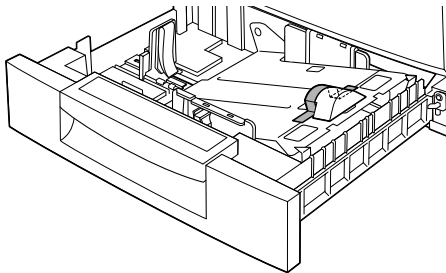
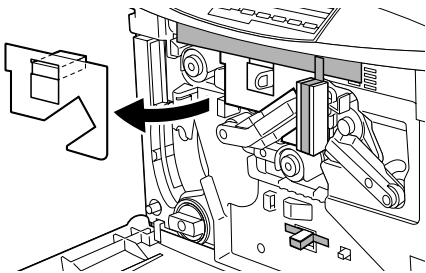
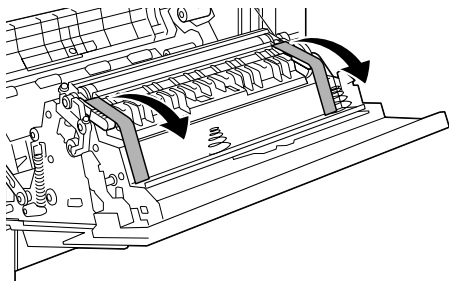
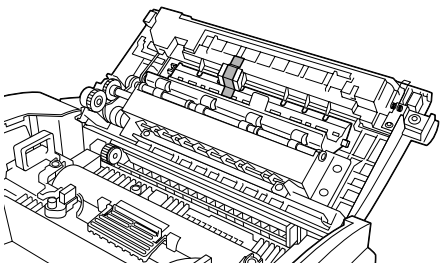
**2 Finding a place for the printer**

Allow adequate space for easy operation and maintenance as shown below.

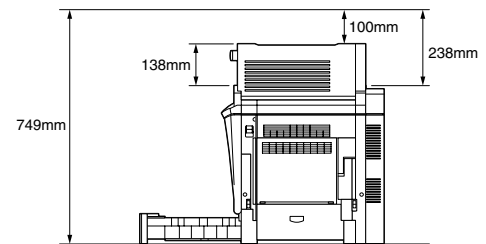
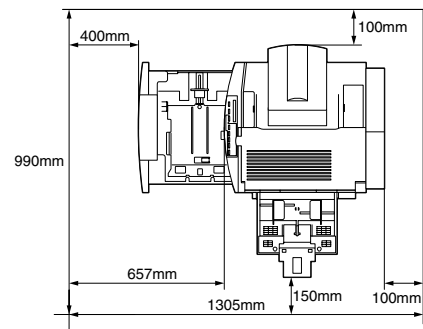

To install any of the following options, you will need the indicated amount of additional space.

The **500-Sheet Paper Cassette Unit** adds 114 mm (4.9 in.) to the bottom of the printer.

The **Duplex Unit** adds 33 mm (1.3 in.) to the right side of the printer.

In addition to space consideration, always heed the following precautions when finding a place to locate the printer:

- ❑ Place the printer where you can easily unplug the power cord.
- ❑ Keep the entire computer and printer system away from potential sources of interference, such as loudspeakers or the base units of cordless telephones.
- ❑ Avoid using an electrical outlet that is controlled by wall switches or automatic timers. Accidental disruption of power can erase valuable information in your computer's and printer's memory.

**Caution:**

Make sure you have removed all protective tape from the various parts of the printer.



Caution:

- ❑ *Leave adequate room around the printer to allow for sufficient ventilation.*
- ❑ *Avoid locations that are subject to direct sunlight, excessive heat, moisture, or dust.*
- ❑ *Avoid using outlets that other appliances are plugged into.*
- ❑ *Use a grounded outlet that matches the printer's power plug. Do not use an adapter plug.*
- ❑ *Only use an outlet that meets the power requirements for this printer.*

1 Drucker auspacken

1. Öffnen Sie den Deckel des großen Kartons.
2. Nehmen Sie den Tonerauffangbehälter und den Karton mit der Dokumentation aus dem großen Karton heraus.

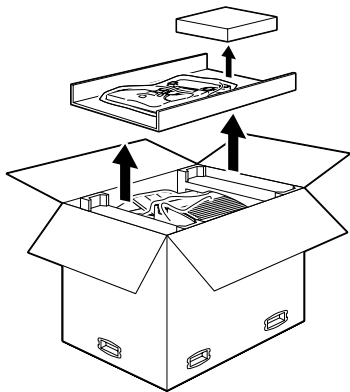

3. Nehmen Sie den rechteckigen Karton aus dem großen Karton heraus, und entfernen Sie das Verpackungsmaterial.

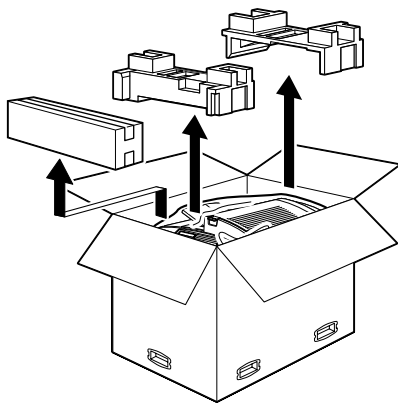

4. Entfernen Sie die sechs Clips vom großen Karton, heben Sie den oberen Teil des Kartons an, und ziehen Sie ihn vom unteren Teil ab.

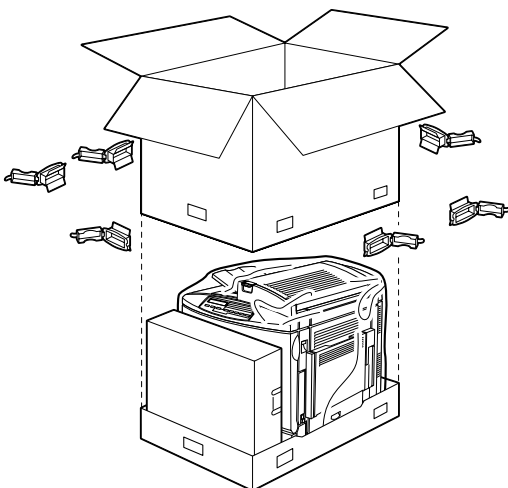

5. Nehmen Sie vorsichtig den letzten Karton seitlich aus dem großen Karton heraus, und stellen Sie ihn auf eine stabile Fläche.

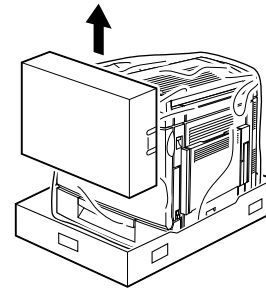

6. Nehmen Sie den Drucker aus dem Karton heraus.



Achtung:

- ❑ Der Drucker wiegt ca. 39,5 kg und sollte immer von mindestens zwei Personen getragen werden.
- ❑ Halten Sie den Drucker an den unten gezeigten Stellen.

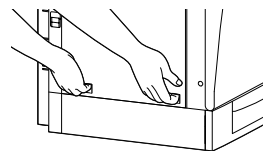

Linke Seite

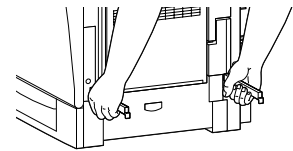

Rechte Seite

7. Öffnen Sie alle Kartons, und stellen Sie sicher, dass alle unten abgebildeten Teile vorhanden sind.

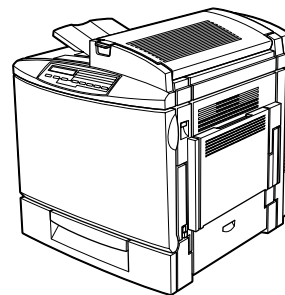

Drucker



Verpackungsbox der Dokumentation

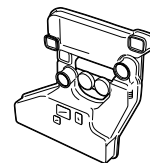

Tonerauffangbehälter

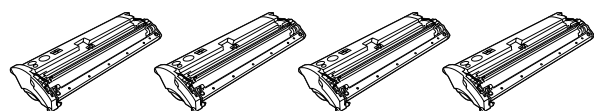

Entwicklerpatrone (Gelb, Magenta, Cyan und Schwarz)

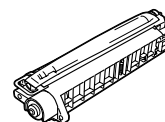

Photoleiter

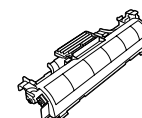

Fixieröleinheit

Hinweise:

- ❑ Wenn für Ihr Land ein Netzkabel zum Lieferumfang gehört, befindet sich dieses entweder im großen Druckerkarton oder im Karton mit der Dokumentation.
 - ❑ Das Netzkabel variiert je nach Land. Stellen Sie sicher, dass der Stecker passend für Ihr Land ist.
 - ❑ In manchen Ländern gehört auch ein Massedraht zum Lieferumfang des Druckers.
8. Bevor Sie mit dem Drucker arbeiten, müssen Sie alles Verpackungsmaterial entfernen, wie in der Abbildung unten gezeigt.

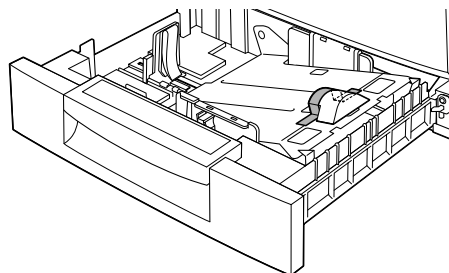
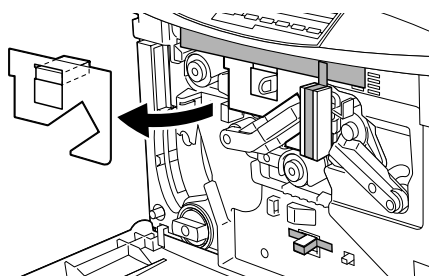
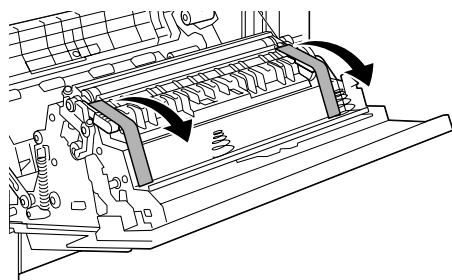
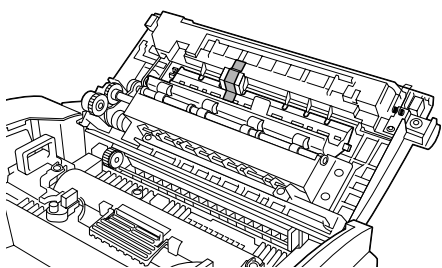

Achtung:
Stellen Sie sicher, dass Sie alle Klebestreifen vom Drucker entfernt haben.

2 Drucker aufstellen

Lassen Sie um den Drucker herum genügend Freiraum für eine bequeme Bedienung und Wartung, wie unten dargestellt.

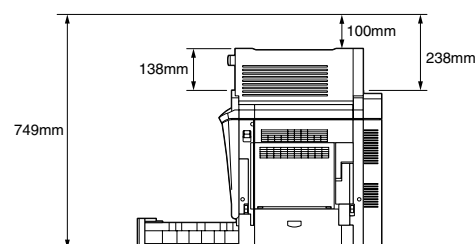
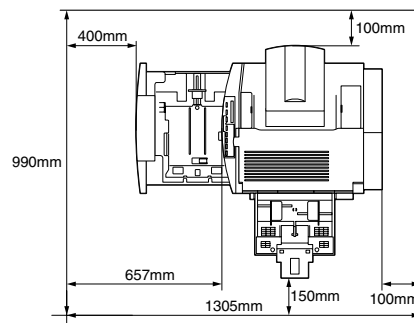

Bei Installation der Optionen benötigen Sie den folgenden zusätzlichen Freiraum.

Für das **500-Blatt-Zusatzpapiermagazin** benötigen Sie zusätzlich 114 mm unter dem Drucker.

Für die **Duplex-Einheit** benötigen Sie zusätzlich 33 mm auf der rechten Seite des Druckers.

Außerdem sollten Sie bei der Wahl des Standorts Folgendes beachten:

- ❑ Stellen Sie den Drucker so auf, dass Sie das Netzkabel bequem aus der Steckdose ziehen können.
- ❑ Stellen Sie das Drucker-Computer-System nicht in der Nähe möglicher elektromagnetischer Störfelder, wie sie z.B. durch Lautsprecher oder die Basisgeräte von Funktelefonen aufgebaut werden, auf.
- ❑ Verwenden Sie keine schaltbaren oder timergesteuerten Steckdosen, da bei einer unbeabsichtigten Stromunterbrechung alle Daten aus dem Speicher vom Drucker und Computer gelöscht werden.



Achtung:

- ❑ *Lassen Sie um den Drucker herum ausreichend Freiraum, damit für genügend Ventilation gesorgt ist.*
- ❑ *Vermeiden Sie Standorte mit direkter Sonneneinstrahlung, hohen Temperaturen oder Staubeentwicklung.*
- ❑ *Verwenden Sie keine Steckdosen, an denen bereits andere Geräte angeschlossen sind.*
- ❑ *Schließen Sie den Drucker nur an eine geerdete Steckdose an, die für den Netzstecker des Netzkabels passend ist. Verwenden Sie keinen Adapter-Stecker.*
- ❑ *Achten Sie darauf, dass die Nennspannung des Druckers mit den Spannungswerten der Steckdose übereinstimmt.*

1 Déballage

1. Ouvrez le dessus du grand carton.
2. Retirez le collecteur de toner usagé ainsi que les manuels.

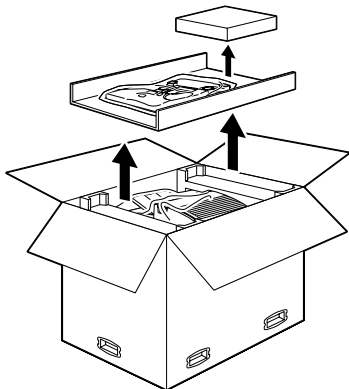

3. Retirez la boîte rectangulaire située en haut du grand carton puis retirez les matériaux de protection.

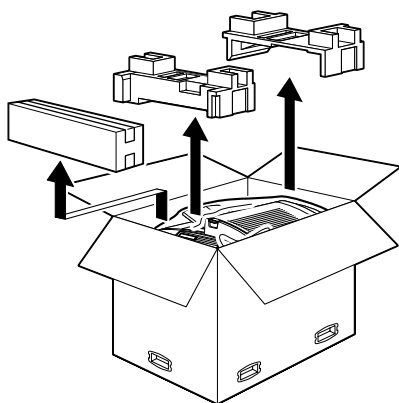

4. Dégagez les six clips du grand carton puis levez la partie supérieure du carton et retirez-la.

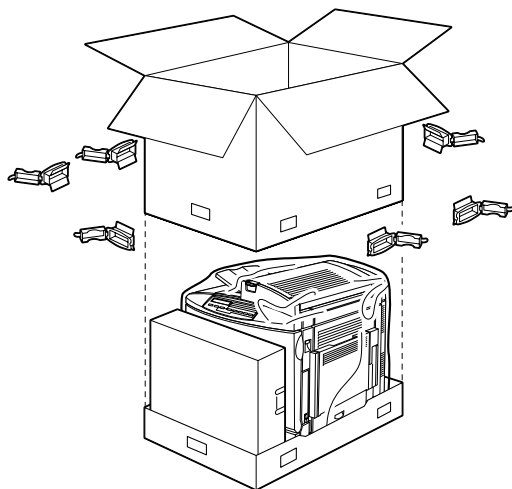

5. Retirez maintenant les côtés du carton et placez-le sur une surface plane.

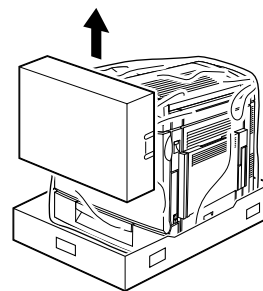

6. Soulevez et retirez l'imprimante du carton.



Attention:

- ❑ L'imprimante pèse environ 39.5 kg et l'aide de deux personnes au moins est nécessaire pour la soulever.
- ❑ Tenez l'imprimante par les endroits signalés ci-dessous.

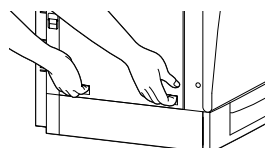

Côté gauche

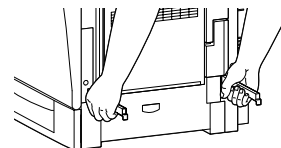

Côté droit

7. Ouvrez toutes les boîtes et vérifiez si vous avez tous les éléments présentés ci-dessous.

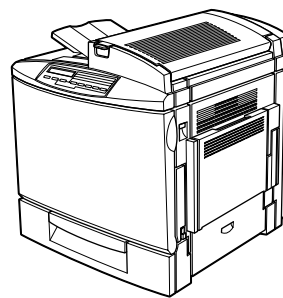

Imprimante



Boîte de documents

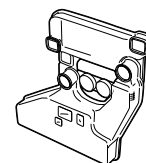

Collecteur de toner usagé

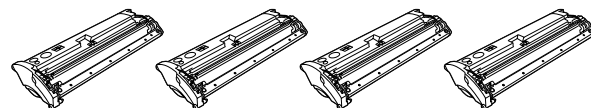

Blocs toner (Jaune, Magenta, Cyan et Noir)

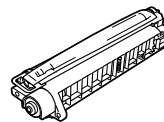

Bloc photoconducteur

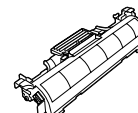

Rouleau de lubrification de l'unité de fusion

Remarque:

- ❑ Si un cordon d'alimentation est livré avec votre imprimante, il se trouve dans le grand carton de l'imprimante ou avec les manuels.
 - ❑ La forme de la prise du cordon d'alimentation est différente selon le pays. Vérifiez si elle correspond à celle utilisée dans votre pays.
 - ❑ Dans certains pays, un fil de terre est fourni avec l'imprimante.
8. Retirez tous les matériaux de protection illustrés ci-dessous avant d'utiliser l'imprimante.

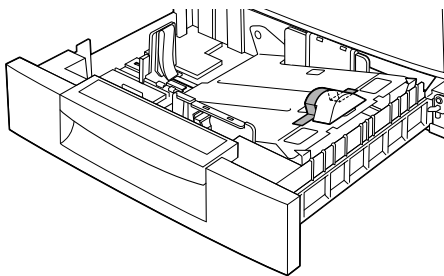
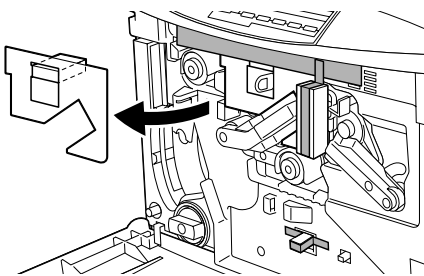
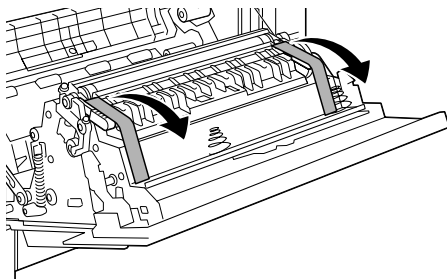
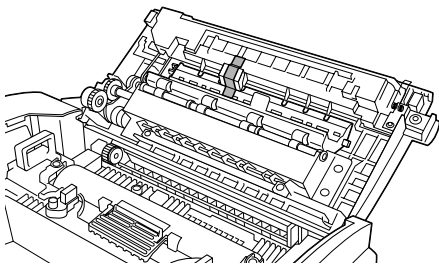

Attention:

Vérifiez si toutes les bandes adhésives ont été retirées des différents éléments de l'imprimante.

2 Choix d'un emplacement pour l'imprimante

Laissez de l'espace autour de l'imprimante afin de faciliter son fonctionnement et son entretien, comme illustré ci-dessous.

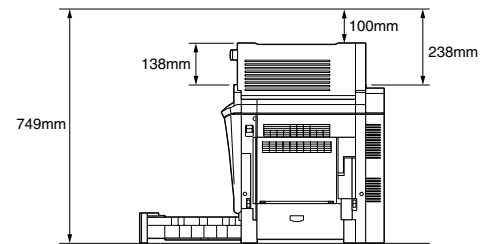
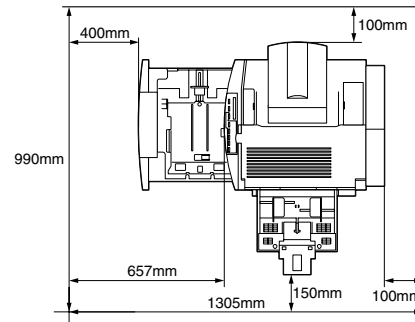

Pour installer chacune des options suivantes, vous devez disposer d'un espace supplémentaire.

Ajoutez 114 mm en bas de l'imprimante pour le **bac inférieur 500 feuilles**.

Ajoutez 33 mm à droite de l'imprimante pour l'**unité recto-verso (Duplex)**.

Outre l'espace à ajouter, les précautions suivantes sont à prendre en considération lors du choix d'un emplacement pour l'imprimante:

- ❑ Placez l'imprimante de façon à pouvoir facilement débrancher le cordon d'alimentation.
- ❑ Eloignez votre système informatique et votre imprimante des sources d'interférences potentielles, telles que les haut-parleurs ou les bases des téléphones sans fil.
- ❑ Evitez d'utiliser une prise commandée par des commutateurs.



Attention:

- ❑ *Laissez suffisamment de place autour de l'imprimante pour assurer une ventilation correcte.*
- ❑ *Évitez les emplacements soumis à la lumière directe du soleil, à des températures élevées, à l'humidité ou à la poussière.*
- ❑ *Évitez d'utiliser des prises où sont branchés d'autres appareils.*
- ❑ *Utilisez une prise de terre correspondant à la fiche secteur de votre imprimante. N'utilisez pas d'adaptateur.*
- ❑ *Utilisez uniquement une prise électrique qui réponde aux spécifications électriques de cette imprimante.*

1 Desembalaje

1. Abra la parte superior de la caja.
2. Extraiga de la caja el colector de tóner usado y la caja de la documentación.

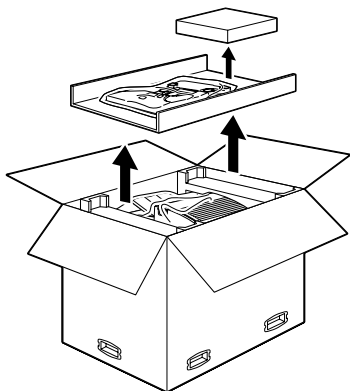

3. Extraiga la caja rectangular de la caja grande y retire los materiales de protección para el transporte.

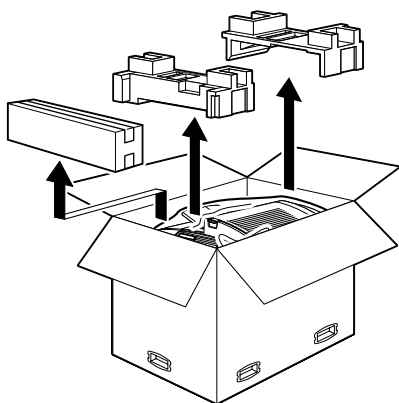

4. Retire los seis clip de la caja grande y a continuación levante la parte superior de la caja y retírela por arriba.

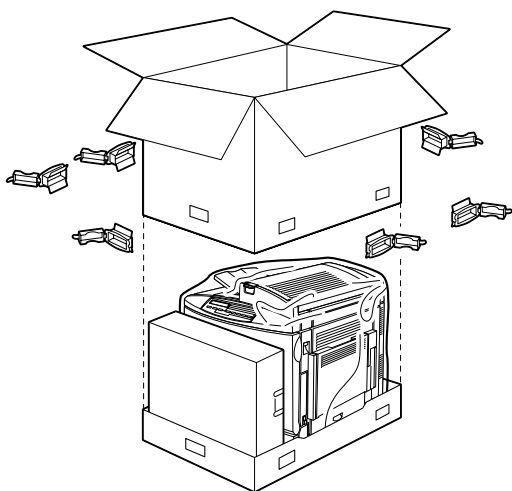

5. Extraiga la caja que queda en el lateral y colóquela sobre una superficie estable.

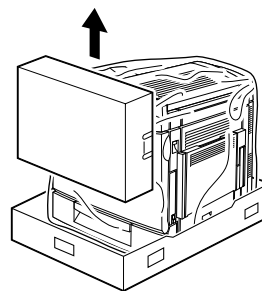

6. Extraiga la impresora de la caja.



Precaución:

- ❑ La impresora pesa unos 39.5 kg; levántela con la ayuda de dos personas más.
- ❑ Sujete la impresora por las partes indicadas en la ilustración inferior.

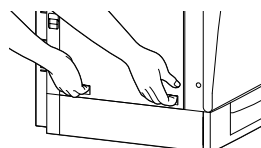

Lado izquierdo

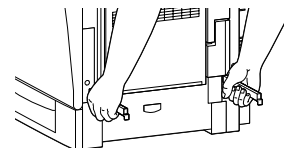

Lado derecho

7. Abra todas las cajas y compruebe que estén todos los elementos mostrados en la ilustración.

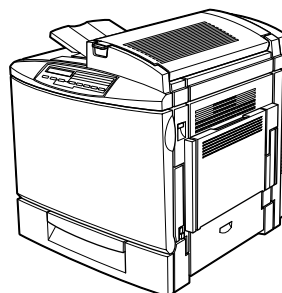

impresora

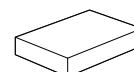

caja de documentos

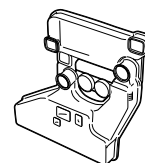

Colector de tóner usado

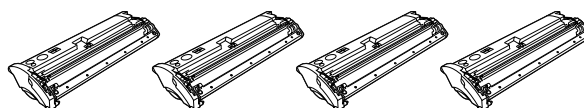

Cartuchos de tóner (Amarillo, Magenta, Cian y Negro)

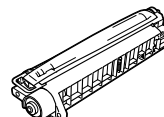

Unità fotoconduttrice

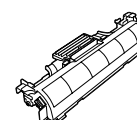

Rullo dell'olio dell'unità di fusione

Nota:

- ❑ *Dependiendo del país el cable de alimentación viene en la caja grande de la impresora o en la caja de la documentación.*
 - ❑ *La forma del enchufe del cable de alimentación varía según el país donde se va a comercializar; asegúrese de que tenga la forma adecuada para su toma de corriente.*
 - ❑ *En algunos países se incluye un cable para toma de tierra con la impresora.*
8. Antes de empezar a utilizar la impresora, retire todos los materiales de protección indicados en la ilustración.

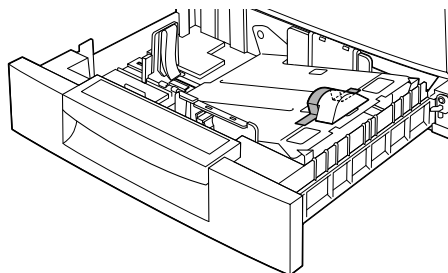
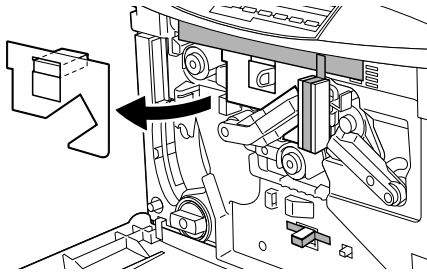
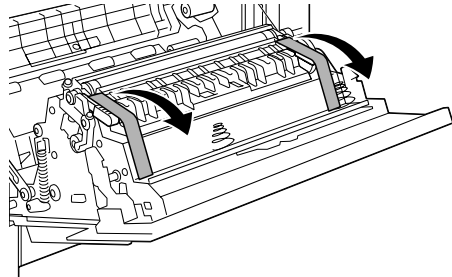
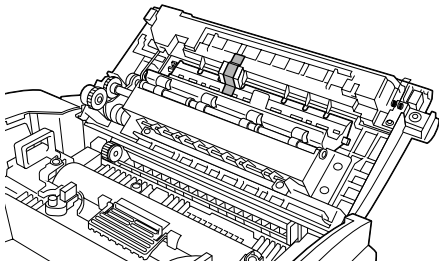

Precaución:
Asegúrese de retirar todas las cintas adhesivas de protección de la impresora.

2 Escoger un lugar para la impresora

Deje espacio suficiente para facilitar el funcionamiento y mantenimiento de la impresora.

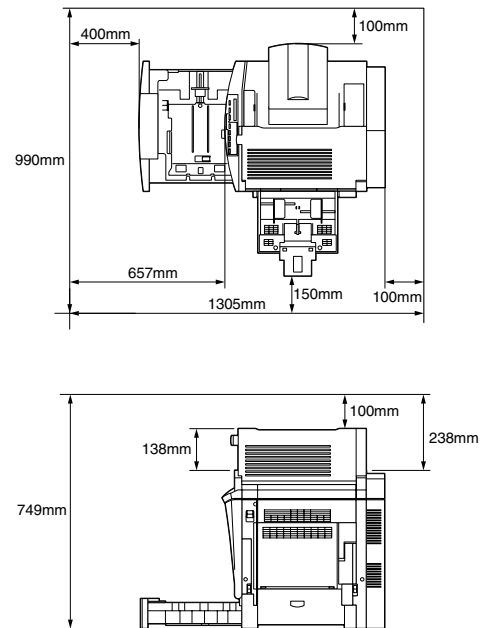

Para instalar cualquiera de las siguientes opciones, necesitará un espacio adicional.

La **Bandeja inferior de 500 hojas** añade 114 mm a la parte inferior de la impresora.

La **Unidad dúplex** añade 33 mm a la derecha de la impresora.

Además del espacio, tenga siempre en cuenta las siguientes precauciones al escoger un lugar para la impresora.

- ❑ Coloque la impresora donde pueda enchufar fácilmente el cable de alimentación.
- ❑ Mantenga su sistema (ordenador e impresora) alejado de fuentes potenciales de interferencia, como por ejemplo altavoces o unidades base de teléfonos inalámbricos.
- ❑ Evite la utilización de tomas de corriente controladas por interruptores de pared o automáticos.



Precaución:

- ❑ *Deje espacio suficiente alrededor de la impresora para permitir una correcta ventilación.*
- ❑ *Evite los lugares expuestos a la luz solar directa, sujetos a fuentes de calor excesivo o al polvo.*
- ❑ *Evite utilizar tomas de corriente donde estén conectados otros aparatos eléctricos.*
- ❑ *Utilice una toma de corriente con toma de tierra que coincida con la forma del enchufe de la impresora. No utilice adaptadores.*
- ❑ *Utilice solamente una toma de corriente que cumpla con las especificaciones eléctricas de esta impresora.*

1 Disimballaggio

1. Aprite dall'alto la scatola esterna.
2. Estraiete il collettore del toner di scarto e la scatola della documentazione.

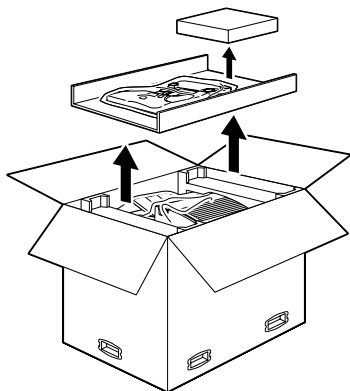

3. Estraiete la scatola rettangolare dalla scatola esterna e rimuovete il materiale protettivo.

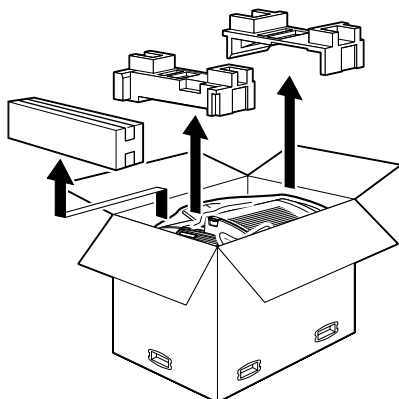

4. Tirate verso l'esterno le sei mollette dalla scatola esterna, quindi sollevate la parte superiore della scatola ed estraetela dalla parte inferiore.

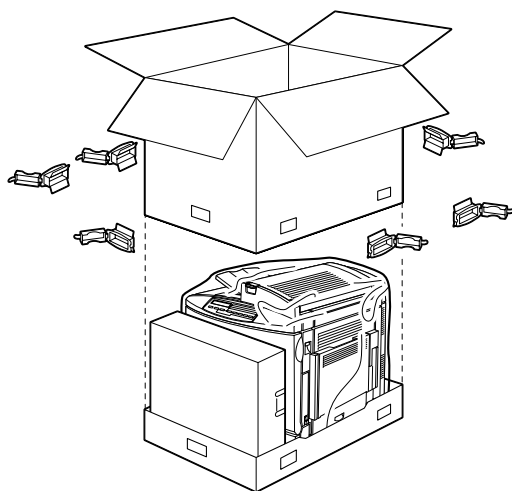

5. Estraiete lateralmente, con attenzione, la scatola rimanente e posizionatela su una superficie stabile.

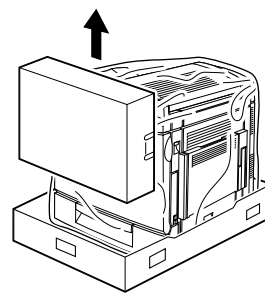

6. Sollevate ed estraete la stampante dalla scatola.



Attenzione:

❑ La stampante pesa circa 39.5 kg; sollevatela sempre in due o più persone.

❑ Reggete la stampante per gli appigli indicati in figura.

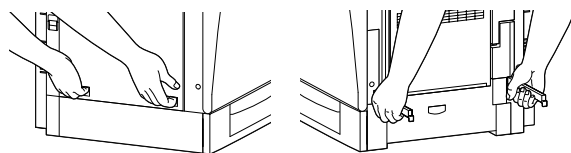

Fianco sinistro

Fianco destro

7. Aprite tutte le scatole e verificate che il contenuto coincida con quanto mostrato in figura.

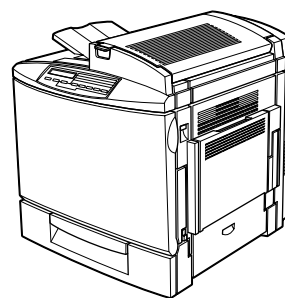

stampante

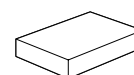

Contenitore per le istruzioni

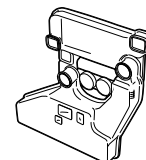

Collettore del Toner

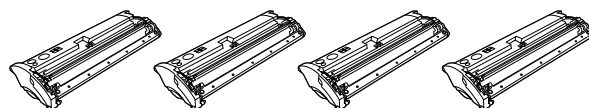

Cartucce toner (giallo, magenta, cyan e nero)

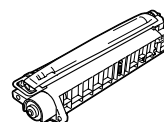

Unidad fotoconductora

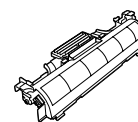

Rodillo de aceite de la unidad de fijación

Nota:

- ❑ Se nella confezione è compreso un cavo di alimentazione, questo si trova nella scatola esterna insieme alla stampante oppure nella scatola della documentazione, a seconda del paese.
 - ❑ La forma della spina del cavo di alimentazione dipende dal paese; assicuratevi che la spina sia adatta alle prese utilizzate.
 - ❑ In alcuni paesi, nella confezione è compreso un cavo di messa a terra.
8. Prima di iniziare a utilizzare la stampante dovrete rimuovere tutto il materiale protettivo mostrato in figura.

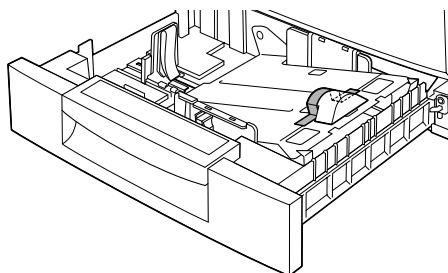
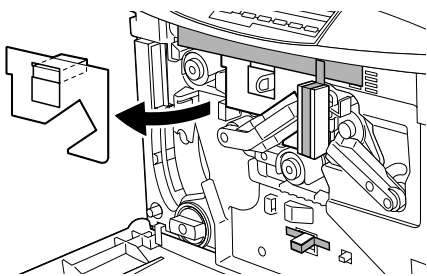
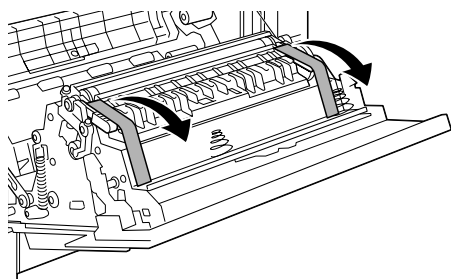
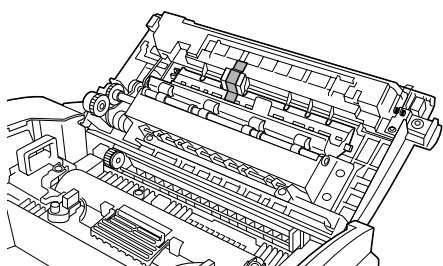

Attenzione:

Assicuratevi di aver rimosso tutto il materiale protettivo dalle singole parti della stampante.

2 Posizionamento della stampante

Lasciate spazio sufficiente intorno alla stampante per poter operare ed eseguire la manutenzione con facilità, come mostrato in figura.

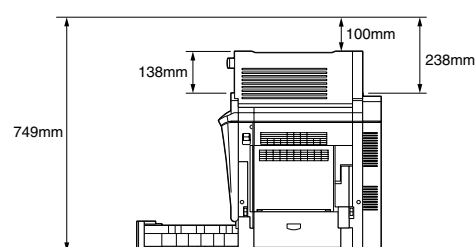
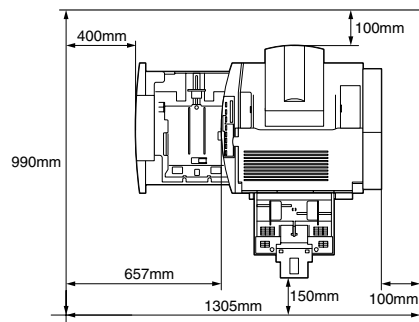

Per installare una delle seguenti opzioni avrete bisogno di ulteriore spazio intorno alla stampante, come indicato.

Per il **cassetto da 500 fogli** bisogna aggiungere 114 mm sotto la stampante.

Per l'**unità fronte/retro** bisogna aggiungere 33 mm sul lato destro della stampante.

In aggiunta allo spazio indicato, prestate sempre attenzione alle seguenti precauzioni nel posizionare la vostra stampante:

- ❑ Posizionate la stampante in modo da poter facilmente scollegare il cavo di alimentazione.
- ❑ Tenete l'intero sistema (computer e stampante) lontano da potenziali fonti di interferenza, come altoparlanti e basi di telefoni cordless.
- ❑ Evitate di usare prese elettriche controllate da timer o da interruttori a parete.



Attenzione:

- ❑ *Lasciate sempre sufficiente spazio intorno alla stampante per una ventilazione adeguata.*
- ❑ *Evitate luoghi colpiti dalla luce diretta del sole o soggetti a eccessiva temperatura, a polvere o a umidità.*
- ❑ *Evitate di usare prese elettriche condivise con altre apparecchiature.*
- ❑ *Usate una presa dotata di messa a terra compatibile con la spina del cavo di alimentazione; non usate un adattatore.*
- ❑ *Usate solo prese di rete compatibili con le specifiche elettriche della stampante.*

1 Desembalagem

1. Abra o topo da caixa grande.
2. Retire a caixa de toner residual e a caixa da documentação.

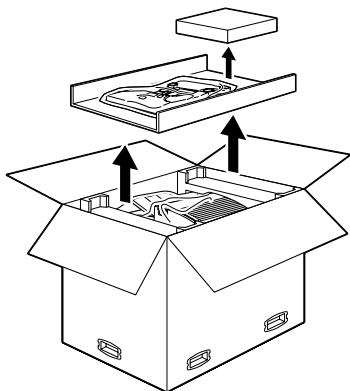

3. Retire a caixa rectangular do topo da caixa grande e retire os materiais de protecção.

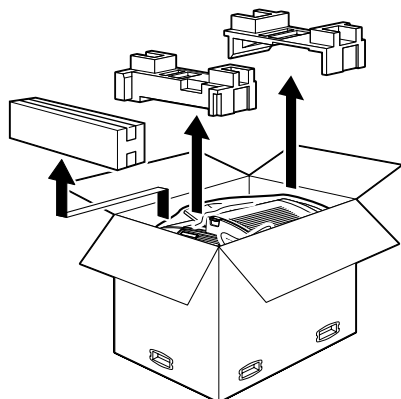

4. Retire os seis cliques da caixa grande, levante a parte superior da caixa e retire-a da parte inferior.

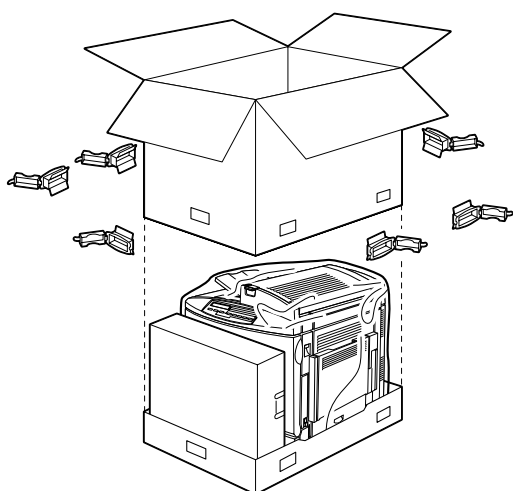

5. Retire cuidadosamente a caixa restante da parte lateral e coloque-a numa superfície estável.

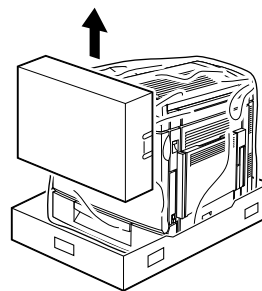

6. Levante e retire a impressora da caixa.



Importante:

- ❑ A impressora pesa cerca de 39,5 kg; para pegar nela, são necessárias, pelo menos, duas pessoas.
- ❑ Pegue na impressora pelas partes indicadas.

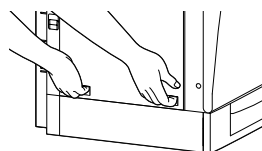

Lado esquerdo

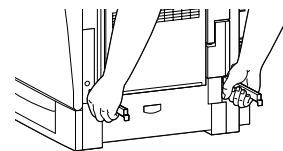

Lado direito

7. Abra todas as caixas e certifique-se de que tem todos estes elementos.

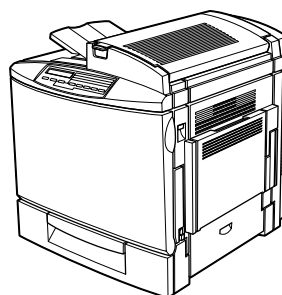

Impressora

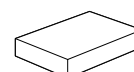

Caixa da documentação

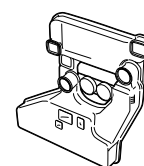

Caixa de Toner Residual

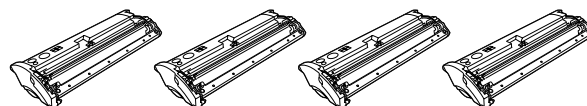

Unidades de revelação (Amarelo, Magenta, Azul e Preto)

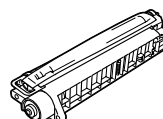

Unidade fotocondutora

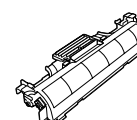

Rolo de óleo do fusor

Nota:

- ❑ Se o cabo de corrente estiver incluído, deverá encontrar-se na caixa grande com a impressora ou na caixa da documentação, consoante o país.
 - ❑ A ficha do cabo de corrente varia consoante o país; certifique-se de que possui a ficha adequada.
 - ❑ Em alguns países, é fornecido um fio de terra com a impressora.
8. Antes de começar a utilizar a impressora, é necessário retirar todos os materiais de protecção indicados nas figuras seguintes.

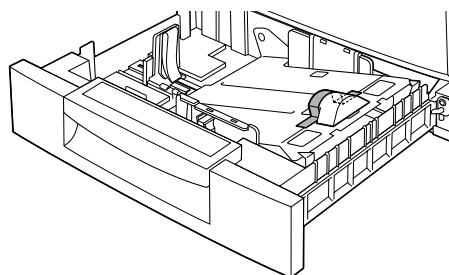
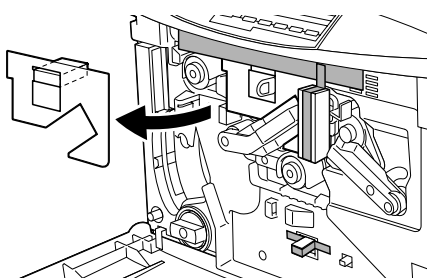
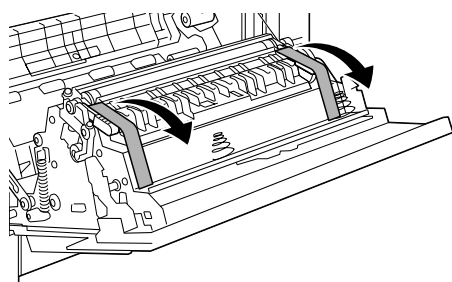
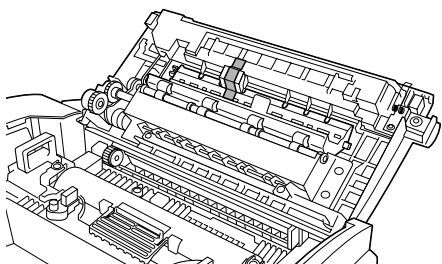

Importante:

Não se esqueça de retirar todas as fitas adesivas das várias partes da impressora.

2 Escolher um local para a impressora

Coloque a impressora num local que permita a sua fácil utilização e manutenção, conforme se indica em seguida.

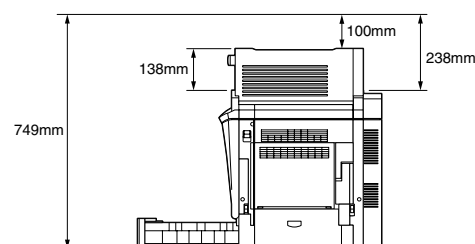
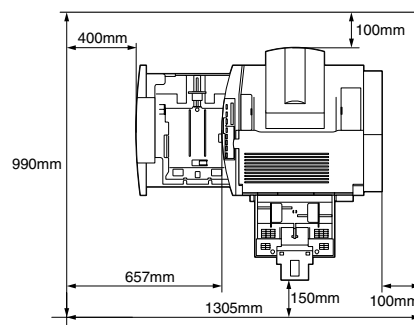

Para instalar uma das seguintes opções, precisará do seguinte espaço adicional:

Alimentador para 500 folhas: mais 114 mm na parte inferior da impressora.

Unidade Dúplex: mais 33 mm à direita da impressora.

Para além do espaço, tenha sempre em conta as seguintes recomendações quando escolher um local para colocar a impressora:

- ❑ Coloque a impressora num local onde possa desligar facilmente o cabo de corrente.
- ❑ Mantenha o computador e a impressora afastados de potenciais fontes de interferência electromagnética, tais como, colunas de som ou bases de telefones sem fio.
- ❑ Evite utilizar tomadas eléctricas controladas por interruptores de parede ou temporizadores automáticos. Um corte acidental de corrente pode apagar dados importantes guardados na memória do computador ou da impressora.



Importante:

- ❑ *Deixe espaço suficiente à volta da impressora para permitir a sua ventilação.*
- ❑ *Evite locais sujeitos a luz solar directa, temperaturas elevadas, humidade ou pó.*
- ❑ *Evite utilizar tomadas às quais outros equipamentos estejam ligados.*
- ❑ *Utilize uma tomada de terra adequada à ficha do cabo de corrente da impressora. Não utilize um adaptador.*
- ❑ *Utilize apenas uma tomada que respeite os requisitos energéticos desta impressora.*

