

# SERVICE MANUAL



EPSON EPL-N1600 Option  
**Duplex Unit**



**EPSON®**

## Notice

- All rights reserved. No part of this manual may be reproduced, stored in a retrieval system, or transmitted in any form or by any means electronic, mechanical, photocopying, or otherwise, without the prior written permission of SEIKO EPSON CORPORATION.
- All effort have been made to ensure the accuracy of the contents of this manual. However, should any errors be detected, SEIKO EPSON would greatly appreciate being informed of them.
- The contents of this manual are subject to change without notice.
- All effort have been made to ensure the accuracy of the contents of this manual. However, should any errors be detected, SEIKO EPSON would greatly appreciate being informed of them.
- The above notwithstanding SEIKO EPSON CORPORATION can assume no responsibility for any errors in this manual or the consequences thereof.

EPSON is a registered trademark of SEIKO EPSON CORPORATION.

*General Notice: Other product names used herein are for identification purpose only and may be trademarks or registered trademarks of their respective owners. EPSON disclaims any and all rights in those marks.*

# PRECAUTIONS

Precautionary notations throughout the text are categorized relative to 1) Personal injury and 2) damage to equipment.

**DANGER** Signals a precaution which, if ignored, could result in serious or fatal personal injury. Great caution should be exercised in performing procedures preceded by DANGER Headings.

**WARNING** Signals a precaution which, if ignored, could result in damage to equipment.

The precautionary measures itemized below should always be observed when performing repair/maintenance procedures.

## **DANGER**

1. ALWAYS DISCONNECT THE PRODUCT FROM THE POWER SOURCE AND PERIPHERAL DEVICES PERFORMING ANY MAINTENANCE OR REPAIR PROCEDURES.
2. NO WORK SHOULD BE PERFORMED ON THE UNIT BY PERSONS UNFAMILIAR WITH BASIC SAFETY MEASURES AS DICTATED FOR ALL ELECTRONICS TECHNICIANS IN THEIR LINE OF WORK.
3. WHEN PERFORMING TESTING AS DICTATED WITHIN THIS MANUAL, DO NOT CONNECT THE UNIT TO A POWER SOURCE UNTIL INSTRUCTED TO DO SO. WHEN THE POWER SUPPLY CABLE MUST BE CONNECTED, USE EXTREME CAUTION IN WORKING ON POWER SUPPLY AND OTHER ELECTRONIC COMPONENTS.

## **WARNING**

1. REPAIRS ON EPSON PRODUCT SHOULD BE PERFORMED ONLY BY AN EPSON CERTIFIED REPAIR TECHNICIAN.
  2. MAKE CERTAIN THAT THE SOURCE VOLTAGES IS THE SAME AS THE RATED VOLTAGE, LISTED ON THE SERIAL NUMBER/ RATING PLATE. IF THE EPSON PRODUCT HAS A PRIMARY AC RATING DIFFERENT FROM AVAILABLE POWER SOURCE, DO NOT CONNECT IT TO THE POWER SOURCE.
  3. ALWAYS VERIFY THAT THE EPSON PRODUCT HAS BEEN DISCONNECTED FROM THE POWER SOURCE BEFORE REMOVING OR REPLACING PRINTED CIRCUIT BOARDS AND/OR INDIVIDUAL CHIPS.
  4. IN ORDER TO PROTECT SENSITIVE MICROPROCESSORS AND CIRCUITRY, USE STATIC DISCHARGE EQUIPMENT, SUCH AS ANTI-STATIC WRIST STRAPS, WHEN ACCESSING INTERNAL COMPONENTS.
  5. REPLACE MALFUNCTIONING COMPONENTS ONLY WITH THOSE COMPONENTS BY THE MANUFACTURE; INTRODUCTION OF SECOND-SOURCE ICs OR OTHER NONAPPROVED COMPONENTS MAY DAMAGE THE PRODUCT AND VOID ANY APPLICABLE
1. EPSON WARRANTY.

# About This Manual

This manual describes basic functions, theory of electrical and mechanical operations, maintenance and repair procedures of the Duplex Unit for the EPL-N1600. The instructions and procedures included herein are intended for the experienced repair technicians, and attention should be given to the precautions on the preceding page.

## Contents

This manual consists of six chapters and Appendix.

### **CHAPTER 1. PRODUCT DESCRIPTIONS**

Provides a general overview and specifications of the product.

### **CHAPTER 2. OPERATING PRINCIPLES**

Describes the theory of electrical and mechanical operations of the product.

### **CHAPTER 3. TROUBLESHOOTING**

Provides the step-by-step procedures for troubleshooting.

### **CHAPTER 4. DISASSEMBLY AND ASSEMBLY**

Describes the step-by-step procedures for disassembling and assembling the product.

### **CHAPTER 5. ADJUSTMENTS**

Provides Epson-approved methods for adjustment.

### **CHAPTER 6. MAINTENANCE**

Provides preventive maintenance procedures and the lists of Epson-approved lubricants and adhesives required for servicing the product.

**APPENDIX** Provides the following additional information for reference:

- Connector pin assignments
- Electric circuit boards components layout
- Exploded diagram
- Electrical circuit boards schematics

## Symbols Used in This Manual

Various symbols are used throughout this manual either to provide additional information on a specific topic or to warn of possible danger present during a procedure or an action. Be aware of all symbols when they are used, and always read WARNING, CAUTION or NOTE messages.



Indicates an operating or maintenance procedure, practice or condition that, if not strictly observed, could result in injury or loss of life.



Indicates an operating or maintenance procedure, practice, or condition that, if not strictly observed, could result in damage to, or destruction of, equipment.



May indicate an operating or maintenance procedure, practice or condition that is necessary to accomplish a task efficiently. It may also provide additional information that is related to a specific subject, or comment on the results achieved through a previous action.



# Table of Contents

## *Product Descriptions*

---

OVERVIEW .....	9
Basic specification .....	9
Paper specification.....	9
Reliability/Durability/serviceability .....	9
dimension and weight .....	9

## *Operating Principles*

---

OVERVIEW .....	11
Paper Transportation.....	11
paper transportation control .....	13
Scanning direction in duplex printing .....	13
Drive Power Transmission .....	14
Duplex unit drive power transmission (1).....	15
Duplex unit drive power transmission (2).....	15
Function of Duplex Unit Major Components.....	16
Vertical Unit .....	16
Horizontal Unit .....	18

## *Troubleshooting*

---

### **DISASSEMBLY AND ASSEMBLY**

---

OVERVIEW .....	23
Precautions .....	23
Tools.....	23
DISASSEMBLY AND ASSEMBLY .....	24
Duplex Unit Removal.....	25
Duplex Assembly Unit Vertical .....	26

Chute Cover .....	27
Fan Assembly Duplex .....	28
Sensor Assembly (Vertical).....	29
Motor Duplex.....	30
Solenoid .....	31
Shaft Latch & Lever.....	32
Rolls Pinch & Roll Assembly Exit .....	33
Chute Lower & Roll Assembly.....	34
Photo Interrupters (Rear I/L & Chute Cover I/L).....	35
Photo Interrupter (PL11.1.9: Rear Interlock).....	35
Photo Interrupter (PL11.2.15: Chute Cover Interlock) .....	35
Chute Upper.....	36
Sensor Assembly (Horizontal).....	37
Roll Assembly #1 & Pinch Roll.....	38
Plate Base .....	39
Roll Assemblies #2 & #3 .....	40
PWB Assembly Duplex .....	41
Bracket & Gear Assembly .....	42

## *Adjustment*

---

## *Maintenance*

---

## *Appendix*

---

Connector Location .....	49
Exploded Diagram.....	50
Duplex Unit (Optional).....	50
Duplex Unit Vertical I .....	52
Duplex Unit Vertical II .....	54
Duplex Unit Vertical III .....	56

Duplex Unit Horizontal I ..... 58  
Duplex Unit Horizontal II ..... 60  
Duplex Unit Chute ..... 62

**CHAPTER**

**1**

**PRODUCT DESCRIPTIONS**

## 1.1 OVERVIEW

This section describes the specification of the 500 Sheets feeder.

### BASIC SPECIFICATION

Paper Handling:	Tray reverse
Drive Source:	Driven by the base printer
Speed:	A4 = 7.8PPM / Letter = 8.0PPM
Capacity:	1 sheet (in reverse tray)
Paper Feed Origin:	Left edge of sheet

### PAPER SPECIFICATION

Paper Type:	<Standard Paper> Xerox 4024DP 20 lb. (75g/m <sup>2</sup> ) paper <Normal Paper> 60 - 105 g/m <sup>2</sup> (16 - 28 lbs.) - PPC Paper - Bond paper - Recycled paper
Paper Size:	A4 (210 x 297mm) Letter (8.5 x 11 inch) G-Legal (8.5 x 13 inch) Legal (8.5 x 14 inch)

### RELIABILITY/DURABILITY/SERVICEABILITY

MPBF:	25,000 sheets or more
MTBF:	3,000 hours or more
Life:	300,000 sheets or 5 years (whichever comes first)
Paper Feed Reliability *1:	<Jam rate> 1/2000 sheets or less <Misfeed> 1/2000 sheets or less <Multiple sheet feed> 1/500 sheets or less <Folded coners> 1C or more at 1/1000 sheets or less (1C or less is not included)

#### NOTE:

\*1:With recommended paper and normal conditions

MTTR:	30 minutes or less
-------	--------------------

### DIMENSION AND WEIGHT

Dimension:	396 x 517 x 254 mm (W x D x H)
Weight:	6.5 Kg

**CHAPTER**

**2**

**OPERATING PRINCIPLES**

## 2.1 OVERVIEW

This section describes the operating principles of the Duplex Unit.

### 2.1.1 Paper Transportation

Paper is transported through the printer Base Engine and the Duplex Unit along the paper path shown in the Figure below when the Duplex Mode is selected or the optional Face UP Catch Tray is installed and selected. In the Duplex Mode, a sheet of paper printed on one side is guided into the Duplex Unit to re-feed, turned over in the Duplex Unit, reversed, and fed again into the Base Engine. When the optional Offset Catch Tray is selected, a sheet printed on one side in the Simplex Mode or a sheet printed on both sides is delivered into the Face Up Catch Tray through the Duplex Unit.

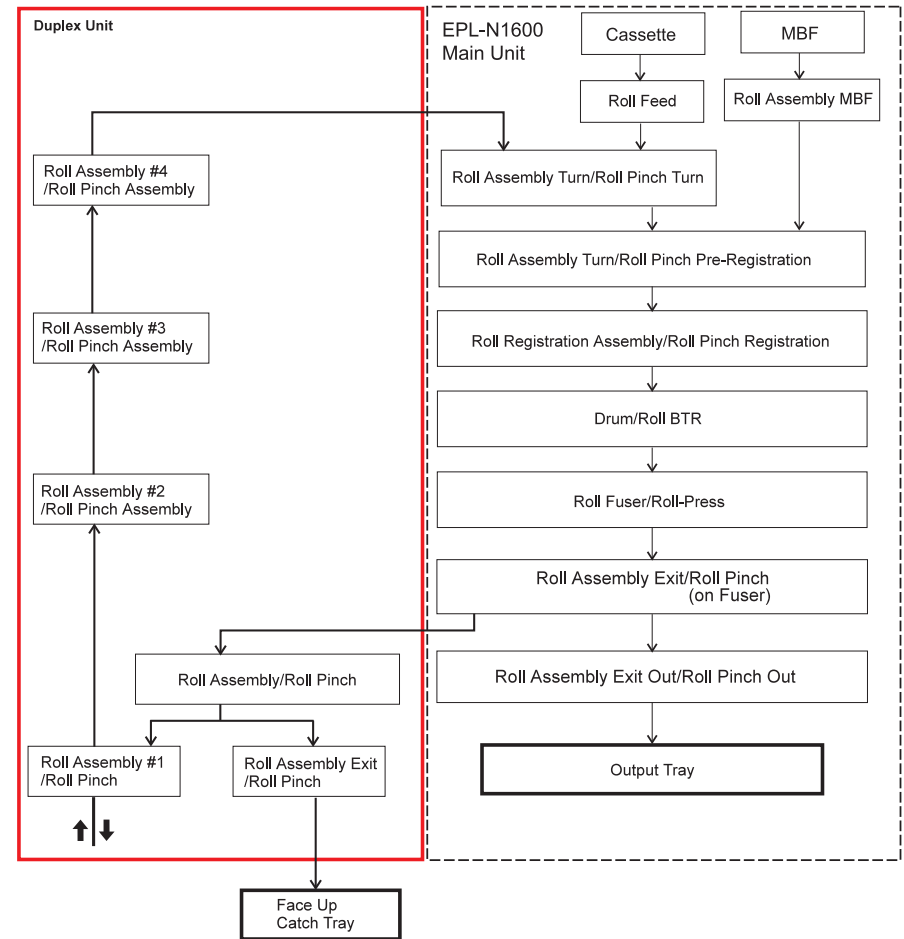

Figure 2-1. Paper Transport Path

The Figure below is a cut-section side view of the EPL-N1600 with the optional Duplex Unit attached that shows the paper path and the major components directly related to the paper transportation.

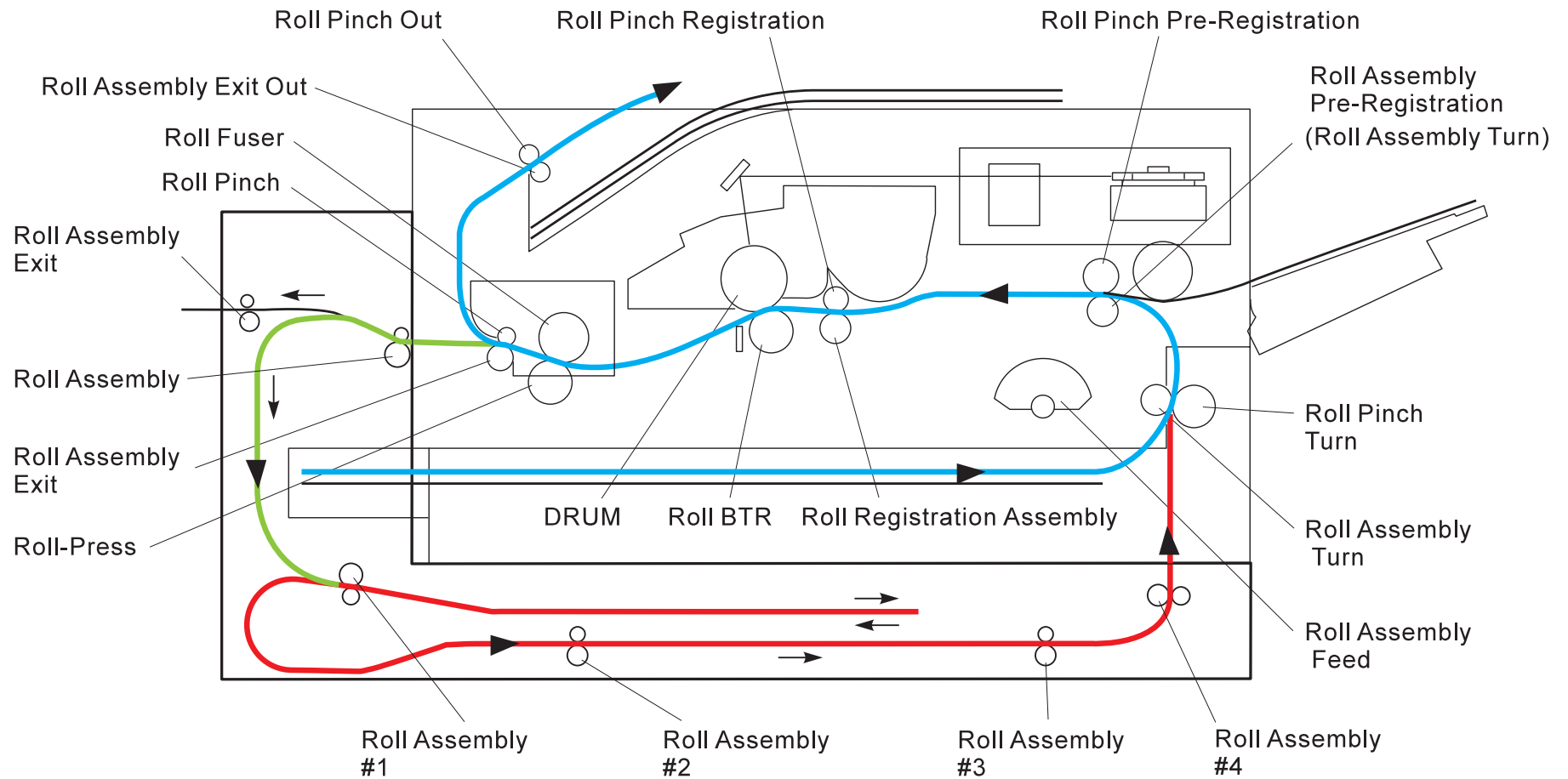
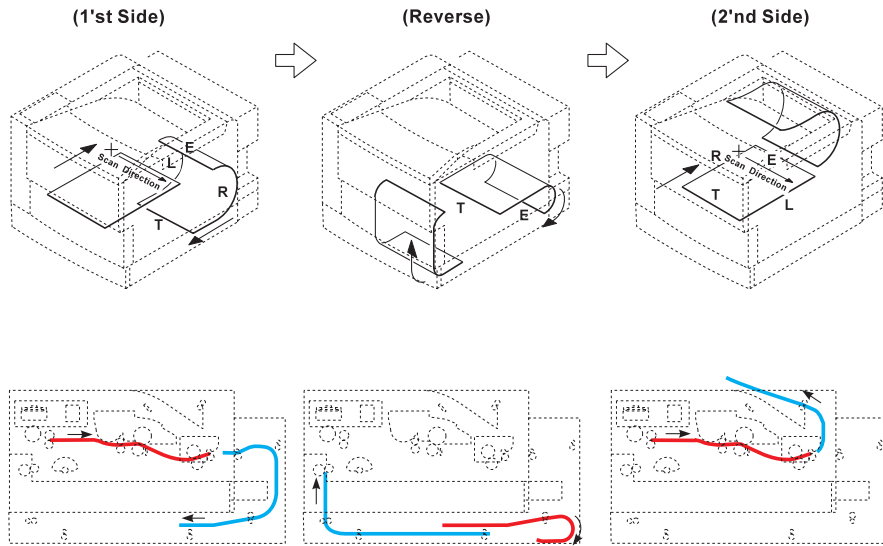

Figure 2-2. Duplex Printing Paper Path

**PAPER TRANSPORTATION CONTROL**

The figure below shows the paper movements in duplex printing mode.



**Figure 2-3. Paper Movement Control**

**SCANNING DIRECTION IN DUPLEX PRINTING**

The figure below shows the relationship between the main and sub scanning direction and a side of the page printed in duplex printing. The controller sends the image data to the engine according to the printing order of pages, lines (raster lines) on each page and pixels on each line.

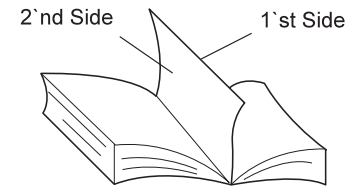
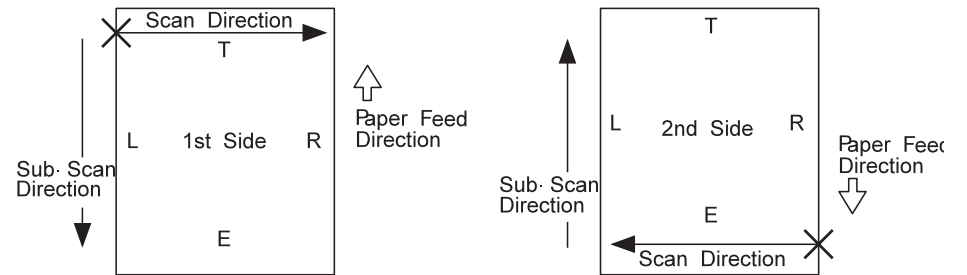

**Figure 2-4. Scanning Direction**

### 2.1.2 Drive Power Transmission

The Duplex Unit is operated by the drive power generated by the Main Motor and the Paper Handling Motor of the Base Engine and by the drive power generated by the Motor Duplex within the Duplex Unit. The figure in right shows the relations of each components.

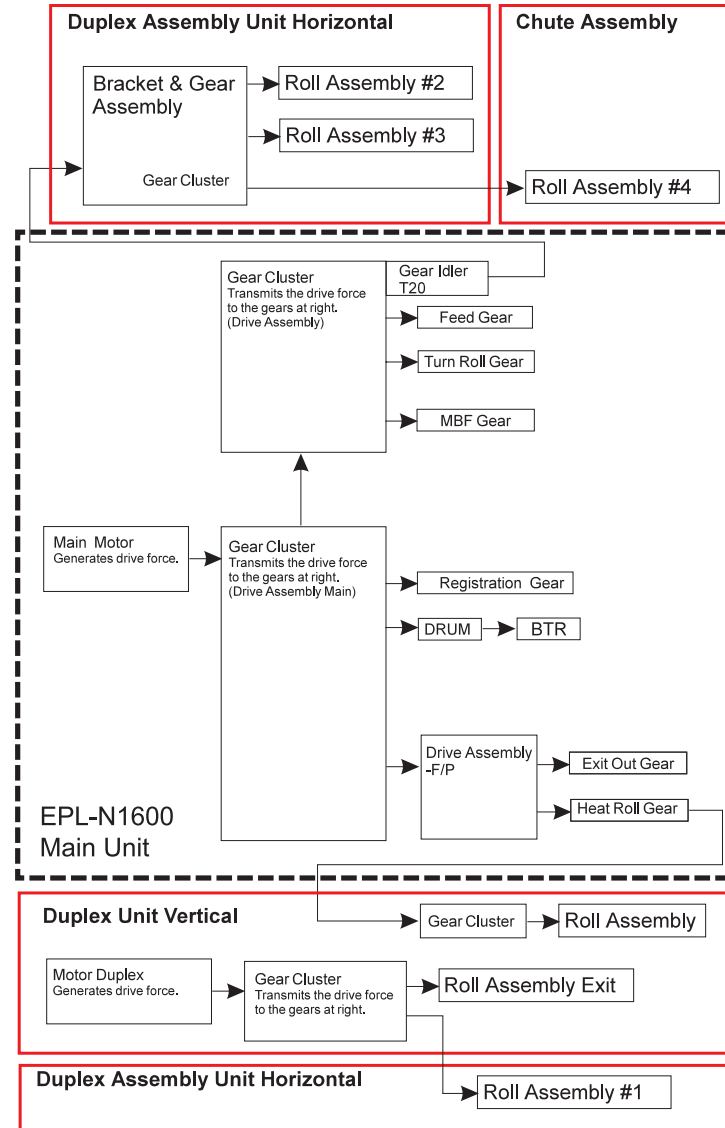
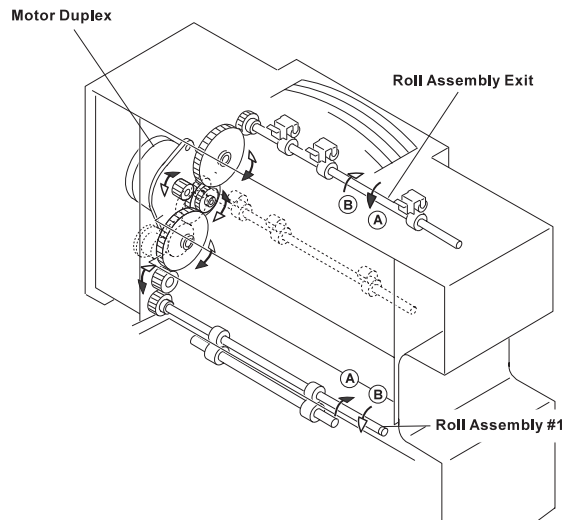
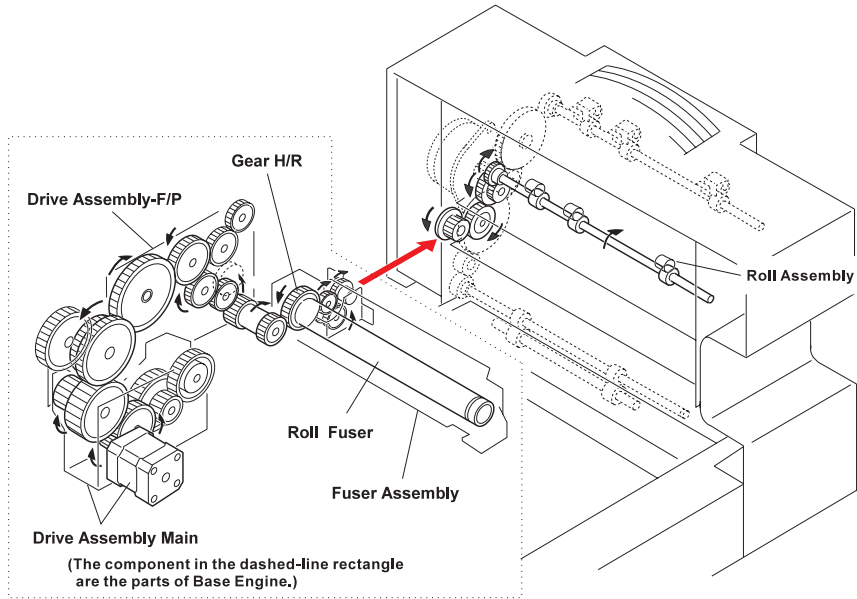
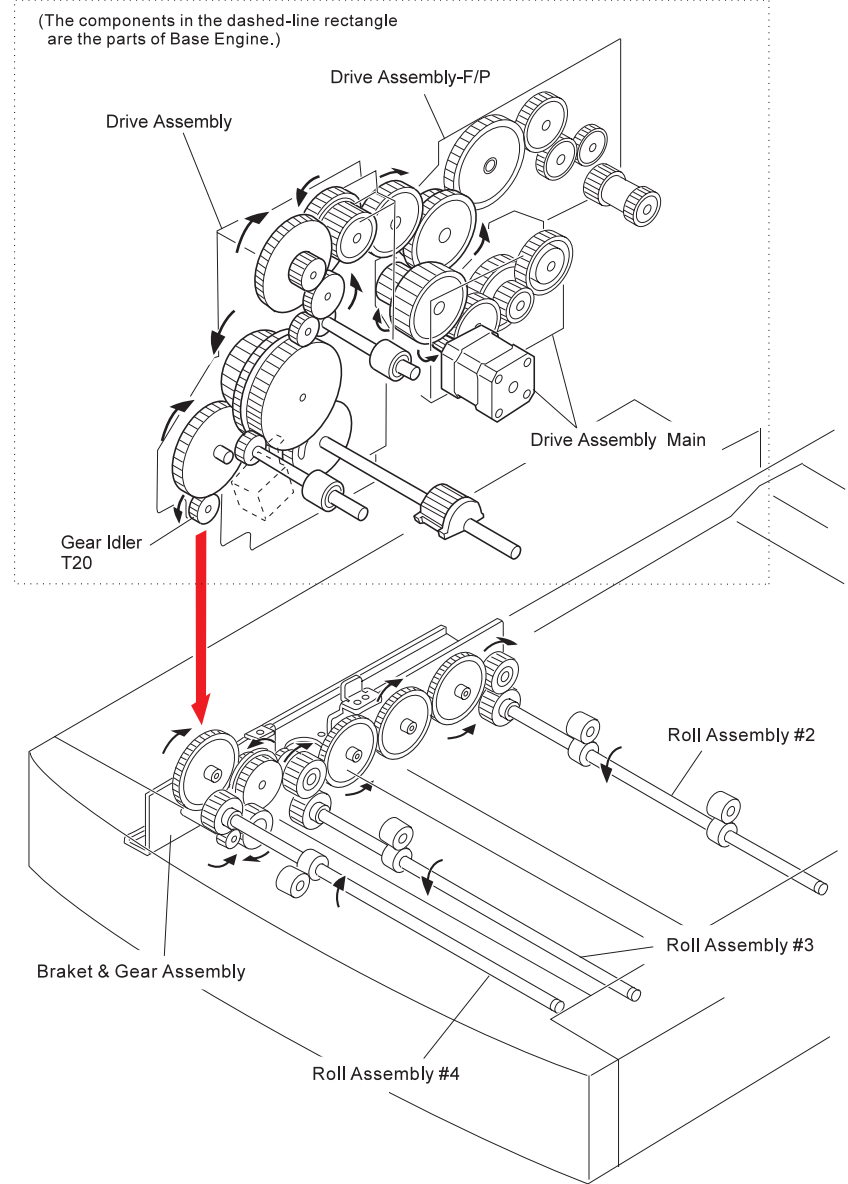

Figure 2-5. Drive Power Transmission

DUPLEX UNIT DRIVE POWER TRANSMISSION (1)



DUPLEX UNIT DRIVE POWER TRANSMISSION (2)



### 2.1.3 Function of Duplex Unit Major Components

#### VERTICAL UNIT

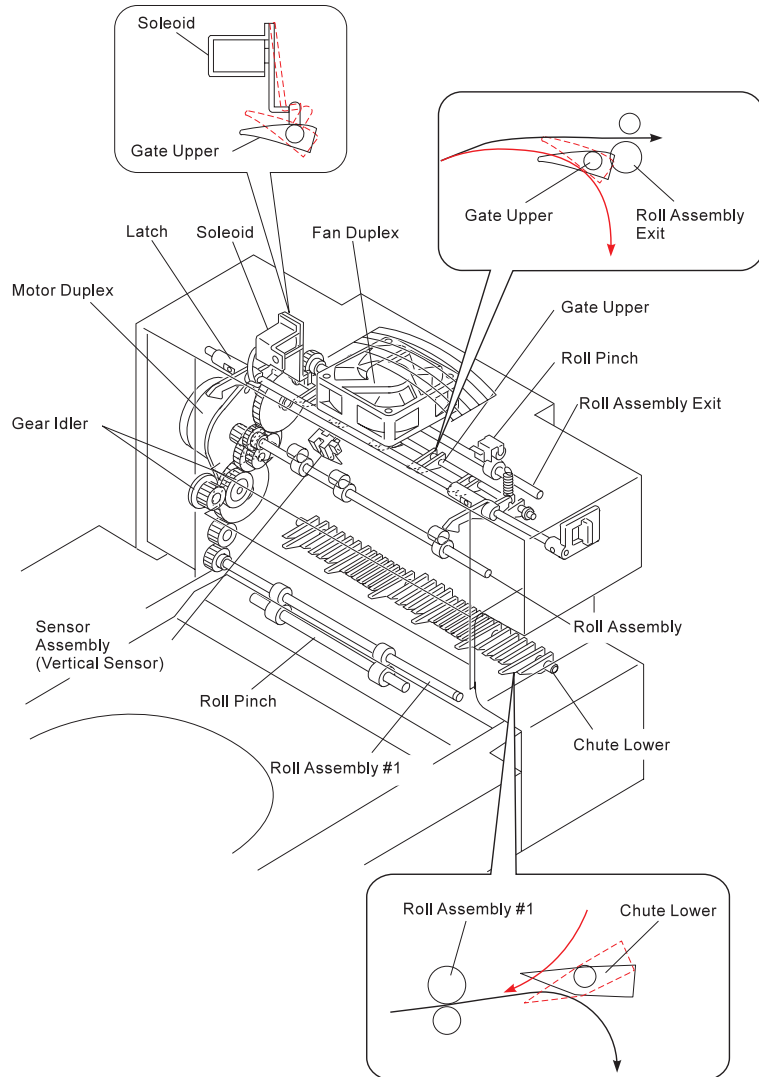

Figure 2-6. Duplex Unit - Vertical unit Components

Motor Duplex:

Generates the drive power for the Duplex Unit.

Gear Cluster:

Transmits the drive power from the Motor Duplex to the Roll Assembly Exit and to Roll Assembly #1 (part of the Horizontal Unit). When the Vertical Unit is in place, the Idler Gear in the Gear Cluster engages the gear on the end of the Roll Assembly #1 shaft, and transmits the drive power to Roll Assembly #1. When the Vertical Unit is tilted back, the Idler Gear disengage from the gear on the Roll Assembly #1 shaft.

Roll Assembly:

Works with Rolls Pinch to drive paper from the Fuser Exit Roll Assembly into the Vertical Unit. The drive power is transmitted from the Base Engine to the Roll Assembly, through the Duplex Gear Assembly of the Base Engine and the gears in the Duplex Unit.

Roll Assembly Exit:

Works with Rolls Pinch to drive paper out into the Face Up Catch Tray. The drive power for the Roll Assembly Exit is transmitted from the Motor Duplex through the Gear Cluster.

Gate Upper:

A moving baffle that switches the paper path to either Roll Assembly #1 or to the Roll Assembly Exit.

Solenoid:

Toggles the Gate Upper.

- Sensor Assembly:** Sensor in the Vertical Unit which is located near the inlet and detects paper which enters the Duplex Unit. This sensor is also called the Vertical Sensor.
- Chute Lower:** Pushed down by the paper coming from the Gate Upper, allowing the paper to proceed on to Roll Assembly #1. Without the weight of the paper pushing it down, the Gate returns to its raised position. Then the sheet of paper, driven in the reverse direction by Roll Assembly #1, is guided by the bottom side of the Gate Lower to Roll Assembly #2.
- Fan Duplex:** Expels the air inside the Duplex Unit (and the printer through the rear exit of the printer) and introduces fresh air into the Duplex Unit and the printer) to prevent an excessive rise of the inside temperature.
- Latch:** Secures the Vertical Unit to the rear of the Base Engine.

---

**HORIZONTAL UNIT**

---

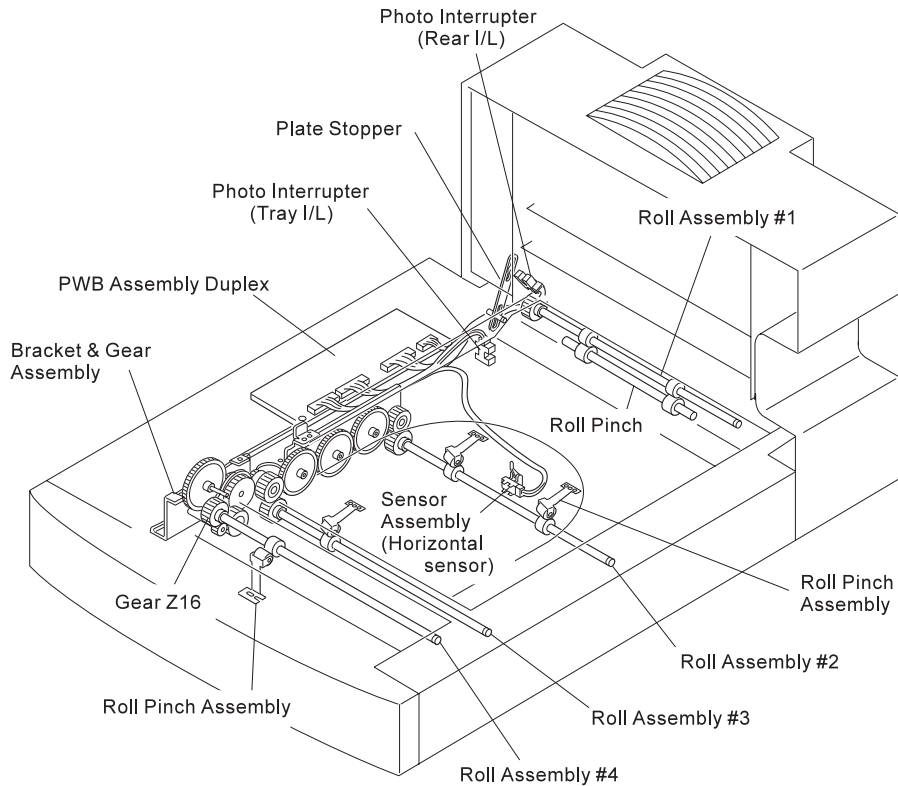

**Figure 2-7. Duplex Unit - Horizontal Unit Components**

**Bracket & Gear Assembly:** Receives the drive power from the Base Engine, and transmits it to Roll Assemblies #2, #3, and #4 of the Horizontal Unit.

**Roll Assembly #:** Receives the drive power from the Motor Duplex and Gear Cluster which are part of the Vertical Unit. Roll Assembly #1 rotates forward when receiving a sheet of paper with the first side printed. Roll Assembly #1 then rotates in reverse to drive the sheet to Roll Assembly #2 in preparation for printing the second side of the sheet.

**Roll Assemblies#2/3/4:** Drive the paper into and out of the Duplex Unit.

**PWBA Assembly Duplex:** Controls the Duplex Unit operation. The 4-bit MPU on the PWBA Duplex receives commands from the PWBA MMCU, receives signals from the Sensors within the Duplex Unit, actuates the Solenoid Duplex, and the Motor Duplex, and returns the status of the Duplex Unit.

**Horizontal Sensor:** Detects when a sheet of paper reaches Roll Assembly #2.

**Duplex Unit ChuteCover Interlock:** Photo interrupter (PL11.24) that monitors whether or not the Duplex Unit Chute Cover is in place.

**Vertical Unit Interlock:** Photo interrupter (PL11.24) that monitors whether or not the Vertical Unit is in position against the rear of the Base Engine.

Plate Stopper: Support and limiting arm for the Vertical Unit

Solenoid: Toggles the Gate Upper.

**CHAPTER**

**3**

**TROUBLESHOOTING**

*This chapter is not applicable to the Duplex Unit.*

**CHAPTER**

**4**

**DISASSEMBLY AND ASSEMBLY**

## 4.1 OVERVIEW

This chapter explains how to disassemble the Duplex Unit and its various mechanisms. Except where otherwise indicated, the reassembly procedure is the reverse of the disassembly procedure.

### 4.1.1 Precautions

This section describes the precautions you must take to prevent accidents during disassembly and reassembly work. Be sure to carry out all work in accordance with the precautions and general instructions provided in this manual.



- **Be careful to avoid injury from frame edges and other sharp or protruding areas of the printer.**
- **Avoid touching IC elements with bare hands, so as to prevent possible damage from electrostatic discharge. If you need to touch these areas, wear appropriate electrostatic protection gear (electrostatic wrist band, etc.).**
- **To ensure work efficiency and safety, use only the tools specified in this manual.**
- **The unit uses screws of many different types. Be sure to note the correct location for each screw before removing it. Inserting screws into the wrong places may strip or damage the screw holes.**

### 4.1.2 Tools

The following table lists the tools you need to disassemble and reassemble the printer.

**Table 4-1. Required Tools**

Tool	Market Availability	Code
Phillips screwdriver	Yes	B743800200
Tweezers	Yes	B641000100
Round nose pliers	Yes	B740400100

## 4.2 DISASSEMBLY AND ASSEMBLY

---

This section describes the procedures for disassembling the Duplex Unit. The assembly of the unit can be made by performing the disassembly step in reverse order unless otherwise specified, and the assembly procedure is therefore omitted in this manual.

### 4.2.1 Duplex Unit Removal

1. Switch OFF printer power and remove the AC power cord from the rear of the printer.
2. Disconnect all interface cables from the rear of the printer.
3. Remove the 500 Sheet Feeder, if one is installed.
4. Push the Vertical Unit release lever to the rear (1) and tilt the Vertical Unit away from the printer (2).
5. Press the Feeder Joint Clips together and remove the two rear feeder joints securing the Duplex Unit to the Printer.
6. Remove the 250 Sheet Cassette and the Chute Assembly (4).
7. Press the feeder joint clips together and remove the two front feeder joints securing the Duplex Unit to the printer (5).
8. Lift the base engine off of the Duplex Unit.

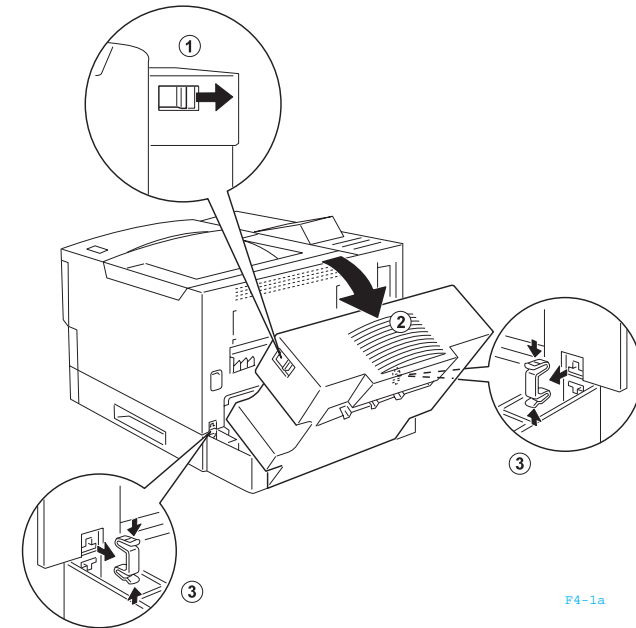

F4-1a

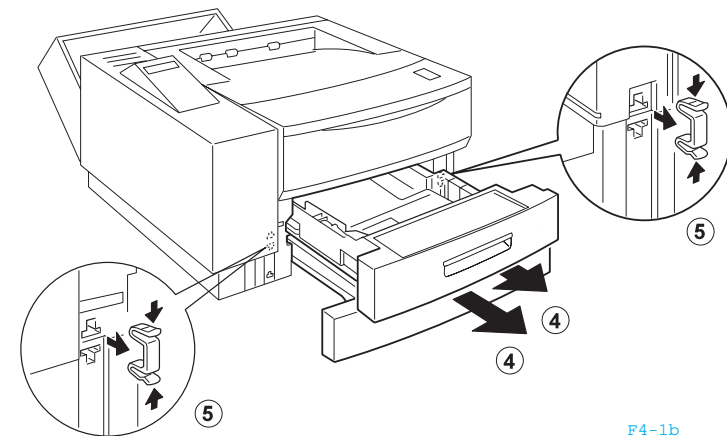

F4-1b

**Figure 4-1. Duplex Unit Removal**

## 4.2.2 Duplex Assembly Unit Vertical

1. Remove the Duplex Unit.
2. Remove the Chute Upper.
3. Slide the end of the Plate Stopper off of the post on the Frame L/H (1).
4. Tilt back the Vertical Unit (2).
5. Remove the wire clamp that holds the harness.
6. Remove the Bracket Sensor of the Rear Interlock Switch (PL11.1.9: Photo Interrupter) (4).
7. Disconnect J230 (5).
8. Remove the two screws that are securing the Plate Assembly Pivot and ground wire to the Frame L/H (6).
9. Pry off the Plate Assembly Pivot (7).
10. Slide the Duplex Assembly Unit Vertical to the left to free the right pivot from the Horizontal Unit, and remove the Vertical Unit.

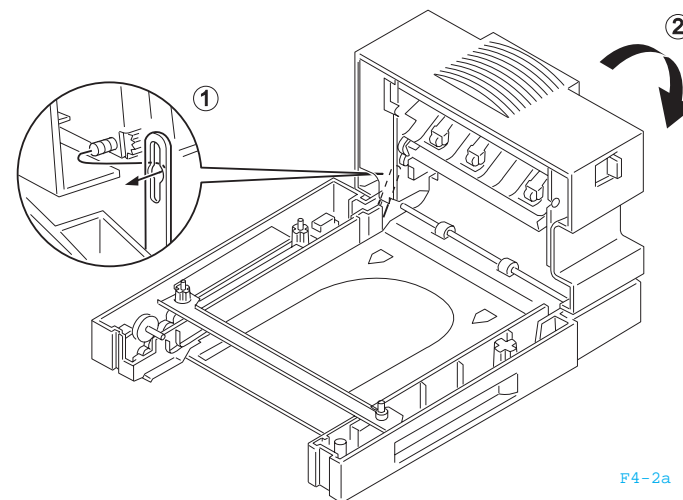

F4-2a

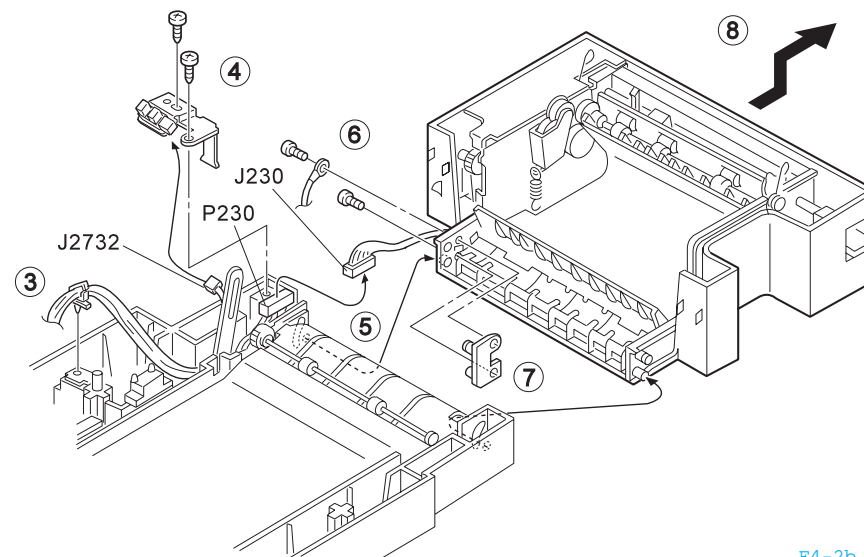

F4-2b

Figure 4-2. Duplex Assembly Unit Vertical Removal

### 4.2.3 Chute Cover

1. Remove the Duplex Unit.
2. Remove the Chute Upper.
3. Remove the Duplex Assembly Unit Vertical.
4. Remove the two screws that secure the Plate Cover to the Frame L/H, and remove the Plate Cover.
5. Remove the seven screws that are securing the Chute Cover to the Duplex Assembly Unit Vertical.
6. Lift the Duplex Assembly Unit Vertical out of the Chute Cover.

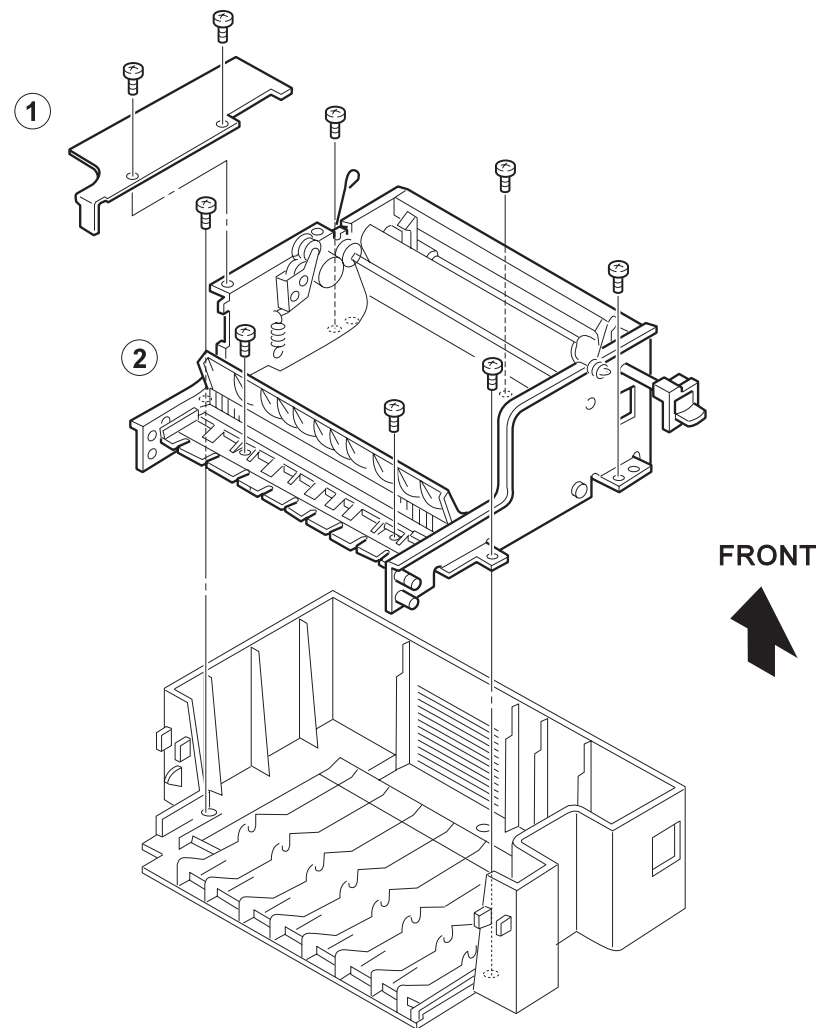

Figure 4-3. Chute Cover Removal

### 4.2.4 Fan Assembly Duplex

1. Remove the Duplex Unit.
2. Remove the Chute Upper.
3. Remove the Duplex Assembly Unit Vertical.
4. Remove the Chute Cover.
5. Disconnect P249/J2491 and route the Harness Vertical out of the Frame.
6. Remove the two screws that secure the Fan Assembly Duplex to the Bracket Fan.
7. Remove the Fan.

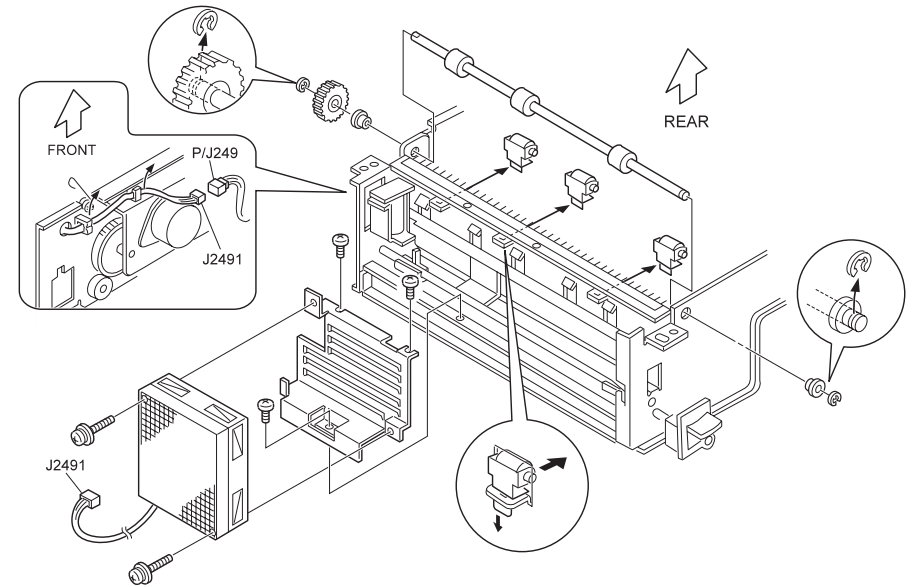

Figure 4-4. Fan Assembly Duplex Removal

F4-4

### 4.2.5 Sensor Assembly (Vertical)

1. Remove the Duplex Unit.
2. Remove the Chute Upper.
3. Remove the Duplex Assembly Unit Vertical.
4. Remove the Chute Cover.
5. Remove the Fan Assembly Duplex.
6. Disconnect J246 from the Sensor Assembly (Vertical).
7. Press in on the latching clips that are securing the Sensor to the Frame, and remove the Sensor.

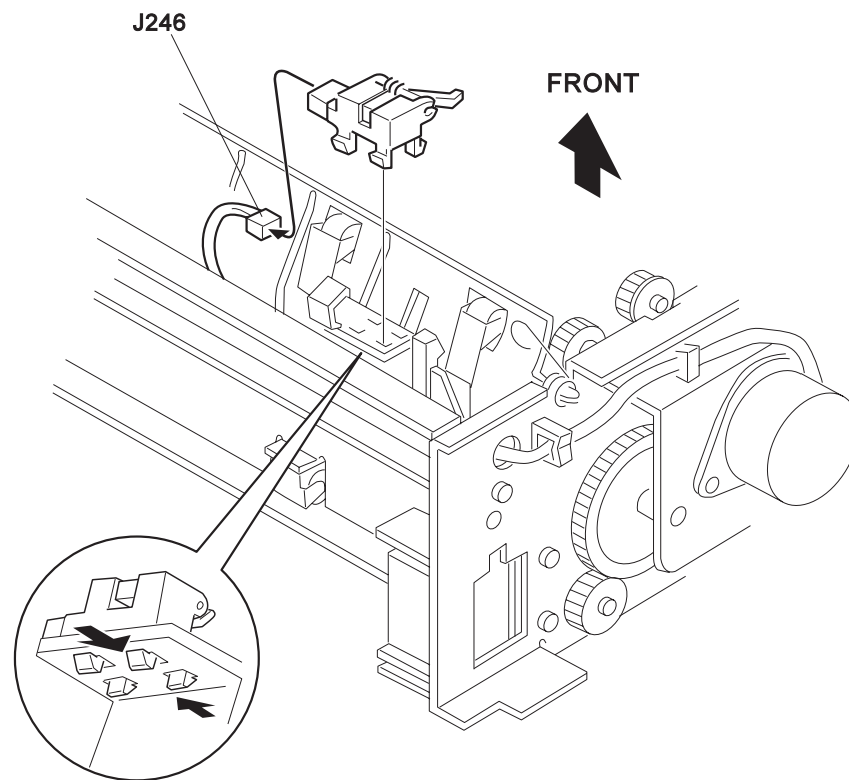

Figure 4-5. Sensor Assembly (Vertical) Removal

### 4.2.6 Motor Duplex

1. Remove the Duplex Unit.
2. Remove the Chute Upper.
3. Remove the Duplex Assembly Unit Vertical.
4. Remove the Chute Cover.
5. Disconnect J244 from the Motor Duplex.
6. Remove the two screws that are securing the Motor Duplex to the Bracket, and remove the Motor.

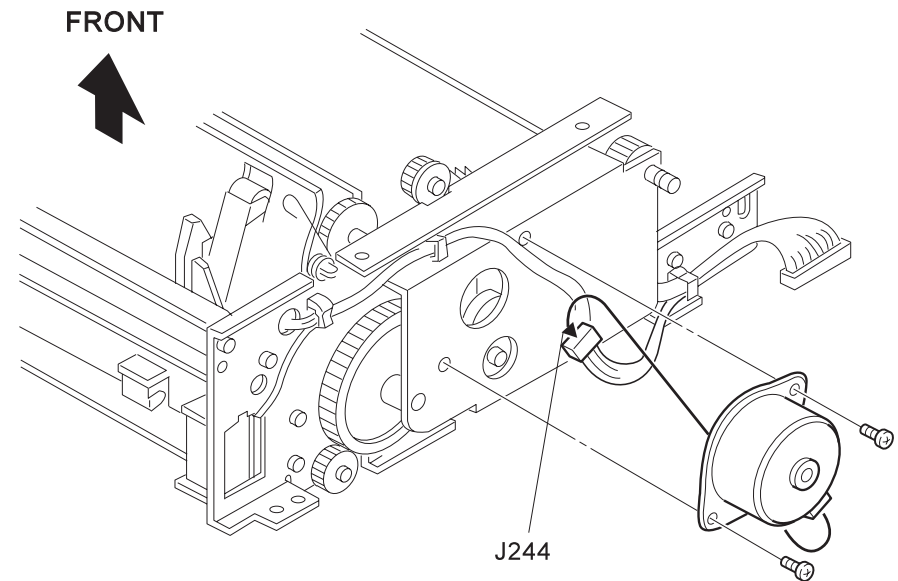

Figure 4-6. Motor Duplex Removal

### 4.2.7 Solenoid

1. Remove the Duplex Unit.
2. Remove the Chute Upper.
3. Remove the Duplex Assembly Unit Vertical.
4. Remove the Chute Cover.
5. Disconnect J2471 (Solenoid) from P247.
6. Free the harness of the Solenoid from the wire clamp.
7. Turn the Chute Cover upside down.
8. Remove the screw that is securing the Solenoid to the Frame L/H.
9. Remove the Solenoid.

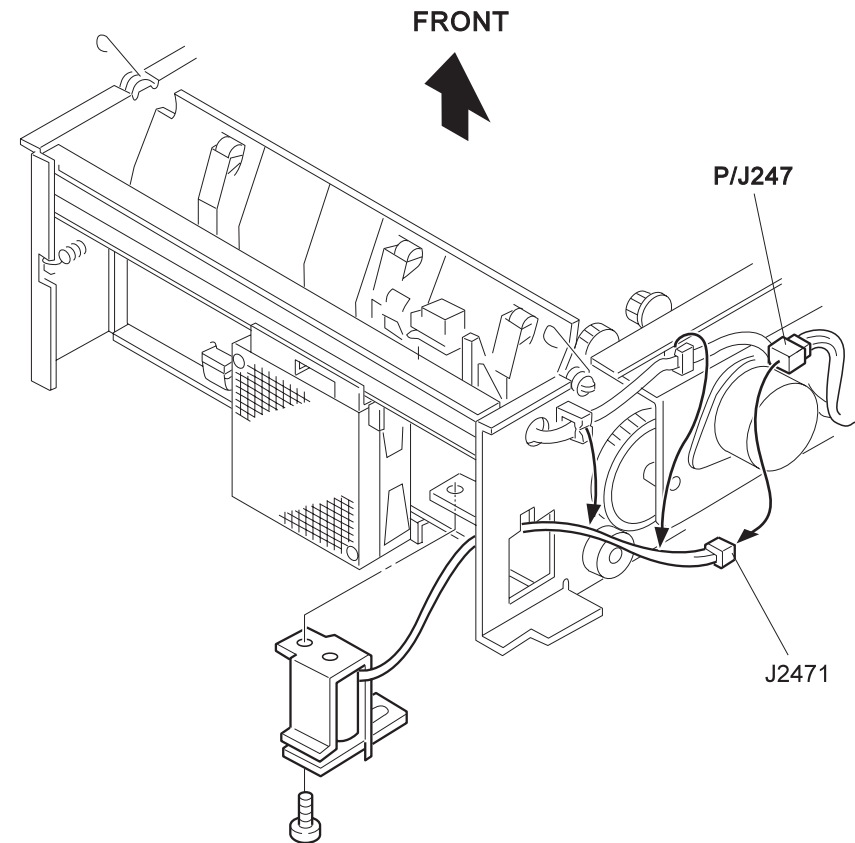

Figure 4-7. Solenoid Removal

### 4.2.8 Shaft Latch & Lever

1. Remove the Duplex Unit.
2. Remove the Chute Upper.
3. Remove the Duplex Assembly Unit Vertical.
4. Remove the Chute Cover.
5. Remove the screw that is securing the left Latch to the Shaft Latch, and remove the Latch.
6. Remove the Spring that is attached to the right Latch.
7. Remove the screw that is securing the right Latch to the Shaft Latch, and remove the Latch.
8. Slide the Shaft Latch, along with the attached Lever, to the right and out of the Frame.

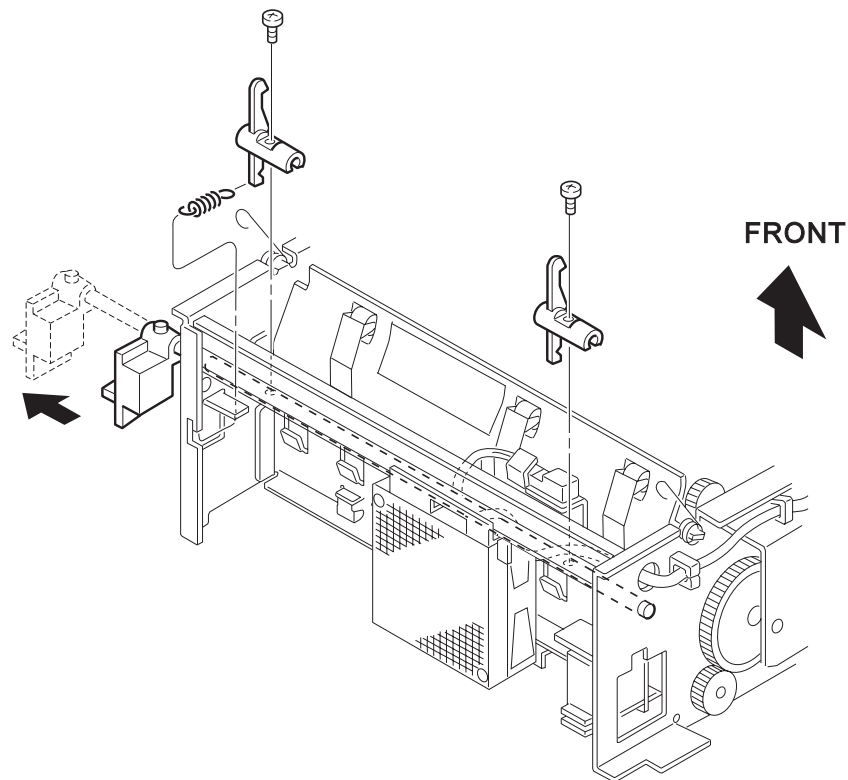
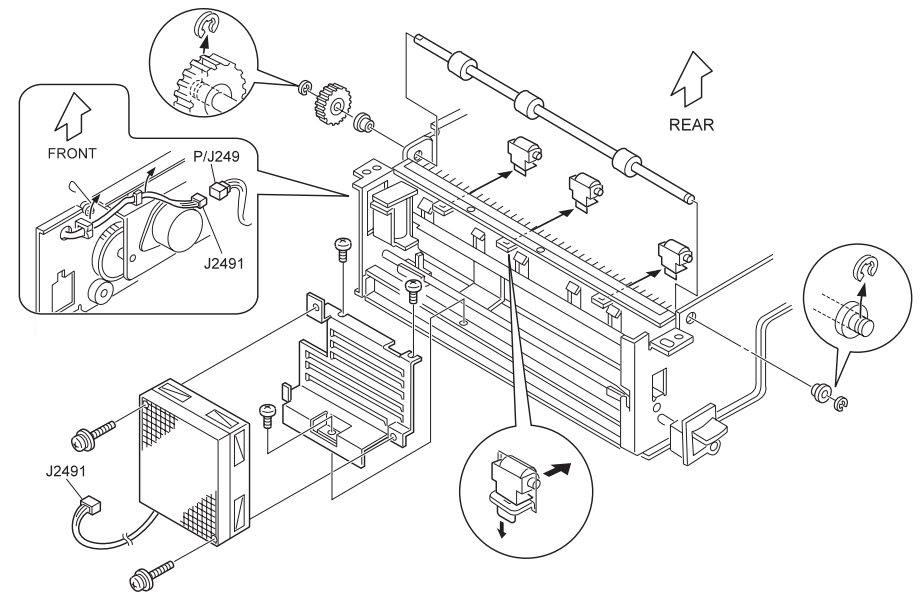

Figure 4-8. Shaft Latch/Lever Removal

### 4.2.9 Rolls Pinch & Roll Assembly Exit

1. Remove the Duplex Unit.
2. Remove the Chute Upper.
3. Remove the Duplex Assembly Unit Vertical.
4. Remove the Chute Cover.
5. Remove the Fan Assembly Duplex.
6. Remove the three screws that secure the Bracket Fan to the Chute Upper 2 and Plate Tie.
7. Remove the E-rings from both ends of the shaft of the Roll Assembly Exit.
8. Remove the Bearing from the right end of the shaft.
9. Remove the Gear and Bearing from the left end of the shaft.
10. Slide the shaft to the left until the right end is freed from the Frame.
11. Slide the shaft to the right and out of the Frame.
12. Press down each Roll Pinch clip and remove the three Pinch Rolls from the Chute.



**Figure 4-9. Rolls Pinch/Roll Assembly Exit Removal**

### 4.2.10 Chute Lower & Roll Assembly

1. Remove the Duplex Unit.
2. Remove the Chute Upper.
3. Remove the Duplex Assembly Unit Vertical.
4. Remove the Chute Cover.
5. Remove the two screws that are securing the Chute Invert-V/TRA to the Frame R/H and Bracket Pivot R/H.
6. Pull the Frame R/H away from the Chute Invert-V/TRA so you can free the Chute Lower right pivot from the Frame R/H.
7. Slide the Chute Lower to the right and free the Chute Lower left pivot from the Frame L/H and remove the Chute Lower from the Frame.
8. Remove the E-rings from both ends of the shaft of the Roll Assembly.
9. Remove the Bearing from the right end of the shaft:
10. Remove the Gear and Bearing from the left end of the shaft.
11. Lift the Roll Assembly off of the Chute Lower.

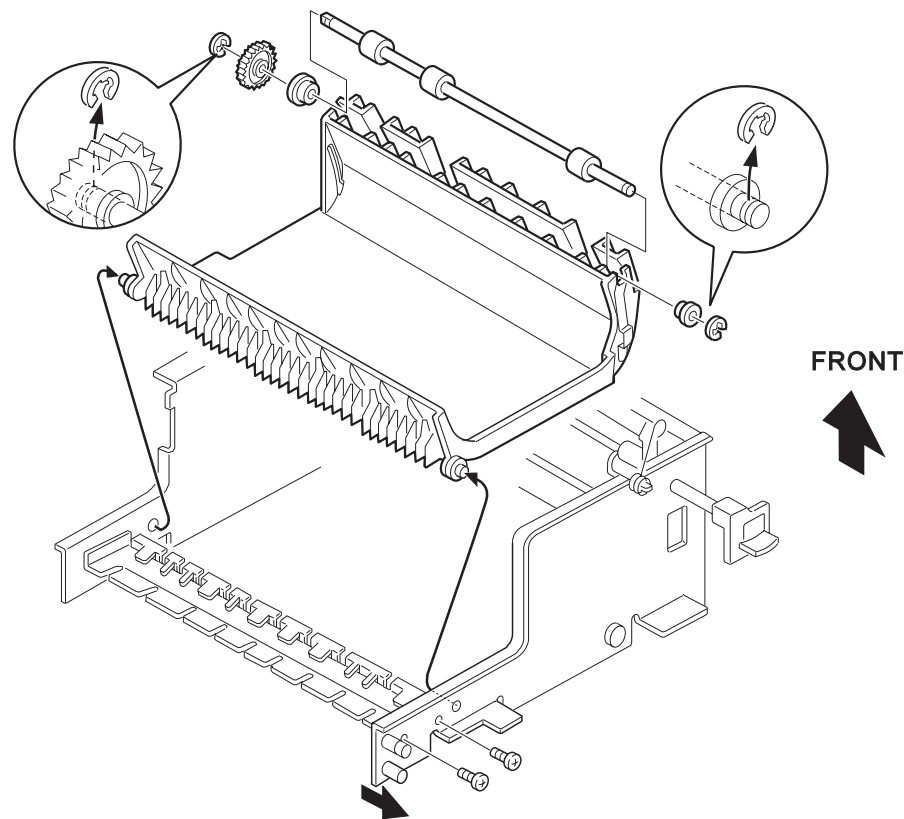

**Figure 4-10. Chute Lower/Roll Assembly Removal**

### 4.2.11 Photo Interrupters (Rear I/L & Chute Cover I/L)

1. Remove the Duplex Unit.
2. Slide the end of the Plate Stopper off of the post on the Frame L/H. See the illustration (1).
3. Tilt back the Duplex Assembly Unit Vertical.

---

#### PHOTO INTERRUPTER (PL11.1.9: REAR INTERLOCK)

---

4. Remove the two screws that is securing the Rear Interlock Bracket Sensor to the Frame.
5. Remove the Bracket, along with the attached Rear Interlock Switch.
6. Disconnect J2732 from the Rear Interlock Switch.
7. Press in on the locking clips and remove the Rear Interlock Switch from the Bracket.

---

#### PHOTO INTERRUPTER (PL11.2.15: CHUTE COVER INTERLOCK)

---

8. Remove the Chute Upper.
9. Slide the Chute Assembly out of Duplex Unit.
10. Press in on the locking clips and remove the Chute Cover Interlock Switch from the Support Duplex-L/H.
11. Disconnect J2733 from the Chute Cover Interlock Switch.

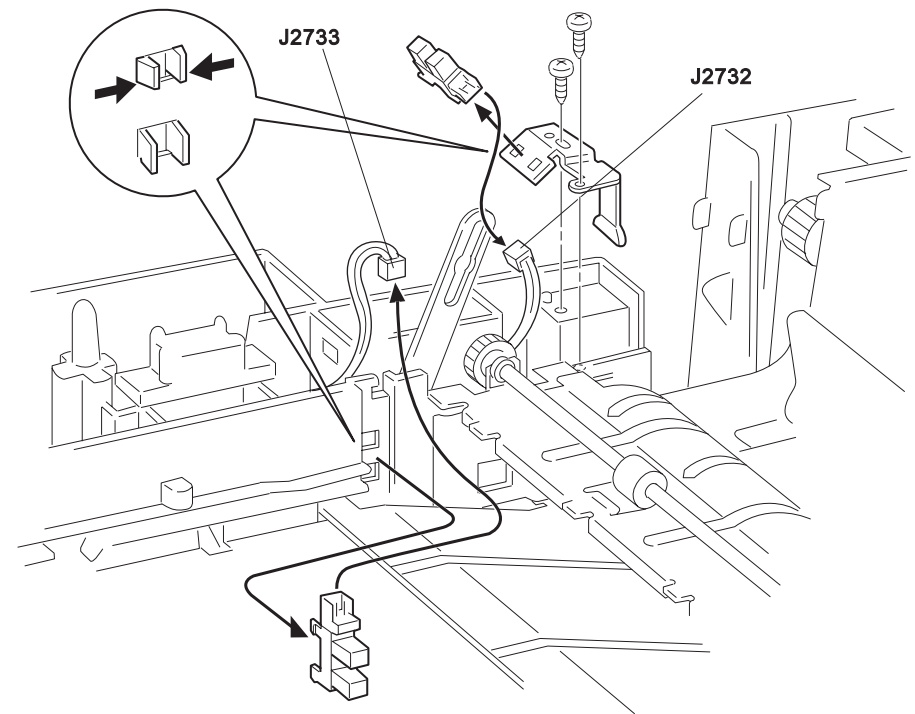

Figure 4-11. Photo Interrupter (Rear I/L, Chute Cover I/L) Removal

### 4.2.12 Chute Upper

1. Tilt back the Duplex Assembly Unit Vertical.
2. Remove the four screws that are securing the Chute Upper to the Horizontal Unit.
3. Remove the Chute Upper.

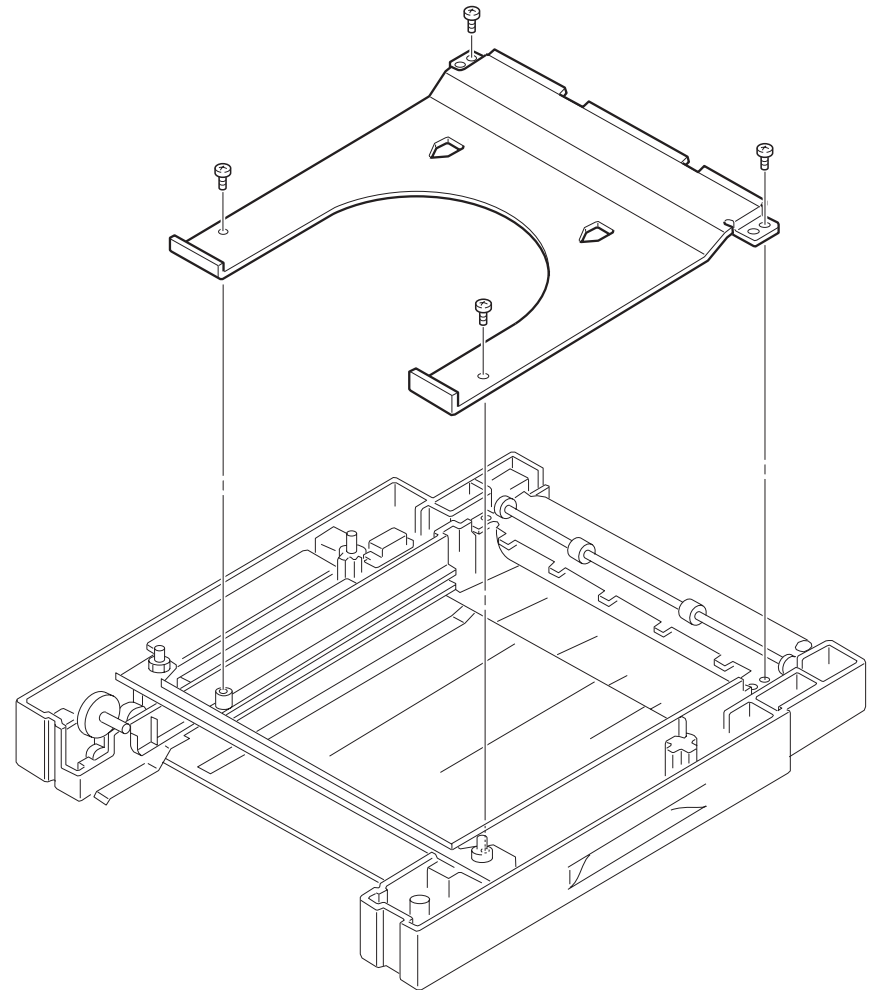

Figure 4-12. Chute Upper Removal

### 4.2.13 Sensor Assembly (Horizontal)

1. Remove the Duplex Unit.
2. Remove the Chute Assembly.
3. Remove the Plate Base.
4. Disconnect J2731 from the Sensor Assembly (Horizontal).
5. Press in on the locking clips and remove the Sensor Assembly (Horizontal) from the Chute Assembly.

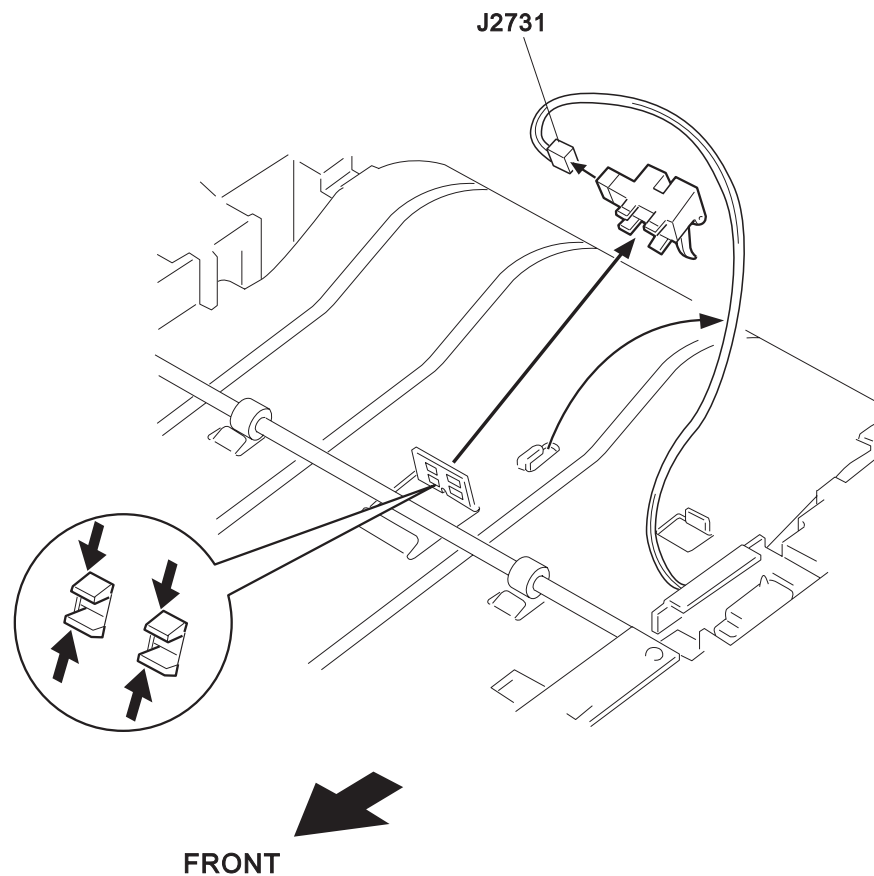

Figure 4-13. Sensor Assembly (Horizontal) Removal

### 4.2.14 Roll Assembly #1 & Pinch Roll

1. Remove the Duplex Unit.
2. Slide the end of the Plate Stopper off of the post on the Frame L/H. See illustration (1).
3. Tilt back the Duplex Assembly Unit Vertical.
4. Remove the Chute Upper.
5. Remove the two screws that are securing the Chute to the Supports Duplex R/H and L/H and remove the Chute (1).
6. Loosen the screw that secures the Rear Interlock Switch (PL11.1.8: Bracket Sensor) to the Duplex Unit Horizontal II (PL11.2) (2).
7. Remove the E-rings from both ends of Roll Assembly #1.
8. Remove the bearing from the right end of the Roll Assembly #1.
9. Remove the gear and bearing from the left end of the Roll Assembly #1.
10. Lift the shaft up and out of the Chute.
11. Slide the shaft to the right and out of the Chute.
12. Unhook and remove the two Springs that hold the Brackets Pinch to the Chute.
13. Remove the two Brackets Pinch along with the Roll Pinch from the Chute.
14. Remove the two Brackets Pinch from the ends of the Pinch Roll.

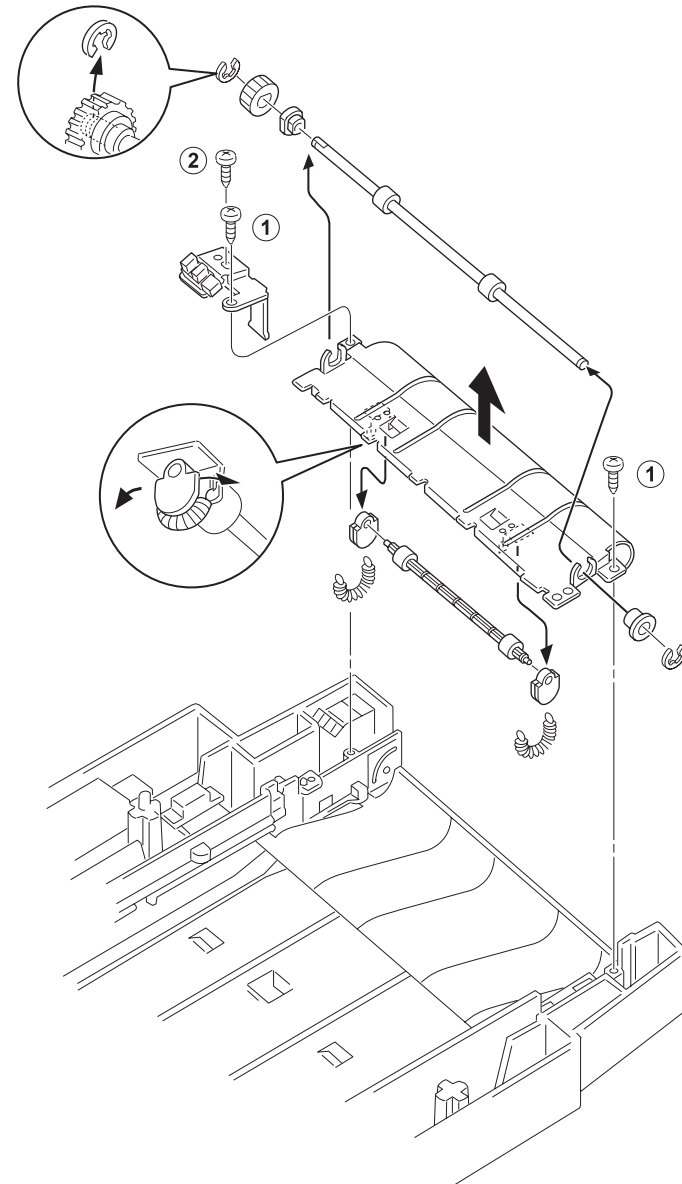

Figure 4-14. Roll Assembly #1/Pinch Roll Removal

### 4.2.15 Plate Base

1. Remove the Duplex Unit.
2. Slide the end of the Plate Stopper off of the post on the Frame L/H.  
See the illustration (1).
3. Tilt back the Vertical Unit.
4. Turn the Duplex Unit upside down.
5. Remove the eight screws that are securing the Plate Base to the Horizontal Unit, and remove the Plate Base.

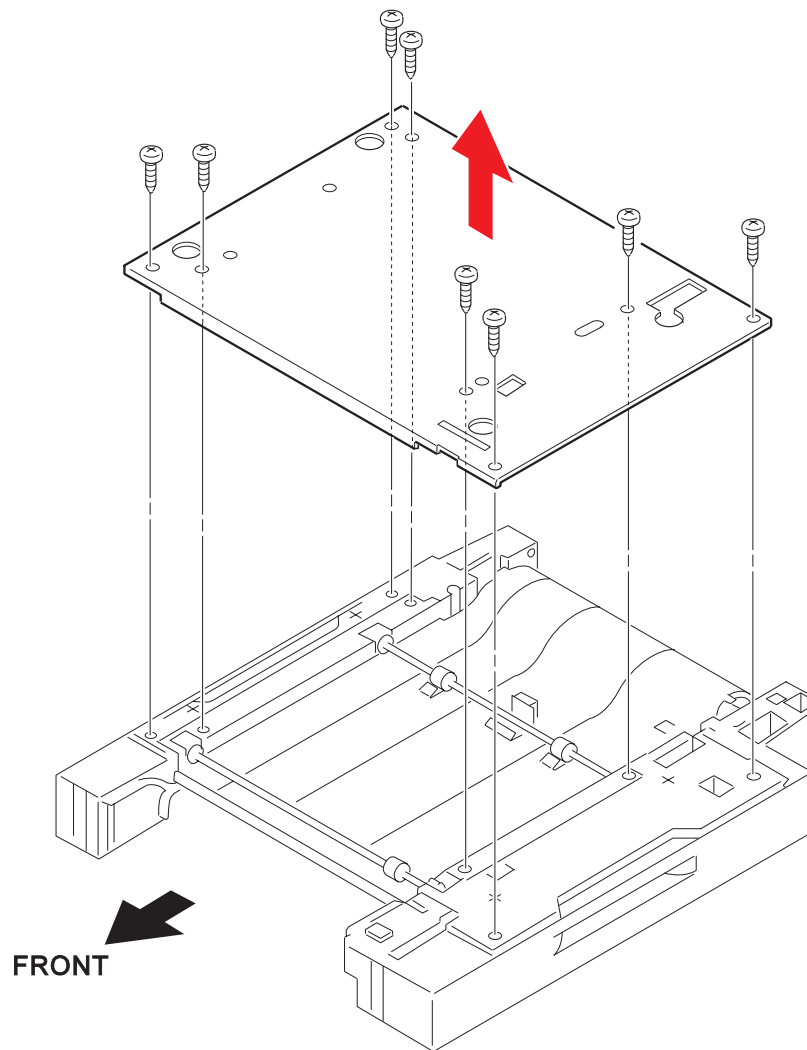

Figure 4-15. Plate Base Removal

### 4.2.16 Roll Assemblies #2 & #3

1. Remove the Duplex Unit.
2. Remove the Plate Base.
3. Set the Horizontal Unit on the Support Duplex L/H-.
4. Remove the two screws that are securing the Chute Assembly to the Support Duplex-R/H.
5. Carefully pull the Chute Assembly a few inches away from the Support.
6. Remove the E-ring from the end of Roll Assembly #2 (shaft with two rubber rolls).
7. Remove the bearing from the top end of Roll Assembly #2.
8. Slide the Roll Assembly #2 down to free the bearing at the bottom end of the Assembly.
9. Pull the top end of the Roll Assembly #2 away from the Horizontal Unit and remove the Assembly.
10. Remove the E-ring from the end of Roll Assembly #3 (shaft with one rubber roll).
11. Remove the bearing from the top end of Roll Assembly #3.
12. Slide Roll Assembly #3 down to free the bearing at the bottom end of the Assembly.
13. Pull the top end of the Roll Assembly #3 away from the Horizontal Unit and remove the Assembly.

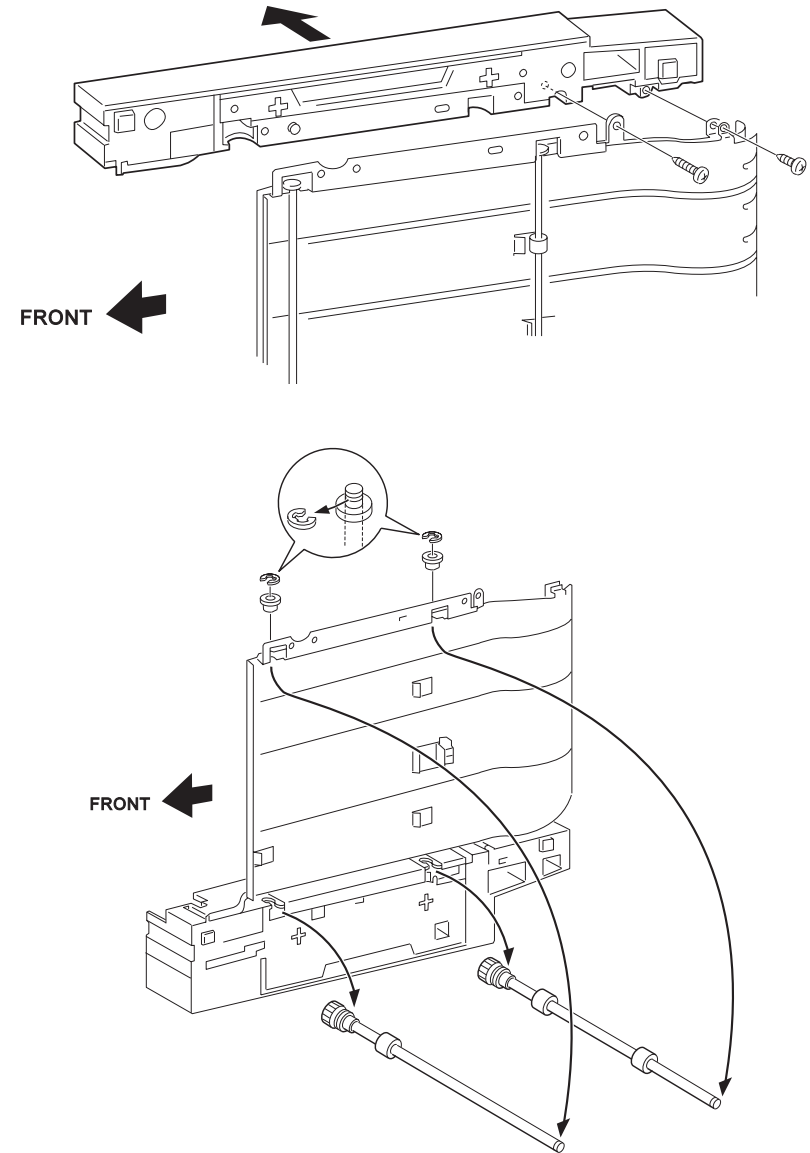

Figure 4-16. Roll Assemblies #2/#3 Removal

### 4.2.17 PWB Assembly Duplex

1. Remove the Duplex Unit.
2. Disconnect J263, J272, J273, and J274 from the PWB Assembly Duplex.
3. Remove the screw that is securing the PWB Assembly Duplex to the Support Duplex-L/H.
4. Slide the end of the PWB out of the slot in the Support Duplex L/H and remove the PWB.

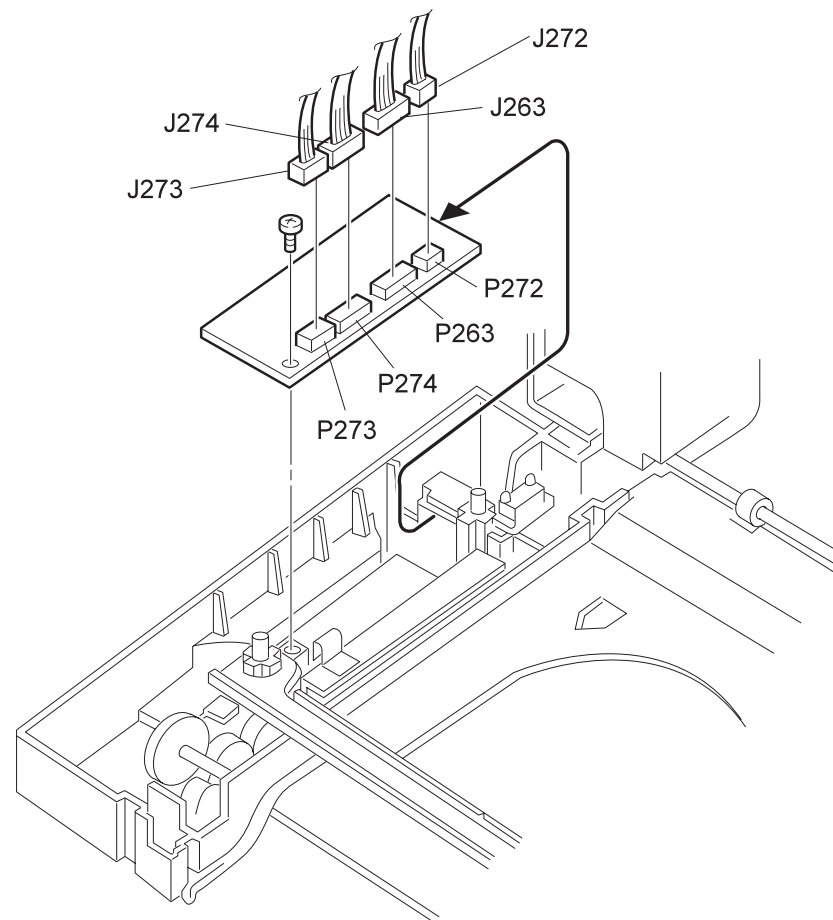

Figure 4-17. PWB Assembly Duplex Removal

### 4.2.18 Bracket & Gear Assembly

1. Remove the Duplex Unit.
2. Remove the PWB Assembly Duplex.
3. Slide the Chute Assembly out from the Duplex Unit.
4. Remove the two screws that are securing the Plate Tie to the Support Duplex-L/H and Support Duplex-R/H, and remove the Plate Tie.
5. Remove the three screws that are securing the Bracket & Gear Assembly to the Support Duplex L/H. The rear screw also secures a ground wire to the Bracket. The middle screw also secures the Bracket PWBA to the Gear Assembly Bracket.
6. Pull up and tilt back the Gear Assembly as you carefully remove the Gear Assembly from the Support Duplex L/H.



**The Gear Assembly gears are not secured to their respective shafts, and they can slide off during Gear Assembly removal. Tilt the Gear Assembly back to keep the gears in place during removal and replacement.**

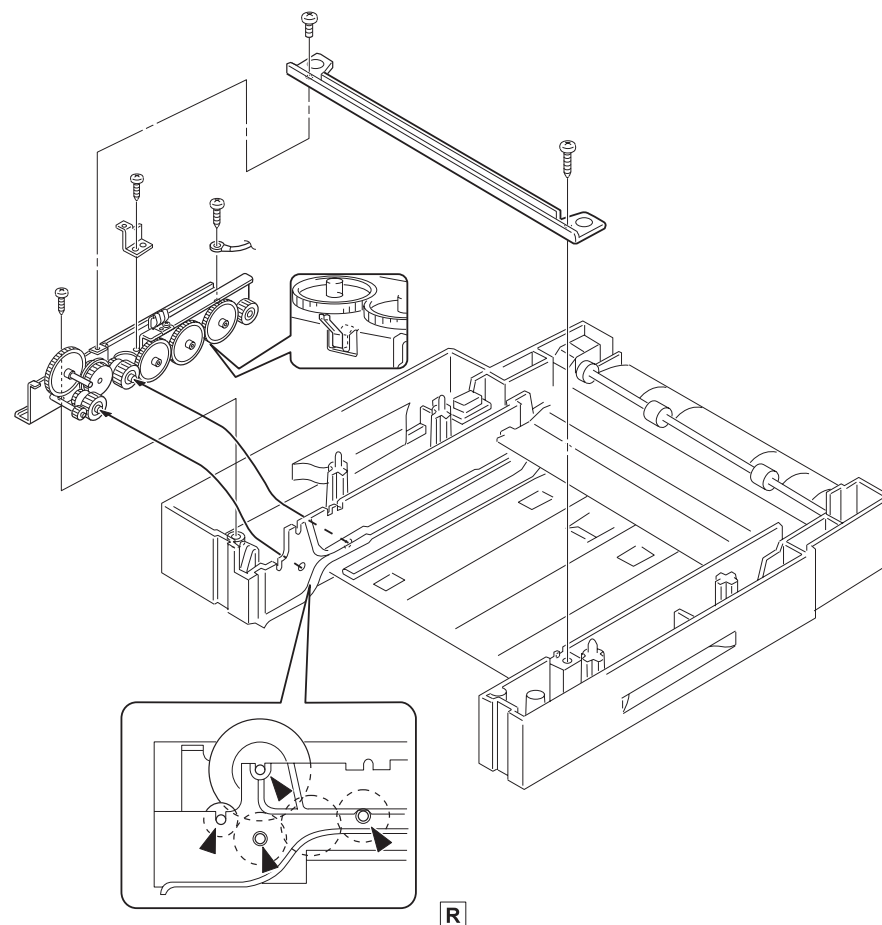

Figure 4-18. Bracket & Gear Assembly Removal

**CHAPTER**

**5**

**ADJUSTMENT**

*There is no adjustment required when repairing the Duplex Unit.*

**CHAPTER**

**6**

**MAINTENANCE**

*There is no specific maintenance required for the duplex unit.*

**CHAPTER**

**7**

**APPENDIX**

## 7.1 Connector Location

Connector	Location	Harness
J229 P/J230	6	Harness Sensor Horizontal Harness Vertical
P/J244	9	Harness Vertical
P/J246	10	Harness Vertical
P/J247 J2471	8	@ Solenoid *1 Harness Vertical
P/J249 J2491	7	@ Fan Assembly Duplex Harness Vertical
J252	5	Harness 15P
P/J263	3	Harness 15P
P/J272	4	Harness 7P
P/J273	1	Harness Sensor 9P
P/J2731	13	Harness Sensor 9P
P/J2732	11	Harness Sensor 9P
P/J2733	12	Harness Sensor 9P
P/J274	2	Harness Sensor Horizontal
P/J282	14	Harness 7P

\*1:"@" mark at the beginning of a harness name indicates that the subject harness is a part of the component from where the harness extends.

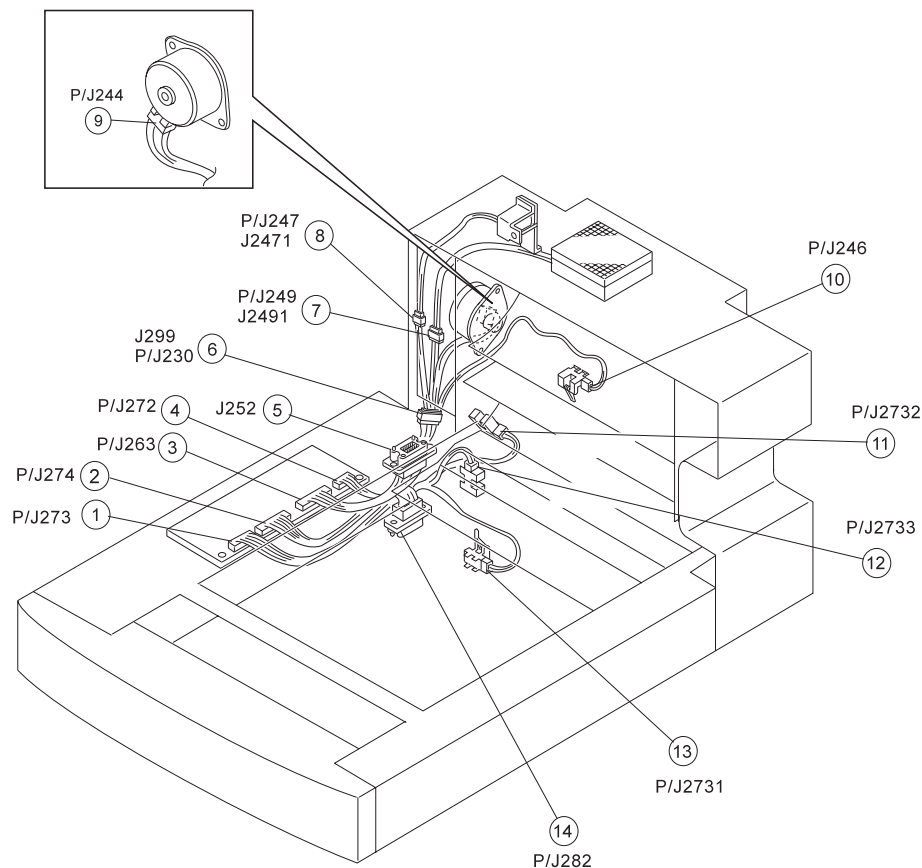

Figure 7-1. Connector Location Diagram

## 7.2 Exploded Diagram

---

### DUPLEX UNIT (OPTIONAL)

---

1. Duplex Unit  
(with PL10.2, PL10.3, PL10.4, PL11.1, PL11.2, PL12.1 and 5~8)
2. Reference only (Exploded on PL10.2, PL10.3, PL10.4)
3. Reference only (Exploded on PL11.1, PL11.2)
4. Reference only (Exploded on PL12.1)
5. Clip Chute \$
6. Chute Duplex
7. Plate Cap
8. Joint Feeder (PL9.1.22) \$

▼ 1 (with PL10.2, PL10.3, PL10.4, PL11.1, PL11.2, PL12.1 and 5~8)

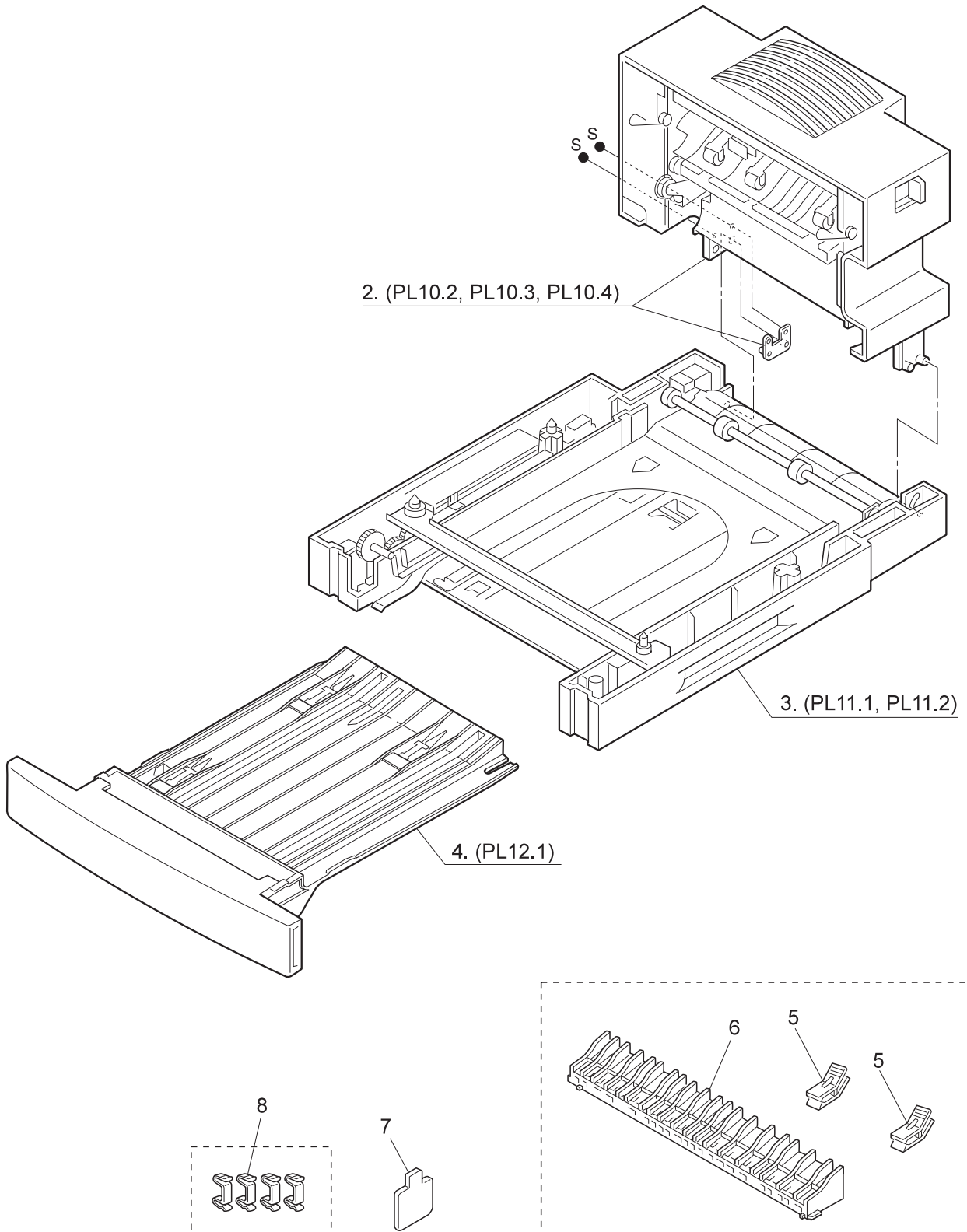

---

**DUPLEX UNIT VERTICAL I**

---

1. Duplex Assembly Unit Vertical (with 2 - 5, PL10.3, PL10.4) \$
2. Sensor Assembly \$
3. Bracket Fan
4. Fan Assembly Duplex \$
5. Chute Cover
6. --

▼ 1 (with 2~5, PL10.3, PL10.4)

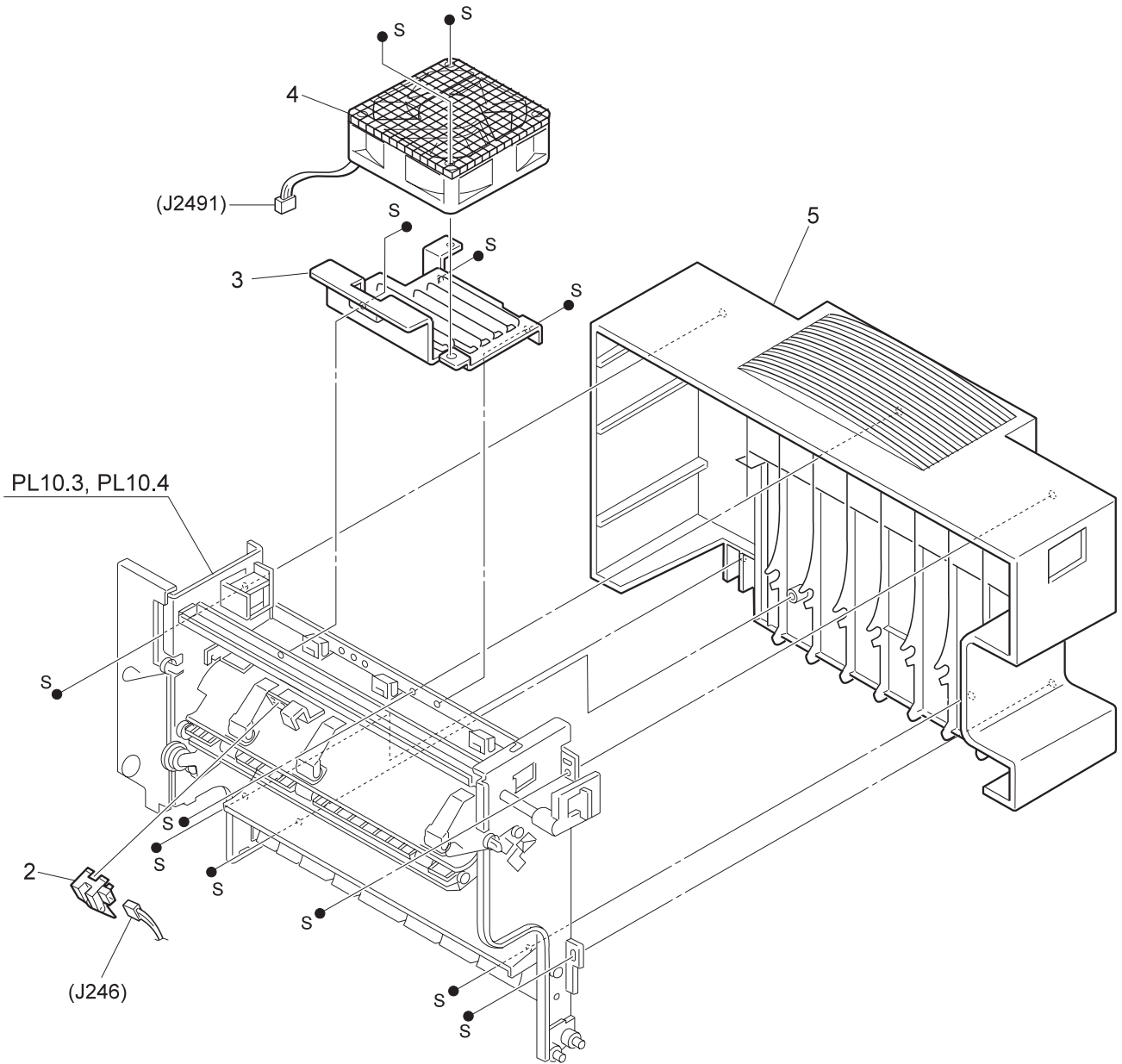

---

**DUPLEX UNIT VERTICAL II**

---

1. Harness Vertical
2. Clamp NSB1207
3. Bracket
4. Motor Duplex \$
5. Gear
6. Wire
7. Plate Cover
8. Gear
9. Spring Torsion-Latch LH
10. Gear
11. Gear
12. Frame L/H
13. Solenoid \$
14. Gear
15. Gear Idler
16. Spring Extension
17. Roll Tracking
18. Gear Idler
19. Bracket
20. Frame R/H
21. Spring Torsion-Latch RH
22. Plate Assembly Pivot

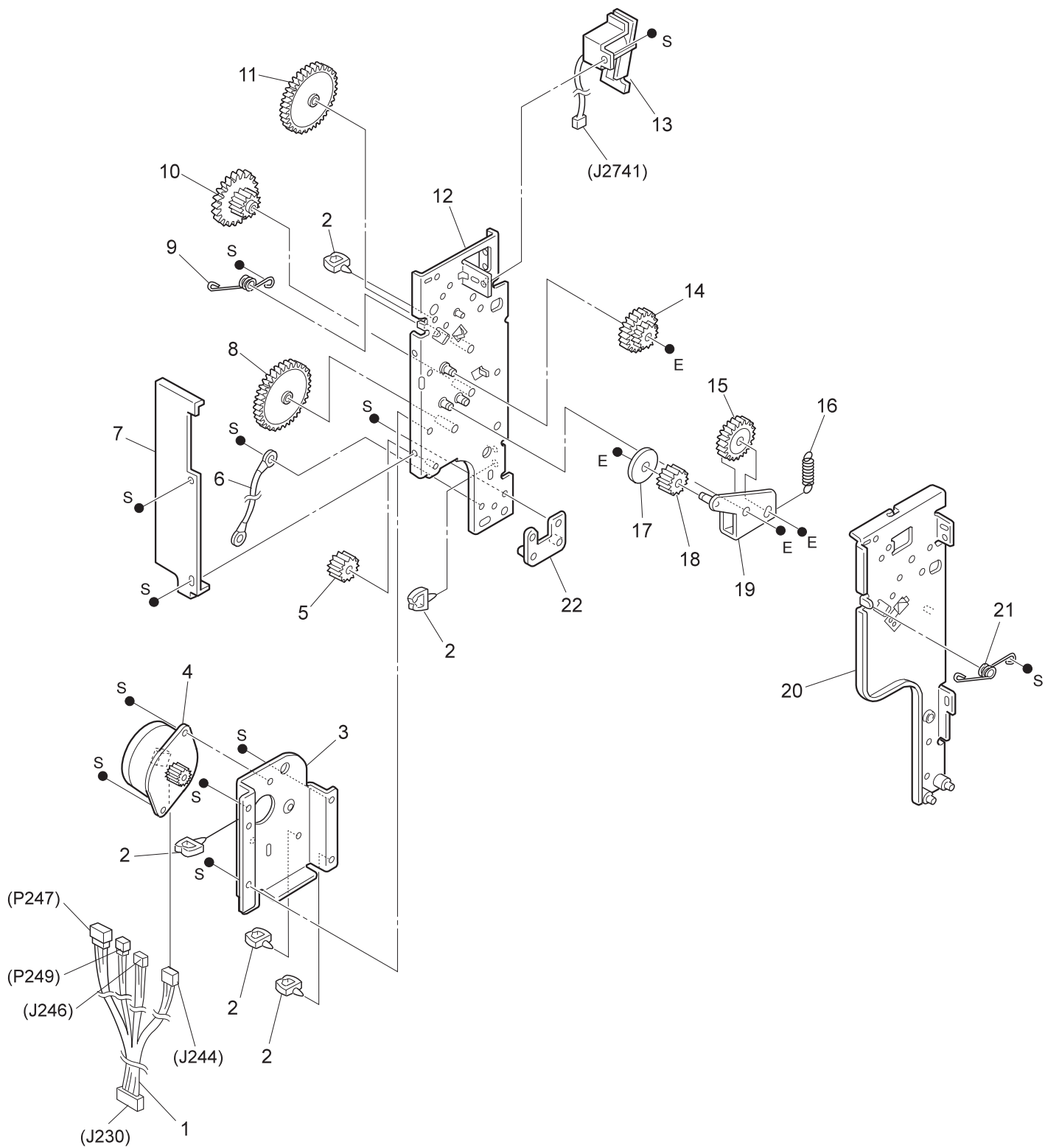

---

**DUPLEX UNIT VERTICAL III**

---

1. Chute Lower
2. Bearing
3. Roll Assembly
4. Bearing
5. Gear
6. Chute Lower
7. Spring Earth
8. Chute Invert-V/TRA
9. Chute Upper
10. Spring R
11. Spring L
12. Plate Tie
13. Roll Pinch
14. Chute Upper 2
15. Bearing
16. Gear
17. Latch
18. Shaft Latch
19. Spring
20. Roll Assembly Exit
21. Gate Upper
22. Lever
23. Bracket Pivot R/H

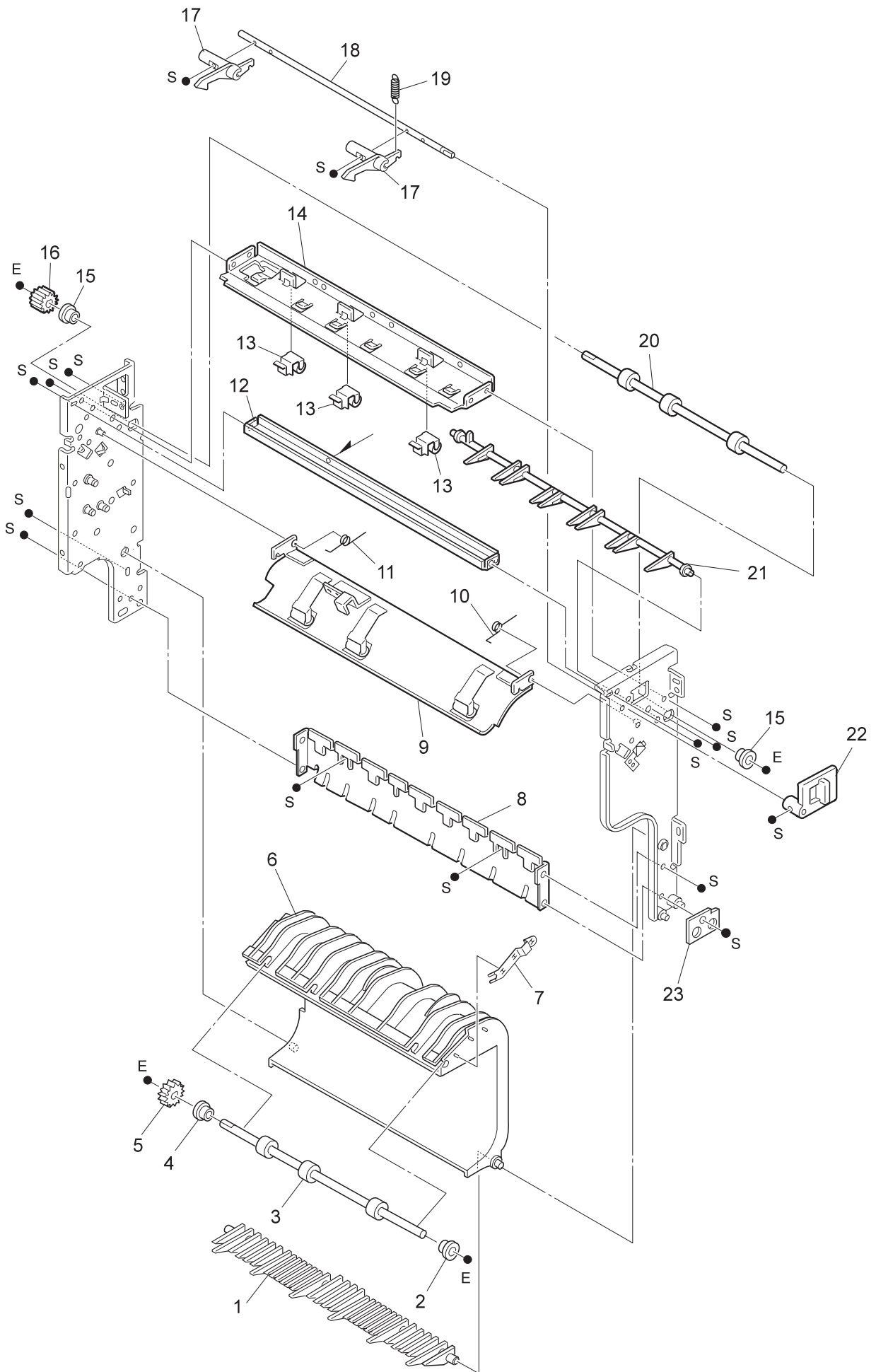

---

**DUPLEX UNIT HORIZONTAL I**

---

1. Duplex Assembly Unit Horizontal (with 2 - 24, PL11.2, PL12.1) \$
2. Roll Assembly #3
3. Roll Assembly #2
4. Chute Assembly
5. Bearing
6. Gear Z16
7. Guide
8. Bracket Sensor
9. Photo Interrupter \$
10. Chute Upper
11. GearA
12. Roll Assembly #1
13. Bearing
14. Chute
15. Bracket Pinch
16. Spring
17. Roll Pinch
18. Plate Tie
19. Chute Lower
20. Plate Pivot R/H
21. Spring Earth
22. Sensor Assembly \$
23. Support Duplex-R/H
24. Plate Base

▼ 1 (with 2~24, PL11.2, PL12.1)

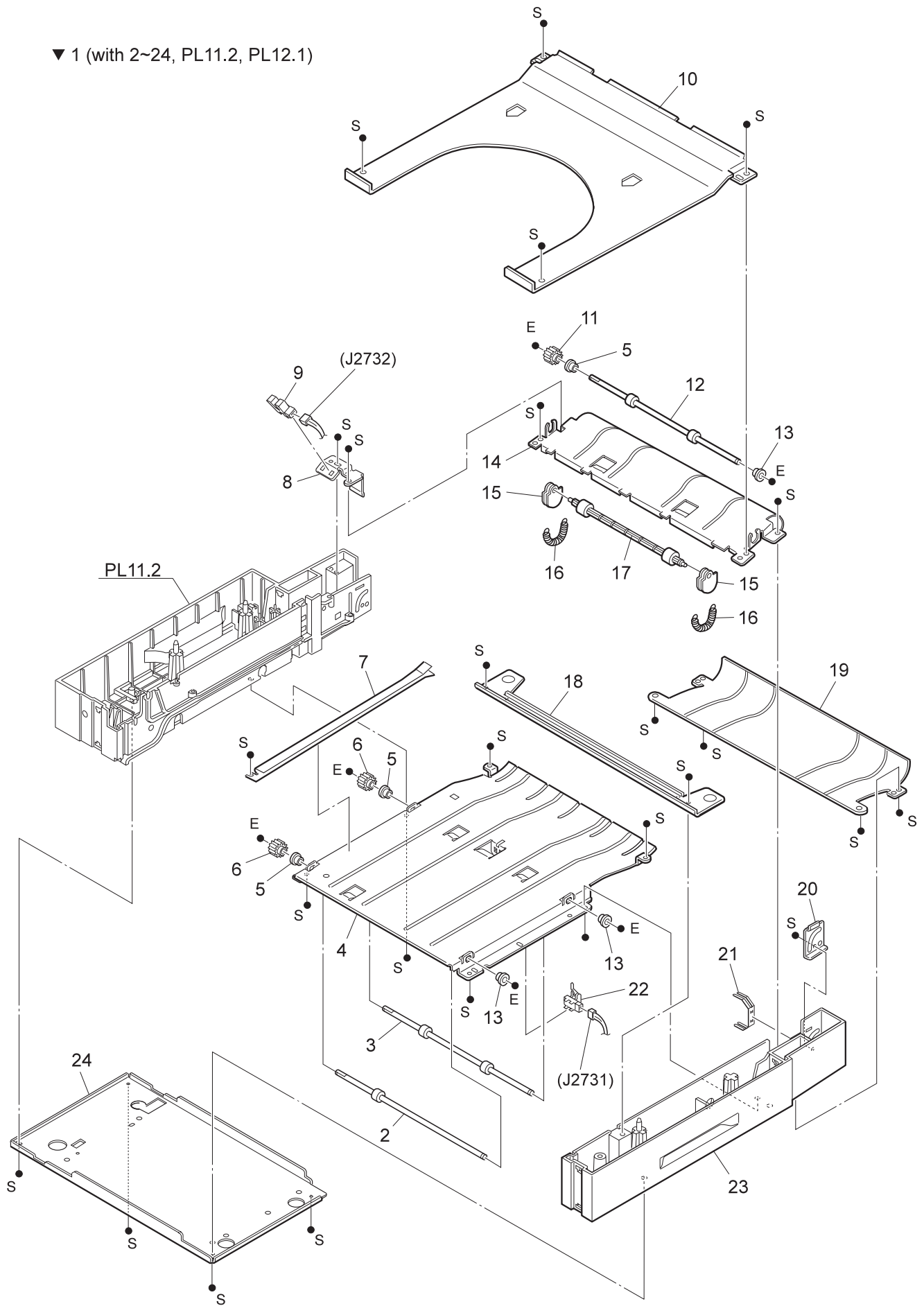

---

**DUPLEX UNIT HORIZONTAL II**

---

1. Support Duplex-L/H
2. Bracket & Gear Assembly
3. Bracket PWBA
4. Spring Earth
5. Spring Earth
6. PWBA Assembly Duplex \$
7. Harness Sensor 9P
8. Harness Sensor Horizontal
9. Plate Stopper
10. Pin
11. Harness 15P
12. Spring
13. Plate Pivot L/H
14. Harness 7P
15. Photo Interrupter \$

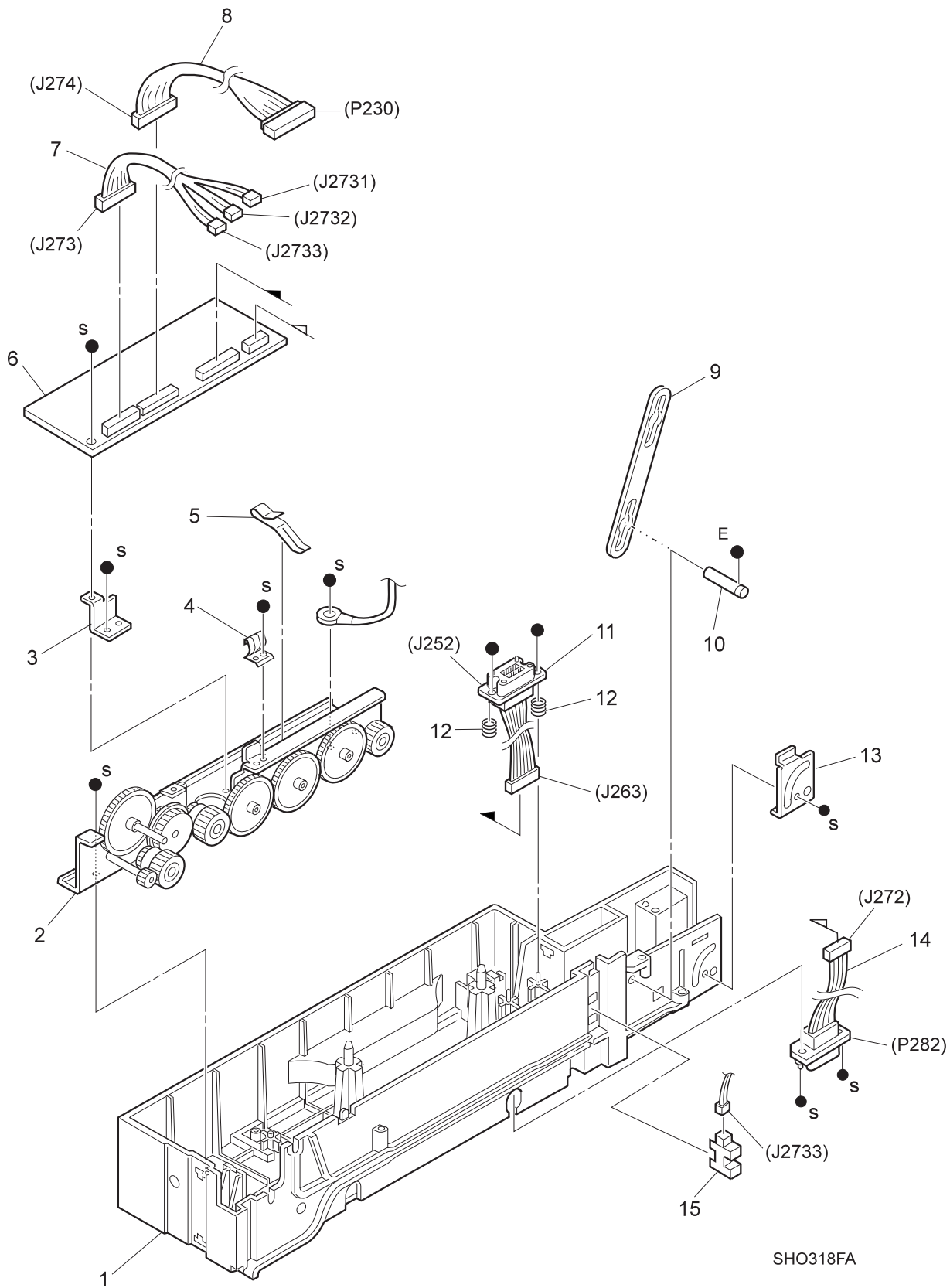

SHO318FA

---

**DUPLEX UNIT CHUTE**

---

1. Chute Assembly (with 2 - 13) \$
2. Chute
3. Roll Pinch Assembly
4. Roll Pinch Assembly
5. Chute Pass A
6. Spring Earth
7. Chute Pass B
8. Roller Assembly # 4
9. Spring Earth
10. Bearing
11. Gear Z16
12. Roll Pinch Assembly
13. Cover Front

