

SHARP SERVICE MANUAL

No. 00ZFO4700USM1

SUPPLEMENT

FACSIMILE

MODEL FO-4700

How to install the verification stamp (FO-45VS)

1. Open the operation panel unit.
2. Remove the screw (A1) x 1 pc. and open the operation panel more widely.
3. Remove the screws (B1) x 5 pcs., to remove lower document guide.
4. Remove CIS unit
 - 1) Carefully bend 2 hooks and remove CIS connector.
5. Install the verification stamp (FO-45VS) with the screw (B2) x 1pc.

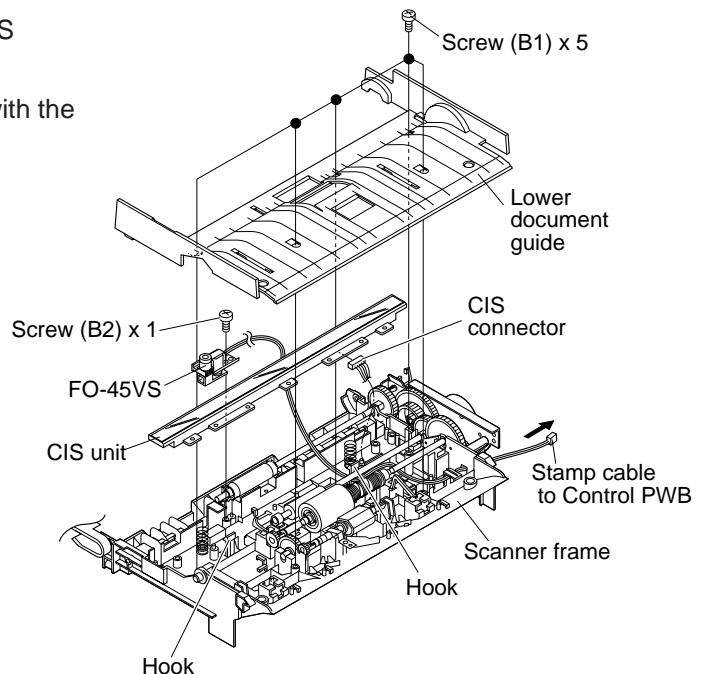
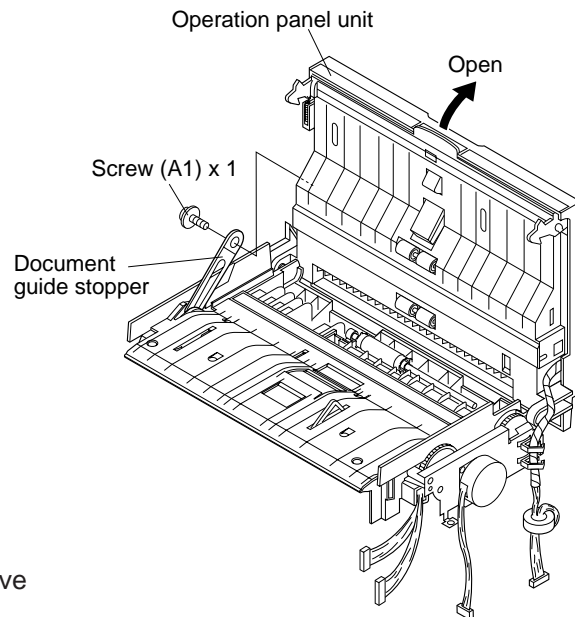

6. Wire treatment

Stamp cable must be passed through six ribs as shown in fig.1.

Connect the stamp cable to CNSTP (2 pin) of control PWB

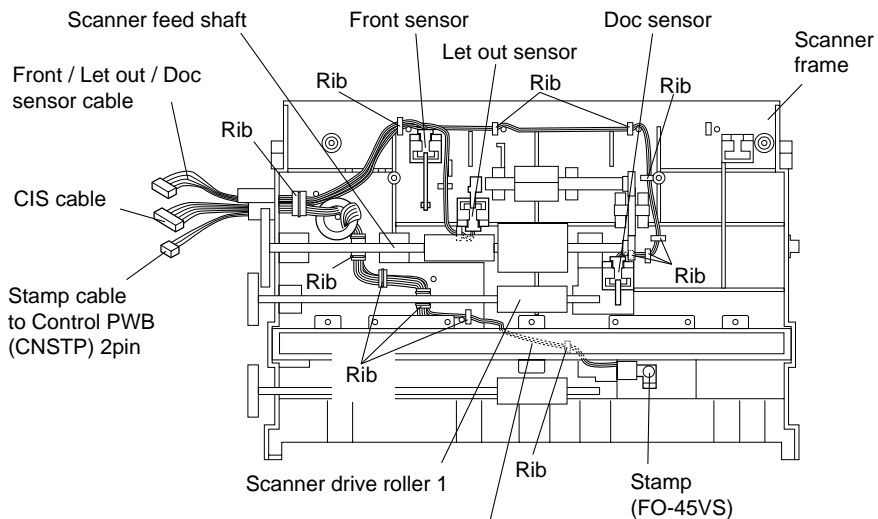

On account of the length of the stamp cable to the control PWB, it is wired at shortest.

Fig. 1

7. Soft switch setting

When you install the verification stamp (FO-45VS), set the soft SW 27. No. 3 initial setting to "1".

8. Replacing the verification stamp

If you are using the verification stamp function, you will need to replace the ink cartridge in the stamp unit when it runs out of ink (when the stamped mark on original documents becomes faint). A new ink cartridge can be obtained from your dealer.

1 Remove the original document OUT tray.

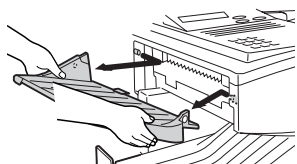

2 Press down on the protruding tab of the green ink cartridge and pull the cartridge out with your fingers.

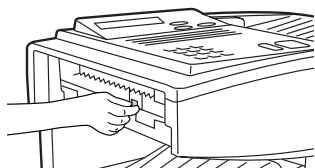

3 Insert the new ink cartridge into the machine (make sure that the tab is facing out).

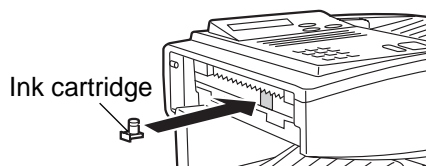

4 Replace the original document OUT tray.

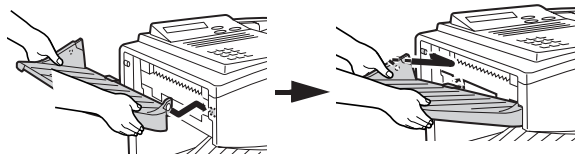

Stamp only (20 pieces)
Parts code : **UINK-2009SC01**

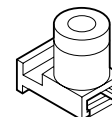

SHARP CORPORATION
Communication Systems Group
Quality & Reliability Control Center
Higashihiroshima, Hiroshima 739-0192, Japan
Printed in Japan

A9909-1832SS-IS-T