



F-8230/F-8330

PARTS LIST

Published in Mar.'00
5C470770

F-8230/F-8330

--	--	--

NOTE

1. Indicate parts number and machine model when placing an order.

eg.	Parts Number	Parts Name	Machine Model	Cycle	Quantity
	5C411430	CONTROL UNIT	F-8230/F-8330	60Hz	1

2. Service calls and freight will be charged separately.

3. Symbols in the "Parts Number" column.

- Parts with "●" indicates the service parts and the parts without "●" can not be supplied.



Parts List

F-8230/F-8330



CONTENTS

FIG. 1	F-8230(1)	2	FIG. 29	F-8230/F-8330(26)	58
FIG. 2	F-8330(1)	4	FIG. 30	F-8330(27)	60
FIG. 3	F-8230/F-8330(2)	6	INDEX		62
FIG. 4	F-8230/F-8330(3)	8				
FIG. 5	F-8230/F-8330(4)	10				
FIG. 6	F-8230/F-8330(5)	12				
FIG. 7	F-8230/F-8330(6)	14				
FIG. 8	F-8230/F-8330(7)	16				
FIG. 9	F-8230/F-8330(8)	18				
FIG. 10	F-8230/F-8330(9)	20				
FIG. 11	F-8230/F-8330(10)	22				
FIG. 12	F-8230(11)	24				
FIG. 13	F-8330(11)	26				
FIG. 14	F-8230(12)	28				
FIG. 15	F-8330(12)	30				
FIG. 16	F-8230/F-8330(13)	32				
FIG. 17	F-8230/F-8330(14)	34				
FIG. 18	F-8230/F-8330(15)	36				
FIG. 19	F-8230/F-8330(16)	38				
FIG. 20	F-8230/F-8330(17)	40				
FIG. 21	F-8330(18)	42				
FIG. 22	F-8330(19)	44				
FIG. 23	F-8330(20)	46				
FIG. 24	F-8330(21)	48				
FIG. 25	F-8330(22)	50				
FIG. 26	F-8330(23)	52				
FIG. 27	F-8330(24)	54				
FIG. 28	F-8230/F-8330(25)	56				



FIG. 1 F-8230(1)

5C4/5C5



- 2 -





41		j ø / P æ ¼ j ø / P		æ y ¼ y Ê y ¶	% FTDSJQUJPO	" ² •	U J R O E B S E	QBSUT
		"	† ? Ö ä³		/FVUSBMJ[JOH CSVTI		B #	
		\$	µ Á ç [° Ü		4UPQQFS SVCCFS		C "	
		"	FM ä		3FHVMBUJOH TIBGU		D \$	E #
		\$	· ¥ p o X		1BQFS FYJU QSFTTVSF QMBUF			F "
		\$	· X -²		1BQFS FYJU TJEF QMBUF 'SPOU			G #
		\$	· X -		1BQFS FYJU TJEF QMBUF 3FBS			
		"	4 § µ Ä "		3FJOGPSDJOH TUBZ		H # "	
		\$	M s æ		\$POUSPM VOJU		I #	
		\$	MF é " ä -		\$BSSJBHF SPMMFS		J "	
		"	MF é " ä -'		\$BSSJBHF SPMMFS 3		K #	
		\$	ž « ½ £ » -		"DUVBUPS		L %	
		\$	µ á Ä è " ç - (4MJEF SBJM -FGU		N %	
		\$	µ á Ä è " ç - É		4MJEF SBJM 3JHIU		O %	
		"	N ¥ Ä · i ±		1IPUP TFOTPS			
		"	· µ Ä ç í		1BQFS FYJU TUPQQFS			
		\$	Ú - É ç Ä © B ç ½		.BHOFU DBUDI			
		\$	' S " É		30. BTTFCMZ			
		\$	e " Ä ž " Ü		8JSJOH HVJEF BSN			
		\$	é ç « é i "		-PDL MFWFS			
		\$	- é		3PMMFS			
		\$	é ç « i É		-PDL TQSSJOH			

41 j w' 1 x ± " i µ i " Ä p b {
5IF QBSUT XBOMZ BSF BWBJMBCMF BT TQBSF QBSUT



41		j ø / P æ ¼ j ø / P		æ y ¼ y È y ¶	% FTDSJQUJPO	" 2 • % FTUJOB	U J R O B O E B S E	QBSUT
		\$	' - <		1BQFS FYJU USBZ -PXFS			B #
		\$	µ Ä ç ° Ü		4UPQQFS SVCCFS		C "	
		"	F M ä		3FHVMBUJOH TIBGU		D \$	E #
		\$	' ¥ p o X		1BQFS FYJU QSFTTVSF QMBUF			F "
		\$	' X - 2		1BQFS FYJU TJEF QMBUF 'SPOU			G #
		\$	' X -		1BQFS FYJU TJEF QMBUF 3FBS			
		"	4 \$ µ Ä "		3FJOGPSDJOH TUBZ		H # "	
		\$	M š æ		\$POUSPM VOJU		I #	
		\$	M F é " ä -		\$BSSJBHF SPMMFS		J "	
		"	M F é " ä -		\$BSSJBHF SPMMFS 3		K #	
		\$	ž « ½ £ » -		"DUVBUPS		L %	
		\$	µ ä Ä è " ç - (4MJEF SBJM -FGU		N %	
		"	µ ä Ä è " ç - E		4MJEF SBJM 3JHIU		O %	
		"	N ¥ Ä . i ±		1IPUP TFOTPS			
		"	' µ Ä ç		1BQFS FYJU TUPQQFS			
		"	Ú - È ç Ä © B ç ½		.BHOFU DBUDI			
		\$	' \$ " È		30 . BTTFNCMZ			
		"	† ? O ä ³		/FVUSBMJ[JOH CSVTI			
		\$	e " Ä ž " Ü		8JSJOH HVJEF BSN			
		\$	é ç « é i "		-PDL MFWFS			
		\$	- é		3PMMFS			
		\$	é ç « i É		-PDL TQSOJH			
		\$	r † - é		3FMFBTF SPMMFS			

41 j w ' 1 x ± " i µ i " Ä p b {
5IF QBSUT XBOMZ BSF BWBJMBCMF BT TQBSF QBSUT



41		æ ¼ j ø / P		æ y ¼ y È y ¶	% FTDSJQUJPO	% FTUJOB	UJ # O E B S E	QBSUT
\$				Ø § i" — È	4JEF DPWFS 3JHIU		B #	
\$				Ø § i" — (4JEF DPWFS -FGU		C \$	
\$				Ø § i" — í	4JEF DPWFS 6QQFS		D %	
\$				î i' X — í)JOHF QMBUF 6QQFS		E #	
\$				§ i" z # ²	'30/5 \$07&3 4*%&		F #	
\$				³"ç	4&"-		G \$	
\$				î i' X — <)JOHF QMBUF -PXFS		H #	
\$				ú	,OPC		I "	
"				ž « ½ È" »	"DUVBUPS		J #	
"				Ú — È ÷ Ä IX	.BHOFU DBUDI		K "	
\$				§ i" z ²	'30/5 \$07&3 "		L #	
"				Ú — È ÷ Ä © B ÷ ½	.BHOFU DBUDI		N "	
\$				1X	501 #0*3%		O "	
"				µ ä Ä µ Ä" —	4MJEF TUBZ "		Q \$	
\$				§ i" z TM	3&"3 \$07&3			
\$				Ä è z '	53": 1"1&3 &+&\$5			
\$				Ä è z '	53": 1"1&3 &+&\$5			
"				w-æP—	1SFWFOUJWF QBSU			
\$				N ÷ Ä · ï ±	1IPUP TFOTPS			
\$				î È — <	4QSJOH -PXFS			
"				§ i" z '	\$07&3 1"1&3 &+&\$5			
"				† ? Ö ä ³	/FVUSBMJ[JOH CSVTI			
"				'H — è —	1BQFS FYJU ESJWFO SPMFMS #			
\$				à — <	4IBGU -PXFS			
\$				† ? X	/FVUSBMJ[JOH QMBUF			
"				ž" µ X	&BSUI QMBUF			
"				H ^ ä !	%SJWFO TIBGU IPMEFS			
\$				§ È X —	4VQQPSU QMBUF "			
"				'ç ñ ž « ½ È" »	1BQFS FYJU VQ EPXO BDUVBUPS			
"				Ø Ç X	3FBS TJEF NPVOU QMBUF			
"				Ž ÷ 4 · î È ç	&YUFSOBM BVYJMJSZ QBOFM			
\$				µ ÷ ½ ^ ³" Ä	4XJUDI JOTVMBUJOH TIFFU			
\$				î" » è ÷ « µ ÷ ½	*OUFS MPDL TXJUDI			
\$				# (ç —	'/4 XJSJOH %			
#				ž « ½ È" »	"DUVBUPS			
"				· ï ± " § i"	4FOTPS DPWFS			
"				È ' § i"	4DSFX DPWFS			
\$				« TM ä Ö ç —	\$BVUJPO MBCFM "			

41]w' 'x ± "î µ" Ä p b {
5IF QBSUT X BOMZ BSF BWBJMBCMF BT TQBSF QBSUT



41		æ ¼ j ø / P		æ y ¼ y Ê y ¶		% FTDSJQUJPO		" 2 • % FTUJOB		a j æ ¼ QBSUT	
"	"	"	"	Ö"i"!i[i"èi"àç £	1BQFS	MJGU VQ MFWFS TIBGU IPMEFS #				%	B
"	"	"	"	'é"á—		1BQFS FYJU SPMFMS #				C #	
"	"	"	"	Ý»ç		.FUBM				D \$	
"	"	"	"	'é"á—		1BQFS FYJU SPMFMS "				E %	
"	"	"	"	Ñ¥Á.ĩ±		1IPUP TFOTPS				F \$	
"	"	"	"	Đīç £		1JO #				G #	
"	"	"	"	Vùæ"é"á—		\$POWFZBODF ESJWJOH SPMFMS "					H #
"	"	"	"	æ"Ö"æ— ;		%SJWJOH QVMMFZ " ;					I #
"	"	"	"	æ"ÖçÄ— -		1BQFS FYJU ESJWJOH CFMU " -				%	J
"	"	"	"	æ"Ö"æ— ;		1BQFS FYJU ESJWJOH QVMMFZ " ;					
"	"	"	"	ÖçÄ— -		#FMU & -					
"	"	"	"	Vù" ÁX—		\$POWFZBODF HVJEF QMBUF					
"	"	"	"	Vù!yiÉ		\$POWFZBODF QSFTTVSF TQSJOH					
"	"	"	"	Vù" ÁX—		\$POWFZBODF HVJEF QMBUF					
"	"	"	"	Où{ \$á"		%PVCMF GFFE GJYFE DPMFMS					
"	"	"	"	" ÁX—		1BQFS FYJU HVJEF QMBUF \$					
"	"	"	"	Vù" ÁX—		\$POWFZBODF HVJEF QMBUF					
"	"	"	"	%ø èi"—		0QFO DMPTF MFWFS					
"	"	"	"	%ø èi"—		0QFO DMPTF MFWFS					
"	"	"	"	" ÁX—		1BQFS FYJU HVJEF QMBUF "					
"	"	"	"	ÇVÉ'		4IPVMEFS TDSFX					
"	"	"	"	" ÁX—		1BQFS FYJU HVJEF QMBUF #					
"	"	"	"	%ø èi"—		0QFO DMPTF MFWFS					
"	"	"	"	æ"Ö"æ— ;		%SJWJOH QVMMFZ # ;					
"	"	"	"	Ö"±-é		&OUSBODF SPMFMS					
"	"	"	"	Vù!yà— Ê		\$POWFZBODF QSFTTVSF TIBGU # BTTFNCMZ					
"	"	"	"	Vù!yiÉ		\$POWFZBODF QSFTTVSF TQSJOH					
"	"	"	"	Äi³äiä!		5FOTJPO TIBGU IPMEFS					
"	"	"	"	µÄç!°Ü		4UPQQFS SVCCFS					
"	"	"	"	.i±É		1BQFS FYJU TFOTPS BTTFNCMZ					
"	"	"	"	#(ç—		1/4 XJSJOH #					
"	"	"	"	Ø"çÖžæi-ç £		#BMM CFBSJOH #					
"	"	"	"	Đīç £		1JO "					

41]w' 'x±"iui"Äbb{
5IF QBSUT XBOMZ BSF BWBJMBCMF BT TQBSF QBSUT



41		P		æy¼yËy¶		%FTDSJQUJPO		%FTUJOB		5C4/5C5	
jø	3FG	æ ¼ j ø	P	æy¼yËy¶				" 2 •	UJROB	æ ¼	QBSUT
"		"		Ý»ç		.FUBM				B %	
"		\$		§ËX		4VQQPSU QMBUF				C %	
"		\$		Vùé"á—		\$POWFZBODF SPMMF\$				D "	
"		\$		Vùé"á—		\$POWFZBODF SPMMF\$ #				E #	
"		\$		Vù!yiË		\$POWFZBODF QSFTTVSF TQSJOH				G #	F "
"		"		Ù-É¿Ä@B¿½		.BHOFU DBUDI				H #	
"		\$		ír'íË—)JOHF TQSJOH \$				I "	
"		\$		ír'íË—)JOHF TQSJOH %				K #	
"		"		rtèi"m±^		3FMFBTF MFWFS LOPC					
"		"		Ëj[µÄ"		-JGU VQ TUBZ					
"		\$		rtËÖ		3FMFBTF LOPC					
"		"		Ö"±é		&OUSBODF SPMMF\$					
"		\$		Vù" ÁX—		\$POWFZBODF HVJEF QMBUF #					
"		"		Vù!yá— Ë		\$POWFZBODF QSFTTVSF TIBGU # BTTFCMZ					
"		\$		'S°æP		1BQFS HVJEF QBSU					
"		\$		Vù" ÁX—		\$POWFZBODF HVJEF QMBUF "					
"		"		µÄ¿i°Ü		4UPQQFS SVCCFS					
"		\$		Vùé"á—		\$POWFZBODF SPMMF\$ "					
"		"		N¥Ä·i±		1IPUP TFOTPS					
"		"		'èË ÄiË		4PMFOPJE TQSJOH					
"		"		UË·i±"—		%FUFDUJOH TFOTPS					
"		"		Ö"í"!í[èi"à!ç ε	1BQFS	MJGU VQ MFWFS TIBGU IPMEFS #					

41]w' 'x±"íµí"Äpb{
5IF QBSUT XBOZ BSF BWBJMBCMF BT TQBSF QBSUT



41		æ ¼ j ø		æ y ¼ y È y ¶		%FTDSJQUJPO		" 2 •		a j æ ¼		QBSUT	
3FG /P		1BSUT /P						%FTUJOB		UJROB		EBSÈ	
"	"	"	"	rtèi"m±^	3	FMFBTF MFWFS LOPC				B "			
"	"	"	"	Èj[µÄ"	-	JGU VQ TUBZ				C #			
"	"	"	"	Ü-È¿Ä@B¿½		.BHOFU DBUDI				D #			
"	"	"	"	Vù!yàÉ		\$POWFZBODF QSFTTVSF TIBGU BTTFNCMZ							E "
"	"	"	"	Vù!yiÉ		\$POWFZBODF QSFTTVSF TQSJOH							F %
"	"	"	"	Vù-é		\$POWFZBODF SPMMFS				G %			
"	"	"	"	µÄ¿!°Ü	4	UPQQFS SVCCFS				H "			
"	"	"	"	Vù" ÅX—		\$POWFZBODF HVJEF QMBUF %							I #
"	"	"	"	Uœ.i±"—		%FUFDUJOH TFOTPS				J "			
"	"	"	"	.i±\$i"	4	FOTPS DPWFS							
"	"	"	"	Ñ¥Ä.i±	1	PUP TFOTPS							
"	"	"	"	Vù" ÅX—		\$POWFZBODF HVJEF QMBUF '							
"	"	"	"	îi'îÉ—)	JOHF TQSJOH "							
"	"	"	"	îi'îÉ—)	JOHF TQSJOH #							
"	"	"	"	Vù" ÅX—		\$POWFZBODF HVJEF QMBUF &							
"	"	"	"	Vù" ÅX—		\$POWFZBODF HVJEF QMBUF \$							
"	"	"	"	!èÉ ÅiÉ	4	PMFOPJE TQSJOH							
"	"	"	"	Š°ä—		(VJEF TIBGU "							
"	"	"	"	Š°ä—		(VJEF TIBGU #							
"	"	"	"	'é"ä"—	1	BQFS FYJU SPMMFS "							
"	"	"	"	Ö"i"!i[èi"à!ç £	1	BQFS MJGU VQ MFWFS TIBGU IPMEFS #							
"	"	"	"	Ý»ç		.FUBM							
"	"	"	"	Vùé"ä—		\$POWFZBODF SPMMFS \$							
"	"	"	"	¥Vpo°Ü		1SFTTVSF SVCCFS							
"	"	"	"	Vù4•šà"		\$POWFZBODF BVYJMJB SZ DPMMBS							
"	"	"	"	Đi	1	JO #							

41]w' 1x±"iµi"Äpb{
5IF QBSUT XBOMZ BSF BWBJMBCMF BT TQBSF QBSUT



41		æ ¼ j ø		P		æ y ¼ y Ê y ¶		%FTDSJQUJPO		" 2 •		UJROBEOEBSE		QBSUT	
		"	µ à	À à				4MJEF TIBGU				B %			
		"	- é					3PMMFS				C #			
		\$	µ à	À µ À ç í —				4MJEF TUPQQFS "				D %			
		\$	ç ñ µ À "					6Q EPXO TUBZ				F #			
		\$	ç ñ § í —					6Q EPXO DPWFS 3				G %			
		\$	ç ñ § í —					6Q EPXO DPWFS '				H "			
		\$	À è z ' ç ñ					53 : 1"1&3 &+&\$5 -*'5				I #			
		\$	À è z ' ç ñ					53 : 1"1&3 &+&\$5 -*'5				J "			
		\$	' 4 § µ À "					1BQFS FYJU SFJOGPSDJOH TUBZ							N "
		\$	æ ^ b , " à ! ç £					%SJJWJOH TMJEF TIBGU IPMEFS "							O #
		"	ç ñ ^ z — ;					6Q EPXO HFBS \$;							
		"	Ð ï					1JO \$							
		"	À ï ^ à ï Ó " æ					5FOTJPO QVMMFZ							
		"	À ï ^ à ï X § ^ Ý					5FOTJPO QMBUF DPNCJOFE							
		\$	ç ñ è à —					6Q EPXO XJSF 3							
		\$	ç ñ è à —					6Q EPXO XJSF '							
		\$	4 • X					"VYJMJBSZ QMBUF							
		"	† ? Ó à ^					/FVUSBMJ[JOH CSVTI							
		"	Ý » ç					.FUBM							
		"	ç ñ ^ z — ;					6Q EPXO HFBS " ;							
		"	ç ñ ^ z — ;					6Q EPXO HFBS # ;							
		\$	b " » Ê					.PUPS BTTFNCMZ							
		"	ç ñ Ó " æ					6Q EPXO QVMMFZ							

41 j w ' 1 x ± " ï µ í " À p b {
5IF QBSUT XBOMZ BSF BWBJMBCMF BT TQBSF QBSUT



5C4/5C5

41	jø 3FG	/P æ ¼ j ø 1BSUT /P	æy¼yËy¶	%FTDSJQUJPO	" 2 • %FTUJOB	a j æ ¼ UJROBŒEBSË	QBSUT
		"	³ÑÃþ"»"Ê	4IJGU NPUPS BTTFNCMZ			B %
		"	þ"» "ÇZX	PUPS NPVOU QMBUF		C %	
		"	Ñ¥Ã·ĩ±	1IPUP TFOTPS		D %	
		"	à!—	4IBGU IPMEFS "		E "	
		"	µá ÄµÄ"— §³Ý	4MJEF TUBZ " DPNCJOFE		G #	F "
		"	Š°X	(VJEF QMBUF		#	H
		"	Ö"í"!í[è]"à!ç £	1BQFS MJGU VQ MFWFS TIBGU IPMEFS #		I %	
		"	µá Äaz— ;	4MJEF HFBS # ;		J #	
		"	µá Äaz— ;	4MJEF HFBS # ;		K "	
		"	µá Äz"Ü	4MJEF BSN		N #	L "
		"	Vù!y!É	\$POWFZBODF QSFTTVSF TQSJOH			
		"	¥Vpo³"Ä	1SFSTTVSF TIFFU			
		"	Vùµá Äà	\$POWFZBODF TMJEF TIBGU			
		"	Vù!y!àÉ	\$POWFZBODF QSFTTVSF TIBGU BTTFNCMZ			
		"	¥Vpo-é	1SFSTTVSF SPMMFS			
		"	µá Äaz— ;	4MJEF HFBS \$;			
		"	· ÄX—<	(VJEF QMBUF -PXFS			
		"	Ö"±-é	&OUSBODF SPMMFS			

41]w' ¹x±"íµí"Äþb{
5IF QBSUT XBO MZ BSF BWBJMBCMF BT TQBSF QBSUT



41		P		æy¼yËy¶		%FTDSJQUJPO		5C4/5C5		QBSUT	
3FG	P	æ	¼	j	ø			%FTUJOB	UJ	æ	¼
"	"	"	"	"	"	4PMFOPJE BTTFNCMZ			B #		
"	"	"	"	"	"	1BQFS FYJU BTTFNCMZ			C "		D #
"	"	"	"	"	"	4PMFOPJE NPVOU QMBUF			E %		
"	"	"	"	"	"	4PMFOPJE TQSJOH			F #		G "
"	"	"	"	"	"	4PMFOPJE MFWFS			H "		
"	"	"	"	"	"	1BQFS FYJU HVJEF TUBZ			I \$		
"	"	"	"	"	"	4MJEF BSN					
"	"	"	"	"	"	4UJDLJOH QBSU					
"	"	"	"	"	"	1JO #					
"	"	"	"	"	"	1BQFS FYJU DPOWFZBODF TIBGU					
"	"	"	"	"	"	1BQFS FYJU TVQQPSU TIBGU					
"	"	"	"	"	"	1BQFS FYJU SPMMFS					
"	"	"	"	"	"	1BQFS FYJU HVJEF TUBZ #					
"	"	"	"	"	"	3PUBSZ TUPQQFS					
"	"	"	"	"	"	1BQFS MJGU VQ MFWFS TIBGU IPMEFS #					
"	"	"	"	"	"	4IBGU IPMEFS					
"	"	"	"	"	"	1BQFS FYJU QSFTTVSF TQSJOH					
"	"	"	"	"	"	1BQFS FYJU HVJEF TUBZ					
"	"	"	"	"	"	/FVUSBMJ[JOH CSVTI					
"	"	"	"	"	"	1BQFS FYJU HVJEF QMBUF 6QQFS					
"	"	"	"	"	"	1BQFS FYJU HVJEF TIFFS					
"	"	"	"	"	"	1BQFS FYJU HVJEF QMBUF .JEEMF					
"	"	"	"	"	"	4UPQQFS					
"	"	"	"	"	"	1IPUP TFOTPS					
"	"	"	"	"	"	4FOTPS DPWFS BTTFNCMZ					
"	"	"	"	"	"	1BQFS HVJEF QMBUF .JEEMF BTTFNCMZ					
"	"	"	"	"	"	.FUBM					

41]w' 1x±"iú"Äpb{
5IF QBSUT XOMZ BSF BWBJMBCMF BT TQBSF QBSUT



5C4/5C5

41	jø 3FG	P æ ¼ j ø 1BSUT /P	æ y ¼ y È y ¶	%FTDSJQUJPO	" 2 • %FTUJOB	a j æ ¼ UJROBOEBSE	QBSUT
		"	7"æP	4UJDLJOH QBSU		B %	
		"	Ö"i"!i[è]"à!ç £	1BQFS MJGU VQ MFWFS TIBGU IPMEFS #		#	C
		"	'æ"à	1BQFS FYJU ESJWJOH TIBGU		F #	E "
		"	'éµá—	1BQFS FYJU SPMMFS "			
		"	'" AX	1BQFS FYJU HVJEF QMBUF			G %
		"	sØX\$³YÈ	3PUBSZ EJTL BTFNCMZ			H #
		"	'Óµæµ— ;	1BQFS FYJU QVMMFZ " ;			
		"	'...æ"p"»	1BQFS GFFE ESJWJOH NPUPS			
		"	bµ»µÓµæ ;	.PUPS QVMMFZ ;			
		"	ÖçÄ— -	#FMU # -			
		"	ÖçÄ— -	#FMU ' -			
		"	à!ç £	4IBGU IPMEFS "			
		"	Y»ç	.FUBM			
		"	æ"Óµæ— ;	%SJWJOH QVMMFZ " ;			
		"	'Óµæ— ;	1BQFS FYJU QVMMFZ # ;			
		"	\$âµ—	\$PMMBS "			
		"	'IÈ	1BQFS FYJU TQSOH			

41]w' 1x±"iµi"Äpb{
5IF QBSUT XBOMZ BSF BWBJMBCMF BT TQBSF QBSUT





41		æ ¼ j ø / P		æ y ¼ y Ê y ¶	% FTDSJQUJPO	% FTUJOB	UJ R O B O E B S E	QBSUT
\$	V ù b " »	\$POWFZBODF NPUPS	B %					
"	p " » Ó " æ	. PUPS QVMMFZ	C #					
\$	Ó ç Á — -	#FMU " -	D %					
"	Ý » ç	. FUBM	E "					
\$	µ á Á º ž — ;	4MJEF HFBS " ;	F %					
\$	V ù æ " Ó " æ — ;	\$POWFZBODF ESJWJOH QVMMFZ " ;	G #					
\$	Ó ç Á — -	#FMU # -	H #					
"	' á á ;	1BQFS FYJU HFBS ;						
"	Ð ï ç £	1JO "	J #					
"	æ " Ó " æ —	%SJWJOH QVMMFZ %	K #					
"	À ç £	(FBS &	L \$					
\$	Ó " æ ! Q æ P	1VMMFZ IPMEJOH QBSU						
\$	µ á Á Ó " æ ;	4MJEF QVMMFZ ;						
"	N º Á · ï ±	1IPUP TFOTPS						
\$	æ " Ê Á º ž ;	%SJWJF DPOOFDUJOH HFBS ;						
\$	' Ó " æ ;	1BQFS FYJU QVMMFZ ;						
\$	À ï º á ï é	5FOTJPO SPMMFS						
\$	' æ " Ó ç Á — -	1BQFS FYJU ESJWJOH CFMU # -						
"	Ó ç Á — -	#FMU & -						
"	\$ á " —	\$PMMBS "						
"	à ! ç £	4IBGU IPMEFS "						
\$	æ " Ó " æ — ;	%SJWJOH QVMMFZ " ;						
"	º N Á b " » " Ê	4IJGU NPUPS BTTFNCMZ						
\$	Ó ç Á Á ï º á ï é	#FMU UFOTJPO SPMMFS						

41 j w ' 1 x ± " i µ i " Á p b {
5IF QBSUT X B O M Z B S F B W B J M B C M F B T T Q B S F Q B S U T





41		j ø / P æ ¼ j ø / P		æ y ¼ y È y ¶	% FTDSJQUJPO	" 2 •	UJ R O B O E B S E	QBSUT
		"		æ ^ Ö " æ — ;	% SJWJOH QVMMFZ \$;			B %
		"		Y » ç	. FUBM		C #	
		\$		æ ^ Ö " æ — ;	% SJWJOH QVMMFZ \$;			D #
		"		æ ^ Ö " æ — ;	% SJWJOH QVMMFZ " ;			
		\$		Ö ç Ä — -	# FMU % -			
		"		Ö ç Ä — -	# FMU \$ -			
		"		Ö ç Ä Ä i ³ ä i È	# FMU UFOTJPO TQSJOH			
		"		7 " æ P	4UJDLJOH QBSU			
		"		# (' è È Ä È	' / 4 TPMFOPJE BTTFNCMZ			
		\$		à ! ç £	4IBGU IPMEFS "			
		"		Ö ç Ä — -	# FMU # -			
		\$		æ ^ Ö ç Ä — -	1BQFS FYJU ESJWJOH CFMU # -			
		"		' è È Ä è l "	4PMFOPJE MFWFS			

41 j w ' 1 x ± " i u i " Ä p b {
5IF QBSUT X B O M Z B S F B W B J M B C M F B T T Q B S F Q B S U T





41		P		æy¼yËy¶		%FTDSJQUJPO		" 2 • UJ#R#B#OEBSE QBSUT	
		"	æ^Ó"æ— ;		%SJWJOH QVMMFZ \$;				B %
		"	Y»ç		.FUBM			C #	
		\$	æ^Ó"æ— ;		%SJWJOH QVMMFZ \$;				D #
		"	æ^Ó"æ— ;		%SJWJOH QVMMFZ " ;				
		\$	ÓçÄ— -		#FMU % -				
		\$	ÓçÄ— -		#FMU \$ -				
		\$	ÓçÄÄi³äiË		#FMU UFOTJPO TQSJOH				
		"	7"æP		4UJDLJOH QBSU				
		"	iË		4QSJOH				
		"	#('èË ÄË		4 TPMFOPJE BTTFNCMZ				
		"	à!ç £		4IBGU IPMEFS "				
		\$	ÓçÄ— -		#FMU # -				
		\$	'æ^ÓçÄ— -		1BQFS FYJU ESJWJOH CFMU # -				
		"	'èË Äèi"		4PMFOPJE MFWFS				

41]w' 'x±"iü"Äpb{
5IF QBSUT XBOMZ BSF BWBJMBCMF BT TQBSF QBSUT



41		P		P		%FTDSJQUJPO		5C4/5C5	
jø	3FG	æ ¼ j ø	1BSUT	æ y ¼ y È y ¶			" 2 •	a j æ ¼	QBSUT
\$		\$		\$"Aæç'š°è"ç	\$BSUSJEHF HVJEF TFBM			B \$	
\$		\$		à\$ÈX—	4IBGU TVQQPSU QMBUF \$				C %
"		"		N¥Á·î±	1IPUP TFOTPS			D #	
\$		\$		MFSi"—(\$BSSJBHF DPWFS -FGU			E "	
"		"		íÉç—²	1BOFM 'SPOU			F #	
\$		\$		ú	,OPC			G "	
\$		\$		éç«\$Û	-PDL DBN			H #	
\$		\$		íÉç—	1BOFM 3FBS			I #	
\$		\$		à\$ÈX—	4IBGU TVQQPSU QMBUF #				
\$		\$		¤',XæÈ	3FMBZ CPBSE BTTFNCMZ				
\$		\$		MFSi"—í	\$BSSJBHF DPWFS 6QQFS				
\$		\$		ÓçÁ{ Óéç«	#FMU GJYFE CMPDL				
\$		\$		µÁ Óçs8"é	4UBQMF SPUBSZ SPMMFS				
\$		\$		çs8X—	8JSJOH SPUBSZ QMBUF				
\$		\$		FMíçÁ	3FHVMBUJOH QBE				
\$		\$		§i"—È	\$PWFS 3JHIU				

41]w' 1x±"íi"Ápb{
5IF QBSUT XBOMZ BSF BWBJMBCMF BT TQBSF QBSUT





41		P		æy¼yËy¶		%FTDSJQUJPO		" 2 •		a j æ ¼		5C4/5C5	
j ø / 3FG		P 1BSUT / P		æy¼yËy¶		%FTDSJQUJPO		%FTUJOB		UJ#O#OEBS		QBSUT	
		\$	\$	\$"Åæç'Š°è"ç		\$BSUSJEHF HVJEF TFBM				B \$			
		\$	\$	MF\$!"—(\$BSSJBHF DPWFS -FGU				C %			
		"	"	ÍËç—²		1BOFM 'SPOU				D #			
		\$	\$	ú		.OPC				E "			
		\$	\$	éç « §Ü		-PDL DBN				F #			
		\$	\$	ÍËç—		1BOFM 3FBS				G "			
		\$	\$	à\$ËX—		4IBGU TVQQPSU QMBUF #						H #	
		\$	\$	¤',XæË		3FMBZ CPBSE BTTFNCMZ						I #	
		\$	\$	MF\$!"—í		\$BSSJBHF DPWFS 6QQFS							
		\$	\$	ÖçÄ{ Öéç «		#FMU GJYFE CMPDL							
		\$	\$	µÄ Öçs8-é		4UBQMF SPUBSZ SPMMFS							
		\$	\$	çs8X—		8JSJOH SPUBSZ QMBUF							

41]w' 1x±"íµí"Äpb{
5IF QBSUT XBOMZ BSF BWBJMBCMF BT TQBSF QBSUT





41		æ ¼ j ø / P		æ y ¼ y Ê y ¶	% FTDSJQUJPO	% FTUJOB	UJ J R O B O E B S E	QBSUT
	\$			- ÅX—	(VJEF QMBUF		B %	
	"			ÖçÄ!^Q	#FMU IPMEFS		C #	
	"			ÖçÄæ"Ó"æ ;	#FMU ESJWJOH QVMMFZ ;		E %	D #
	"			Ý»ç	.FUBM		F #	
	\$			#(ç—	/4 XJSJOH (G "	
	"			Ðiç £	1JO #		I %	H #
	\$			'FMX— \$³Ý	1BQFS SFHVMBUJOH QMBUF DPNCJOFE			
	"			¥Vpó³"A	1SFTTVSF TIFFU			
	"			N¥Ä-î±	1IPUP TFOTPS			
	\$			#(4Yb"»	/4 DPSSFUJPO NPUPS			
	"			\$¿Öæî-az ;	\$PVQMJOH HFBS ;			
	"			ÖçÄUçEaz ;	#FMU EFUFDUJOH HFBS ;			
	"			ÖçÄUçEÉ	#FMU EFUFDUJOH TDSFX			
	"			ÖçÄ -	1BQFS FYJU CFMU -			
	"			7"æP	4UJDLJOH QBSU			
	"			ÖçÄ— -	#FMU " -			
	"			ÖçÄ!^Q—	#FMU IPMEFS #			
	"			FMaz—(;	3FHVMBUJOH HFBS 4 ;			
	"			Äi³äiX\$³Ý	5FOTJPO QMBUF DPNCJOFE			
	"			-î±\$i"É	4FOTPS DPWFS BTTFNCMZ			
	"			N¥Ä-î±	1IPUP TFOTPS			
	"			- ÅX—	(VJEF QMBUF .JEEMF			
	\$			- - Å³"Ä	1BQFS FYJU HVJEF TIFFU			
	"			FMX— É	3FHVMBUJOH QMBUF 3FBS BTTFNCMZ			
	"			3"Óé¿«æÉ	3PDLJOH CMPDL BTTFNCMZ			
	"			FMX—²É	3FHVMBUJOH QMBUF 'SPOU BTTFNCMZ			
	"			ÖçÄ!^QX	#FMU IPMEFS QMBUF			

41]w' ¹x±"iü"Äpb{
5IF QBSUT XBOMZ BSF BWBJMBCMF BT TQBSF QBSUT





5C4/5C5

41	jø 3FG	/P æ ¼ j ø 1BSUT /P	æ y ¼ y Ê y ¶	%FTDSJQUJPO	%FTUJOB	UJROB a j æ ¼ OEBSÉ	QBSUT
		"	Ô ç Ä ! ^ Q —	#FMU IPMEFS #		B %	C #
		"	Ô ± " Ä Ö " æ — ;	&OUSBODF HVJEF QVMMFZ " ;			D \$
		"	V ù 4 • § á "	\$POWFZBODF BVYJMJB SZ DPMMBS			
		"	Ð ï ç £	1JO #		E #	
		\$	æ ^ é " ä	%SJWJOH SPMMFS		F "	G #
		"	Ô ± " Ä Ö " æ — ;	&OUSBODF HVJEF QVMMFZ # ;			
		"	- Ä Ö ç Ä	(VJEF CFMU		H #	
		"	Ý » ç	.FUBM		I %	
		\$	à ! " Ç ZX	4IBGU IPMEFS NPVOU QMBUF			J #
		"	Ô ç Ä — -	#FMU) -			
		\$	FM Ô ç Ä —	3FHVMBUJOH CFMU			
		\$	Ô ç Ä Ç ^ é	#FMU NPVOU SPMMFS			
		\$	FM Ô ç Ä —	3FHVMBUJOH CFMU			
		"	- \$	4OBQ SJOH			
		\$	ü " é " ä	0TDJMMBUF SPMMFS			
		\$	ü " Ö " æ — ;	0TDJMMBUF QVMMFZ ;			
		"	Ô ç Ä — -	#FMU + -			
		\$	ü " Ö " æ — ;	0TDJMMBUF QVMMFZ ;			
		"	Ô ç Ä —	#FMU &			
		\$	þ " » Ö " æ	.PUPS QVMMFZ			
		"	Ð ï ç £	1JO #			
		"	Ð ï	1JO			
		\$	() ' æ ^ þ " »	453 ESJWJOH NPUPS			
		"	æ ^ Ö " æ — ;	%SJWJOH QVMMFZ " ;			
		\$	# (ç —	1/4 XJSJOH *			
		"	V ù ! y à Ê	\$POWFZBODF QSFTTVSF TIBGU BTTFN CMZ			
		"	V ù ^ é	\$POWFZBODF SPMMFS			
		"	V ù ! y i Ê	\$POWFZBODF QSFTTVSF TQSJOH			
		"	† ? Ö ä ³	/FVUSBMJ [JOH CSVTI			
		\$	V ù " Ä X —	\$POWFZBODF HVJEF QMBUF "			
		\$	V ù " Ä X	\$POWFZBODF HVJEF QMBUF			
		\$	§ á " —	\$PMMBS \$			
		\$	V ù " Ä ³ " Ä —	\$POWFZBODF HVJEF TIFFU			

41 j w ' 1 x ± " i u i " Ä p b {
5IF QBSUT X B O M Z B S F B W B J M B C M F B T T Q B S F Q B S U T





41		æ ¼ j ø		æ y ¼ y Ê y ¶		% FTDSJQUJPO		5C4/5C5		
j ø	3FG	P	1BSUT	P				" 2 •	UJ # O B O E B S E	QBSUT
\$					\$" Å æ ç ' - " µ		\$BSUSJEHF DBTF		B #	
\$					µ Å Ö ç µ Å Å !		4UBQMF TMJEF TIBGU IPMEFS		D %	C "
"					µ Å Ö ç		4UBQMFT		E "	
"					ž Å ä " ä		*EMFS TIBGU		F \$	
\$					¥ V p o - é		1SFTTVSF SPMMFS		G \$	
"					é ç « Ö é ç «		-PDL CMPDL		H #	
\$					{ Ö é ç «		'JYFE CMPDL		I %	
\$					Ö ç Å — -		#FMU) -			
\$					é ç « i Ê		-PDL TQJSJOH			
\$					µ Å ç i i Ê		4UPQQFS TQJSJOH			
\$					µ Å ç i X — 2		4UPQQFS CPUUPN QMBUF 'SPOU			
\$					V ù " Å 3 " Å —		\$POWFZBODF HVJEF TIFFU			
\$					é ç « Ð I ç £		-PDL QJO %			
\$					¥ p o µ Å ç i — 2		1SFTTVSF TUPQQFS 'SPOU			
\$					µ Å ç i X —		4UPQQFS CPUUPN QMBUF 3FBS			
\$					¥ p o µ Å ç i —		1SFTTVSF TUPQQFS 3FBS			
\$					µ å Å 3 " Å —		4MJEF TIFFU			
\$					µ å Å 3 " Å —		4MJEF TIFFU			
\$					µ Å Ö ç S .		4UBQMF			
\$					¥ V p o æ P		'% ' QSFTTVSF QBSU			

41 j w ' 1 x ± " i µ i " Å p b {
5IF QBSUT X B O M Z B S F B W B J M B C M F B T T Q B S F Q B S U T



41		æ y ¼ y Ê y ¶		%FTDSJQUJPO	%FTUJOB	5C4/5C5		QBSUT
jø	3FG	P	æ ¼ j ø		" 2 •	a j æ ¼		
\$			µ á Á³"Á—	4MJEF TIFFU			B #	
"			{ Óé¿ «	'JYFE CMPDL			C "	
\$			ÓçÁ— -	#FMU) -			D %	
\$			é¿ « Óé¿ «	-PDL CMPDL			E "	
\$			µ Á Óçµ á Á à!	4UBQMF TMJEF TIBGU IPMEFS				F \$
\$			µ Á Óç" ÁX—²	4UBQMF HVJEF QMBUF 'SPOU				G #
\$			eFMX	8JSJOH SFHVMBUJOH QMBUF				H \$
\$			µ Á Óç§ì"	4UBQMF DPWFS			I #	
"			ž Á á"à	EMFS TIBGU			J #	
"			¥Vpo-é	1SF TTVSF SPMFMS				
\$			é¿ « Ðíø £	-PDL QJO %				
\$			é¿ « ÍÉ	-PDL TQSJOH				
\$			µ á Á³"Á—	4MJEF TIFFU				
\$			¥VpoæP	%' QSFTTVSF QBSU				
"			Ñ¥Á.ĩ±	1IPUP TFOTPS				
\$			µ Á Óç" ÁX—	4UBQMF HVJEF QMBUF 3FBS				
\$			µ Á Óç§.	4UBQMF				
\$			§"Áæ¿¿"-µ	\$BSUSJEHF DBTF				
			µ Á Óç	4UBQMFT				

41]w' ¹x±"íµí"Ápb{
5IF QBSUT XBOMZ BSF BWBJMBCMF BT TQBSF QBSUT



41		æ ¼ j ø		æ y ¼ y Ê y ¶		% FTDSJQUJPO		" 2 •		a j æ ¼		QBSUT	
3FG		P 1BSUT		P				%FTUJOB		UJROB		OEBS E QBSUT	
		"		ž Ā à " Ó " æ ;		*EMFS QVMMFZ ;				B %			
		"		Ō ç Ā ! ^ Q —		#FMU IPMEFS #				C #			
		\$		Ō ç Ā — -		#FMU) -				D #			
		\$		æ ^ à — Ê		%SJWJOH TIBGU " BTTFNCMZ						F #	
		\$... à ! Z		1BQFS GFFE TIBGU IPMEFS							
		"		μ Ā " Ō ç æ ^ a ž ;		4UBQMF ESJWJOH HFBS ;							
		\$		4 Y P " »		\$PSSFDUJPO NPUPS							
		\$		Ō ç Ā — -		#FMU * -							
		"		FM ^ ž — (;		3FHVMBUJOH HFBS 4 ;							
		\$		æ ^ à — Ê		%SJWJOH TIBGU # BTTFNCMZ							

41 j w ' 1 x ± " i μ i " Ā p b {
5IF QBSUT X B O M Z B S F B W B J M B C M F B T T Q B S F Q B S U T





1* ()

5C4/5C5



Đ 42 Đ

MJTU 41 L

42



0.3.3, 8:47 PM



41		P		P		%FTDSJQUJPO		%FTUJOB		5C4/5C5	
jØ		æ ¼ j Ø		æ y ¼ y Ê y ¶				a j æ ¼		QBSUT	
3FG		1BSUT						UJROB		EBS	
\$				#(4Yp"»		/4 DPSSFUDUJPO NPUPS					B %
"				¥Vpo³"Ä		1SFTTVSF TIFFU			C #		
"				N¥Ä.ĩ±		1IPUP TFOTPS			D #		
\$.ĩ±§i"		4FOTPS DPWFS			E %		F #
"				'FM X— §³Ý		1BQFS SFHVMBUJOH QMBUF DPNCJOFE					G #
"				3`Ó é j «æÊ		3PDLJOH CMPDL BTTFNCMZ			H #		
"				ÔçÄ!^QX		#FMU IPMEFS QMBUF					I \$
\$				'FMX—²		1BQFS SFHVMBUJOH QMBUF 'SPOU					J #
\$				'FMX—		1BQFS SFHVMBUJOH QMBUF 3FBS					
"				- ÄX		(VJEF QMBUF					
"				Äi³äiX§³Ý		5FOTJPO QMBUF DPNCJOFE					
"				z Ää"O"æ ;		*EMFS QVMMFZ ;					
"				ÔçÄ!^Q—		#FMU IPMEFS #					
"				ÔçÄ— -		#FMU " -					
\$				FMªz—(;		3FHVMBUJOH HFBS 4 ;					
\$				#(e—		/4 XJSJOH '					
\$				Vü" ÄX—		\$POWFZBODF HVJEF QMBUF					
\$				r†æP		3FMFBTF QBSU					
\$				r†iÉ—		3FMFBTF TQSSJOH					
\$				ÔçÄ!yiÉS³Ý		#FMU QSFTTVSF TQSSJOH DPNCJOFE					
\$				Vü" Ä³"Ä—		\$POWFZBODF HVJEF TIFFU #					
\$				Vü" ÄX—		\$POWFZBODF HVJEF QMBUF					

41 jw' 1x±"iui"Äpb{
5IF QBSUT XBOMZ BSF BWBJMBCMF BT TQBSF QBSUT



41		æ ¼ j ø		æ y ¼ y Ê y ¶		%FTDSJQUJPO		5C4/5C5		
j ø	3FG	P	1BSUT	P				" 2 •	UJ#O#OEBS	QBSUT
\$					àšÈšà"	41BGU TVQQPSU DPMMBS			B %	
\$					èl"3"À ;	-FWFS MPDLJOH HFBS ;				C &
\$					Vù" À³"À—	\$POWFZBODF HVJEF TIFFU "				D %
"					Ðīc £	1JO "			E %	
\$					µà ÁæP	4MJEF QBSU			F #	
"					{ Óé¿«	'JYFE CMPDL			G #	
\$					µÀ¿l,X	4UPQQFS CPBSE			H #	
\$					èl"3"šÜ	-FWFS MPDLJOH DBN			I #	
\$					µÀ¿lp"»	4UPQQFS NPUPS			J #	
\$					ÓçÀ—" -	#FMU . -				
\$					rtlÉ—	3FMFBTF TQSJOH				
"					ž Áà"Ó"æ ;	*EMFS QVMMFZ ;				
\$					µÀ¿liÉ—□	4UPQQFS TQSJOH .JEEMF				
\$					rtµÀ¿í	3FMFBTF TUPQQFS				
\$					µÀ¿l³"À	4UPQQFS TIFFU				
"					ÓçÀ!^Q—	#FMU IPMEFS #				
\$					N#Á.ĩ±	11PUP TFOTPS				
\$					#(e—	1/4 XJSJOH (
\$...`à!Z	1BQFS GFFE TIBGU IPMEFS				
\$					4Yb"»	\$PSSFDUJPO NPUPS				
\$					µÀ Óçµà Áaz— ;	4UBQMF TMJEF HFBS # ;				
\$					rtèl"	3FMFBTF MFWFS				
\$					µÀ Óçµà ÁÓ"æ ;	4UBQMF TMJEF QVMMFZ ;				
"					µÀ"Óçæ^az ;	4UBQMF ESJWJOH HFBS ;				
"					N#Á.ĩ±	11PUP TFOTPS				

41]w' 1x±"iµi"Àpb{
5IF QBSUT XBOMZ BSF BWBJMBCMF BT TQBSF QBSUT



41		P		æ y ¼ y Ê y ¶		%FTDSJQUJPO		%FTUJOB		5C4/5C5	
j ø / 3FG		æ ¼ j ø / P		æ y ¼ y Ê y ¶		%FTDSJQUJPO		%FTUJOB		QBSUT	
	\$			ÐT§i"—		"EKVTUJOH DPWFS				B %	
	\$			-- AX—<		1BQFS FYJU HVJEF QMBUF -PXFS					C #
	"			µÄ¿l°Ü		4UPQQFS SVCCFS				D #	
	\$!yé"á		1SFTTVSF SPMMFS				E #	
	\$,"é"á—í		1PME EPXO SPMMFS 6QQFS					F #
	\$,"é"á—<		1PME EPXO SPMMFS -PXFS					G %
	\$			FM°Ü		13FHVMBUJOH SVCCFS				H "	
	\$			ž « ½ £ »—		"DUVBUPS					
	\$			-- AX—í		1BQFS FYJU HVJEF QMBUF 6QQFS					
	\$			·i± ÇµÄ"		4FOTPS NPVOU TUBZ					
	\$!yž"Ü— ²		1SFTTVSF BSN 'SPOU					
	\$!y!É		1SFTTVSF TQJSJOH					
	\$!yž"Ü—		1SFTTVSF BSN 3FBS					
	\$,"ž"Ü—í		1PME EPXO BSN 6QQFS					
	\$,"!É—<		1BQFS IPME EPXO TQJSJOH -PXFS					
	\$,"ž"Ü—<		1PME EPXO CMBEF -PXFS					
	\$,"!É—í		1BQFS IPME EPXO TQJSJOH 6QQFS					
	\$			§ÜÑ#éžµä Äĩµ		§BN GPMMPXFS TMJEF TDSFX					
	\$			·ßÜr†ÉÖ		+BN SFMFBTF LOPC					
	\$			Ñ#Ä·i±		1IPUP TFOTPS					
	\$			·i± "ÇZX—		4FOTPS NPVOU QMBUF #					
	\$			#(ç—		1/4 XJSJOH					
	\$			·i±!y!É—		4FOTPS QSFTTVSF TQJSJOH					
	\$			Ø"çÖžæĩ-ç £		#BMM CFBSJOH #					
	\$			ž « ½ £ »—		"DUVBUPS					

41]w' 1x±"iµi"Äp{
5IF QBSUT XBOMZ BSF BWBJMBCMF BT TQBSF QBSUT



41		P		æy¼yËy¶		%FTDSJQUJPO		" 2 •		5C4/5C5	
jØ / 3FG		æ ¼ j Ø / P		æy¼yËy¶		%FTDSJQUJPO		%FTUJOB		a j æ ¼ QBSUT	
"		"		Ú-É¿Ä@B¿½		.BHOFU DBUDI		B %			C %
\$		\$		Vù\$X-²		\$POWFZBODF GVMDSVN QMBUF 'SPOU		D #			
\$		\$		- Á³"Á-		(VJEF TIFFU "		E "			
"		"		- ÁX-		(VJEF QMBUF #		F #			
"		"		r†èì"m‡^		3FMFBTF MFWFS LOPC		#			G
"		"		Ö"í"!í[èì"à!ç £	1BQFS	MJGU VQ MFWFS TIBGU IPMEFS #		H "			
"		"		N*Ä.ĩ±		1IPUP TFOTPS					
\$		\$		Ðĩ		1JO "					
"		"		Ëj[µÄ"		-JGU VQ TUBZ					
\$		\$		ÖçÄH"é"á		#FMU ESJWFO SPMFMS					
"		"		Vúé"á-		\$POWFZBODF SPMFMS #					
"		"		VùÖçÄ -		\$POWFZBODF CFMU -					
"		"		Vúé"á-		\$POWFZBODF SPMFMS "					
"		"		Ý»ç		.FUBM					
"		"		ž"µíÉ		&BSUI TQSOJH					
"		"		ž«½£"»-		"DUVBUPS					
"		"		·ĩ±{ X		4FOTPS GJYFE QMBUF					

41]w' ¹x±"ĩµí"Äpb{
5IF QBSUT XßOMZ BSF BWBJMBCMF BT TQBSF QBSUT



1* ()

5C4/5C5



Ø 50 Ø

MJTU 41 L

50

0.3.3, 8:47 PM





41		P		æy¼yËy¶		%FTDSJQUJPO		5C4/5C5		QBSUT	
3FG	1BSUT										
	\$		4Yp"»		\$PSSFDUJPO NPUPS				B #		
	\$		#(c—		/4 XJSJOH				C %		
	"		N¥Á·i±		1IPUP TFOTPS				D %		
	"		·i±!yiË		4FOTPS QSFTTVSF TQJSJOH					E #	
	"		FMªž—(;		3FHVMBUJOH HFBS 4 ;					F #	
	"		µÁ"Óçæªž ;		4UBQMF ESJWJOH HFBS ;					G #	
	"		N¥Á·i±		1IPUP TFOTPS				H %		
	"		ž Áª"Ó"æ ;		*EMFS QVMMFZ ;				I #		
	\$		ÓçÁ— -		#FMU + -				K #		
	"		ÓçÁ!^Q—		#FMU IPMEFS #				L "		
	\$		µÁží X		1BQFS TUPQQFS CPUUPN QMBUF				O "		N "
	\$		· ÁX—		(VJEF QMBUF "						
	\$		µá ÁæP		4MJEF QBSU						
	\$		µÁží		1BQFS TUPQQFS						
	\$		µÁží!^Q		1BQFS TUPQQFS IPMEFS						
	"		{ Óéž«		'JYFE CMPDL						
	\$		· Áª"Á—		(VJEF TIFFU #						
	"		·i±{ X		4FOTPS GJYFE QMBUF						
	"		ž « ½£" —		"DUVBUPS						

41]w' 'x±"iµi"Ápb{
5IF QBSUT XBOMZ BSF BWBJMBCMF BT TQBSF QBSUT



1* ()

5C4/5C5



Đ 52 Đ

MJTU 41 L

52



0.3.3, 8:47 PM



41		P		æy¼yËy¶		%FTDSJQUJPO		" 2 •		a j æ ¼		5C4/5C5	
3FG		1BSUT						%FTUJOB		UJROB		QBSUT	
\$	#(P"»					/4 NPUPS						B #	
\$	- Àà!—					VJEF TIBGU IPMEFS "						C %	
"	N¥Á·ī±					1IPUP TFOTPS						D #	
\$	"Òè"Á					PME EPXO CMBEF						E %	
\$	Òè"Áæ"§Ü ;					#MBEF ESJWJOH DBN ;							F %
\$	Òè"Áž Áá"áz ;					#MBEF JEMFS HFBS ;							G #
\$	§ÜN¥éžà!					\$BN GPMMPXFS TIBGU IPMEFS							H #
\$	- Àà!—					VJEF TIBGU IPMEFS #						I \$	
\$	#(P' c—					/4 SFMBZ XJSJOH						K #	
\$	çñç¥"Ü					6Q EPXO XPSN						L #	
												N "	
												O "	
												Q \$	

41]w' 1x±"iui"Àpb{
5IF QBSUT XBOMZ BSF BWBJMBCMF BT TQBSF QBSUT



41		P		æ y ¼ y È y ¶		% FTDSJQUJPO		% FTUJOB		5C4/5C5	
j ø / 3FG		æ ¼ j ø / P		æ y ¼ y È y ¶		% FTDSJQUJPO		% FTUJOB		a j æ ¼ QBSUT	
		"	\$	§ á" —		\$PMMBS "				B %	
		"	\$	Ó ç Ä —		#FMU , -				C %	
		"	\$	V ù Ó" æ — ;		\$POWFZBODF QVMMFZ \$;				E #	D #
		"	\$	Ð ï ç £		1JO #				F #	
		"	\$	FM ° Û		3FHVMBUJOH SVCCFS					
		"	\$	V ù Ó" æ — ;		\$POWFZBODF QVMMFZ # ;					
		"	\$	Ð ï		1JO "					
		"	\$	Ó ç Ä ! ^ Q —		#FMU IPMEFS #					
		"	\$	V ù Ó" æ — ;		\$POWFZBODF QVMMFZ % ;					
		"	\$	o 8 Ó" æ ;		3FWFSTBM QVMMFZ ;					
		"	\$	V ù Ó" æ — ;		\$POWFZBODF QVMMFZ " ;					
		"	\$	o 8 Ó ç Ä -		3FWFSTBM CFMU -					
		"	\$	æ ^ Ó ç Ä —		%SJWJOH CFMU " -					
		"	\$	æ ^ Ó ç Ä —		%SJWJOH CFMU % -					
		"	\$	à ! —		4IBGU IPMEFS					
		"	\$	ž Ä á" Ó" æ — ;		*EMFS QVMMFZ " ;					
		"	\$	8U " à !		4MJEF TIBGU IPMEFS					
		"	\$	æ ^ Ó ç Ä —		%SJWJOH CFMU # -					
		"	\$	ž Ä á" § á" —		*EMFS DPMMBS					
		"	\$	ž Ä á" Ó" æ — ;		*EMFS QVMMFZ # ;					
		"	\$	l É		4QSOH					
		"	\$	æ ^ Ó" æ ;		%SJWJOH QVMMFZ ;					
		"	\$... " b" »		1BQFS GFFE NPUPS					
		"	\$! y " a ž ;		1SFTTVSF HFBS ;					
		"	\$	Ð ï		1JO \$					
		"	\$! y ž Ä á" — ;		1SFTTVSF JEMFS # ;					
		"	\$... " à ! Z		1BQFS GFFE TIBGU IPMEFS					
		"	\$! y ž Ä á" — ;		1SFTTVSF JEMFS " ;					
		"	\$! y Ó" æ ;		1SFTTVSF QVMMFZ ;					
		"	\$... " Ó" æ ;		1BQFS GPME EPXO QVMMFZ ;					
		"	\$	Ó ç Ä ! ^ QX —		#FMU IPMEFS QMBUF "					
		"	\$	æ ^ Ó ç Ä —		%SJWJOH CFMU \$ -					

41 j w' ' x ± " i u i " A p b {
5IF QBSUT X B O M Z B S F B W B J M B C M F B T T Q B S F Q B S S T



5C4/5C5

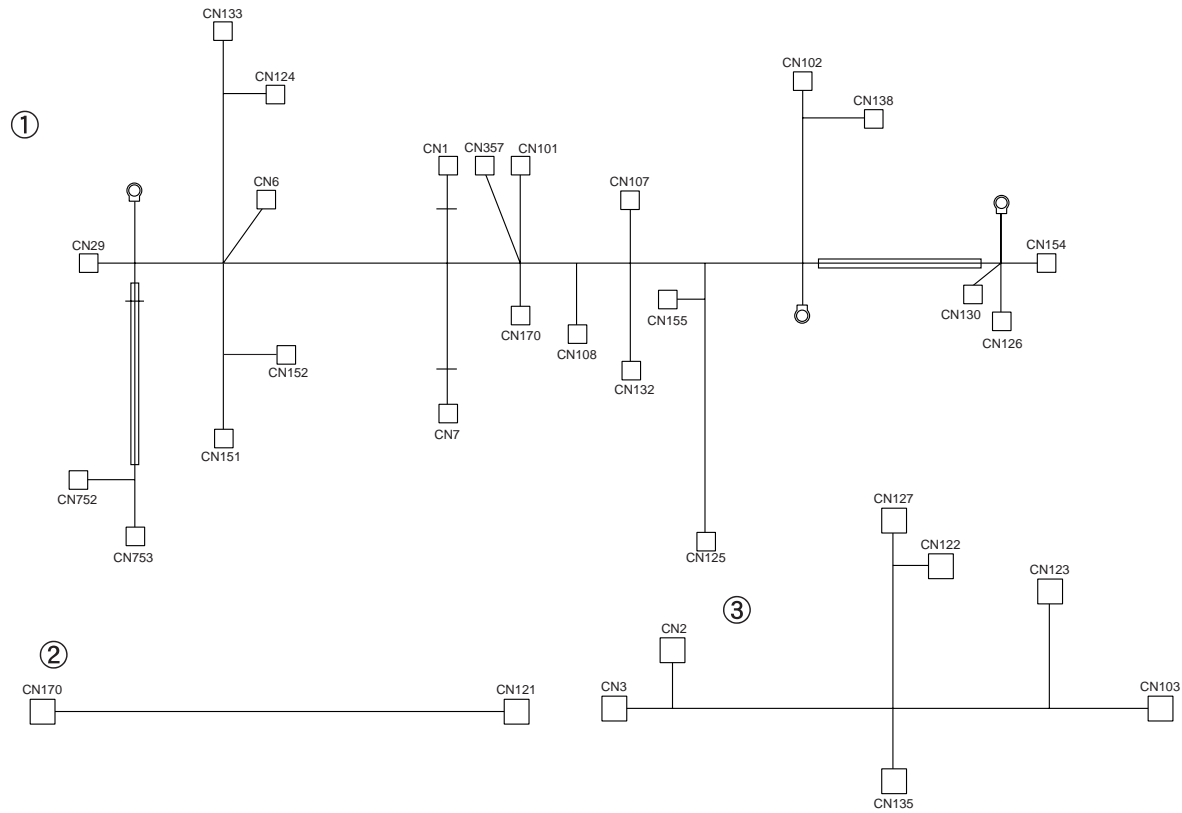

Đ 56 Đ



5C4/5C5

41	jø 3FG	P æ ¼ j ø 1BSUT /P	æ y ¼ y Ê y ¶	%FTDSJQUJPO	" 2 • %FTUJOB	UJ R O B O E B S E QBSUT
		\$ \$ \$	# (e — # (e — # (e —	/4 XJSJOH " /4 XJSJOH # /4 XJSJOH \$		

41 jw' 1x±"iui"Àpb{
5IF QBSUT XOMZ BSF BWBJMBCMF BT TQBSF QBSUT





5C4/5C5

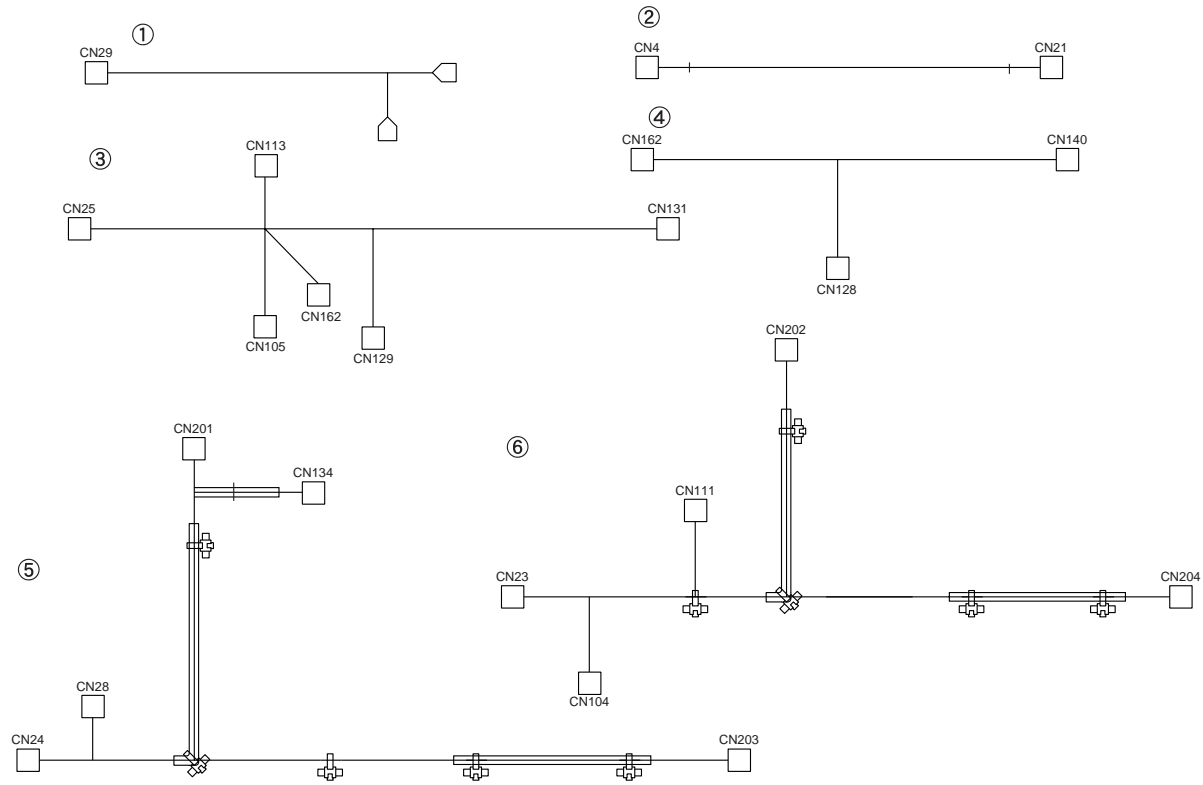

Đ 58 Đ





5C4/5C5

41	jø 3FG	æ ¼ j ø P 1BSUT /P	æ y ¼ y Ê y ¶	%FTDSJQUJPO	" 2 • %FTUJOB	UJ#O#OEBSÊ QBSUT
		\$ \$ \$ \$ \$ \$	# (e— # (e— # (e— # (e— # (e— # (e—	/4 XJSJOH % /4 XJSJOH & /4 XJSJOH ' /4 XJSJOH (/4 XJSJOH) /4 XJSJOH *		

41 jw' 1x±"iui"Àpb{
5IF QBSUT X#OMZ BSF BWBJMBCMF BT TQBSF QBSUT





5C4/5C5

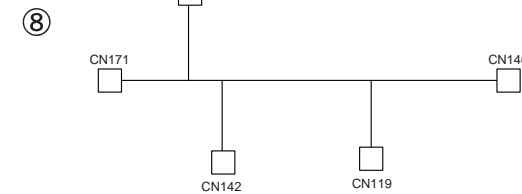
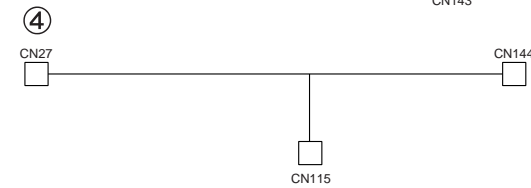
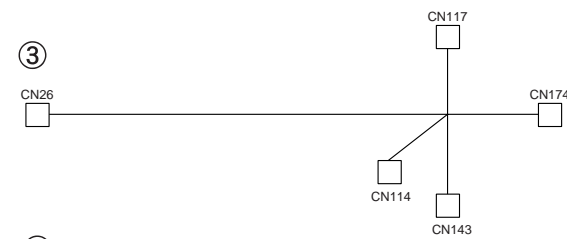
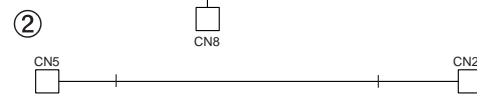
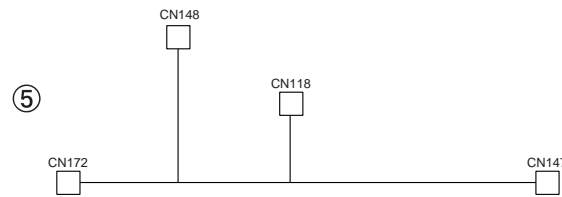
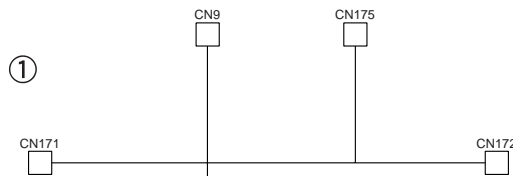

Đ 60 Đ





5C4/5C5

41	jø 3FG	æ ¼ j ø 1BSUT /P	æ y ¼ y Ê y ¶	%FTDSJQUJPO	" 2 • %FTUJOB	a j æ ¼ UJROBEOEBSE	QBSUT
		\$	# (c —	/4 XJSJOH			
		\$	# (c —	/4 XJSJOH			
		\$	# (c —	/4 XJSJOH			
		\$	# (c —	/4 XJSJOH			
		\$	# (c —	/4 XJSJOH			
		\$	# (c —	/4 XJSJOH			
		\$	# (c —	/4 XJSJOH			
		\$	# (□' c —	/4 SFMBZ XJSJOH			

41 j w' 1 x ± " i u i " Å p b {
5IF QBSUT X BOMZ BSF B W B J M B C M F B T T Q B S F Q B S U T





INDEX

SP	部品番号 Parts No.	部 品 名 称	Description	Fig. No.
●	36882040	ステイプル針	Staples	18,19
●	5A807760	フォトセンサ	Photo sensor	4,5,6,9, 16,24,25
	5A808170	外装補助パネル	External auxiliary panel	3
	5A808530	マグネット受板	Magnet catch	3
	5A808710	ネジカバー	Screw cover	3
●	5A811120	ピン (B)	Pin(B)	4,17,27
●	5A811470	メタル	Metal	4,5,6,7, 9,10,11, 12,13,16, 17,24
	5A811870	ピン	Pin	17
	5A813710	マグネットキャッチ	Magnet catch	3,6,24
●	5A813790	ピン (A)	Pin(A)	11
●	5A814320	止め輪	Snap ring	17
●	5A815900	ピン B	Pin B	6,9,16, 17
●	5A815930	センサ押圧バネ	Sensor pressure spring	25
	5A815950	センサ固定板	Sensor fixed plate	24,25
	5A815960	アクチュエータ / 1	Actuator/1	24,25
	5A816120	アースバネ	Earth spring	24
	5A816830	段付きネジ	Shoulder screw	4
●	5A818490	ペーパー押し上げレバー軸受 (B)	Paper lift-up lever shaft holder(B)	4,5,6,8, 9,10,24
	5A818950	排紙従動コロ / B	Paper exit driven roller/B	3
	5A819510	ストップゴム	Stopper rubber	4,5,6,23
	5A821490	歯車 (E)	Gear(E)	11
●	5A822060	マグネットキャッチ	Magnet catch	1,2
	5A822120	把手	Knob	14,15
	5A823820	貼り部材	Sticking part	9,10,12, 13,16
●	5A824360	転がり軸受	Slide shaft holder	27
	5A824740	ピン (A)	Pin(A)	4,22
	5A825890	マグネットキャッチ	Magnet catch	5
	5A907130	スライドステー / A	Slide stay/A	3
	5A907140	排紙ストッパ	Paper exit stopper	1,2
	5A907150	センサカバー	Sensor cover	3
	5A907210	補強ステー	Reinforcing stay	1,2
●	5A907270	架台ローラ / R	Carriage roller/R	1,2

SP欄の ● 印はサービスパーツです。
The parts with "●" only are available as spare parts.

5C4/5C5

SP	部品番号 Parts No.	部 品 名 称	Description	Fig. No.
●	5A907320	フォトセンサ	Photo sensor	1,2,3,8, 11,14,16, 19,21,22, 25,26
	5A907330	従動軸受	Driven shaft holder	3
	5A907340	支持板 / A	Support plate/A	3
	5A907620	軸 / 下	Shaft/Lower	3
	5A907640	規制軸	Regulating shaft	1,2
	5A907720	アクチュエータ	Actuator	3
	5A907750	背面取付板	Rear side mount plate	3
	5A907900	シフトモーター組	Shift motor assembly	8,11
	5A907910	モータ取り付け板	Motor mount plate	8
	5A907940	スライドステー / A カシメ	Slide stay/A combined	8
	5A907990	スライドアーム	Slide arm	8,9
●	5A908040	突き当てコロ	Pressure roller	8,18,19
	5A908080	軸受 / A	Shaft holder/A	8
	5A908120	突き当てシート	Pressure sheet	8,16,21
	5A908160	入り口コロ	Entrance roller	4,5,8
	5A908190	駆動プーリ / A (Z=24)	Driving pulley/A (Z=24)	4,10,12, 13,17
	5A908200	ソレノイドレバー	Solenoid lever	12,13
	5A908220	F N S ソレノイド組	FNS solenoid assembly	12,13
●	5A908430	搬送押圧バネ	Conveyance pressure spring	6,8,17
	5A908450	解除レバーつまみ	Release lever knob	5,6,24
	5A908460	持ち上げステー	Lift-up stay	5,6,24
	5A908490	搬送押圧軸 / B 組	Conveyance pressure shaft/B assembly	4,5
	5A908560	検知センサー / 2	Detecting sensor/2	5,6
	5A908590	ソレノイドバネ	Solenoid spring	5
	5A908830	ヒンジバネ / A	Hinge spring/A	6
	5A908840	ヒンジバネ / B	Hinge spring/B	6
	5A908900	搬送押圧軸組	Conveyance pressure shaft assembly	6,8,17
●	5A908950	搬送ローラ / C	Conveyance roller/C	6
	5A908960	案内軸 / A	Guide shaft/A	6
	5A908970	ソレノイドバネ	Solenoid spring	6
	5A908980	案内軸 / B	Guide shaft/B	6
	5A909060	搬送コロ	Conveyance roller	6,17
	5A909160	ソレノイド組	Solenoid assembly	9
	5A909170	ソレノイド取り付け板	Solenoid mount plate	9
	5A909180	ソレノイドバネ	Solenoid spring	9
	5A909190	ソレノイドレバー	Solenoid lever	9



5C4/5C5

SP	部品番号 Parts No.	部 品 名 称	Description	Fig. No.	SP	部品番号 Parts No.	部 品 名 称	Description	Fig. No.
	5A909250	排紙搬送軸	Paper exit conveyance shaft	9		5A910530	テンションコロ	Tension roller	11
	5A909260	排紙支持軸	Paper exit support shaft	9		5A910670	ガイド板 / 中	Guide plate/Middle	16
	5A909270	排紙コロ	Paper exit roller	9	●	5A910720	ベルト検知ギア (Z=102)	Belt detecting gear (Z=102)	16
●	5A909280	回転ストップバ	Rotary stopper	9		5A910730	ベルト検知ネジ	Belt detecting screw	16
	5A909300	軸受	Shaft holder	9		5A910750	揺動ブロック部組	Rocking block assembly	16,21
	5A909310	排紙押圧バネ	Paper exit pressure spring	9		5A910760	ベルト押さえ板	Belt holder plate	16,21
	5A909320	排紙ガイドステー	Paper exit guide stay	9		5A910790	ベルト押さえ	Belt holder	16
●	5A909330	除電ブラシ	Neutralizing brush	1,2,3,7, 9,17	●	5A910800	排紙ベルト (L=518)	Paper exit belt (L=518)	16
	5A909340	排紙ガイド板 / 上	Paper exit guide plate/Upper	9		5A910810	ベルト駆動プーリ (Z=18)	Belt driving pulley (Z=18)	16
	5A909350	排紙ガイドシート	Paper exit guide sheer	9		5A910820	規制ギア / S (Z=55/28)	Regulating gear/S (Z=55/28)	16,20
	5A909360	排紙ガイド板 / 中	Paper exit guide plate/Middle	9	●	5A910820	規制ギア / S (Z=55/28)	Regulating gear/S (Z=55/28)	21,25
	5A909370	ストップバ	Stopper	9		5A910830	ベルト / A (L=752)	Belt/A (L=752)	16,21
	5A909390	センサカバー組	Sensor cover assembly	9,16		5A910840	ベルト押さえ / B	Belt holder/B	16,20,21, 22,25,27
●	5A909420	排紙ローラー / A	Paper exit roller/A	6,10		5A910860	テンション板カシメ	Tension plate combined	16,20,21, 22,25
	5A909440	回転板カシメ組	Rotary disk assembly	10		5A911040	ベルト押さえ / B	Belt holder/B	17
	5A909460	排紙プーリ / A (Z=26)	Paper exit pulley/A (Z=26)	10		5A911050	入口ガイドプーリ / A (Z=34)	Entrance guide pulley/A (Z=34)	17
	5A909480	モータープーリ (Z=16)	Motor pulley (Z=16)	10,11		5A911080	入口ガイドプーリ / B (Z=31)	Entrance guide pulley/B (Z=31)	17
●	5A909490	ベルト / B (L=192)	Belt/B (L=192)	10	●	5A911090	ガイドベルト	Guide belt	17
	5A909510	軸受 (A)	Shaft holder(A)	10,11,12, 13	●	5A911100	ベルト / H (L=116)	Belt/H (L=116)	17
●	5A909540	ベルト / E (L=180)	Belt/E (L=180)	11,17	●	5A911180	ベルト / J (L=159)	Belt/J (L=159)	17
	5A909560	排紙プーリ / B (Z=40/52/26)	Paper exit pulley/B (Z=40/52/26)	10	●	5A911220	搬送補助カラー	Conveyance auxiliary collar	6,17
	5A909570	カラ / A	Collar/A	10,11,27	●	5A911500	ステーブル駆動ギア (Z=51/21)	Staple driving gear (Z=51/21)	20,22,25
●	5A909580	排紙バネ	Paper exit spring	10		5A911690	固定ブロック	Fixed block	18,19,22, 25
	5A909610	排紙ガイド板 / 中組	Paper guide plate/Middle assembly	9		5A911800	アイドラー軸	Idler shaft	18,19
	5A909620	排紙ガイドステー / B	Paper exit guide stay/B	9		5A912680	搬送ガイド板 / A	Conveyance guide plate/A	17
	5A909760	スライド軸	Slide shaft	7		5BA08000	アクチュエーター	Actuator	3
	5A909770	コロ	Roller	7	●	5C319220	ボールベアリング (B)	Ball bearing(B)	4,23
	5A909910	テンションプーリ	Tension pulley	7	●	5C319250	フォトセンサ	Photo sensor	22,23
	5A909920	テンション板カシメ	Tension plate combined	7	●	5C330850	給紙軸受け	Paper feed shaft holder	20,22,27
	5A909970	昇降ギア / A (Z=44/21)	Up-down gear/A (Z=44/21)	7		5C330980	駆動すべり軸受 (A)	Driving slide shaft holder(A)	7
	5A909980	昇降ギア / B (Z=52/15)	Up-down gear/B (Z=52/15)	7	●	5C331000	ピン A	Pin A	24,27
	5A910000	昇降プーリ	Up-down pulley	7	●	5C400010	天板	TOP BOARD	3
	5A910020	昇降ギア / C (Z=30)	Up-down gear/C (Z=30)	7	●	5C400020	カバー、前 A	FRONT COVER A	3
	5A910030	ピン C	Pin C	7,27	●	5C400040	カバー、横前	FRONT COVER,SIDE	3
	5A910240	ベルトテンションバネ	Belt tension spring	12,13	●	5C400050	カバー、後	REAR COVER	3
●	5A910260	駆動プーリ / C (Z=30/24)	Driving pulley/C (Z=30/24)	12,13	●	5C400060	シール	SEAL	3
	5A910360	排紙ギヤ (Z=100/20)	Paper exit gear (Z=100/20)	11	●	5C400070	カバー、排紙	COVER,PAPER EJECT	3
	5A910380	駆動プーリ / D	Driving pulley/D	11					

SP欄の ● 印はサービスパーツです。
The parts with "●" only are available as spare parts.

- 63 -



5C4/5C5

SP	部品番号 Parts No.	部 品 名 称	Description	Fig. No.
●	5C400080	トレイ、排紙昇降 1	TRAY 1,PAPER EJECT LIFT	7
●	5C400090	トレイ、排紙昇降 2	TRAY 2,PAPER EJECT LIFT	7
●	5C400100	トレイ、排紙 1	TRAY 1,PAPER EJECT	3
●	5C400110	トレイ、排紙 2	TRAY 2,PAPER EJECT	3
	5C410010	ガイド板 / 下	Guide plate/Lower	8
	5C410020	案内板	Guide plate	8
●	5C410030	排紙駆動軸	Paper exit driving shaft	10
	5C410040	排紙ガイド板	Paper exit guide plate	10
	5C410050	排紙補強ステー	Paper exit reinforcing stay	7
	5C410060	モータプーリ	Motor pulley	17
●	5C410070	スライドギア / B (Z=100)	Slide gear/B (Z=100)	8
	5C410100	排紙昇降アクチュエータ	Paper exit up-down actuator	3
	5C410110	束線ガイドアーム	Wiring guide arm	1,2
●	5C410120	昇降ワイヤ / R	Up-down wire/R	7
●	5C410130	昇降ワイヤ / F	Up-down wire/F	7
	5C410140	ロックバネ	Lock spring	1,2
	5C410150	スライドレール / 右	Slide rail/Right	1,2
	5C410160	スライドレール / 左	Slide rail/Left	1,2
	5C410170	架台ローラ / 1	Carriage roller/1	1,2
	5C410180	アクチュエータ / 1	Actuator/1	1,2
	5C410190	防止部材 / 1	Preventive part/1	3
	5C410210	モータ組	Motor assembly	7
	5C410220	把手	Knob	3
	5C410260	ヒンジ板 / 上	Hinge plate/Upper	3
	5C410270	ヒンジ板 / 下	Hinge plate/Lower	3
	5C410280	パネル / 前	Panel/Front	14,15
	5C410290	パネル / 奥	Panel/Rear	14,15
	5C410300	軸支持板 / B	Shaft support plate/B	14,15
	5C410310	軸支持板 / C	Shaft support plate/C	14
	5C410320	ステイブルスライド軸受	Staple slide shaft holder	18,19
	5C410330	束線回転板 / 2	Wiring rotary plate/2	14,15
	5C410340	ステイブルガイド板 / 前	Staple guide plate/Front	19
	5C410350	ステイブルガイド板 / 奥	Staple guide plate/Rear	19
	5C410360	突当てストップパ / 前	Pressure stopper/Front	18
	5C410370	ストップバネ	Stopper spring	18
	5C410380	突当てストップパ / 奥	Pressure stopper/Rear	18
	5C410390	カートリッジ案内レール	Cartridge guide seal	14,15
	5C410400	ロックブロック	Lock block	18,19
	5C410410	ロックバネ	Lock spring	18,19
	5C410420	ロックピン (8)	Lock pin(D8)	18,19

SP欄の ● 印はサービスパーツです。
The parts with "●" only are available as spare parts.

SP	部品番号 Parts No.	部 品 名 称	Description	Fig. No.
	5C410430	ベルト固定ブロック	Belt fixed block	14,15
	5C410440	ステイブル回転コロ	Staple rotary roller	14,15
	5C410450	ガイド板 / 1	Guide plate/1	16
	5C410460	搬送ガイド板	Conveyance guide plate	17
	5C410470	軸受取り付け板	Shaft holder mount plate	17
●	5C410480	ステイブル本体	Staple	18,19
●	5C410490	首振りローラ	Oscillate roller	17
	5C410500	束線規制板	Wiring regulating plate	19
	5C410510	排紙ガイドシート	Paper exit guide sheet	16
	5C410520	ストップ底板 / 前	Stopper bottom plate/Front	18
	5C410530	ストップ底板 / 奥	Stopper bottom plate/Rear	18
●	5C410540	駆動ローラ	Driving roller	17
	5C410550	首振りプーリ / 2 (Z=20)	Oscillate pulley/2 (Z=20)	17
	5C410560	首振りプーリ / 1 (Z=20)	Oscillate pulley/1 (Z=20)	17
	5C410570	ベルト取付コロ	Belt mount roller	17
●	5C410580	規制ベルト / 1	Regulating belt/1	17
●	5C410590	規制ベルト / 2	Regulating belt/2	17
	5C410600	架台カバー / 上	Carriage cover/Upper	14,15
	5C410610	ステイブルカバー	Staple cover	19
	5C410620	架台カバー / 左	Carriage cover/Left	14,15
	5C410630	規制パッド	Regulating pad	14
	5C410640	搬送ガイドシート / 1	Conveyance guide sheet/1	18
	5C410650	スライドシート / 1	Slide sheet/1	18,19
	5C410660	スライドシート / 2	Slide sheet/2	18,19
	5C410670	カバー / 右	Cover/Right	14
	5C410680	搬送ガイドシート / 2	Conveyance guide sheet/2	17
	5C410690	規制板 / 前組	Regulating plate/Front assembly	16
	5C410700	規制板 / 奥組	Regulating plate/Rear assembly	16
	5C410710	搬送ガイド板 / A	Conveyance guide plate/A	5
	5C410720	搬送ガイド板 / B	Conveyance guide plate/B	5
	5C410730	搬送ガイド板 / C	Conveyance guide plate/C	6
	5C410740	搬送ガイド板 / D	Conveyance guide plate/D	6
	5C410750	搬送ガイド板 / E	Conveyance guide plate/E	6
	5C410760	搬送ガイド板 / F	Conveyance guide plate/F	6
●	5C410770	搬送ローラ / A	Conveyance roller/A	5
●	5C410780	搬送ローラ / B	Conveyance roller/B	5
	5C410790	搬送押圧バネ	Conveyance pressure spring	4,5
	5C410800	支持板	Support plate	5
	5C410810	紙案内部材	Paper guide part	5
	5C410820	突き当てゴム	Pressure rubber	6



5C4/5C5

SP	部品番号 Parts No.	部 品 名 称	Description	Fig. No.	SP	部品番号 Parts No.	部 品 名 称	Description	Fig. No.
●	5C410830	搬送スライド軸	Conveyance slide shaft	8	●	5C411230	ベルト / D (L=228)	Belt/D (L=228)	12,13
	5C410840	プーリ押え部材	Pulley holding part	11	●	5C411240	ベルト / C (L=207)	Belt/C (L=207)	12,13
	5C410850	ヒンジバネ / C	Hinge spring/C	5	●	5C411250	ベルト / E (L=222)	Belt/E (L=222)	4
	5C410860	ヒンジバネ / D	Hinge spring/D	5	●	5C411260	ベルト / F (L=315)	Belt/F (L=315)	10
●	5C410870	搬送ローラ / C	Conveyance roller/C	5	●	5C411270	ベルト / H (L=976)	Belt/H (L=976)	18,19,20
	5C410880	排紙側板 / 前	Paper exit side plate/Front	1,2	●	5C411280	ベルト / I (L=660)	Belt/I (L=660)	20
	5C410890	排紙側板 / 奥	Paper exit side plate/Rear	1,2	●	5C411290	排紙駆動ベルト / A (L=204)	Paper exit driving belt/A (L=204)	4
	5C410900	排紙ガイド板 / A	Paper exit guide plate/A	4	●	5C411300	排紙駆動ベルト / B (L=267)	Paper exit driving belt/B (L=267)	11,12
	5C410910	排紙ガイド板 / B	Paper exit guide plate/B	4	●	5C411300	排紙駆動ベルト / B (L=267)	Paper exit driving belt/B (L=267)	13
	5C410920	排紙ガイド板 / C	Paper exit guide plate/C	4	●	5C411310	搬送モータ	Conveyance motor	11
●	5C410930	排紙ローラ / A	Paper exit roller/A	4	●	5C411320	F N S 補正モータ	FNS correction motor	16,21
●	5C410940	排紙ローラ / B	Paper exit roller/B	4	●	5C411330	補正モータ	Correction motor	20,22,25
●	5C410950	搬送駆動ローラ / A	Conveyance driving roller/A	4		5C411340	F N S 束線 / A	FNS wiring/A	28
	5C410960	バネ / 下	Spring/Lower	3		5C411350	F N S 束線 / B	FNS wiring/B	4,28
	5C410970	除電板	Neutralizing plate	3		5C411360	F N S 束線 / C	FNS wiring/C	28
	5C410980	アース板	Earth plate	3		5C411370	F N S 束線 / D	FNS wiring/D	3,29
	5C410990	開閉レバー / 1	Open-close lever/1	4		5C411380	F N S 束線 / E	FNS wiring/E	29
	5C411000	開閉レバー / 2	Open-close lever/2	4		5C411390	F N S 束線 / F	FNS wiring/F	21,29
	5C411010	搬送ガイド板 / 1	Conveyance guide plate/1	4		5C411400	F N S 束線 / G	FNS wiring/G	16,22,29
	5C411020	搬送ガイド板 / 2	Conveyance guide plate/2	4		5C411410	F N S 束線 / H	FNS wiring/H	29
	5C411030	搬送ガイド板 / 3	Conveyance guide plate/3	4		5C411420	F N S 束線 / I	FNS wiring/I	17,29
	5C411040	搬送押圧バネ	Conveyance pressure spring	4	●	5C411430	制御部	Control unit	1
	5C411060	排紙センサー組	Paper exit sensor assembly	16		5C411440	中継基板部組	Relay board assembly	14,15
	5C411070	紙規制板 / 1 カシメ	Paper regulating plate/1 combined	4	●	5C411450	R O M 組	ROM assembly	1
	5C411080	駆動軸 / A 組	Driving shaft/A assembly	20		5C411460	注意ラベル / A	Caution label/A	3
	5C411090	駆動軸 / B 組	Driving shaft/B assembly	20		5C411470	カートリッジケース	Cartridge case	18,19
	5C411100	テンション軸受	Tension shaft holder	4		5C411480	排紙突当て板	Paper exit pressure plate	1
	5C411110	排紙駆動プーリ / A (Z=30)	Paper exit driving pulley/A (Z=30)	11		5C411500	側面カバー / 上	Side cover/Upper	3
	5C411120	搬送駆動プーリ / A (Z=34/24)	Conveyance driving pulley/A (Z=34/24)	11		5C411510	側面カバー / 右	Side cover/Right	3
	5C411130	スライドプーリ (Z=24)	Slide pulley (Z=24)	11		5C411520	側面カバー / 左	Side cover/Left	3
	5C411140	排紙プーリ (Z=43)	Paper exit pulley (Z=43)	11		5C411550	排紙組	Paper exit assembly	9
	5C411150	駆動プーリ / A (Z=40/24)	Driving pulley/A (Z=40/24)	11		5C411560	排紙ガイドステー	Paper exit guide stay	9
	5C411160	スライドギア / A (Z=100)	Slide gear/A (Z=100)	11		5C411570	昇降ステー	Up-down stay	7
	5C411170	スライドギア / B (Z=100/48)	Slide gear/B (Z=100/48)	8		5C411580	昇降カバー / F	Up-down cover/F	7
	5C411180	スライドギア / C (Z=86/34)	Slide gear/C (Z=86/34)	8		5C411590	昇降カバー / R	Up-down cover/R	7
	5C411190	カップリングギア (Z=18)	Coupling gear (Z=18)	16		5C411600	補助板	Auxiliary plate	7
	5C411200	駆動連結ギア (Z=18)	Drive connecting gear (Z=18)	11		5C411610	スライドストップ / A	Slide stopper/A	7
●	5C411210	ベルト / A (L=285)	Belt/A (L=285)	11		5C510080	ベルトテンションバネ	Belt tension spring	13
●	5C411220	ベルト / B (L=609)	Belt/B (L=609)	11,12		5C510090	ステイプルスライドプーリ (Z=28)	Staple slide pulley (Z=28)	22
●	5C411220	ベルト / B (L=609)	Belt/B (L=609)	13					

SP欄の●印はサービスパーツです。
The parts with "●" only are available as spare parts.

- 65 -



5C4/5C5

SP	部品番号 Parts No.	部 品 名 称	Description	Fig. No.
●	5C510100	ステイブスライドギア / B (Z=55)	Staple slide gear/B (Z=55)	22
	5C510110	F N S モータ	FNS motor	26
	5C510130	排紙皿 / 下	Paper exit tray/Lower	2
	5C510140	ストップ基板	Stopper board	22
	5C510150	スライド部材	Slide part	22,25
	5C510160	解除ストップ	Release stopper	22
	5C510170	ストップバネ / 中	Stopper spring/Middle	22
	5C510180	レバー揺動カム	Lever locking cam	22
	5C510190	レバー揺動歯車 (Z=36)	Lever locking gear (Z=36)	22
	5C510200	軸支持カラー	Shaft support collar	22
	5C510210	解除レバー	Release lever	22
	5C510220	ストップシート	Stopper sheet	22
	5C510230	解除バネ / 2	Release spring/2	22
	5C510240	センサカバー	Sensor cover	21
●	5C510250	紙規制板 / 前	Paper regulating plate/Front	21
●	5C510260	紙規制板 / 奥	Paper regulating plate/Rear	21
	5C510270	ガイド板	Guide plate	21
	5C510280	搬送ガイド板 / 1	Conveyance guide plate/1	21
	5C510290	搬送ガイド板 / 2	Conveyance guide plate/2	21
	5C510300	解除部材	Release part	21
	5C510310	解除バネ / 2	Release spring/2	21
	5C510320	搬送ガイドシート / A	Conveyance guide sheet/A	22
	5C510330	搬送ガイドシート / B	Conveyance guide sheet/B	22
	5C510340	紙ストップ底板	Paper stopper bottom plate	25
	5C510350	ガイド板 / A	Guide plate/A	25
	5C510360	紙ストップ押さえ	Paper stopper holder	25
	5C510370	紙ストップ	Paper stopper	25
	5C510380	ガイド板 / B	Guide plate/B	24
	5C510390	搬送支点板 / 前	Conveyance fulcrum plate/Front	24
	5C510400	ガイドシート / A	Guide sheet/A	24
●	5C510410	搬送ローラ / A	Conveyance roller/A	24
●	5C510420	搬送ローラ / B	Conveyance roller/B	24
	5C510430	折りブレード	Fold down blade	26
	5C510440	ガイド軸受 / A	Guide shaft holder/A	26
	5C510450	ガイド軸受 / B	Guide shaft holder/B	26
	5C510460	折りアーム / 上	Fold down arm/Upper	23
	5C510470	折りアーム / 下	Fold down blade/Lower	23
	5C510480	押圧アーム / 前	Pressure arm/Front	23
	5C510490	押圧アーム / 奥	Pressure arm/Rear	23
●	5C510500	折りローラ / 上	Fold down roller/Upper	23

SP欄の ● 印はサービスパーツです。
The parts with "●" only are available as spare parts.

SP	部品番号 Parts No.	部 品 名 称	Description	Fig. No.
●	5C510510	押圧ローラ	Pressure roller	23
	5C510520	紙折りバネ / 上	Paper hold down spring/Upper	23
	5C510530	紙折りバネ / 下	Paper hold down spring/Lower	23
	5C510540	押圧バネ	Pressure spring	23
	5C510550	ジャム解除ノブ	Jam release knob	23
	5C510560	センサ取り付け板 / B	Sensor mount plate/B	23
	5C510570	アクチュエタ / 3	Actuator/3	23
	5C510580	アクチュエタ / 4	Actuator/4	23
●	5C510590	センサ押圧バネ / 1	Sensor pressure spring/1	23
	5C510600	センサ取付ステー	Sensor mount stay	23
	5C510610	アイドラーカラー	Idler collar	27
	5C510620	排紙ガイド板 / 上	Paper exit guide plate/Upper	23
	5C510630	排紙ガイド板 / 下	Paper exit guide plate/Lower	23
	5C510640	調整カバー / 1	Adjusting cover/1	23
	5C510650	カムフォロア軸受	Cam follower shaft holder	26
	5C510660	規制ゴム	Regulating rubber	23,27
	5C510670	バネ	Spring	27
●	5C510680	折りローラ / 下	Fold down roller/Lower	23
	5C510690	ガイドシート / B	Guide sheet/B	25
	5C510700	紙規制底板 / 2 カシメ	Paper regulating plate/2 combined	21
	5C510710	搬送プーリ / A (Z=20)	Conveyance pulley/A (Z=20)	27
	5C510720	搬送プーリ / B (Z=16)	Conveyance pulley/B (Z=16)	27
	5C510730	搬送プーリ / C (Z=25)	Conveyance pulley/C (Z=25)	27
	5C510740	搬送プーリ / D (Z=21)	Conveyance pulley/D (Z=21)	27
	5C510750	紙折りプーリ (Z=30)	Paper fold down pulley (Z=30)	27
	5C510760	押圧プーリ (Z=36)	Pressure pulley (Z=36)	27
	5C510770	駆動プーリ (Z=16)	Driving pulley (Z=16)	27
	5C510780	アイドラープーリ / A (Z=20/33)	Idler pulley/A (Z=20/33)	27
	5C510790	アイドラープーリ / B (Z=20/24)	Idler pulley/B (Z=20/24)	27
	5C510800	逆転プーリ (Z=20)	Reversal pulley (Z=20)	27
	5C510810	ブレードアイドラーギア (Z=25/33)	Blade idler gear (Z=25/33)	26
●	5C510820	ブレード駆動カム (Z=114)	Blade driving cam (Z=114)	26
	5C510830	押圧ギア (Z=30)	Pressure gear (Z=30)	27
	5C510840	押圧アイドラー / A (Z=20)	Pressure idler/A (Z=20)	27
	5C510850	押圧アイドラー / B (Z=46)	Pressure idler/B (Z=46)	27
●	5C510860	ベルト / J (L=354)	Belt/J (L=354)	25
●	5C510870	ベルト / K (L=144)	Belt/K (L=144)	27
●	5C510880	逆転ベルト (L=378)	Reversal belt (L=378)	27
●	5C510890	搬送ベルト (L=381)	Conveyance belt (L=381)	24
●	5C510900	駆動ベルト / A (L=882)	Driving belt/A (L=882)	27

- 66 -



5C4/5C5

SP	部品番号 Parts No.	部 品 名 称	Description	Fig. No.
●	5C510910	駆動ベルト / B (L=237)	Driving belt/B (L=237)	27
●	5C510920	駆動ベルト / C (L=285)	Driving belt/C (L=285)	27
●	5C510930	駆動ベルト / D (L=318)	Driving belt/D (L=318)	27
●	5C510940	ベルト / M (L=386)	Belt /M (L=386)	22
●	5C510950	ストップモータ	Stopper motor	22
●	5C510960	給紙モータ	Paper feed motor	27
●	5C510970	F N S 束線 / 1	FNS wiring/1	30
	5C510980	F N S 束線 / 3	FNS wiring/3	25,30
	5C510990	F N S 束線 / 4	FNS wiring/4	30
	5C511000	F N S 束線 / 5	FNS wiring/5	30
	5C511010	F N S 束線 / 6	FNS wiring/6	30
	5C511020	F N S 束線 / 7	FNS wiring/7	30
	5C511030	F N S 束線 / 9	FNS wiring/9	23,26,30
	5C511050	排紙突当て板	Paper exit pressure plate	2
	5C511060	A D F 突き当て部材	ADF pressure part	18,19
	5C511070	カラー / C	Collar/C	17
	5C511080	ベルト押圧バネカシメ	Belt pressure spring combined	21
	5C511090	重送固定カラー	Double feed fixed collar	4
	5C511100	スイッチ絶縁シート	Switch insulating sheet	3
	5C511110	昇降ウォーム	Up-down worm	26
●	5C511120	S T R 駆動モータ	STR driving motor	17
	5C511130	コロ	Roller	1,2
	5C511140	解除ノブ	Release knob	5
●	5C511150	軸受 / 2	Shaft holder/2	27
	5C511160	駆動プーリ / C (Z=30/24)	Driving pulley/C (Z=30/24)	12,13
	5C511170	ストップゴム	Stopper rubber	1,2
	5C511180	ロックレバー	Lock lever	1,2
	5C511190	ロックカム	Lock cam	14,15
	5C511200	ベルト押さえ板 / A	Belt holder plate/A	27
	5C511210	駆動プーリ / B (Z=24)	Driving pulley/B (Z=24)	4
	5C511220	カムフォロアスライドビス	Cam follower slide screw	23
	5C511250	ベルトテンションコロ	Belt tension roller	11
	5C511260	ベルト従動ローラ	Belt driven roller	24
	5C511270	解除コロ	Release roller	2
	5C511280	センサカバー	Sensor cover	6
●	5C511290	給紙駆動モータ	Paper feed driving motor	10
●	5C511430	制御部	Control unit	2
●	5C511450	R O M 組	ROM assembly	2
●	5C710620	インターロックスイッチ	Inter lock switch	3
	5C710710	開閉レバー	Open-close lever	4

SP欄の ● 印はサービスパーツです。
The parts with "●" only are available as spare parts.

- 67 -







KYOCERA MITA AMERICA, INC.

Headquarters:

225 Sand Road, P.O. Box 40008
Fairfield, New Jersey 07004-0008
TEL : (973) 808-8444
FAX : (973) 882-6000

New York Show Room:

149 West 51st street,
New York, NY 10019
TEL : (212) 554-2679
FAX : (212) 554-2625

Northeastern Region:

225 Sand Road, P.O. Box 40008
Fairfield, New Jersey 07004-0008
TEL : (973) 808-8444
FAX : (973) 882-4401

Midwestern Region:

225 Spring Lake Drive,
Itasca, Illinois 60143
TEL : (630) 250-7447
FAX : (630) 250-8787

Western Region:

14101 Alton Parkway,
P.O.Box 57006, Irvine,
California 92618-7006
TEL : (949) 457-9000
FAX : (949) 457-9119

Southeastern Region:

1500 Oakbrook Drive,
Norcross, Georgia 30093
TEL : (770) 729-9786
FAX : (770) 729-9873

Southwestern Region:

2825 West Story Road,
Irving, Texas 75038-5299
TEL : (972) 550-8987
FAX : (972) 570-4704

Dallas Parts Distribution Center & National Training Center:

2825 West Story Road,
Irving, Texas 75038-5299
TEL : (972) 659-0055
FAX : (972) 570-5816

KYOCERA MITA CANADA, LTD.

6120 Kestrel Road,
Mississauga, Ontario L5T 1S8
TEL : (905) 670-4425
FAX : (905) 670-8116

KYOCERA MITA MEXICO, S.A. DE C.V.

Av. 16 de Septiembre #407
Col. Santa Inés,
Delegación Azcapotzalco
México, D.F., C.P. 02130
TEL : 3-83-27-41
FAX : 3-83-78-04