

GENERAL PRECAUTIONS FOR INSTALLATION/SERVICING/ MAINTENANCE

1. When installing the Paper Feed Pedestal KD-1009 to the Copier, be sure to follow the instructions described in the "Unpacking/Set-Up Procedure for the KD-1009" booklet which comes with each unit of the KD-1009.
2. The KD-1009 should be installed by an authorized/qualified person.
3. When transporting/installing KD-1009, employ two persons and be sure to use the positions as indicated below. KD-1009 is fairly heavy and weight approximately 17 kg (37.5 lb), therefore pay full attention when handling it.

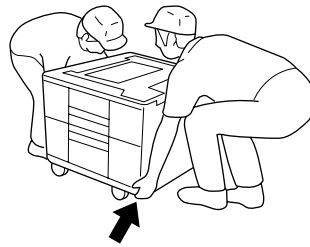

4. Before starting installation, servicing or maintenance work, be sure to turn off and unplug the copier first.
5. The KD-1009 is supplied with power from the copier, requiring no additional power source.
6. The KD-1009 should be grounded to the specified positions on the machine frame.
7. When servicing or maintaining the KD-1009, be careful about the rotating or operating sections such as gears, pulleys, sprockets, cams, belts, etc.
8. When parts are disassembled, reassembly is basically the reverse of disassembly unless otherwise noted in this manual or other related documents. Be careful not to reassemble small parts such as screws, washers, pins, E-rings, toothed washers to the wrong places.
9. Basically, the machine should not be operated with any parts removed or disassembled.
10. Delicate parts for preventing safety hazard problems (such as thermofuses, door switches sensors, etc. if any) should be handled/installed/adjusted correctly.
11. During servicing or maintenance work, be sure to check the nameplate and other cautionary labels (if any) to see if they are clean and firmly stuck. If not, take appropriate actions.
12. Use suitable measuring instruments and tools.
13. The PC board must be stored in an anti-electrostatic bag and handled carefully using a wristband, because the ICs on it may be damaged due to static electricity.
Caution: Before using the wrist band, pull out the power cord plug of the copier and make sure that there is no uninsulated objects in the vicinity.
14. For the recovery and disposal of used KD-1009, consumable parts and packing materials, it is recommended that the relevant local regulations/rules should be followed.

© Copyright 2000

TOSHIBA TEC CORPORATION

CONTENTS

1. SPECIFICATIONS	1-1
2. OVERVIEW	2-1
2.1 Front Sectional View	2-1
2.2 Layout of Electrical Parts	2-2
2.3 Electrical Parts	2-3
2.4 Harness Diagram	2-5
2.5 Circuit Diagram	2-9
2.6 Assembly of PC Board	2-12
2.7 Timing Chart	2-13
3. GENERAL OPERATION	3-1
3.1 Description of Operation	3-1
3.2 Error Detection	3-2
3.3 Flow Chart	3-3
4. DRIVE SYSTEM AND FEEDING OPERATION	4-1
4.1 Configuration and Drive System	4-1
5. DISASSEMBLY AND REPLACEMENT	5-1
5.1 Installation and Removal of Cassettes and Covers	5-1
5.2 PC Board	5-2
5.3 Upper and Lower Transport Roller (Plastic Rollers)	5-2
5.4 Motors	5-3
5.5 Feed/Separation/Pickup Roller	5-4
5.6 Switches and Sensors	5-6
6. PERIODIC MAINTENANCE	6-1

1. SPECIFICATIONS

Feeding method	Automatic feeding: 1 cassette installed from the front (One extra cassette (option) are available for the models with a DP2500, DP4500/3500)
Paper	Size: A5 – A3 Thickness: 64 – 80g/m ²
Transportation speed	Approx. 260mm/sec. (Models with a DP1600/2500) Approx. 400mm/sec. (Models with a DP4500/3500)
Capacity of cassette	Stack height: 60.5mm (approx. 550 sheets)
Dimensions	530 (W) × 536 (D) × 305 (H) mm
Weight	Approx. 17 kg (one cassette)
Power supply	5V, 24V (supplied from the copier)

2. OVERVIEW

2.1 Front Sectional View

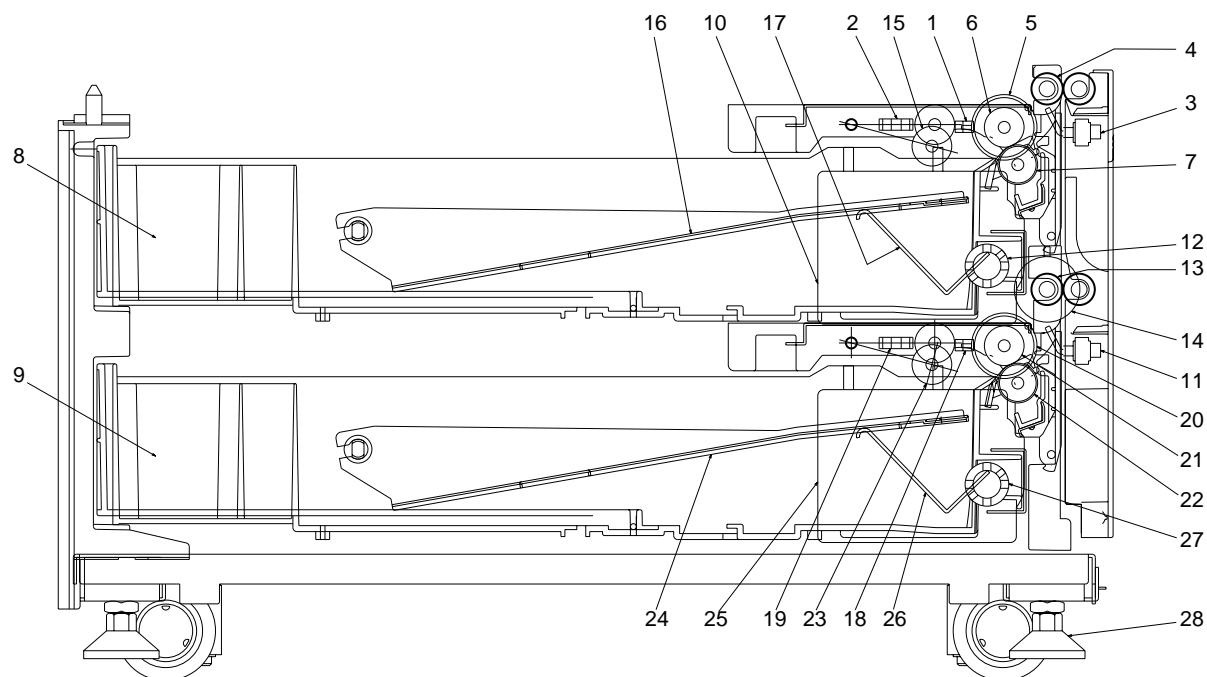

NO.	NAME	NO.	NAME
1	Upper cassette tray-up sensor (S4)	15	Upper cassette pickup roller
2	Upper cassette paper empty sensor (S6)	16	Upper cassette tray
3	Upper feed sensor (S2)	17	Upper cassette elevator
4	Upper transport roller	18	Lower cassette tray-up sensor (S5)
5	Upper cassette feed clutch (C2)	19	Lower cassette paper empty sensor (S7)
6	Upper cassette feed roller	20	Lower cassette feed clutch (C3)
7	Upper cassette separation roller	21	Lower cassette feed roller
8	Upper cassette	22	Lower cassette separation roller
9	Lower cassette	23	Lower cassette pickup roller
10	Upper cassette tray-up motor (M2)	24	Lower cassette tray
11	Lower feed sensor (S3)	25	Lower cassette tray-up motor (M3)
12	Upper cassette elevator coupling	26	Lower cassette elevator
13	Lower transport roller	27	Lower cassette elevator coupling
14	Transport clutch (C1)	28	Adjuster

2.2 Layout of Electrical Parts

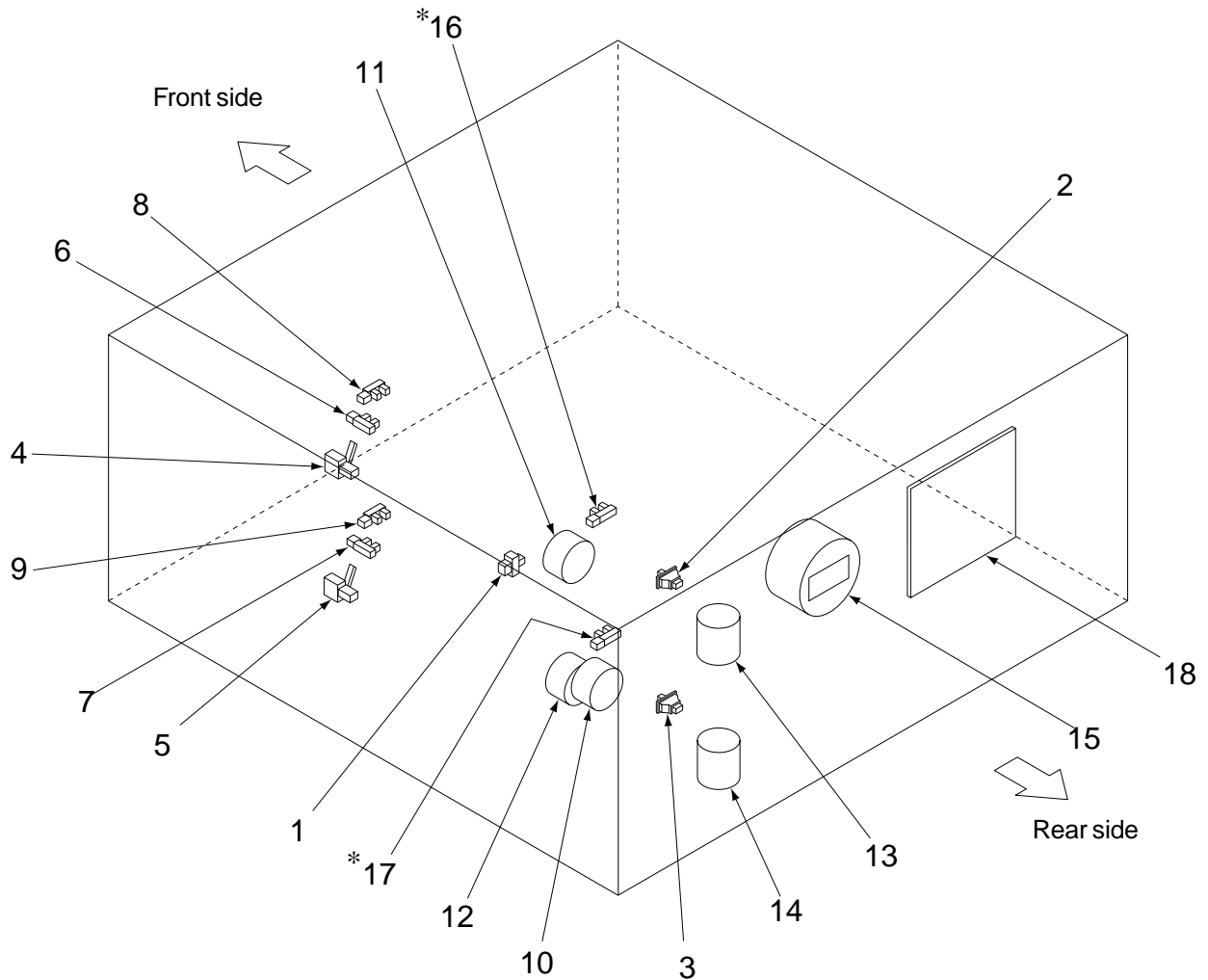

* for the DP4500/3500 only

NO.	NAME	NO.	NAME
1	Side cover open/close switch (S1)	10	Transport clutch (C1)
2	Upper cassette detection switch (S8)	11	Upper cassette feed clutch (C2)
3	Lower cassette detection switch (S9)	12	Lower cassette feed clutch (C3)
4	Upper feed sensor (S2)	13	Upper cassette tray-up motor (M2)
5	Lower feed sensor (S3)	14	Lower cassette tray-up motor (M3)
6	Upper cassette tray-up sensor (S4)	15	PFP motor (M1)
7	Lower cassette tray-up sensor (S5)	*16	Upper cassette paper stock sensor (S10)
8	Upper cassette paper empty sensor (S6)	*17	Lower cassette paper stock sensor (S11)
9	Lower cassette paper empty sensor (S7)	18	PC board (PWA)

2.3 Electrical Parts

(1) Motor

SYMBOL	NAME	FUNCTION	REMARKS
(M1)	PFP-MTR PFP motor	Drives feeding and transportation	Brushless motor
(M2)	T-UP-U-MTR Upper cassette tray-up motor	Lifts up the upper cassette tray	Brush motor
(M3)	T-UP-L-MTR Lower cassette tray-up motor	Lifts up the lower cassette tray	Brush motor

(2) Electromagnetic clutch

SYMBOL	NAME	FUNCTION	REMARKS
(C1)	TR-CLT Transport clutch	Drives transportation	
(C2)	FED-U-CLT Upper cassette feed clutch	Drives roller to pick up paper from the upper cassette	
(C3)	FED-L-CLT Lower cassette feed clutch	Drives roller to pick up paper from the lower cassette	

(3) Switches and Sensors

SYMBOL	NAME	FUNCTION	REMARKS
(S1)	SIDE-COV-SW Side cover open/close switch	Side cover open/close detection	Push switch
(S2)	FED-U-SNR Upper feed sensor	Detects paper from the upper cassette	Photo interrupter
(S3)	FED-L-SNR Lower feed sensor	Detects paper from the lower cassette	Photo interrupter
(S4)	TOP-U-SNR Upper cassette tray-up sensor	Detects if the upper cassette has been raised	Photo interrupter
(S5)	TOP-L-SNR Lower cassette tray-up sensor	Detects if the lower cassette has been raised	Photo interrupter
(S6)	EMP-U-SNR Upper cassette paper empty sensor	Detects lack of paper in the upper cassette	Photo interrupter
(S7)	EMP-L-SNR Lower cassette paper empty sensor	Detects lack of paper in the lower cassette	Photo interrupter
(S8)	CST-U-SW Upper cassette detection switch	Detects the availability of the upper cassette	Push switch
(S9)	CST-L-SW Lower cassette detection switch	Detects the availability of the lower cassette	Push switch

* for the DP4500/3500 only

SYMBOL	SPEC. NAME	FUNCTION	REMARKS
*(S10)	PST-U-SNR Upper cassette paper stock sensor	Detects that the paper stock is going short of the upper cassette	Photo interrupter
*(S11)	PST-L-SNR Lower cassette paper stock sensor	Detects that the paper stock is going short of the lower cassette	Photo interrupter

(4) PC board

SYMBOL	SPEC. NAME	FUNCTION	REMARKS
PWA	PWA-F-PFP-519 PC board	Drives feeding and moves trays	

2.4 Harness Diagram

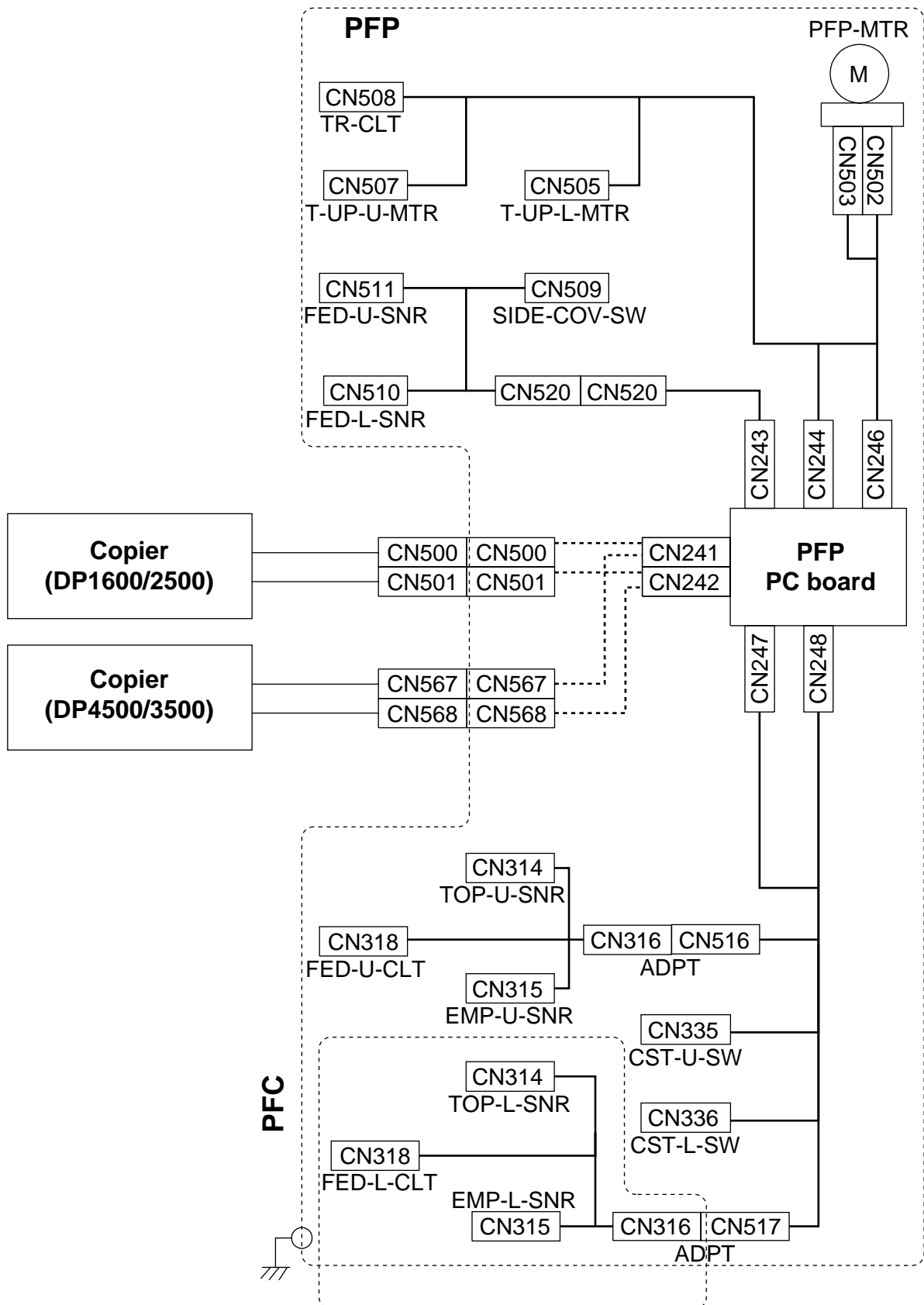

Copier (DP1600/2500)

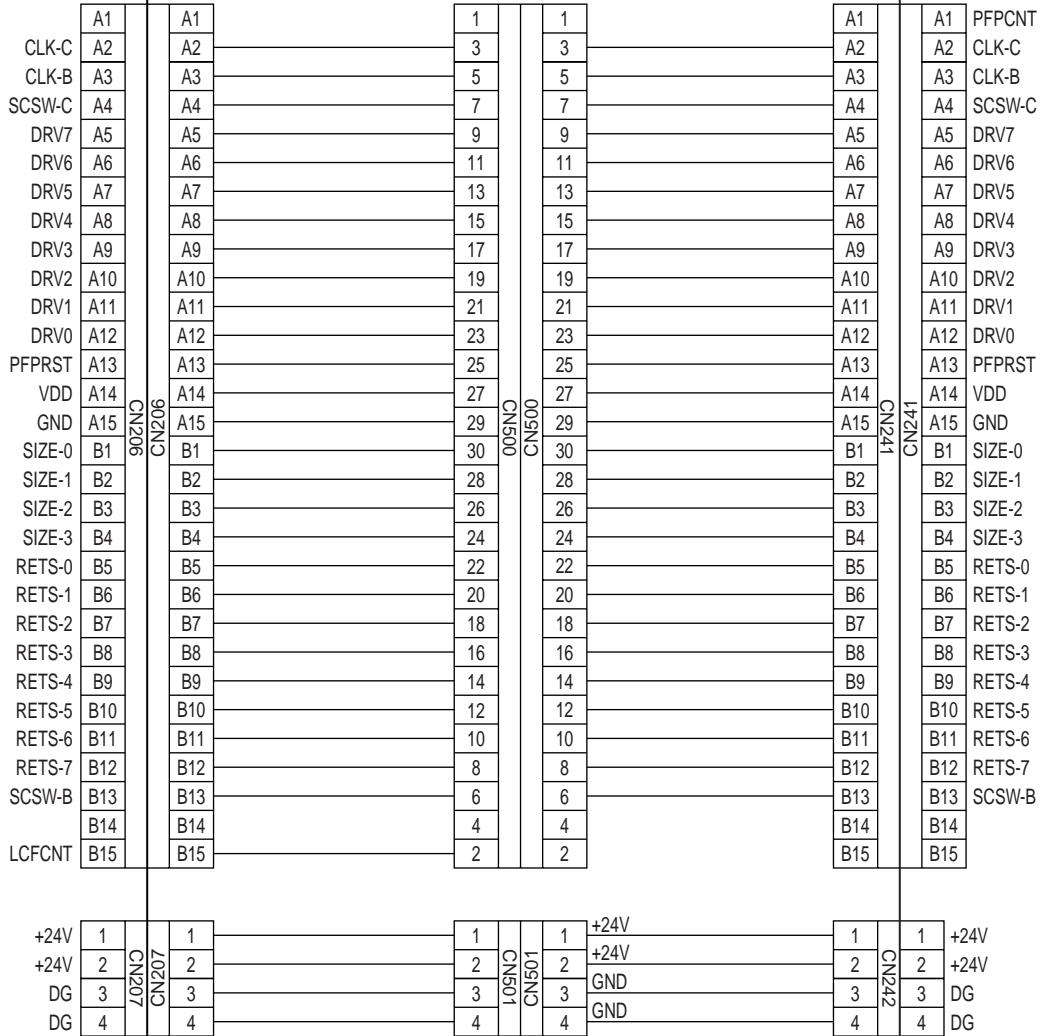

**PFP
PC board**

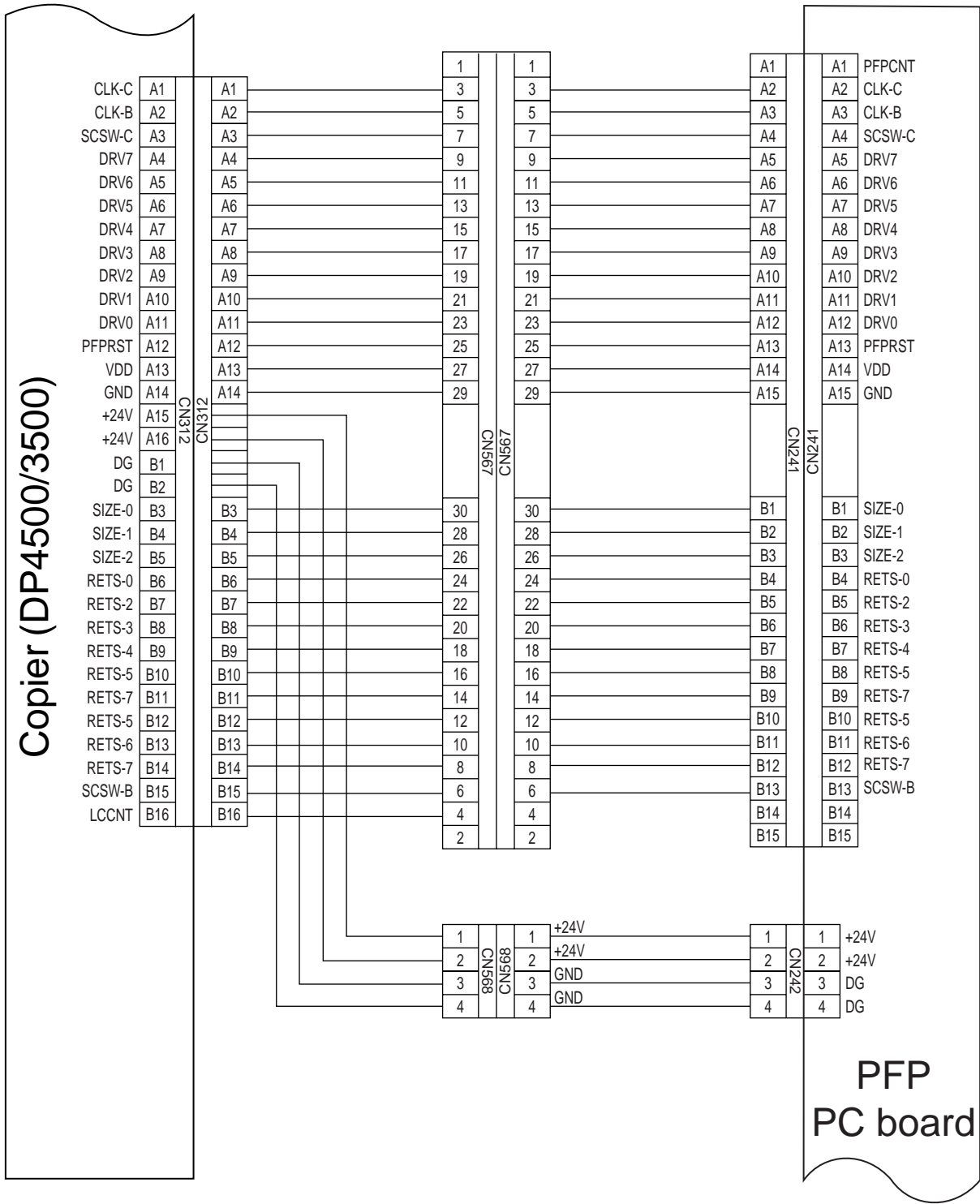

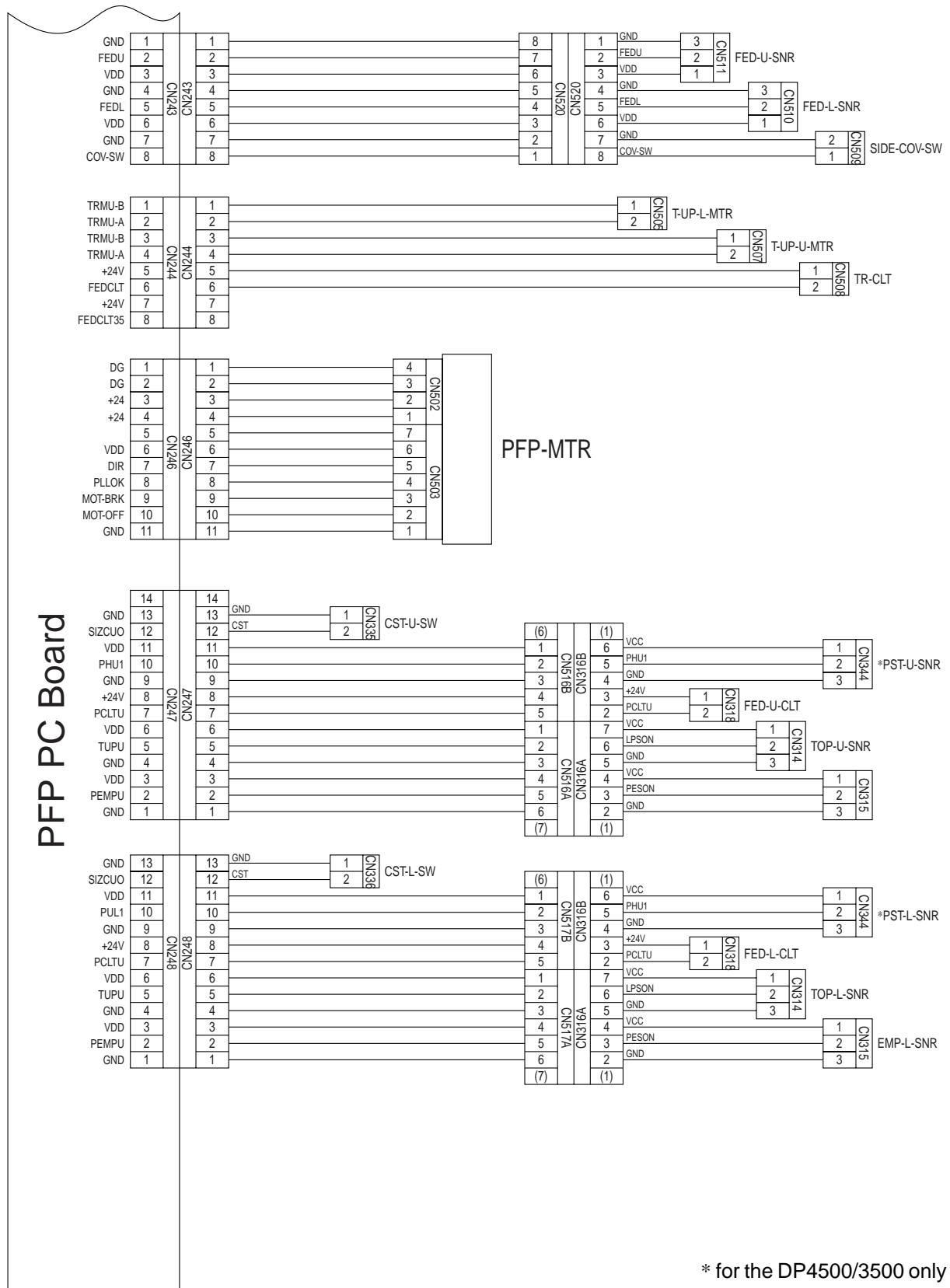

* for the DP4500/3500 only

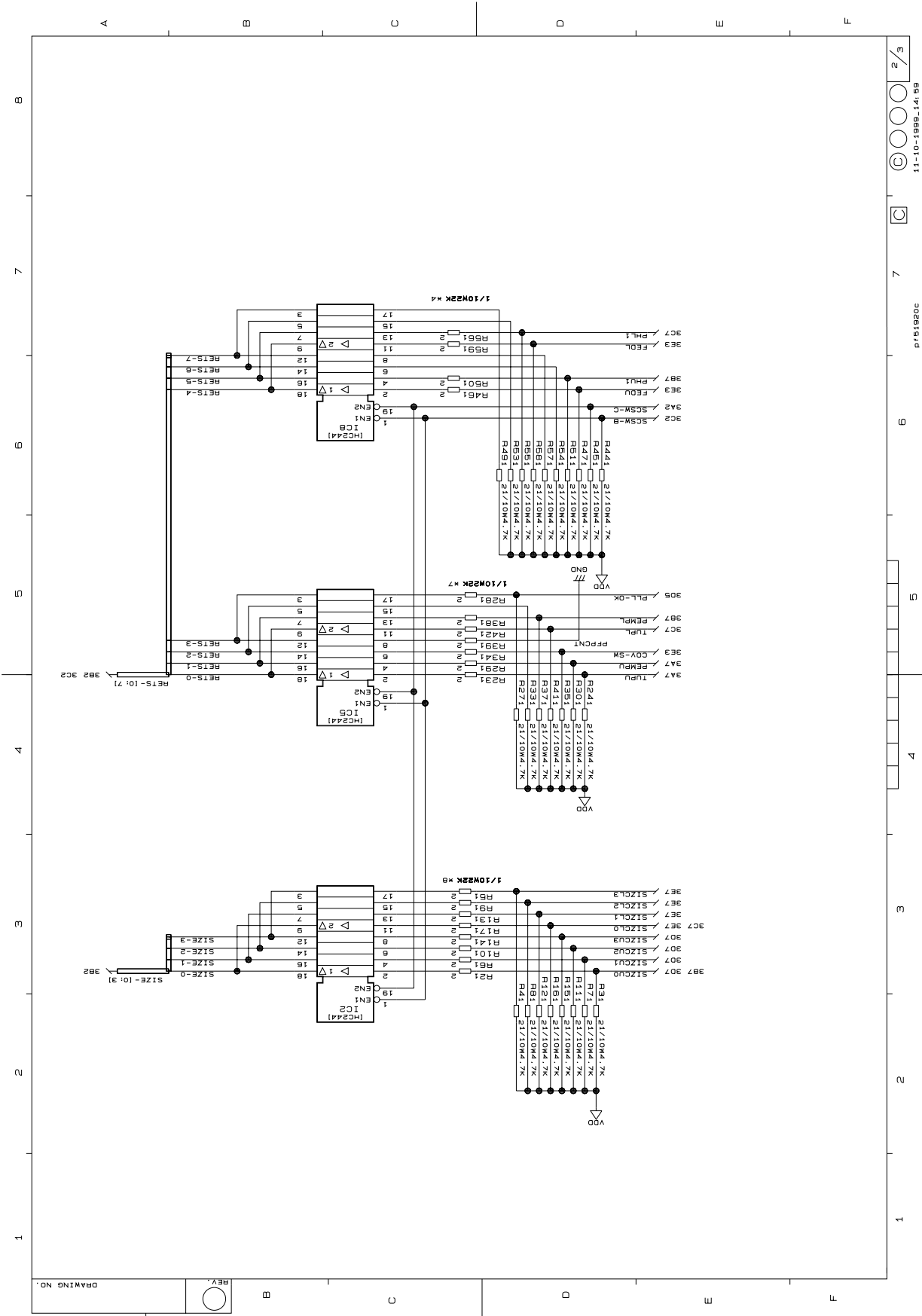

DRAWING NO. REV. 1

11-10-1999_14:56

2/3

REV. 1

DRAWING NO.

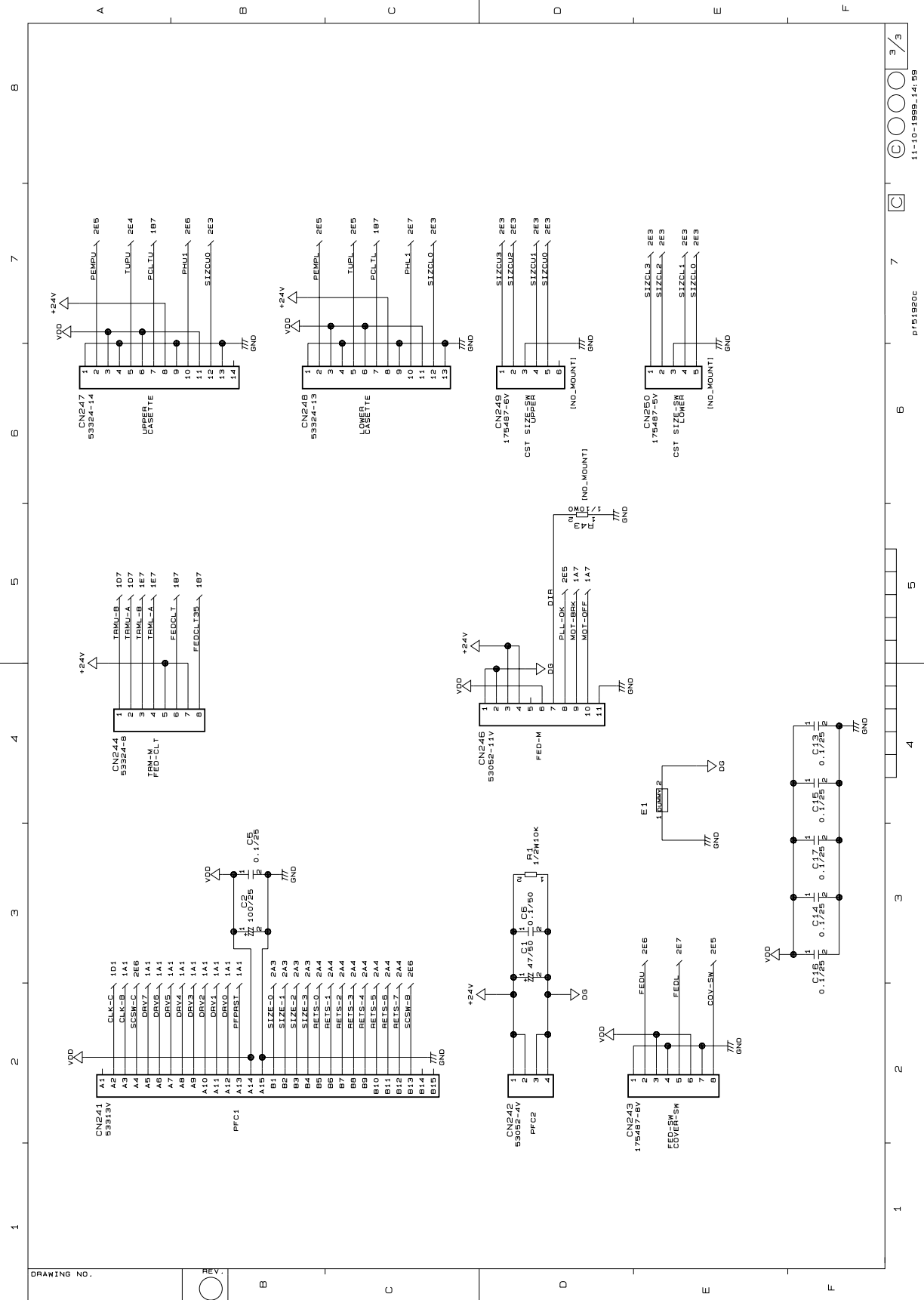

2.6 Assembly of PC Board

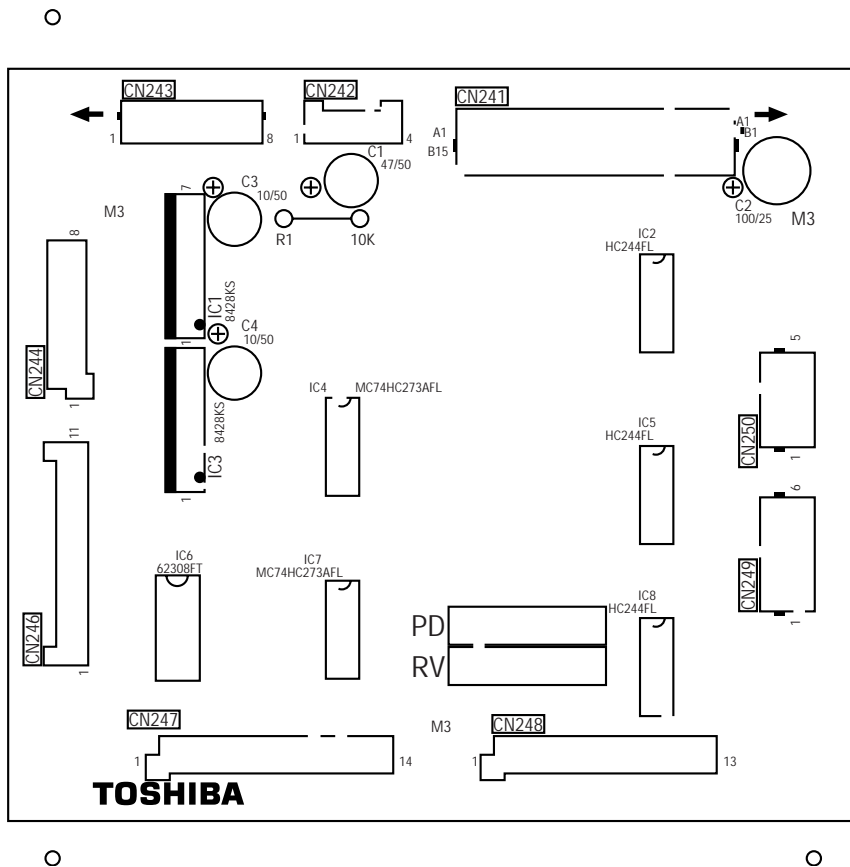

2.7 Timing Chart

(1) DP1600 (A4 sized sheet fed from the upper cassette)

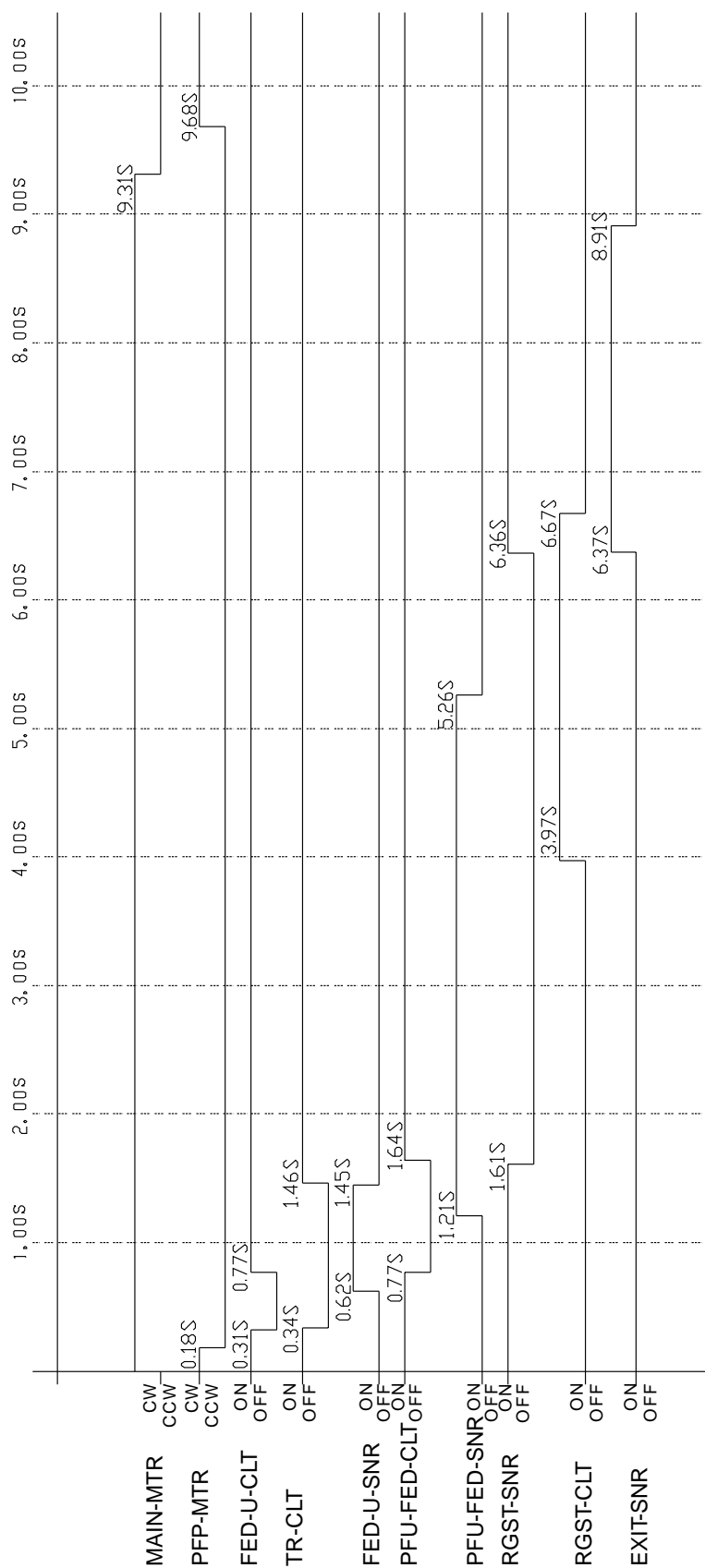

(2) DP2500 (A4 sized sheet fed from the upper cassette)

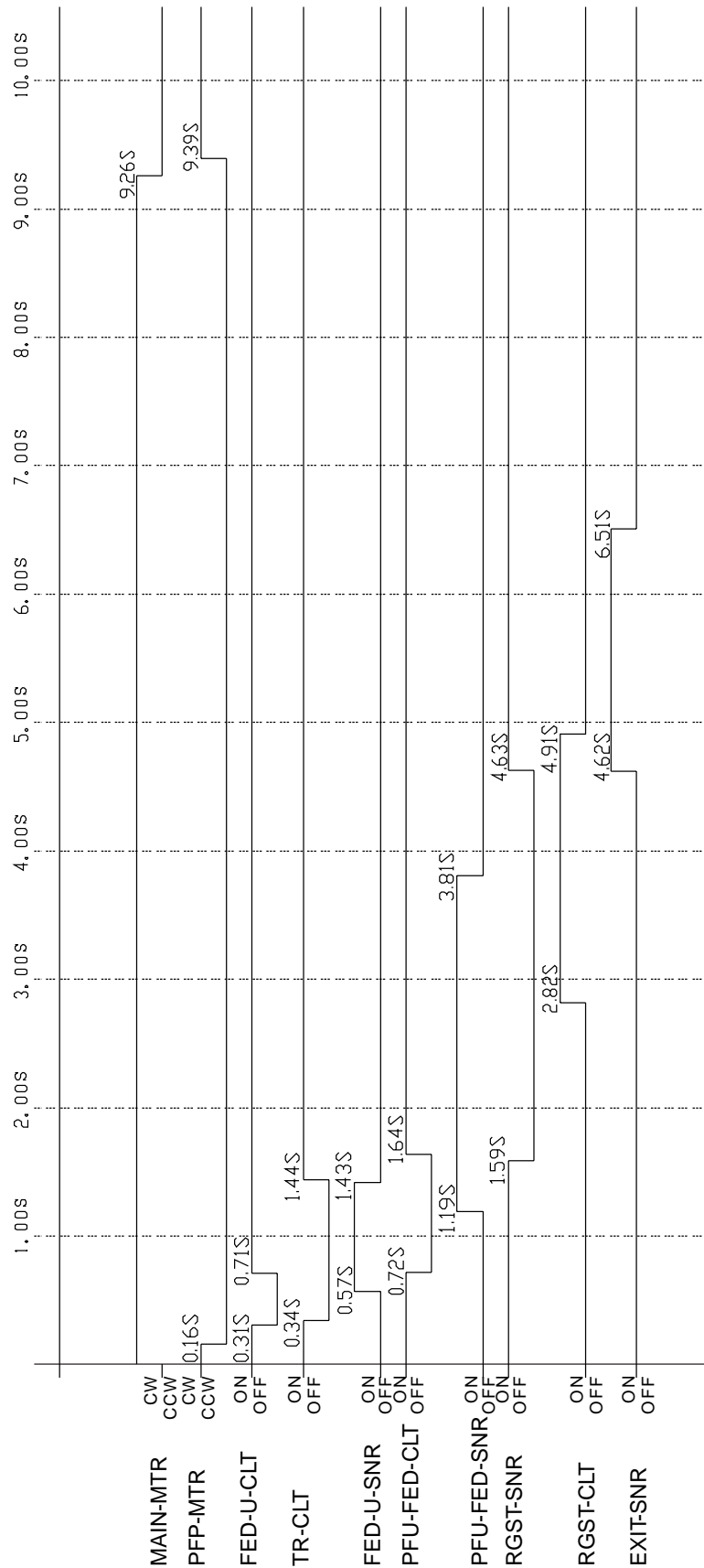

(3) DP4500/3500 (A4 sized sheet fed from the upper cassette)

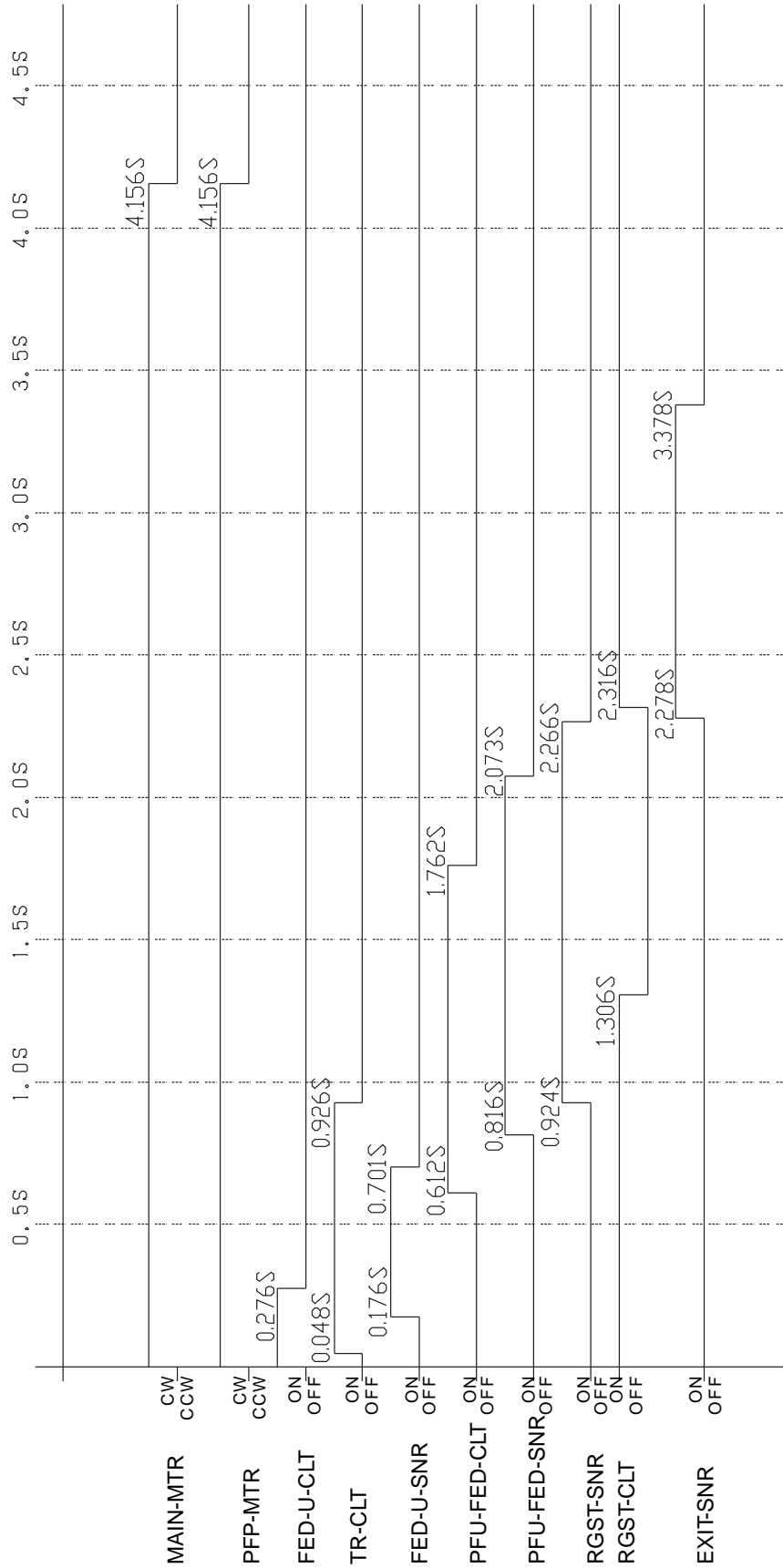

3. GENERAL OPERATION

3.1 Description of Operations

[A] From power ON to standby

- (1) When the copier is turned ON, power is also supplied to the feeder unit. Tray-up motor (M2)/(M3) is turned ON to raise tray. Tray-up sensor (S4)/(S5) is turned ON correspondingly, then the tray-up motor (M2)/(M3) is turned OFF to stop the tray. If the empty sensor (S6)/(S7) is OFF (H) at this time, it is judged that there is no paper in the cassette. If the empty sensor is ON (L), it is assumed that there is paper in the cassette, and the tray stay in the raised position until the cassette is pulled out.
- (2) If the power is turned ON when the cassette has been removed, the tray-up motor for that cassette is not turned ON. The tray is raised as soon as the cassette is installed, and it detects if there is paper in the cassette.
- (3) If either of the feed sensors (S2), (S3) is ON (there is paper in the transportation path) when the power is turned ON, that means paper jam has occurred and operation is disabled until the paper is removed.

[B] Standby status

- (1) Trays detect the paper as described above, and the copier goes into standby status.
- (2) The tray goes down automatically when the cassette is removed and it is raised as soon as the cassette is installed again and checks if there is paper in the cassette.

[C] From the start to the end of copying

- (1) The main motor of the copier is turned ON when the START key is pressed. About 0.1 sec. later, the PFP motor (M1) and the transport clutch (C1) are turned ON to drive the transport rollers.
- (2) When the copier judges that PFP is ready for feeding paper, it turns ON the feed clutch (C2)/(C3) of the selected cassette. This clutch drives the pickup roller and feed roller to feed paper from the tray.
- (3) The leading edge of the paper turns the feed sensor (S2)/(S3) ON. These are located right next to the exit side of the selected cassette. The feed clutch (C2)/(C3) is turned OFF and feeding from the cassette is completed.
- (4) The paper is transported to the copier by the PFP transport roller. If the trailing edge of the previously sent sheet still remains at the feed sensor when the leading edge of the paper reaches the feed sensor (S2)/(S3), the transport clutch (C1) is turned OFF to stop the transport of the paper. (In case of DP4500/3500, the transport clutch (C1) is not turned OFF until the registration operation is completed regardless of the size of the paper.)
- (5) The trailing edge of the paper turns the feed sensor (S2)/(S3) OFF. These are located right next to the exit side of the selected cassette. PFP then becomes ready for feeding the next sheet of paper, and the procedures (2) to (4) are repeated.
- (6) When the copying operation is completed, the main motor, PFP motor (M1) and transport clutch (C1) are turned OFF and the transport roller is stopped.

3.2 Error Detection

[A] Jam detection

- (1) Paper jams (E15), (E16) and (E32, E34, E35) [DP4500/3500: (E15, E16) (E30~E36)] occurs in the following cases.
 - a. Feed sensor (S2)/(S3) is not turned ON within 0.4 second after the feeding is started.
 - b. The leading edge of the paper does not pass the feed sensor (S2)/(S3) in the transport path within a fixed time.
- (2) Open the side cover of the paper feeder and remove all the paper remaining on the transport path and close the side cover to clear the jammed paper. If either of the feed sensors (S2)/(S3) is still ON when the side cover is closed, it is determined that there is still paper on the transport path and the paper jam status is not canceled.
- (3) When a paper jam occurs in the paper feeder during multiple copying, the sheet that was fed before the jam is copied normally.

[B] Call Service

- (1) The tray is raised when the power is turned ON or the cassette is inserted or removed.
If the tray-up sensor (S4)/(S5) is not turned ON within 8 (DP4500/3500: 12 seconds) seconds after the tray has started to raise, a message to the effect that the selected cassette of that level cannot be used is displayed in the control panel.
- (2) The state (1) are cleared by removing the cassette. (This state cannot be cleared by opening and closing the side cover)

3.3 Flow Chart

(1) DP1600/2500

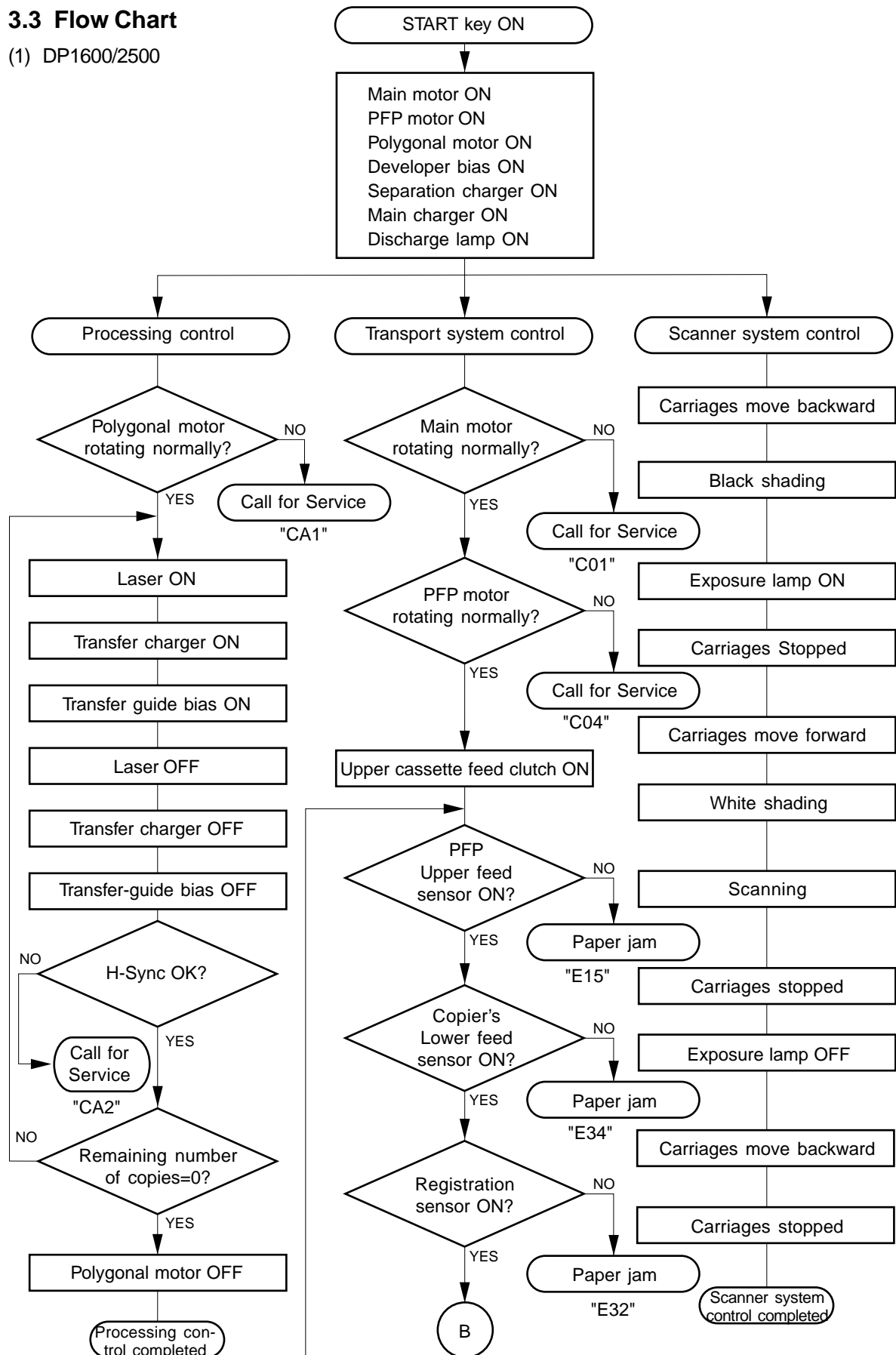

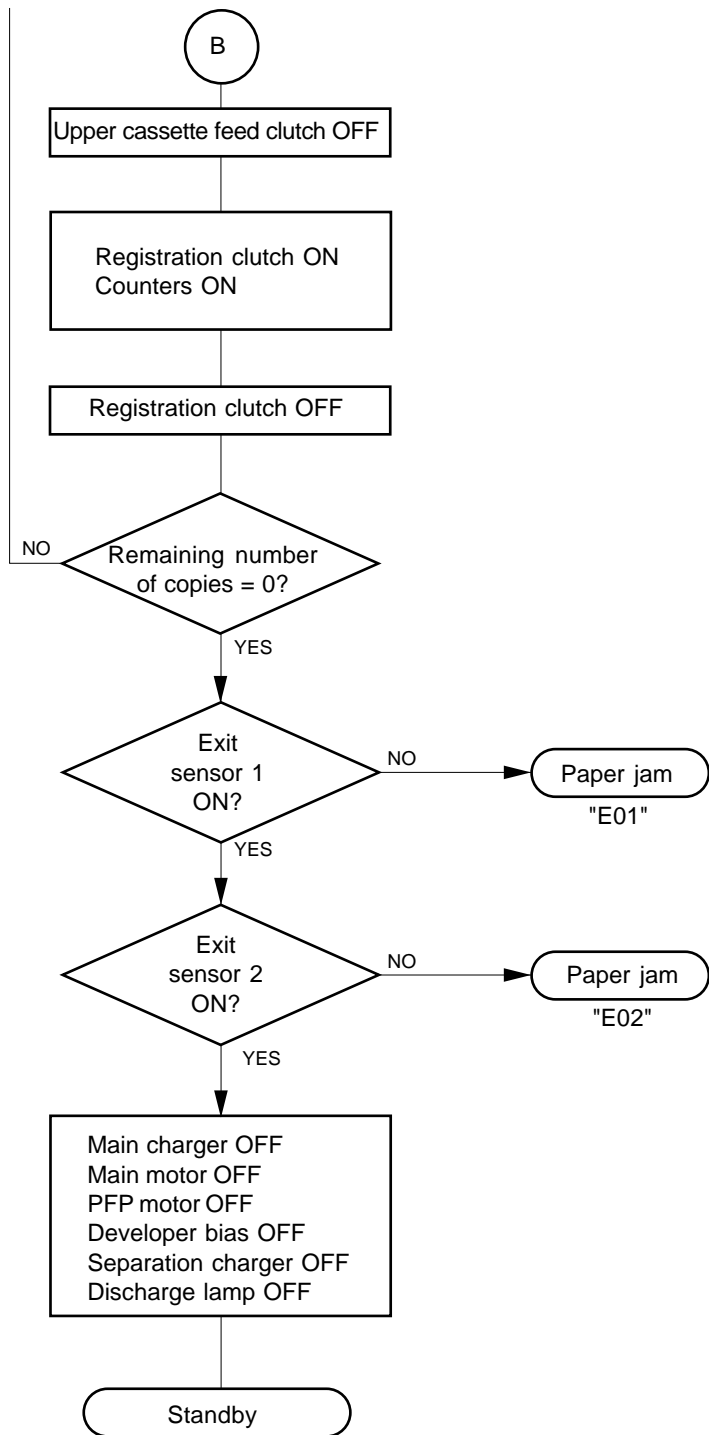

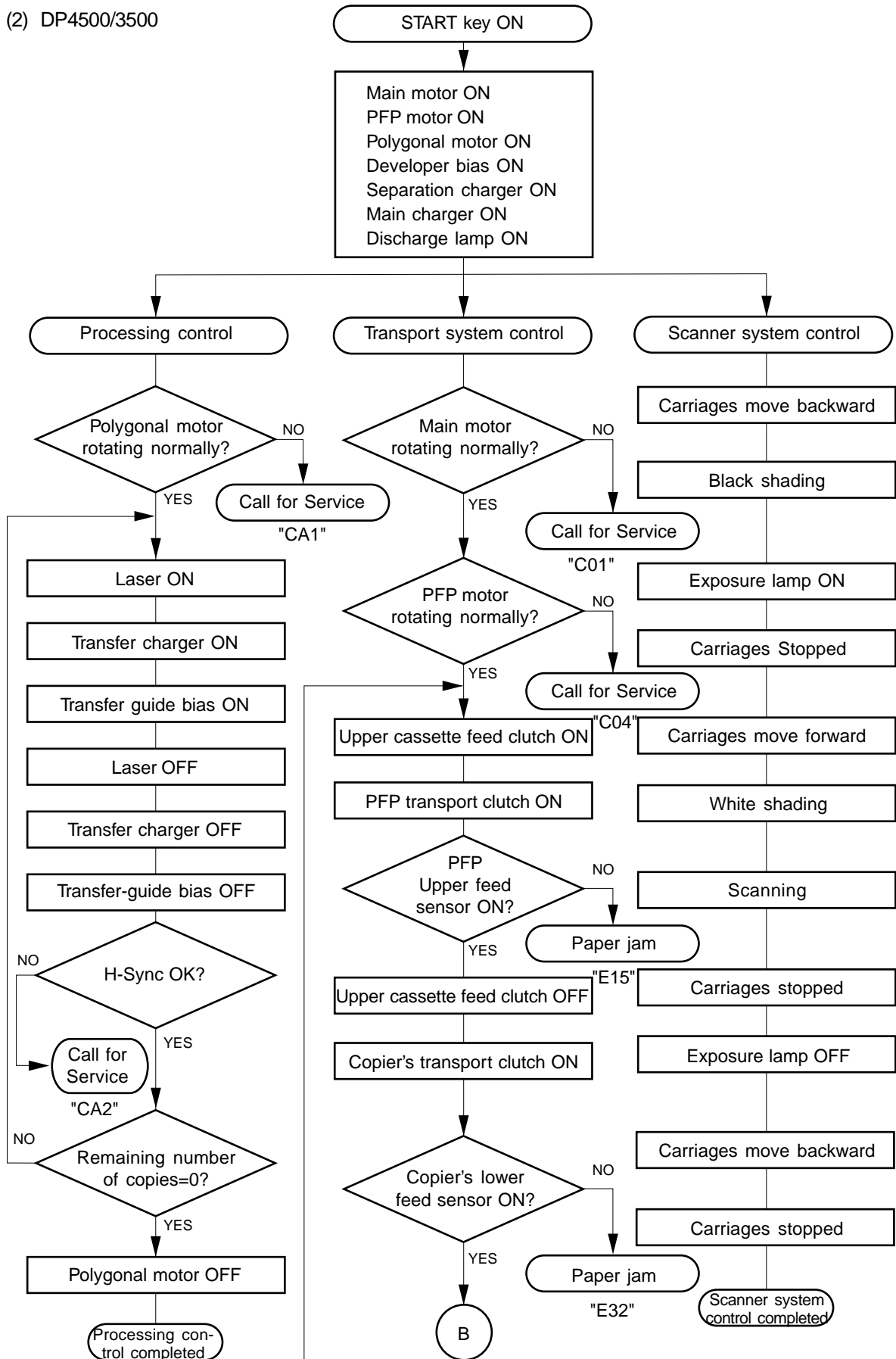

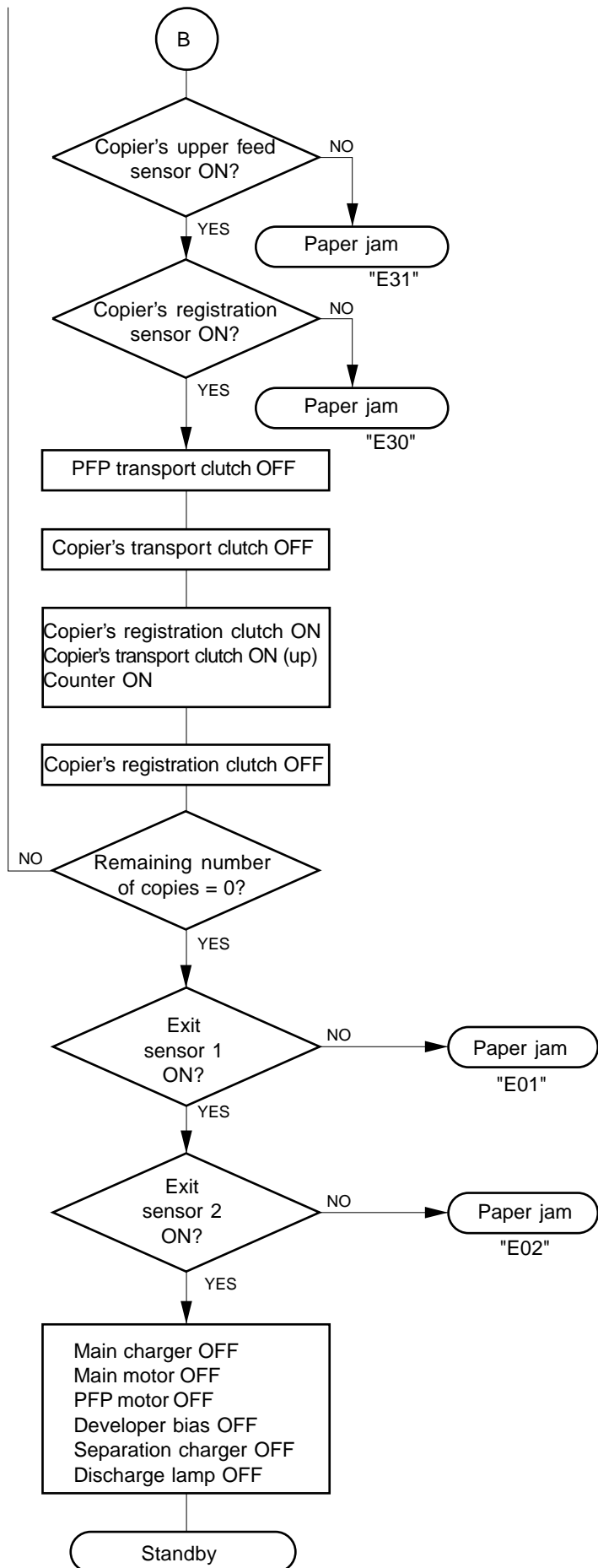

4. DRIVE SYSTEM AND FEEDING OPERATION

4.1 Configuration and Drive System

The Paper Feed Pedestal (PFP) mainly consists of the cassette, pickup roller, feed roller, separation roller, transport roller and drive systems for these components.

- Feeding/Transport system

The PFP motor drives the pickup roller, feed roller, separation roller and transport roller which are located in the feeding area.

- Cassette tray system

This system raises and lowers the trays.

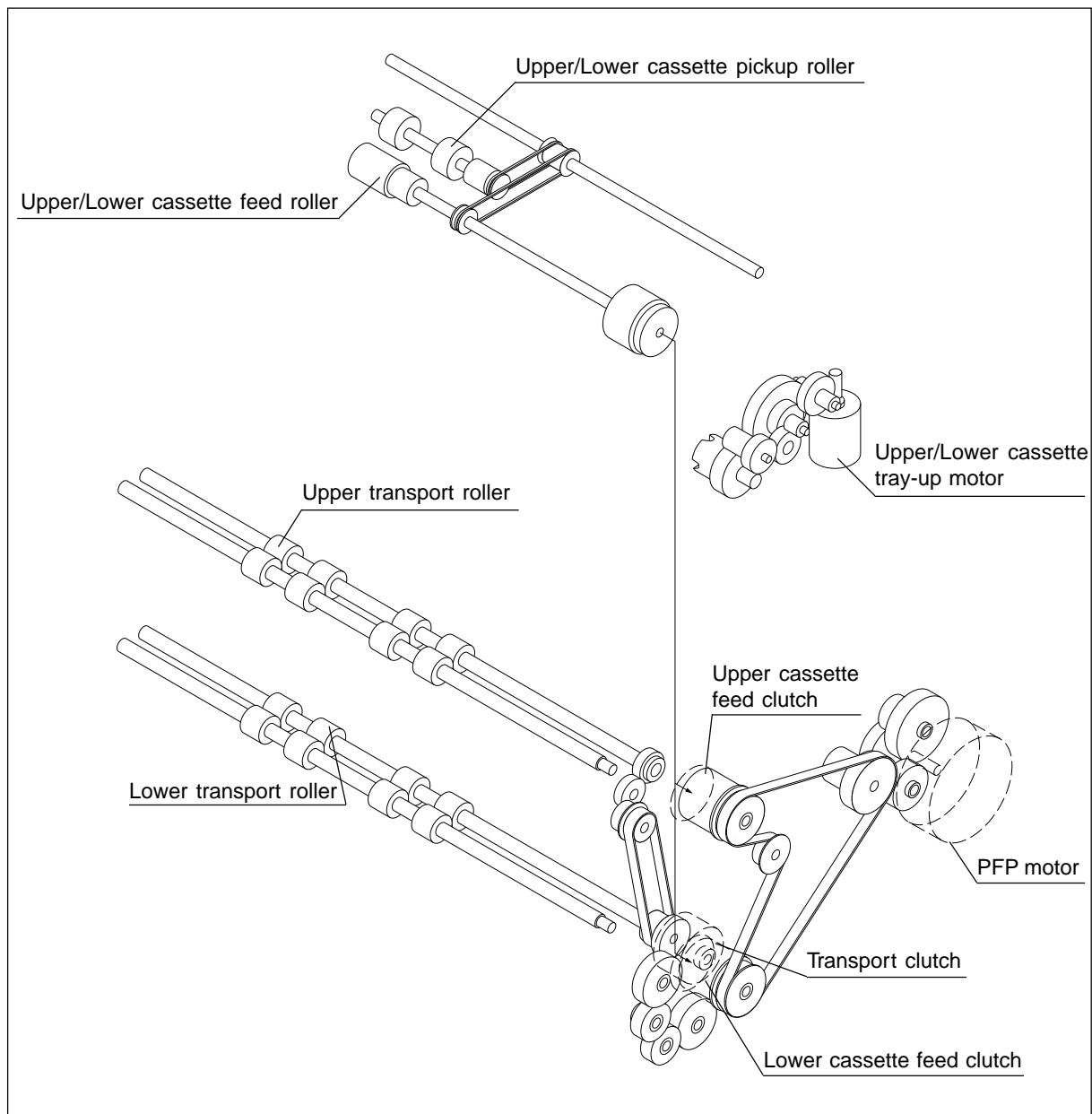

5. DISASSEMBLY AND RE-PLACEMENT

5.1 Installation and Removal of Cassettes and Covers

[A] Cassettes

- (1) Pull out the cassette fully and remove it while lifting it up.

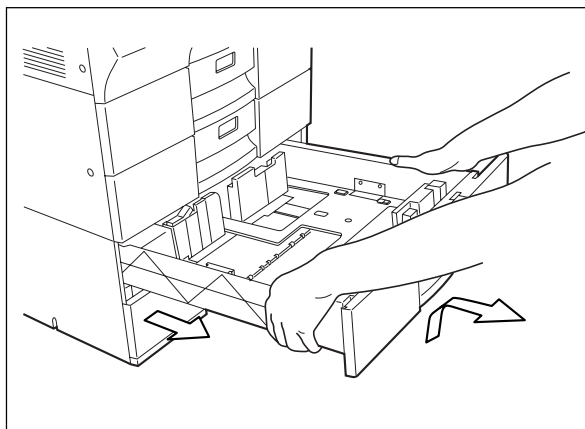

[B] Slot cover

- (1) Pull out the upper cassette.
- (2) Remove 2 screws and take off the slot cover.

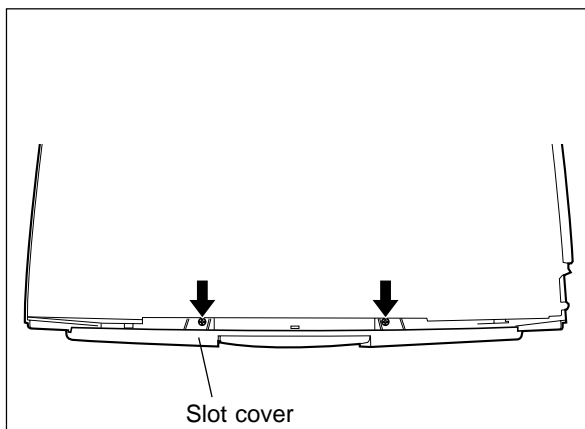

[C] Rear cover

- (1) Remove the 5 screws fixing the rear cover.
- (2) Remove the rear cover while lifting it up.

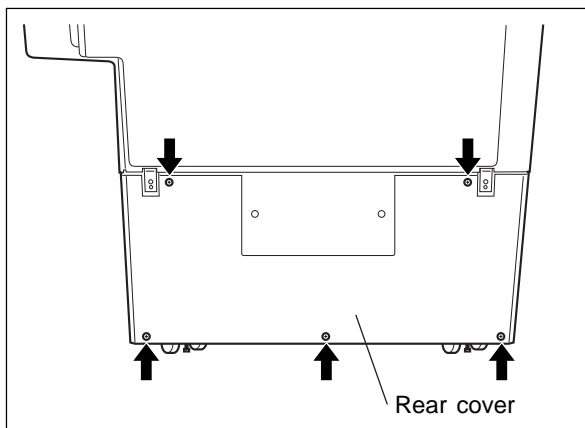

[D] Feeding-side front cover and Feeding-side rear cover

- (1) Remove 2 screws and take off the feeding-side front cover.
- (2) Remove 2 screws and take off the feeding-side rear cover.

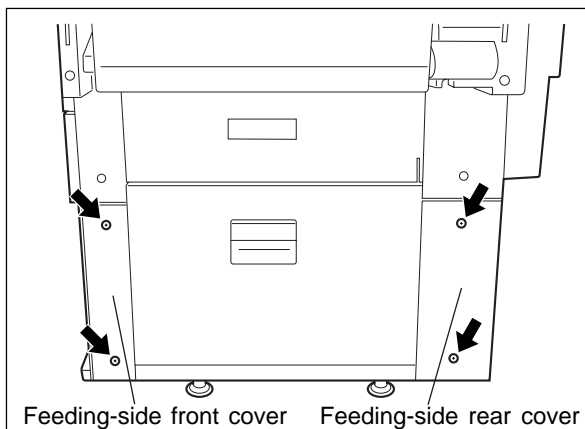

[E] Side cover

- (1) Open the side cover. Loosen the belt and remove it.
- (2) Disconnect one connector.

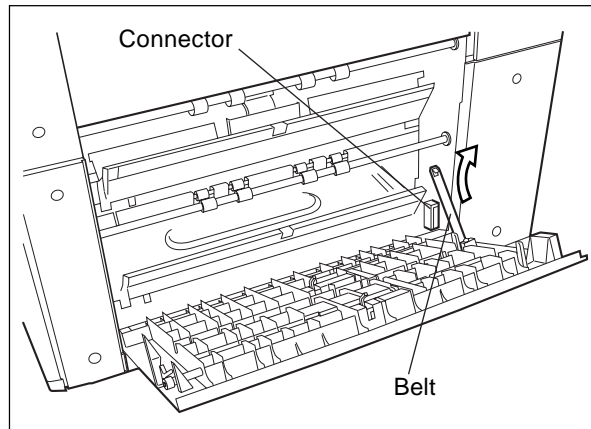

- (3) Remove the side cover.

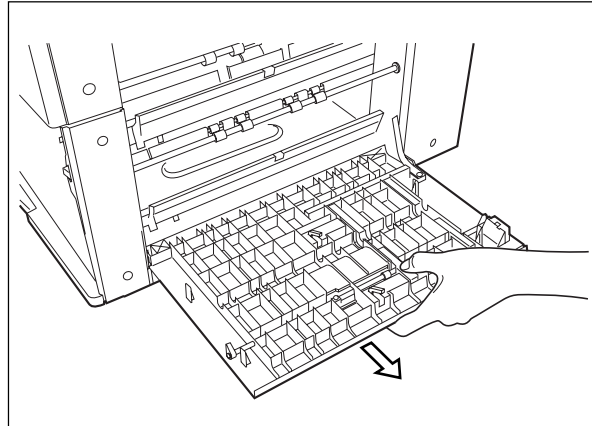

5.2 PC Board

- (1) Remove the rear cover.
- (2) Disconnect 7 connectors and detach 4 lock supports to remove the PC board.

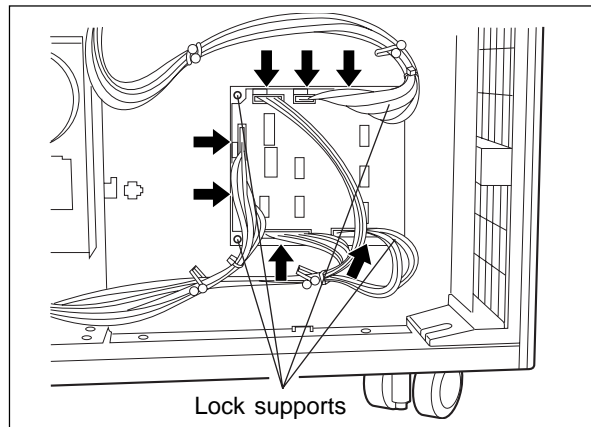

5.3 Upper and Lower Transport Rollers (Plastic Rollers)

- (1) Remove the side cover and the feeding-side front cover.
(When the upper transport roller is also removed, take off the feeding-side front cover of the copier.)
- (2) Detach the springs and bushings from the front and rear sides and take off the rollers.

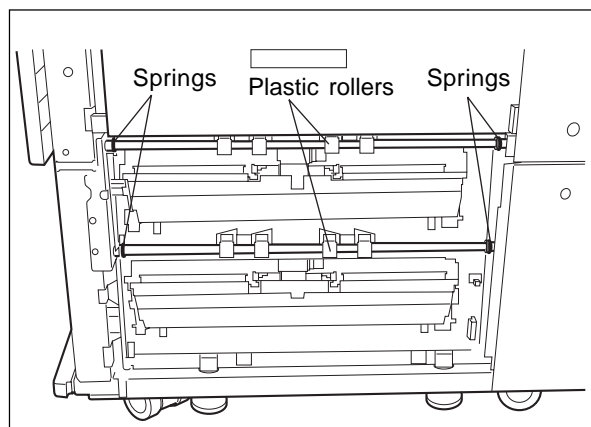

5.4 Motors

[A] Tray-up motor unit

- (1) Remove the rear cover.
- (2) Remove the harness from the 2 clamps.
- (3) Disconnect 3 connectors.
- (4) Remove 5 screws and take off the tray-up motor unit.

Note: Tray-up motor unit is connected with the copier with other harness. Do not disconnect them and place the unit nearby the copier.

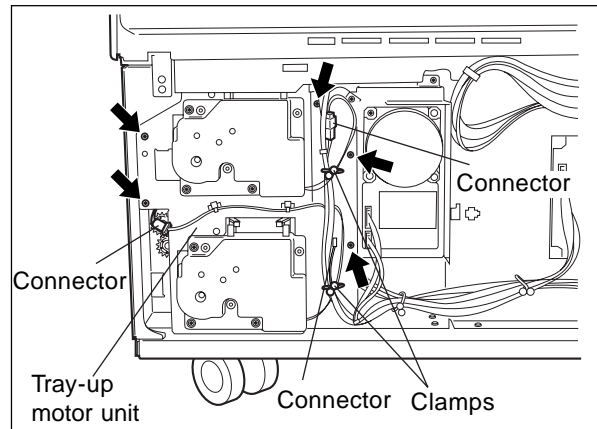

[B] PFP motor unit

- (1) Disconnect 2 connectors.
- (2) Remove 2 screws and take off the PFP motor.
- (3) Remove one screw and take off the lever shaft bracket.
- (4) Remove 4 screws and take off the PFP motor unit bracket.

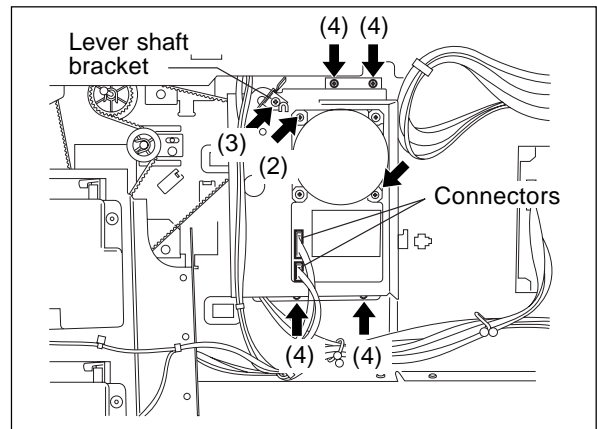

Note: The positions to attach the shift lever bracket and lever shaft bracket differ according to each model.

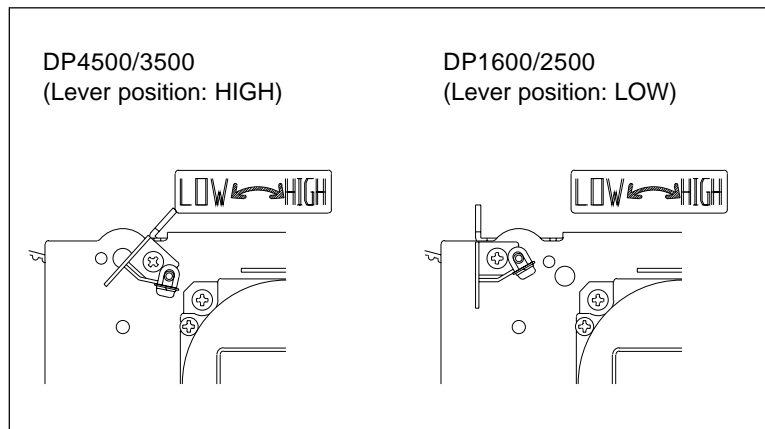

- (5) Remove the clip and pull out the lever shaft.
- (6) Take off the shift lever bracket. Remove the gears and belt from the PFP motor unit bracket.

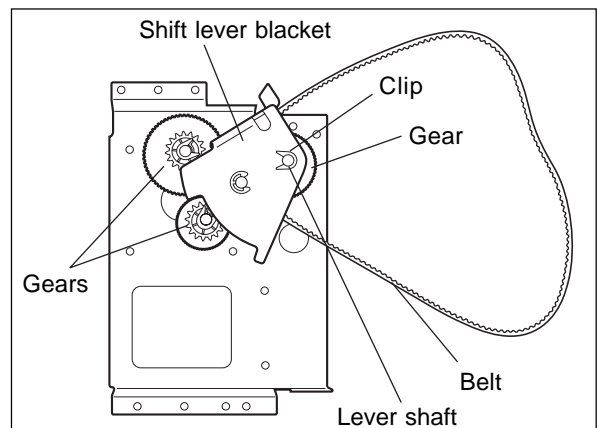

5.5 Feed/Separation/Pickup Rollers

[A] Feed unit

- (1) Pull out the cassette.
- (2) Remove one screw and take out the feed unit toward the front side.

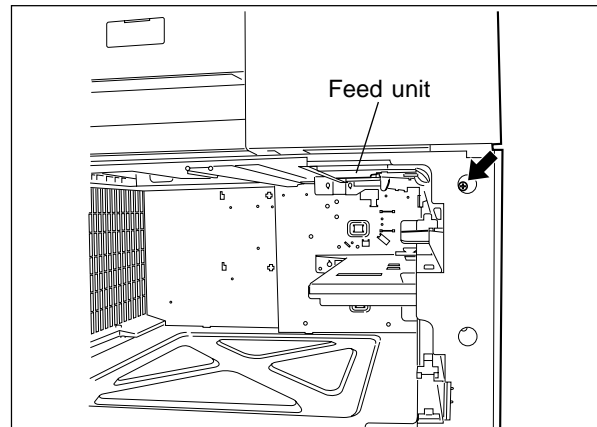

[B] Feed clutch

- (1) Disconnect one connector.
- (2) Remove 2 screws and take off the clutch bracket.
- (3) Loosen one setscrew.
- (4) Remove the feed clutch.

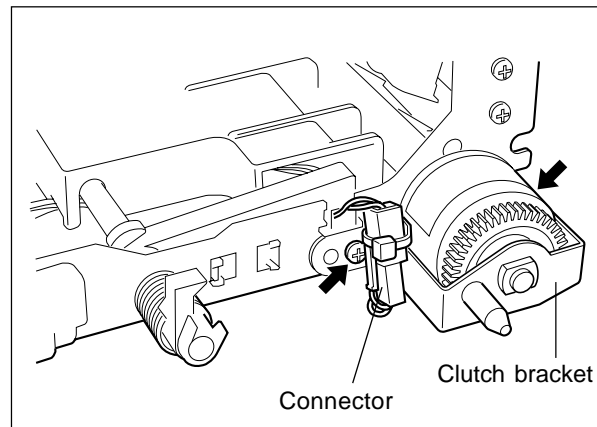

[C] Separation roller

- (1) Remove one screw and take off the separation roller holder.
- (2) Remove the lever from the holder and take off the separation roller along with its shaft.
- (3) Remove the cover, arbor, clutch spring, and then the separation roller from the shaft.

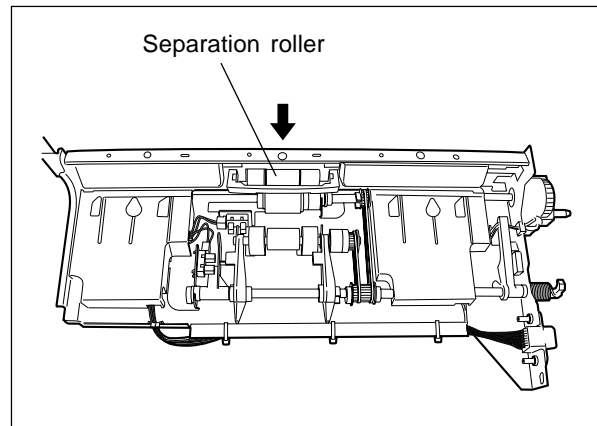

Note:

When reassembling the pickup roller, feed roller and separation roller, pay attention to the followings:

1. Put a pin into the pulley.
2. Set the timing belt securely on the pulleys.
3. The "lock" direction of each one-way clutch is different.

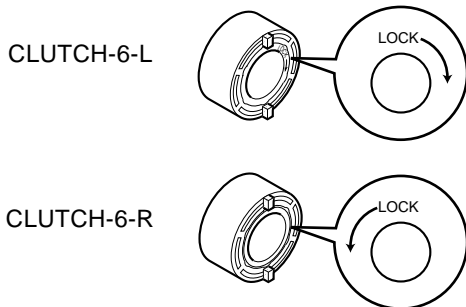

4. Fit the clips securely into the groove on the shaft.
5. Confirm that there is no oil staining etc. on the surface of the timing belt, pulleys and rollers.
6. Pay attention to the mounting direction of the rollers.

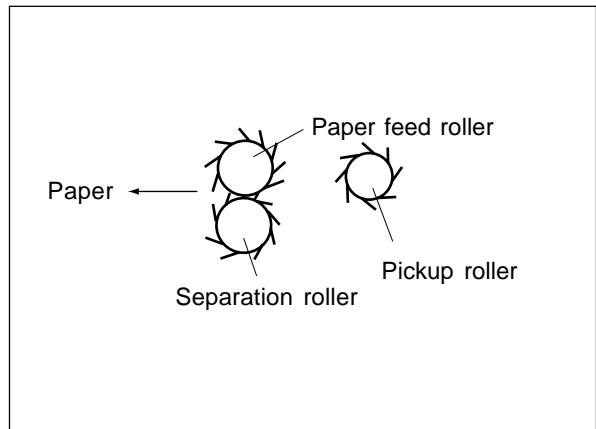
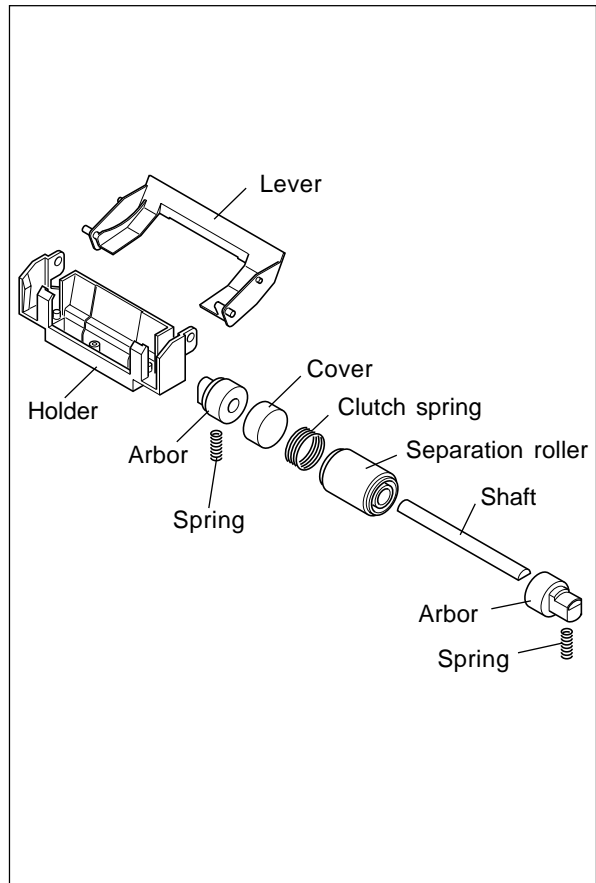

[D] Pickup roller

- (1) Remove the pickup roller from the pickup arm and take off the belt.

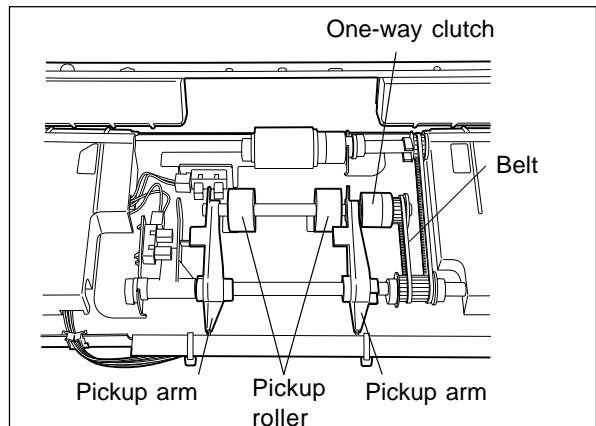

[E] Feed roller

- (1) Remove the clip and take off the feed roller in the direction of the arrow.

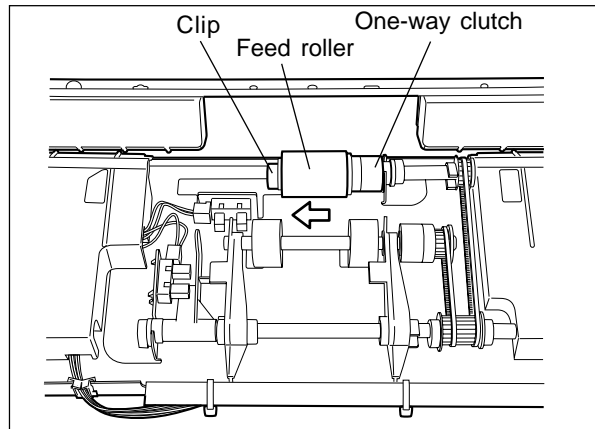

5.6 Switches and Sensors

[A] Side cover open/close sensor

- (1) Remove the side cover.
- (2) Release the latches and remove the sensor cover.
- (3) Disconnect one connector.
- (4) Release the latches and remove the sensor.

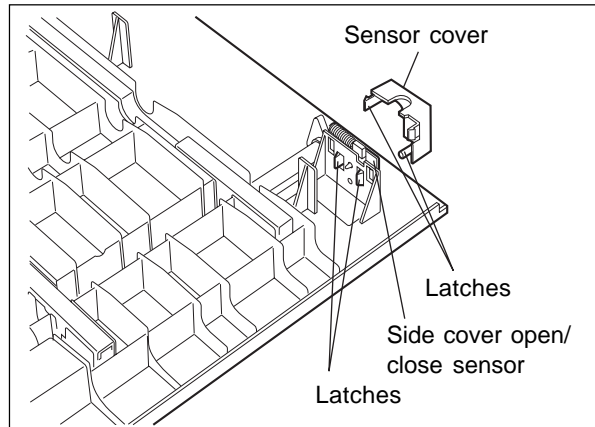

[B] Upper/lower feed sensors

- (1) Release the latches and remove the sensor cover.
- (2) Disconnect one connector.
- (3) Release the latches and remove the sensor.

Note: Upper and lower switches can be removed with the same procedure.

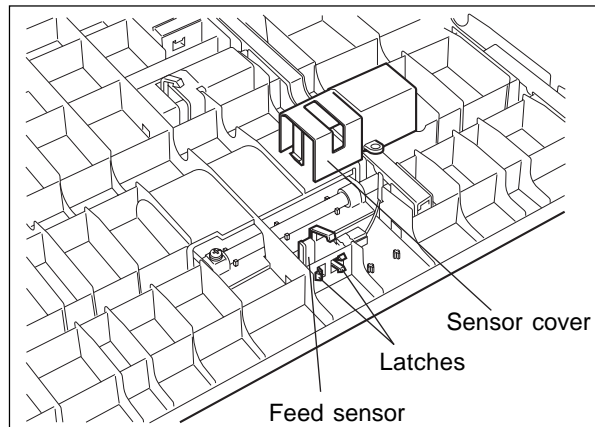

[C] Upper/lower cassette detection switches

- (1) Pull out the cassette.
- (2) Remove the rear cover.
- (3) Take off the tray-up motor unit and PFP motor unit.
- (4) Disconnect the connectors connected to the cassette detection switch.
- (5) Release the latches and remove the switch from the front side.

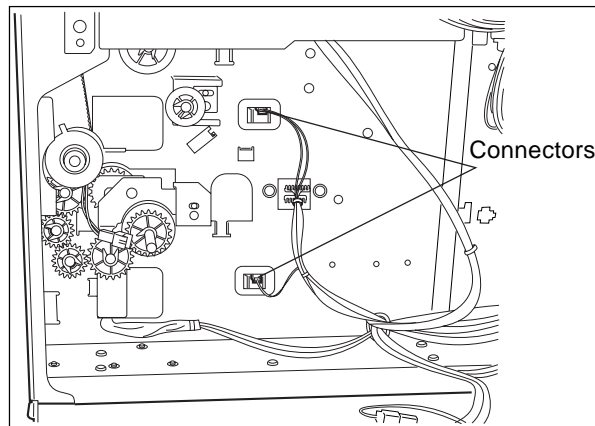

[D] Tray-up sensor and Paper empty sensor

- (1) Disconnect the connector and release the latches and remove the tray-up sensor.
- (2) Disconnect the connector and release the latches and remove the empty sensor.

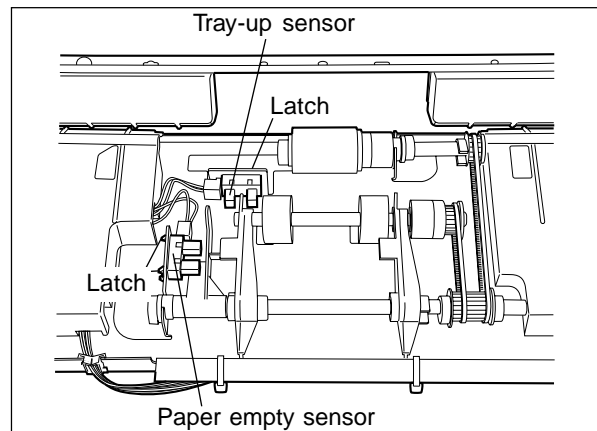

[E] Paper stock sensor (for the DP4500/3500 only)

- (1) Release the latches and remove the sensor.
- (2) Disconnect one connector.

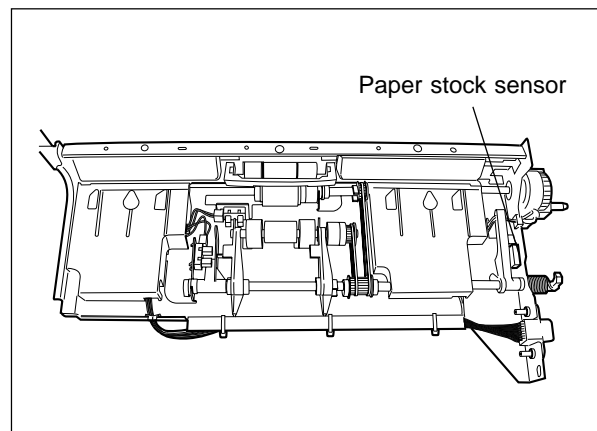

6. PERIODIC MAINTENANCE

Symbols used in the checklist

Cleaning	Coating	Replacing	Date
A: Cleaning with alcohol	W: White grease (Molycoat) AV: Alvania No. 2	81 Every 81K copies △ Replace if deformed or damaged	User's name
			Serial No
			Inspector's name
			Remarks

General Maintenance Checklist

Item to inspect	Cleaning	Coating 1K copies	Replace every	Remarks
Pickup roller(Upper/Lower)	A		81△	
Feed roller(Upper/Lower)	A		81△	
Separation roller(Upper/Lower)	A	AV	81△	Note)
Drive gears(tooth face)		W		

*The above parts are to be replaced depending on the number of the sheets of paper used in each cassette.

Note: Apply the appropriate amount of the grease as specified in the right figure.

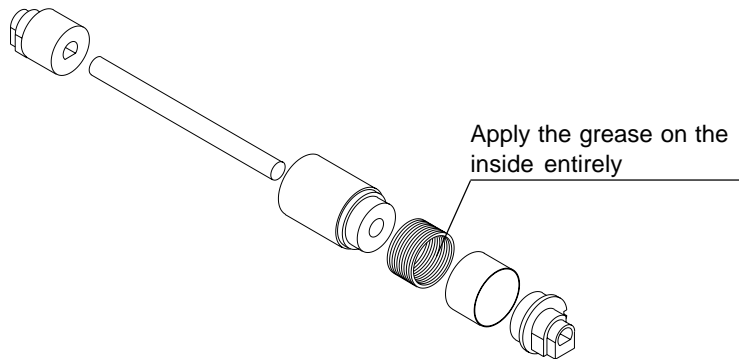

MEMO

MEMO

MEMO