

TOSHIBA

SERVICE PARTS LIST

LARGE CAPACITY FEEDER

KD-1010

P

EXPLANATION OF SERVICE-PARTS LIST

1. HOW TO READ THE PARTS LIST

- (1) **Number of pieces**
The number of pieces in the list denotes total pieces used per unit. But the numbers in the list for **PACKING MATERIAL** and **ACCESSORY** denote total pieces used per machine.
- (2) One pack of screws in the list includes 50 pieces.
- (3) **ABBREVIATED CODES**

QTY/PAC	QTY	one piece
	PAC	one pack
	1/P	one piece packed in polyethylene bag
	1/S	one piece packed in special pack
	1/C	one piece packed in carton box
	1/PP	one piece packed in paper and polyethylene bag
	1/KP	one piece packed in polyethylene bag with cardboard
	1/D	one piece packed in polyethylene-cushion bag
	1/SB	one piece packed in shielding bag
N/A	not available	

P	PURPOSE
	A	ADD
	B	DELETE
	C	CHANGE
	D	QTY. CHANGE
	E	MISENTRY
F	OMISSION	

I INTERCHANGEABILITY STATUS

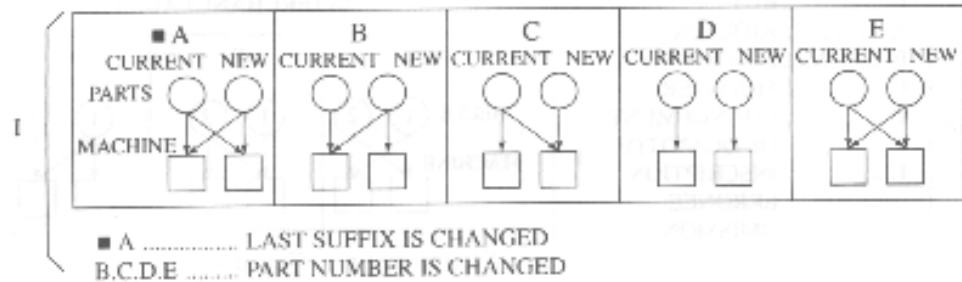

2. HOW TO PLACE ORDER FOR PARTS

- (1) The parts handled as service parts are only those with their "QTY/PACK" column listed with a quantity other than "N/A***" or "SUPPLY".
Those parts with "N/A***" are listed only for the purpose of showing the mechanical construction, those listed with "SUPPLY" are handled only as a sales item, and therefore both types of parts are not supplied as service parts.
- (2) Orders for any parts which form a component of a semi-assembled unit are not acceptable.
Note: All the screws and nuts used are ISO standard.

NOTICE EXPLICATIVE DE LA LISTE DES PIÈCES DE RECHANGE

I. COMMENT UTILISER LA LISTE DES PIÈCES DE RECHANGE

- (1) Nombre de pièces
Le nombre de pièces indiqué sur la liste est le nombre total de pièces utilisées pour chaque unité.
Toutefois, le nombre indiqué sur la liste EMBALLAGE ACCESSOIRES est le nombre total de pièces utilisées pour chaque machine.
- (2) Un paquet de vis indiqué sur la liste contient 50 vis.
- (3) ABBREVIATIONS

QTY/PAC	{	QTY	une pièce
		PAC	un paquet
		1/P	une pièce emballée dans un sac en polyéthylène
		1/S	une pièce emballée dans un sac spécial
		1/C	une pièce emballée dans une boîte en carton
		1/PP	une pièce emballée dans un sac en papier et en polyéthylène
		1/KP	une pièce emballée dans un sac en polyéthylène avec carton
		1/D	une pièce emballée dans un sac rembourré en polyéthylène
1/SB	une pièce emballée dans		
N/A***	non disponible		

P	{	P	BUT
		A	AJOUTER
		B	SUPPRIMER
		C	MODIFIER
		D	CHANGEMENT DE QUANTITE
		E	INSCRIPTION ERRONEE
		F	OMISSION

I INTERCHANGEABILITE

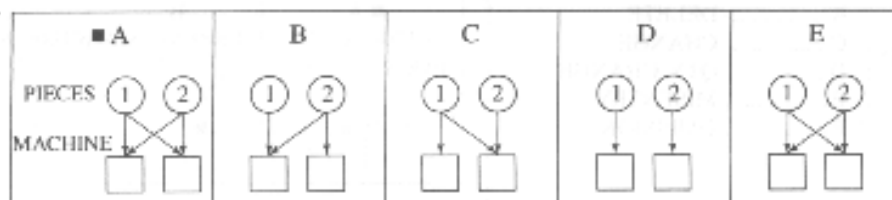

① ACTUELLE ② NOUVELLE
 ■ A LE DERNIER SUFFIXE EST CHANGE
 B.C.D.E LE NOMBRE DE PIÈCES EST CHANGE

2. COMMENT COMMANDER LES PIÈCES

- (1) Les pièces de rechange sont uniquement celles qui sont mentionnées dans la colonne "QTY/PACK" avec une quantité autre que "N/A***" ou "SUPPLY".
Les pièces dans la colonne "N/A***" sont mentionnées uniquement dans le but d'indiquer la construction mécanique. Les pièces dans la colonne "SUPPLY" sont destinées uniquement à la vente. Par conséquent, ces deux types de pièces ne sont pas fournies en tant que pièces de rechange.
- (2) Les commandes de toute pièce formant un élément ou une unité semi-assemblée ne seront pas acceptées.
Nota: Toutes les vis et tous les écrous seront conformes au code ISO.

ERKLÄRUNG DES ERSATZTEIL-KATALOGES

1. WIE LIEST MAN DIE TEILELISTE?

- (1) Die Teileanzahl
Die Anzahl der Teile in der Liste, drücken die gesamten Teile pro Verpackungseinheit aus. Aber die Zahl in der Liste "Packing" (Verpackung) und "Accessory" (Zubehör) beschreibt die gesamte Teileanzahl pro Maschine.
- (2) Eine Verpackungseinheit SCHRAUBEN enthält 50 Stück.
- (3) Abkürzungscode

QTY/PAC	QTY	Stück
	PAC	Packung
	1/P	ein Stück in einem Plastikbeutel
	1/S	ein Stück in einer Spezialverpackung
	1/C	ein Stück in einem Karton
	1/PP	ein Stück in Papier und einem Plastikbeutel
	1/KP	ein Stück in einem Plastikbeutel mit Pappdeckel
	1/D	ein Stück in einem gepolsterten Plastikbeutel
	N/A	nicht lieferbar
1/SB	ein Stück in einer Schutzhülle	

P	P	Zweck
	A	Zusätzlich
	B	Entfernen
	C	Ändern
	D	Menge geändert
	E	Fehlangebe
F	Weglassen	

I Austauschbar untereinander

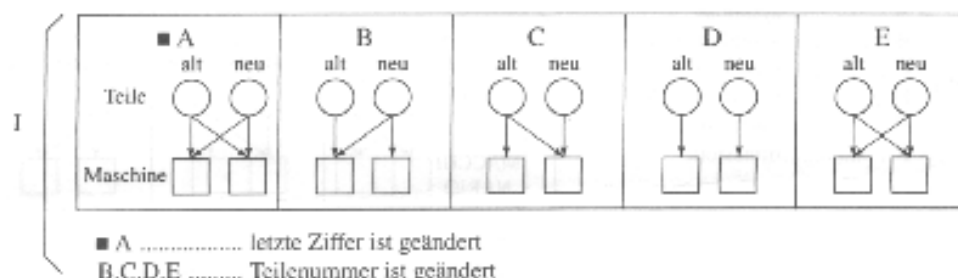

2. WIE WERDEN ERSATZTEILE BESTELLT?

- (1) Die Ersatzteile für den Service haben in der Spalte "QTY/PACK" eine Nummer.
Die Teile mit der Angabe "N/A***" sind nur aufgeführt, um die technische Konstruktion zu zeigen und sind einzeln nicht lieferbar.
Die Bezeichnung "SUPPLY" weist darauf hin, daß dieses Teil als Zubehör gehandelt wird und beim Verkauf bestellt werden muß.
- (2) Bestellungen für Einzelteile, die einer Baueinheit angehören können nicht akzeptiert werden.
Hinweis: Alle Schrauben und Muttern werden nach dem ISO-Standard hergestellt.

SPIEGAZIONE DELLA LISTA DEI PEZZI DI RICAMBIO

1. COME LEGGERE LA LISTA DEI PEZZI DI RICAMBIO

- (1) Numero dei pezzi
Il numero dei pezzi indica il totale dei pezzi per elemento. I numeri nella lista del materiale d'imballaggio e accessori indicano il totale dei pezzi per macchina.
- (2) Nella lista, un pacco di viti contiene 50 viti.
- (3) ABBREVIAZIONI

QTY/PAC	{	QTY	un pezzo
		PAC	un pacco
		I/P	un pezzo imballato in sacco di polietilene
		I/S	un pezzo imballato in pacco speciale
		I/C	un pezzo imballato in scatola di cartone
		I/PP	un pezzo imballato in sacco di polietilene e carta
		I/KP	un pezzo imballato in sacco di polietilene con cartone
		I/D	un pezzo imballato in sacco morbido di polietilene
I/SB	un pezzo imballato in sacco di protezione		
N/A	non disponibile		

P	{	P	scopo
		A	aggiunta
		B	annullamento
		C	modifica
		D	modifica QTY
		E	ingresso errato
F	omissione		

I stato di intercambiabilità

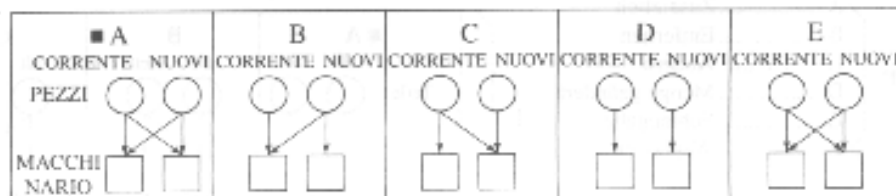

■ A modifica dell'ultimo suffisso
B.C.D.E modifica del numero di pezzo

2. ORDINAZIONE DEI PEZZI

- (1) I pezzi usati come pezzi di ricambio sono elencati nella colonna "QTY/PACK" con una quantità differente da "N/A****" o "SUPPLY".
I pezzi con "N/A****" sono elencati solamente per mostrare la costruzione meccanica e quelli con "SUPPLY" sono elencati solamente come articoli di vendita; ciò significa che questi due tipi di pezzi non sono forniti come pezzi di ricambio.
- (2) L'ordinazione dei pezzi non viene accettata quando questi pezzi formano un componente di un messo elemento.
Nota: Tuttle le viti e i dadi sono standard ISO.

EXPLICACION DE LA LISTA DE PIEZAS DE SERVICIO

1. Cómo se lee la lista de piezas

- (1) El número de piezas
El número de piezas en la lista especifica las piezas totales usada por unidad, mientras que el número en la lista para MATERIAL DE EMBALAJE y ACCESORIOS especifica las piezas totales usadas por máquina.
- (2) En el paquete de tornillos se incluyen 50 unidades.
- (3) Códigos abreviados

QTY/PAC	QTY	una pieza
	PAC	una paquete
	1/P	una pieza empaquetada en la bolsa de politileno
	1/S	una pieza empaquetada en paquete especial
	1/C	una pieza empaquetada en caja de cartón
	1/PP	una pieza empaquetada en papel y bolsa de politileno
	1/KP	una pieza empaquetada en bolsa de politileno con cartón
	1/D	una pieza empaquetada en bolsa almohadillada de politileno
1/SB	una pieza empaquetada en una	
N/A	bolsa protegida	

P	P	PROPOSITO
	A	AÑADIR
	B	BORRAR
	C	CAMBIO
	D	CANTIDAD, CAMBIO
	E	ENTRADA ERRONEA
	F	OMISION

I SITUACION DE INTERCAMBIABILIDAD

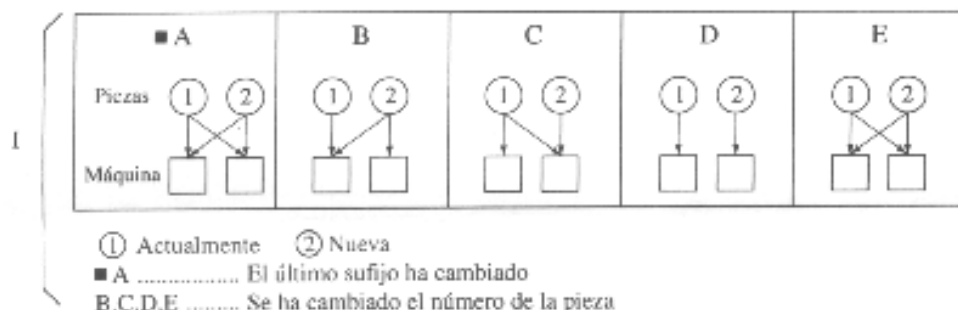

2. Cómo realizar un pedido de piezas

- (1) Las piezas consideradas como piezas de servicio son sólo aquellas designadas con QTY/PACK y no las designadas con N/A ... o SUPPLY.
Aquellas piezas con N/A ... se ponen en lista sólo con el propósito de mostrar la construcción mecánica. Aquellas piezas designadas bajo SUPPLY se consideran sólo como un artículo para ventas y por lo tanto ambos tipos de piezas no se consideran como piezas de servicio.
- (2) Los pedidos para cualquier pieza que forme un componente de la unidad semiensamblada no será aceptados.
NOTA: todos los tornillos y tuercas son del estandar ISO.

CONTENTS

1. COVER
 2. FRAME
 3. DRIVE
 4. FEEDER/TRANSPORT 1
 5. FEEDER/TRANSPORT 2
 6. CASSETTE 1
 7. CASSETTE 2
 8. CASSETTE 3/TRAY
-

PARTS NUMBER INDEX

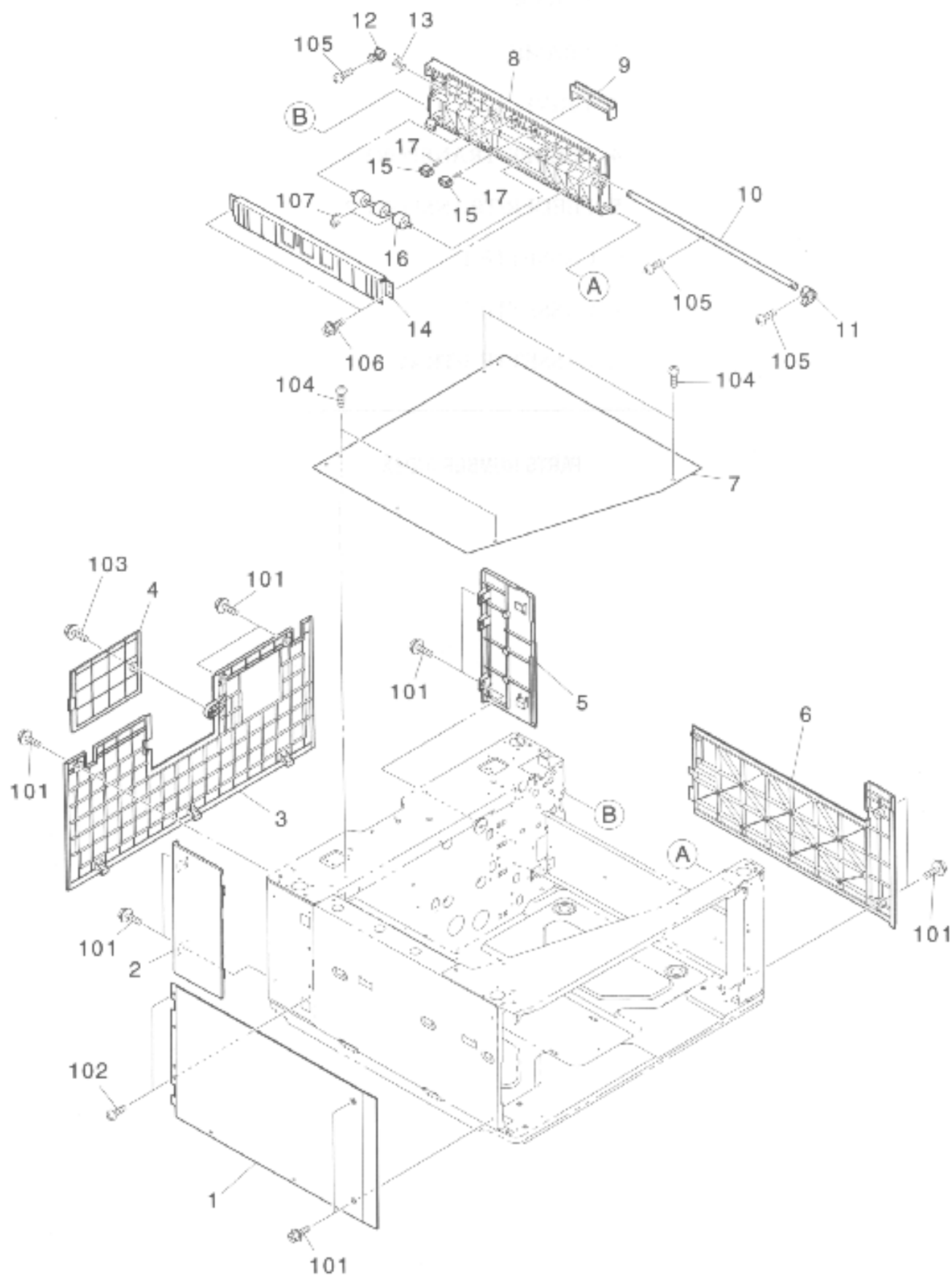

ITEM NO.	PARTS NO.	PARTS NAME	QTY / PAGE	QTY / PACK	P	I	R	BSI NO.	TO	FROM	SERIAL NO.	REMARKS
1	41319542000	COVER-LEFT-F	1	1/P								
2	41319612000	COVER-LEFT-R	1	1/P								
3	41319615000	COVER-REAR	1	1/P								
4	41319645000	COVER-R-1/F	1	1/P								
5	41319614000	COVER-RIGHT-R	1	1/P								
6	41319613000	COVER-RIGHT-F	1	1/P								
7	41319526000	BRKT-COVER-TOP	1	1/P								
8	41319633000	COV-FEED-OPEN	1	1/P								
9	41319634000	HANDLE-COV-OPEN	1	1/P								
10	41319662000	SHAFT-LOCK	1	1/P								
11	41319635000	FOOK-LEVER-F	1	1/P								
12	41319636000	FOOK-LEVER-R	1	1/P								
13	41319692000	SP-LEVER-OPEN	1	5/P								
14	41319578000	BRKT-GUIDE-FEED	1	1/P								
15	41319646000	BUSH-PRESS-4	2	5/P								
16	41319681000	ROLLER-FEED	1	1/P								
17	41319691000	SPC045-060-0133	2	5/P								
101	41319952000	TPHEX30*08-S-P	1	10/P								
102	41319959000	TBID30*08-GLD	2	10/P								
103	41319956000	TPHEX30*10-S-M	1	10/P								
104	41319671000	SCREW-M3*6R	5	10/P								
105	41319961000	BID30*06-GLD	3	10/P								
106	41319955000	TPHEX30*10-G-M	2	10/P								
107	41319964000	ERR030-BLK	2	10/P								

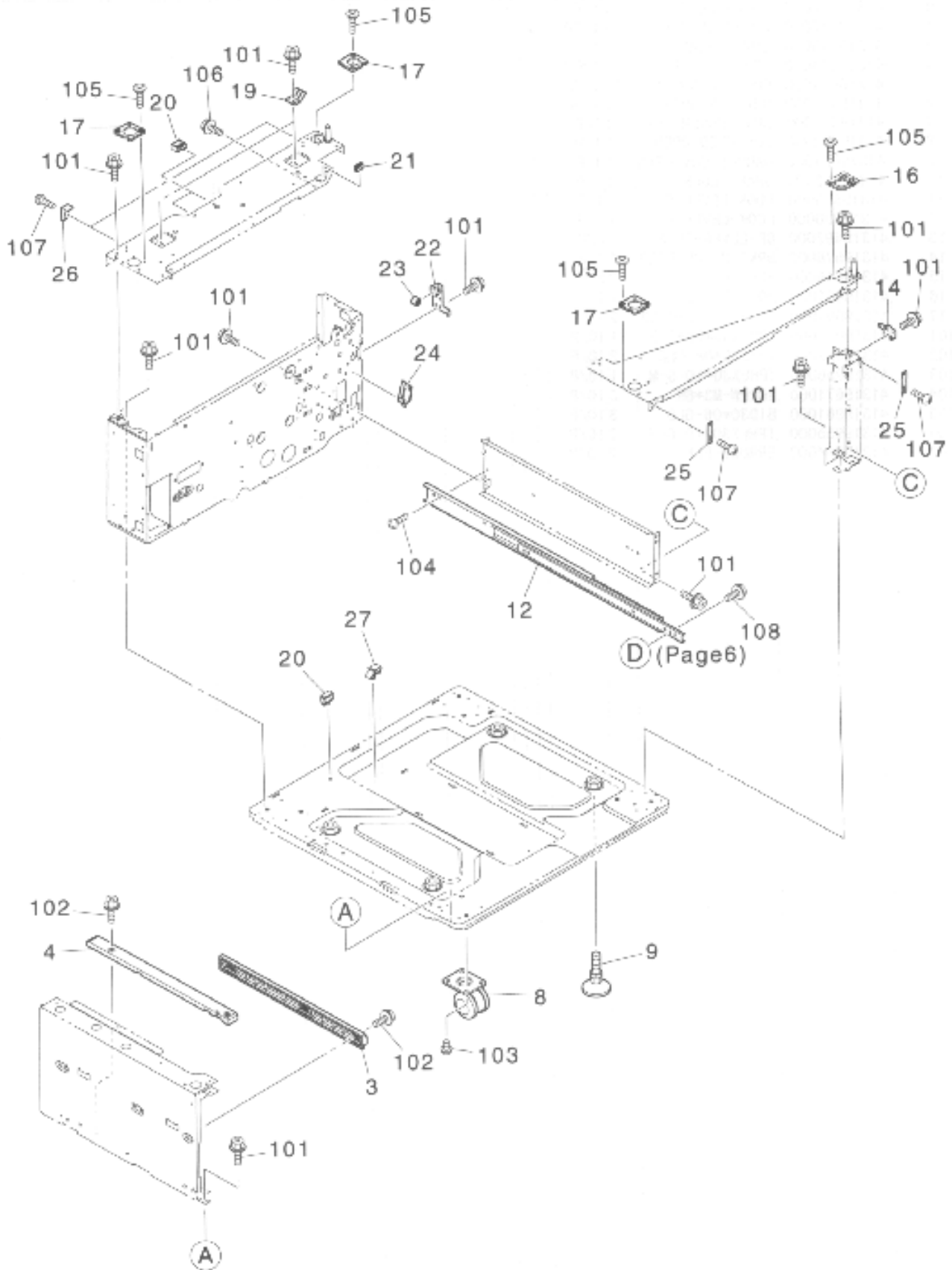

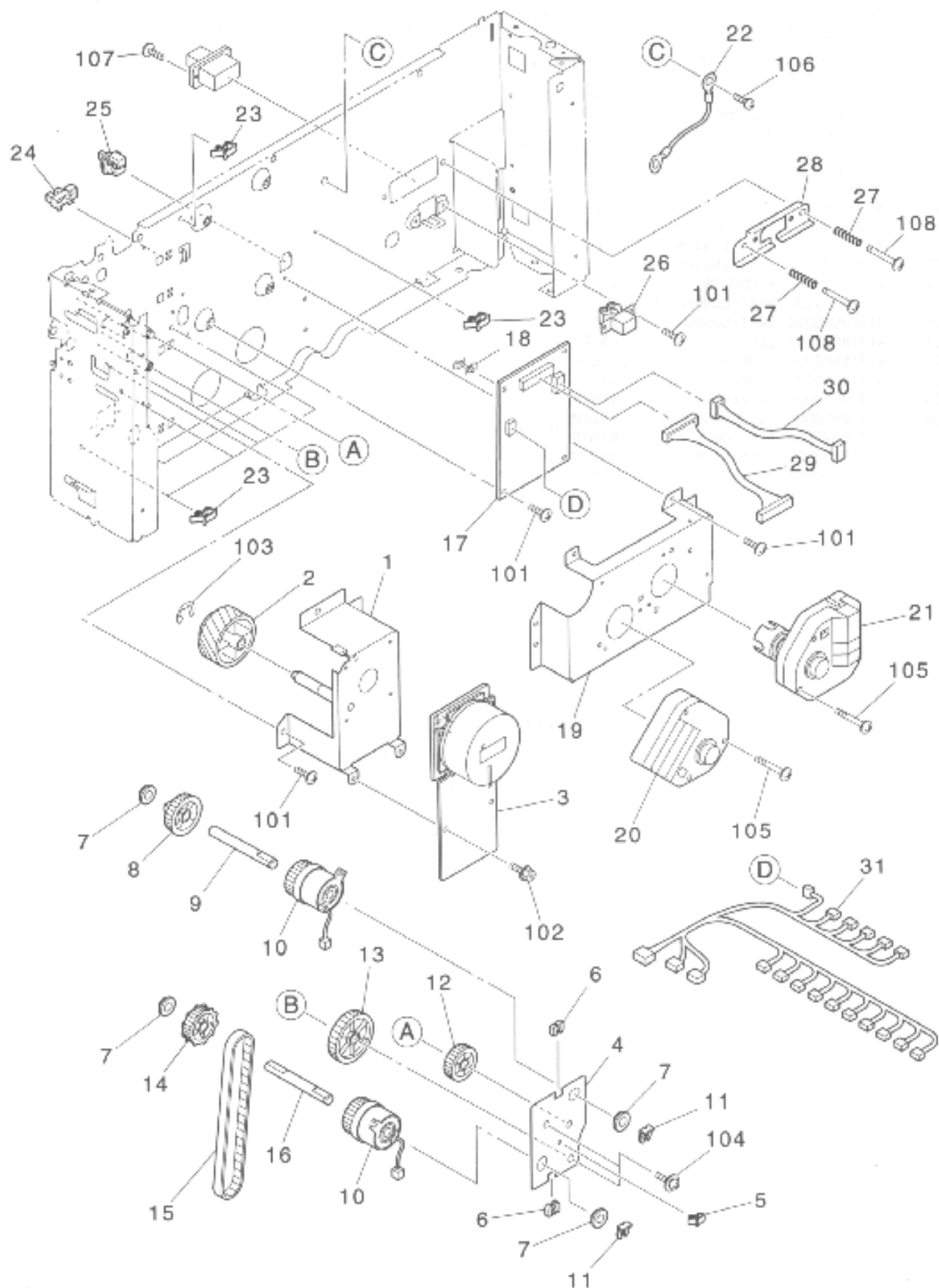

ITEM NO.	PARTS NO.	PARTS NAME	QTY / PAGE	QTY / PACK	P	R	BSI NO.	TO	FROM	SERIAL NO.	REMARKS
1	41319582000	K-BRKT-MOT-LCF	1	1/P							
2	41319637000	GEAR-MOT-27Z	1	1/P							
3	41319905000	M/DC-DRIVE-LCF	1	1/C							
4	41319586000	BRKT-DRIVE-LCF	1	1/P							
5	41319937000	CLP-H-1	1	5/P							
6	41319603000	CLP-ES-0505	2	5/P							
7	41319925000	BUSH-B-DRV	4	5/P							
8	41319639000	GEAR-IDLER-31Z	1	1/P							
9	41319683000	SHAFT-CLT-FEED	1	1/P							
10	41319914000	MAGNETIC-CLT	2	1/C							
11	41319605000	STOP-RING-6	2	10/P							
12	41319638000	GEAR-IDLER-27Z	1	1/P							
13	41319644000	GEAR-IDLER-41Z	1	1/P							
14	41319641000	PLY/T-DRIVE-31T	1	1/P							
15	41319699000	BLT/T-S3M258	1	1/P							
16	41319684000	SHAFT-CLT-FED-T	1	1/P							
17	41319701000	PWA-LCF	1	1/SB							
18	41319935000	CLP-4.8	1	5/P							
19	41319587000	BRKT-MOT-TAN	1	1/P							
20	41319906000	M/DC-TRAY-UP	1	1/C							
21	41319907000	M/DC-SLIDER	1	1/C							
22	41319758000	WH-EARTH	1	1/P							
23	41319938000	CLP-H-2	6	5/P							
24	41319917000	PHD-EE	2	1/C							
25	41319921000	PUSH-SW-ANGLE	1	1/C							
26	41319933000	HOLDER-TRAY	2	1/P							
27	41319696000	SPC-DRAW	2	1/P							
28	41319538000	BRKT-DRW	1	1/P							
29	41319752000	WH-1/F-LCF	1	1/P							
30	41319753000	WH-PWR-LCF	1	1/P							
31	41319751000	WH-MAIN-LCF	1	1/P							
101	41319673000	SCREW-Z-M3*6	14	10/P							
102	41319951000	TPHEX30*08-G-P	6	10/P							
103	41319966000	ERR060-BLK	1	10/P							
104	41319963000	ZPAN30*06-GLD	2	10/P							
105	41319667000	SCREW-BKT-MOT	6	10/P							
106	41319672000	SCREW-B-M4*8	1	10/P							
107	41319669000	SCREW-CDN	2	10/P							
108	41319666000	SCREW-DRW-CON	2	10/P							

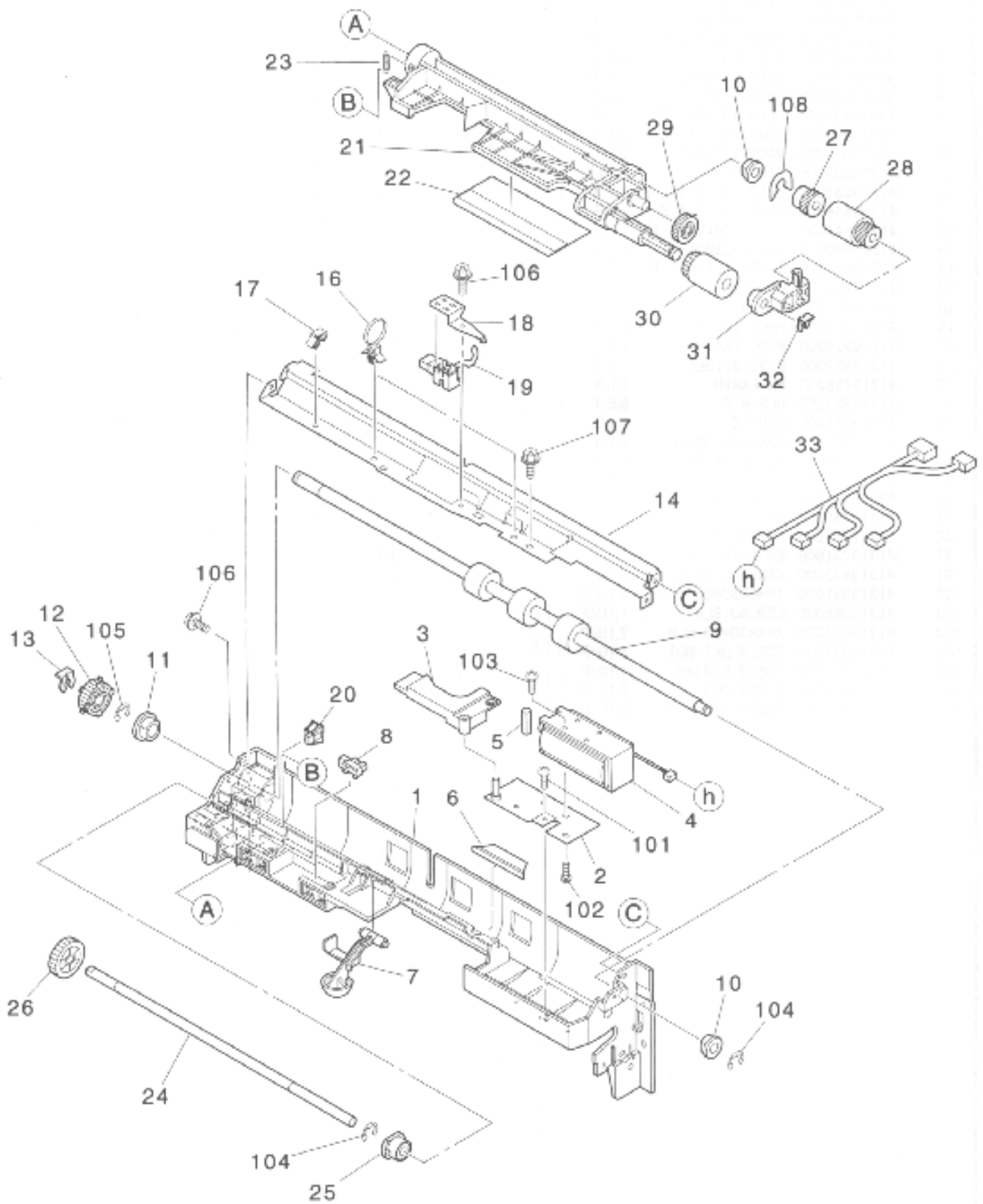

ITEM NO.	PARTS NO.	PARTS NAME	QTY / PAGE	QTY / PACK	P	R	BSI NO.	TO	FROM	SERIAL NO.	REMARKS
1	41319627000	HSG-FEED-LCF	1	1/P							
2	41319574000	K-BKT-PICK-UP	1	1/P							
3	41319631000	LEV-PICK-UP	1	1/P							
4	41319908000	SND-PICK-UP13.7	1	1/C							
5	41319968000	WPIN30/10-BLK	1	10/P							
6	41319923000	MYLAR-GUIDE-FED	1	1/P							
7	41319661000	FEELER-PAPER	1	1/P							
8	41319916000	PHD-H	2	1/C							
9	41319679000	ROLLER-FEED-D	1	1/KP							
10	41319934000	BUSH-6-3	2	5/P							
11	41319926000	BUSH-8-1	1	5/P							
12	41319642000	PLY/T-FEED-24T	1	1/P							
13	41319805000	STOP-RING-6	1	10/P							
14	41319577000	STAY-FEED	1	1/P							
16	41319936000	BAND-SG-130	2	5/P							
17	41319937000	CLP-H-1	1	5/P							
18	41319801000	BRKT-SENSOR	1	1/P							
19	41319918000	PHD-V	1	1/C							
20	41319911000	PUSH-SW	1	1/C							
21	41319628000	ARM-PICK-UP	1	1/P							
22	41319932000	GUIDE-ARM-PICK	1	1/P							
23	41319693000	SPE-PRESS-PICK	1	5/P							
24	41319680000	SHAFT-FEED	1	1/P							
25	41319647000	ROLLER-CLUTCH	1	1/P							
26	41319640000	GEAR-FEED-Z24	1	1/P							
27	41319651000	GEAR-ROL-CLT	1	1/P							
28	41319658000	ROL-PAPER-FED-F	1	1/P							
29	41319650000	GEAR-IDL-PICK	1	1/P							
30	41319632000	ROL-PICK-UP	1	1/P							
31	41319629000	ARM-PICK-UP-SND	1	1/P							
32	41319606000	STOP-RING-SEP	1	5/P							
33	41319756000	WH-FEED-LCF	1	1/P							
101	41319954000	TPHEX30*08-G-M	1	10/P							
102	41319960000	BID30*04-GLD	2	10/P							
103	41319668000	SCREW-SND-M3*3	1	10/P							
104	41319965000	ERRO40-BLK	2	10/P							
105	41319966000	ERRO80-BLK	1	10/P							
106	41319951000	TPHEX30*08-G-P	5	10/P							
107	41319955000	TPHEX30*10-G-M	2	10/P							
108	41319602000	ERR-SILENCER	1	10/P							

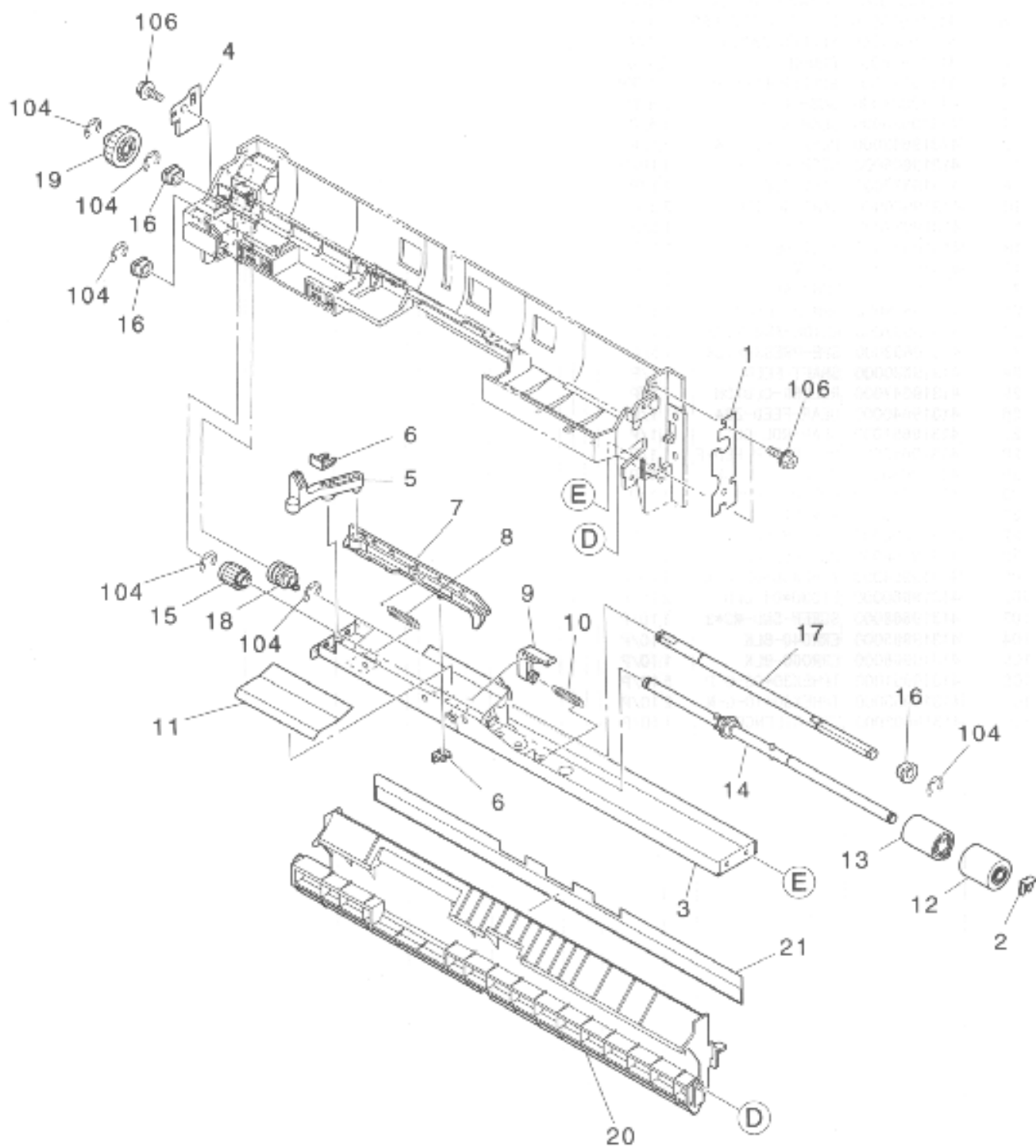

ITEM NO.	PARTS NO.	PARTS NAME	QTY	QTY	PIR	BSI NO.	TO	FROM	SERIAL NO.	REMARKS
			PAGE	PACK						
1	41319573000	SPL-EARTH-FED-F	1	1						
2	41319606000	STOP-RING-SEP	1	5						
3	41319591000	ASM-STAY-SEP	1	1						
4	41319600000	SPL-EARTH	1	1						
5	41319664000	LEVER-PRESSURE	1	1						
6	41319604000	STOP-RING-3	2	5						
7	41319663000	LINK-RELEASE	1	1						
8	41319694000	SPE-RELEASE	1	5						
9	41319662000	LEV-PRESS-SEP	1	1						
10	41319695000	SPE-PRESS-SEP	1	5						
11	41319928000	GUIDE-SEP-BACK	1	1						
12	41319660000	ROL-PAPER-FED-S	1	1						
13	41319665000	TORQUE-LIMITER	1	1						
14	41319688000	ASM-SFT-S-DRV-2	1	1						
15	41319649000	GEAR-SEP-DRV-2	1	1						
16	41319927000	BUSH-6-2	3	5						
17	41319685000	SFT-SEP-DRV-1	1	1						
18	41319648000	GEAR-SEP-DRV-1	1	1						
19	41319652000	GEAR-SEP-INPUT	1	1						
20	41319630000	GUIDE-FEED-OPEN	1	1						
21	41319929000	GUIDE-V	1	1						
104	41319965000	ERR040-BLK	6	10						
106	41319951000	TPHEX30*08-G-P	4	10						

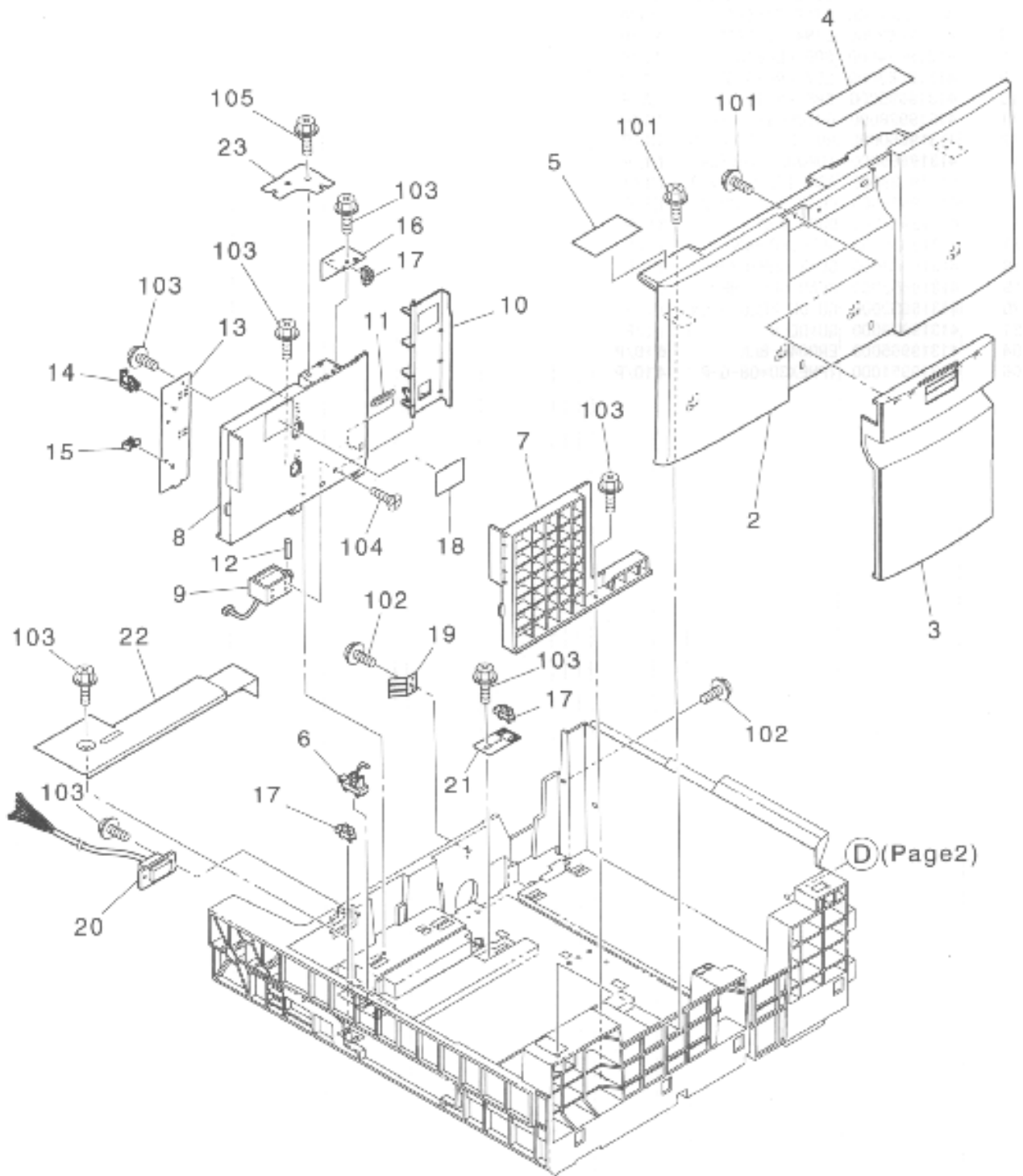

(D) (Page 2)

ITEM NO.	PARTS NO.	PARTS NAME	Q'TY / PAGE	Q' TY / PACK	PIR	BSI NO.	TO	FROM	SERIAL NO.	REMARKS
2	41319617000	COVER-FRONT	1	1/PP						
3	41319618000	COVER-HANDLE-F	1	1/PP						
4	41319971000	LBL-P-SET	1	5/P						
5	41319972000	LBL-TRAY-SET-F	1	5/P						
6	41319919000	PHD-ACT	1	1/C						
7	41319619000	FENCE-SIDE-L-F	1	1/P						
8	41319620000	FENCE-SIDE-L-R	1	1/P						
9	41319912000	DCSOL-24V	1	1/C						
10	41319621000	LEVER-TRAY-S	1	1/P						
11	41319690000	SPE030-035-017B	1	5/P						
12	41319966000	WPIN30/10-BLK	1	10/P						
13	41319543000	BRKT-P-G-L	1	1/P						
14	41319939000	CLP-LWS-1S	1	5/P						
15	41319937000	CLP-H-1	1	5/P						
16	41319544000	BRKT-LEVER-TOP	1	1/P						
17	41319917000	PHD-EE	3	1/C						
18	41319973000	LBL-P-LIMIT	1	5/P						
19	41319523000	SPL-EARTH-LCF	1	1/P						
20	41319755000	WH-TRAY-CONNECT	1	1/P						
21	41319553000	BRKT-P-SIZE-SZ	1	1/P						
22	41319548000	BRKT-COV-P-END	1	1/P						
23	41319979000	BKT-FENCE-STOP	1	1/P						
101	41319957000	TPHEX30*12-G-M	4	10/P						
102	41319951000	TPHEX30*08-G-P	2	10/P						
103	41319955000	TPHEX30*10-G-M	7	10/P						
104	41319947000	FLT30*06	2	10/P						
105	41319980000	SCREW-P-M3*10.3	1	10/P						

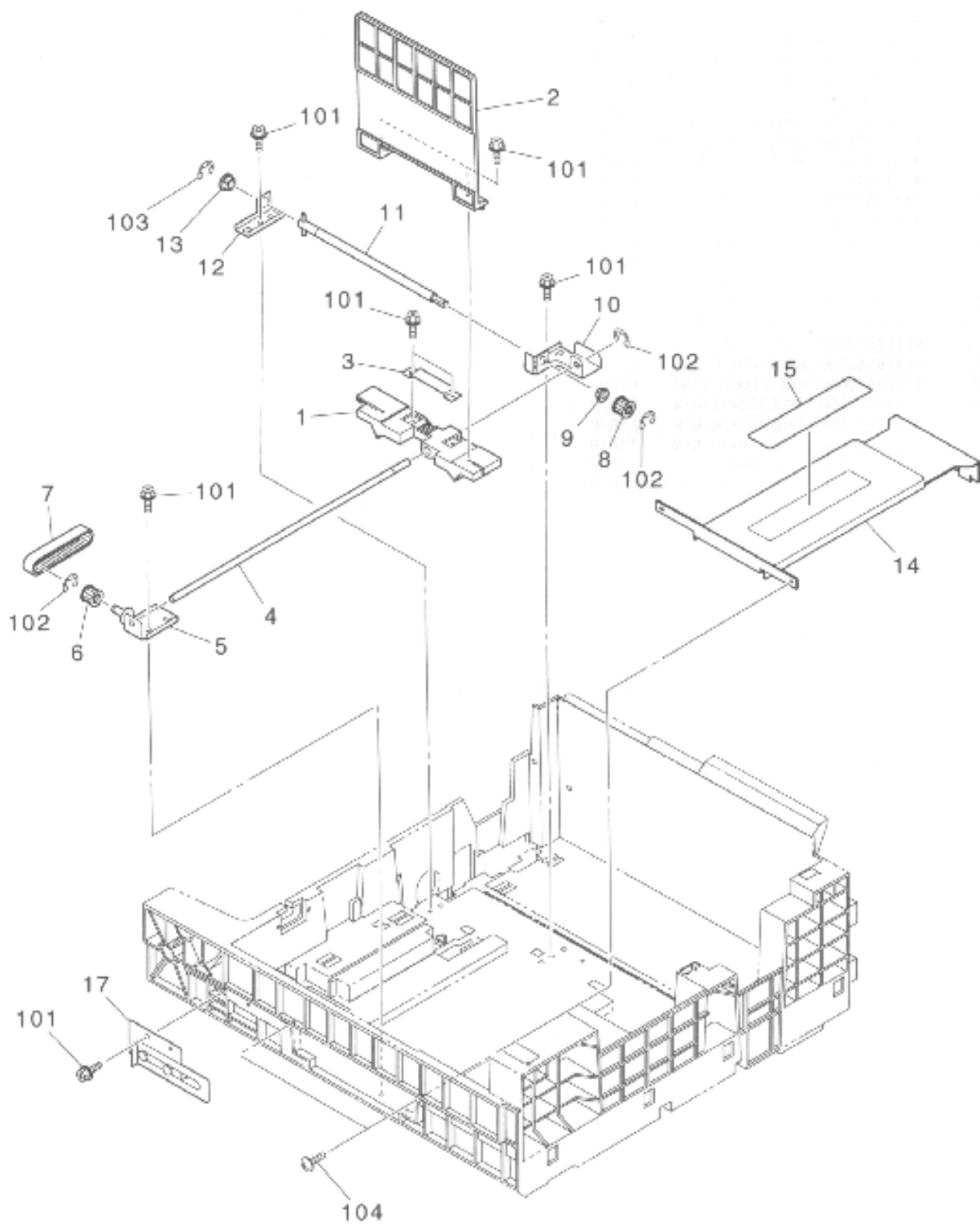

ITEM NO.	PARTS NO.	PARTS NAME	QTY / PAGE	TY / PACK	P	I	R	BSI NO.	TO	FROM	SERIAL NO.	REMARKS
1	41319554000	K-GUIDE-SIDE-RF	11/P									
2	41319568000	BRKT-DAMPER	11/P									
3	41319931000	OIL-DAMPER	11/P									
4	41319567000	BRKT-BELT-STOP	21/P									
5	41319653000	GEAR-DUMP-Z18	11/P									
6	41319654000	PLY-BRKT	21/P									
7	41319941000	BUSHB-2	215/P									
8	41319969000	WPIN30/14-BLK	210/P									
9	41319698000	BLT/T-B80S3M426	21/P									
10	41319626000	PLY/T-3-020	21/P									
11	41319566000	BRKT-ROL-STOP	21/P									
12	41319625000	PLY-TRAY-ROL	41/P									
13	41319624000	TRAY-TAN-LCF	11/P									
14	41319589000	PLT-BALANCER	11/P									
15	41319930000	PAD-PLATE	115/P									
16	41319975000	LBL-P-SET-TRY-R	11/KP									
17	41319559000	K-FENCE-SIDE-RF	11/P									
18	41319562000	K-FENCE-SIDE-RR	11/P									
19	41319973000	LBL-P-LIMIT	15/P									
20	41319556000	K-GUIDE-SIDE-RR	11/P									
21	41319677000	ASM-SFT-TRAY	11/P									
101	41319955000	TPHEX30*10-G-M	1210/P									
102	41319951000	TPHEX30*08-G-P	210/P									
103	41319953000	TPHEX40*08-G-P	210/P									
104	41319949000	TPHEX30*06-G-P	210/P									
105	41319986000	ERR060-BLK	410/P									

PARTS NUMBER INDEX

PARTS NO.	PARTS NAME	QTY		PAGE	ITEM NO.	PIR	B S I NO.	SERIAL NO.	REMARKS	LOCATION	C
		PAGE	PACK								
41319523000	SPL-EARTH-LCF	21/P		2	19						
		11/P		6	19						
41319526000	BRKT-COVER-TOP	11/P		1	7						
41319538000	BRKT-DRW	11/P		3	28						
41319542000	COVER-LEFT-F	11/PP		1	1						
41319543000	BRKT-P-G-L	11/P		6	13						
41319544000	BRKT-LEVER-TOP	11/P		6	16						
41319545000	BRKT-STOP-BELT	11/P		7	3						
41319546000	BRKT-COV-P-END	11/P		6	22						
41319547000	BRKT-COV-BELT	11/P		7	14						
41319548000	BRKT-SLIDER-D1	11/P		7	12						
41319549000	BRKT-SLIDER-D2	11/P		7	10						
41319550000	K-BKT-SLIDER-D3	11/P		7	5						
41319553000	BRKT-P-SIZE-SZ	11/P		6	21						
41319554000	K-GUIDE-SIDE-RF	11/P		8	1						
41319558000	K-GUIDE-SIDE-RR	11/P		8	20						
41319559000	K-FENCE-SIDE-RF	11/P		8	17						
41319562000	K-FENCE-SIDE-RR	11/P		8	18						
41319566000	BRKT-ROL-STOP	21/P		8	11						
41319567000	BRKT-BELT-STOP	21/P		8	4						
41319568000	BRKT-DAMPER	11/P		8	2						
41319569000	K-BKT-TRAY-STOP	11/P		7	17						
41319573000	SPL-EARTH-FED-F	11/P		5	1						
41319574000	K-BKT-PICK-UP	11/P		4	2						
41319577000	STAY-FEED	11/P		4	14						
41319578000	BRKT-GUIDE-FEED	11/P		1	14						
41319579000	K-BRKT-LOCK-F	11/P		2	14						
41319582000	K-BRKT-MOT-LCF	11/P		3	1						
41319585000	SPL-TENSION	11/P		2	22						
41319586000	BRKT-DRIVE-LCF	11/P		3	4						
41319587000	BRKT-MOT-TAN	11/P		3	19						
41319589000	BRKT-CONNECT-F	21/P		2	25						
41319590000	BRKT-CONNECT-R	21/P		2	26						
41319591000	ASM-STAY-SEP	11/P		5	3						
41319599000	PLT-BALANCER	11/P		8	14						
41319600000	SPL-EARTH	11/P		5	4						
41319601000	BRKT-SENSOR	11/P		4	18						
41319602000	ERR-SILENCER	110/P		4	108						
41319603000	CLP-ES-0505	25/P		3	6						
41319604000	STOP-RING-3	25/P		5	6						
41319605000	STOP-RING-6	210/P		3	11						
		110/P		4	13						
41319606000	STOP-RING-SEP	15/P		4	32						
		15/P		5	2						
41319607000	SPACER-TOP-F-R	11/P		2	16						
41319608000	SPACER-TOP-LCF	31/P		2	17						
41319609000	RAIL-TOP-L	11/P		2	3						
41319610000	RAIL-LOW-L	11/P		2	4						
41319611000	SLIDER-RAIL	11/P		2	12						
41319612000	COVER-LEFT-R	11/PP		1	2						
41319613000	COVER-RIGHT-F	11/PP		1	6						
41319614000	COVER-RIGHT-R	11/PP		1	5						
41319615000	COVER-REAR	11/PP		1	3						
41319617000	COVER-FRONT	11/PP		6	2						
41319618000	COVER-HANDLE-F	11/PP		6	3						
41319619000	FENCE-SIDE-L-F	11/P		6	7						
41319620000	FENCE-SIDE-L-R	11/P		6	8						
41319621000	LEVER-TRAY-S	11/P		6	10						
41319622000	FENCE-E-TRAY	11/P		7	2						
41319623000	SLIDER-E-FENCE	11/P		7	1						
41319624000	TRAY-TAN-LCF	11/P		8	13						
41319625000	PLY-TRAY-ROL	41/P		8	12						
41319626000	PLY/T-3-020	21/P		8	10						
41319627000	HSG-FEED-LCF	11/P		4	1						
41319628000	ARM-PICK-UP	11/P		4	21						
41319629000	ARM-PICK-UP-SND	11/P		4	31						
41319630000	GUIDE-FEED-OPEN	11/P		5	20						
41319631000	LEV-PICK-UP	11/P		4	3						
41319632000	ROL-PICK-UP	11/P		4	30						
41319633000	COV-FEED-OPEN	11/P		1	8						

MSP

PARTS NO.	PARTS NAME	QTY	QTY	PAGE	ITEM NO.	PIR	B S I NO.	SERIAL NO.	REMARKS	LOCATION
		PAGE	PACK							
41319634000	HANDLE-COV-OPEN	1	1/P	1	9					
41319635000	FOOK-LEVER-F	1	1/P	1	11					
41319636000	FOOK-LEVER-R	1	1/P	1	12					
41319637000	GEAR-MOT-27Z	1	1/P	3	2					
41319638000	GEAR-IDLER-27Z	1	1/P	3	12					
41319639000	GEAR-IDLER-31Z	1	1/P	3	8					
41319640000	GEAR-FEED-224	1	1/P	4	26					
41319641000	PLY/T-DRIVE-31T	1	1/P	3	14					
41319642000	PLY/T-FEED-24T	1	1/P	4	12					
41319643000	PLY-TENSION-12	1	1/P	2	23					
41319644000	GEAR-IDLER-41Z	1	1/P	3	13					
41319645000	COVER-R-1/F	1	1/PP	1	4					
41319646000	BUSH-PRESS-4	2	5/P	1	15					
41319647000	ROLLER-CLUTCH	1	1/P	4	25					
41319648000	GEAR-SEP-DRV-1	1	1/P	5	18					
41319649000	GEAR-SEP-DRV-2	1	1/P	5	15					
41319650000	GEAR-IDL-PICK	1	1/P	4	29					
41319651000	GEAR-ROL-CLT	1	1/P	4	27					
41319652000	GEAR-SEP-INPUT	1	1/P	5	19					
41319653000	GEAR-DUMP-Z18	1	1/P	8	5					
41319654000	PLY-BRKT	2	1/P	8	6					
41319655000	PLY-DRIVE-1	1	1/P	7	8					
41319656000	PLY-DRIVE-2	1	1/P	7	6					
41319658000	ROL-PAPER-FED-F	1	1/P	4	28					
41319659000	CASTER-LCF	4	1/P	2	8					
41319660000	ROL-PAPER-FED-S	1	1/P	5	12					
41319661000	FEELER-PAPER	1	1/P	4	7					
41319662000	LEV-PRESS-SEP	1	1/P	5	9					
41319663000	LINK-RELEASE	1	1/P	5	7					
41319664000	LEVER-PRESSURE	1	1/P	5	5					
41319665000	TORQUE-LIMITER	1	1/P	5	13					
41319666000	SCREW-DRW-CON	2	10/P	3	108					
41319667000	SCREW-BKT-MOT	6	10/P	3	105					
41319668000	SCREW-SND-M3*3	1	10/P	4	103					
41319669000	SCREW-CON	2	10/P	3	107					
41319670000	SCREW-M5*6	8	10/P	2	103					
41319671000	SCREW-M3*6R	5	10/P	1	104					
41319672000	SCREW-B-M4*8	1	10/P	3	106					
41319673000	SCREW-Z-M3*6	3	10/P	2	106					
		14	10/P	3	101					
41319674000	ASM-SFT-SLID-D	1	1/P	7	11					
41319676000	SFT-FENCE-E	1	1/P	7	4					
41319677000	ASM-SFT-TRAY	1	1/P	8	21					
41319679000	ROLLER-FEED-D	1	1/KP	4	9					
41319680000	SHAFT-FEED	1	1/P	4	24					
41319681000	ROLLER-FEED	1	1/P	1	16					
41319682000	SHAFT-LOCK	1	1/P	1	10					
41319683000	SHAFT-CLT-FEED	1	1/P	3	9					
41319684000	SHAFT-CLT-FED-T	1	1/P	3	16					
41319685000	SFT-SEP-DRV-1	1	1/P	5	17					
41319688000	ASM-SFT-S-DRV-2	1	1/P	5	14					
41319690000	SPE030-035-0178	1	5/P	6	11					
41319691000	SPC045-060-0133	2	5/P	1	17					
41319692000	SP-LEVER-OPEN	1	5/P	1	13					
41319693000	SPE-PRESS-PICK	1	5/P	4	23					
41319694000	SPE-RELEASE	1	5/P	5	8					
41319695000	SPE-PRESS-SEP	1	5/P	5	10					
41319696000	SPC-DRAW	2	1/P	3	27					
41319697000	BLT/T-S3M588	1	1/P	7	7					
41319698000	BLT/T-B80S3M426	2	1/P	8	9					
41319699000	BLT/T-S3M258	1	1/P	3	15					
41319701000	PWA-LCF	1	1/SB	3	17					
41319751000	WH-MAIN-LCF	1	1/P	3	31					
41319752000	WH-1/F-LCF	1	1/P	3	29					
41319753000	WH-PWR-LCF	1	1/P	3	30					
41319755000	WH-TRAY-CONNECT	1	1/P	6	20					
41319756000	WH-FEED-LCF	1	1/P	4	33					
41319758000	WH-EARTH	1	1/P	3	22					
41319905000	M/DC-DRIVE-LCF	1	1/C	3	3					
41319906000	M/DC-TRAY-UP	1	1/C	3	20					

PARTS NO.	PARTS NAME	Q'TY	Q'TY	PAGE	ITEM NO.	PIR	B S I NO.	SERIAL NO.	REMARKS	LOCATION	C
		PAGE	PACK								
41319907000	M/DC-SLIDER	11/G		3	21						
41319908000	SND-PICK-UP13.7	11/G		4	4						
41319911000	PUSH-SW	11/G		4	20						
41319912000	DCSOL-24V	11/G		6	9						
41319914000	MAGNETIC-CLT	21/G		3	10						
41319916000	PHD-H	21/G		4	8						
41319917000	PHD-EE	21/G		3	24						
		31/G		6	17						
41319918000	PHD-V	11/G		4	19						
41319919000	PHD-ACT	11/G		6	6						
41319921000	PUSH-SW-ANGLE	11/G		3	25						
41319922000	MICRO-SW	11/G		2	24						
41319923000	MYLAR-GUIDE-FED	11/P		4	6						
41319925000	BUSH-B-DRV	45/P		3	7						
41319926000	BUSH-B-1	15/P		4	11						
		15/P		7	13						
41319927000	BUSH-6-2	35/P		5	16						
41319928000	GUIDE-SEP-BACK	11/P		5	11						
41319929000	GUIDE-V	11/P		5	21						
41319930000	PAD-PLATE	15/P		8	15						
41319931000	OIL-DAMPER	11/P		8	3						
41319932000	GUIDE-ARM-PICK	11/P		4	22						
41319933000	HOLDER-TRAY	21/P		3	26						
41319934000	BUSH-6-3	25/P		4	10						
		15/P		7	9						
41319935000	CLP-4.8	15/P		3	18						
41319936000	BAND-SG-130	25/P		4	16						
41319937000	CLP-H-1	15/P		2	27						
		15/P		3	5						
		15/P		4	17						
		15/P		6	15						
41319938000	CLP-H-2	65/P		3	23						
41319939000	CLP-LWS-1S	35/P		2	20						
		15/P		6	14						
41319940000	CLP-ES-0510	15/P		2	21						
41319941000	BUSHB-2	25/P		8	7						
41319943000	ASM-STAND	41/P		2	9						
41319947000	FLT30*06	210/P		6	104						
41319948000	FLT-30*08	810/P		2	105						
41319949000	TPHEX30*06-G-P	3310/P		2	101						
		210/P		8	104						
41319950000	TPHAN30*06-S-P	610/P		2	107						
41319951000	TPHEX30*06-G-P	510/P		2	102						
		610/P		3	102						
		510/P		4	106						
		410/P		5	108						
		210/P		6	102						
		210/P		8	102						
41319952000	TPHEX30*08-S-P	1110/P		1	101						
41319953000	TPHEX40*08-G-P	210/P		8	103						
41319954000	TPHEX30*08-G-M	110/P		4	101						
41319955000	TPHEX30*10-G-M	210/P		1	106						
		210/P		4	107						
		710/P		6	103						
		810/P		7	101						
		1210/P		8	101						
41319956000	TPHEX30*10-S-M	110/P		1	103						
41319957000	TPHEX30*12-G-M	410/P		6	101						
41319958000	TBID30*06-GLD	210/P		2	104						
41319959000	TBID30*08-GLD	210/P		1	102						
41319960000	BID30*04-GLD	210/P		4	102						
41319961000	BID30*06-GLD	310/P		1	105						
		210/P		7	104						
41319962000	BID40*06-GLD	210/P		2	108						
41319963000	ZPAN30*06-GLD	210/P		3	104						
41319964000	ERRD30-BLK	210/P		1	107						
41319965000	ERRD40-BLK	210/P		4	104						
		610/P		5	104						
		310/P		7	102						
41319966000	ERRD60-BLK	110/P		3	103						

PARTS NUMBER INDEX

PARTS NO.	PARTS NAME	QTY / PAGE	QTY / PACK	PAGE	ITEM NO.	PIR	B S I NO.	SERIAL NO.	REMARKS	LOCATION
41319966000	ERR060-BLK	110/P		4	105					
		110/P		7	103					
		410/P		8	105					
41319968000	WPIN30/10-BLK	110/P		4	5					
		110/P		6	12					
41319969000	WPIN30/14-BLK	210/P		8	8					
41319971000	LBL-P-SET	15/P		6	4					
41319972000	LBL-TRAY-SET-F	15/P		6	5					
41319973000	LBL-P-LIMIT	15/P		6	18					
		15/P		8	19					
41319974000	LBL-P-SET-TRY-L	11/KP		7	15					
41319975000	LBL-P-SET-TRY-R	11/KP		8	16					
41319979000	BKT-FENCE-STOP	11/P		6	23					
41319980000	SCREW-P-M3*10.3	110/P		6	105					