

TOSHIBA

SERVICE PARTS LIST
STAPLER

KK-1600

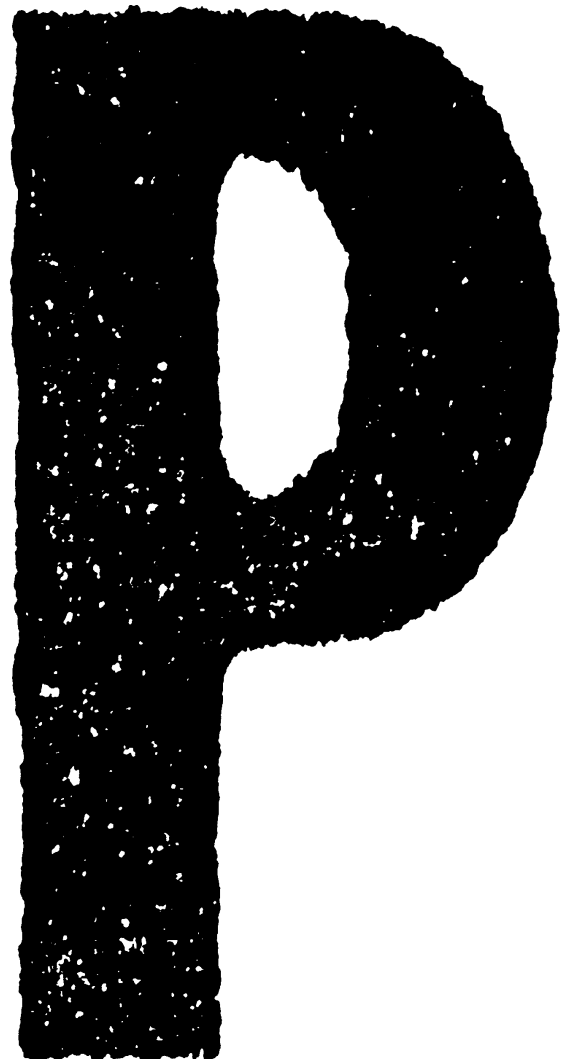

Copyright 2000

TOSHIBA TEC CORPORATION

EXPLANATION OF SERVICE-PARTS LIST

1. HOW TO READ THE PARTS LIST

- (1) Number of pieces
The number of pieces in the list denotes total pieces used per unit. But the numbers in the list for PACKING MATERIAL and ACCESSORY denote total pieces used per machine.
- (2) One pack of screws in the list includes 50 pieces.
- (3) ABBREVIATED CODES

QTY/PAC	{	QTY	one piece
		PAC	one pack
		1/P	one piece packed in polyethylene bag
		1/S	one piece packed in special pack
		1/C	one piece packed in carton box
		1/PP	one piece packed in paper and polyethylene bag
		1/KP	one piece packed in polyethylene bag with cardboard
		1/D	one piece packed in polyethylene-cushion bag
1/SB	one piece packed in shielding bag		
N/A	not available		

P	{	P	PURPOSE
		A	ADD
		B	DELETE
		C	CHANGE
		D	QTY, CHANGE
		E	MISENTRY
		F	OMISSION

I INTERCHANGEABILITY STATUS

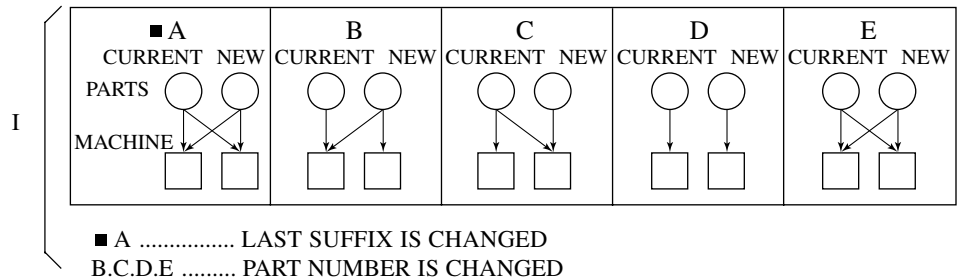

2. HOW TO PLACE ORDER FOR PARTS

- (1) The parts handled as service parts are only those with their "QTY/PACK" column listed with a quantity other than "N/A***" or "SUPPLY".
Those parts with "N/A***" are listed only for the purpose of showing the mechanical construction, those listed with "SUPPLY" are handled only as a sales item, and therefore both types of parts are not supplied as service parts.
- (2) Orders for any parts which form a component of a semi-assembled unit are not acceptable.
Note: All the screws and nuts used are ISO standard.

3. REGION

NAD	115V/60Hz, UL & CSA
TWD	110V/60Hz, TAIWAN
SAD	127V/60Hz, SAUDI ARABIA
ASD	220V
	50/60Hz, ASIA, etc.
AUD	240V/50Hz, AUSTRALIA
MJD	230-240V
	50/60Hz, EUROPE
UKD	230-240V
	50/60Hz, UNITED KINGDOM

NOTICE EXPLICATIVE DE LA LISTE DES PIÈCES DE RECHANGE

1. COMMENT UTILISER LA LISTE DES PIÈCES DE RECHANGE

(1) Nombre de pièces

Le nombre de pièces indiqué sur la liste est le nombre total de pièces utilisées pour chaque unité.

Toutefois, le nombre indiqué sur la liste EMBALLAGE ACCESSOIRES est le nombre total de pièces utilisées pour chaque machine.

(2) Un paquet de vis indiqué sur la liste contient 50 vis.

(3) ABREVIATIONS

Q'TY/PAC	QTY	une pièce
	PAC	un paquet
	1/P	une pièce emballée dans un sac en polyéthylène
	1/S	une pièce emballée dans un sac spécial
	1/C	une pièce emballée dans une boîte en carton
	1/PP	une pièce emballée dans un sac en papier et en polyéthylène
	1/KP	une pièce emballée dans un sac en polyéthylène avec carton
	1/D	une pièce emballée dans un sac rembourré en polyéthylène
	1/SB	une pièce emballée dans
N/A***	non disponible	

P BUT

P	A	AJOUTER
	B	SUPPRIMER
	C	MODIFIER
	D	CHANGEMENT DE QUANTITE
	E	INSCRIPTION ERRONEE
	F	OMISSION

I INTERCHANGEABILITE

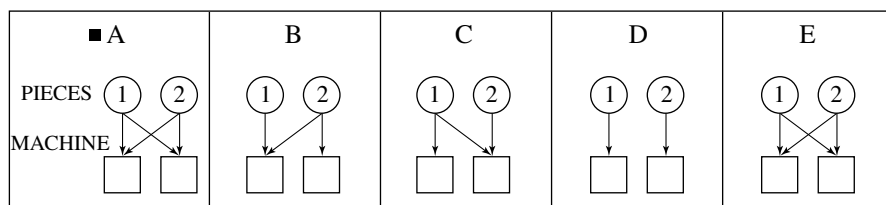

① ACTUELLE ② NOUVELLE

■ A LE DERNIER SUFFIXE EST CHANGE

B.C.D.E LE NOMBRE DE PIÈCES EST CHANGE

2. COMMENT COMMANDER LES PIÈCES

(1) Les pièces de rechange sont uniquement celles qui sont mentionnées dans la colonne "Q'TY/PACK" avec une quantité autre que "N/A***" ou "SUPPLY".

Les pièces dans la colonne "N/A***" sont mentionnées uniquement dans le but d'indiquer la construction mécanique. Les pièces dans la colonne "SUPPLY" sont destinées uniquement à la vente. Par conséquent, ces deux types de pièces ne sont pas fournies en tant que pièces de rechange.

(2) Les commandes de toute pièce formant un élément ou une unité semi-assemblée ne seront pas acceptées.

Nota: Toutes les vis et touts le écrous seront conformes au code ISO.

3. PAYS

NAD	115V/60Hz, UL & CSA
TWD	110V/60Hz, TAIWAN
SAD	127V/60Hz, ARABIE SAOUDITE
ASD	220V
	50/60Hz, ASIE, etc.
AUD	240V/50Hz, AUSTRALIE
MJD	230-240V
	50/60Hz, EUROPE
UKD	230-240V
	50/60Hz, ROYAUME-UNI

ERKLÄRUNG DES ERSATZTEIL-KATALOGES

1. WIE LIEST MAN DIE TEILELISTE?

- (1) Die Teileanzahl
Die Anzahl der Teile in der Liste, drücken die gesamten Teile pro Verpackungseinheit aus. Aber die Zahl in der Liste "Packing" (Verpackung) und "Accessory" (Zubehör) beschreibt die gesamte Teileanzahl pro Maschine.
- (2) Eine Verpackungseinheit SCHRAUBEN enthält 50 Stück.
- (3) Abkürzungscode

QTY/PAC	{	QTY	Stück
		PAC	Packung
		1/P	ein Stück in einem Plastikbeutel
		1/S	ein Stück in einer Spezialverpackung
		1/C	ein Stück in einem Karton
		1/PP	ein Stück in Papier und einem Plastikbeutel
		1/KP	ein Stück in einem Plastikbeutel mit Pappdeckel
		1/D	ein Stück in einem gepolsterten Plastikbeutel
N/A	nicht lieferbar		
1/SB	ein Stück in einer Schutzhülle		

P	{	P	Zweck
		A	Zusätzlich
		B	Entfernen
		C	Ändern
		D	Menge geändert
		E	Fehlangebe
		F	Weglassen

I Austauschbar untereinander

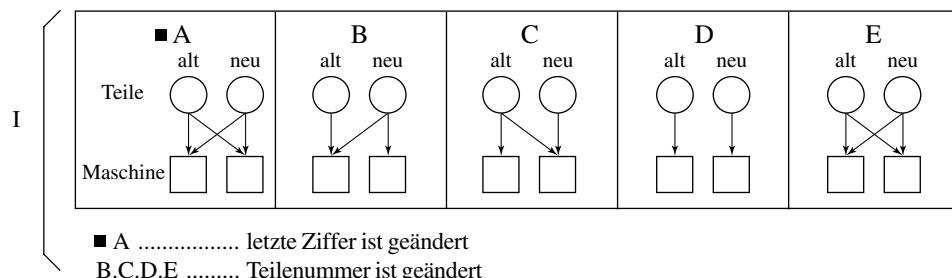

2. WIE WERDEN ERSATZTEILE BESTELLT?

- (1) Die Ersatzteile für den Service haben in der Spalte "QTY/PACK" eine Nummer.
Die Teile mit der Angabe "N/A***" sind nur aufgeführt, um die technische Konstruktion zu zeigen und sind einzeln nicht lieferbar.
Die Bezeichnung "SUPPLY" weist darauf hin, daß dieses Teil als Zubehör gehandelt wird und beim Verkauf bestellt werden muß.
- (2) Bestellungen für Einzelteile, die einer Baueinheit angehören können nicht akzeptiert werden.
Hinweis: Alle Schrauben und Muttern werden nach dem ISO-Standard hergestellt.

3. REGION

NAD	115V/60Hz, UL & CSA
TWD	110V/60Hz, TAIWAN
SAD	127V/60Hz, SAUDI-ARABIEN
ASD	220V 50/60Hz, ASIEN, usw.
AUD	240V/50Hz, AUSTRALIEN
MJD	230-240V 50/60Hz, EUROPA
UKD	230-240V 50/60Hz, GROSSBRITANNIEN

SPIEGAZIONE DELLA LISTA DEI PEZZI DI RICAMBIO

1. COME LEGGERE LA LISTA DEI PEZZI DI RICAMBIO

- (1) Numero dei pezzi
Il numero dei pezzi indica il totale dei pezzi per elemento. I numeri nella lista del materiale d'imballaggio e accessori indicano il totale dei pezzi per macchina.
- (2) Nella lista, un pacco di viti contiene 50 viti.
- (3) ABBREVIAZIONI

QTY/PAC	QTY un pezzo PAC un pacco 1/P un pezzo imballato in sacco di polietilene 1/S un pezzo imballato in pacco speciale 1/C un pezzo imballato in scatola di cartone 1/PP un pezzo imballato in sacco di polietilene e carta 1/KP un pezzo imballato in sacco di polietilene con cartone 1/D un pezzo imballato in sacco morbido di polietilene 1/SB un pezzo imballato in sacco di protezione N/A non disponibile
---------	-----------------------------------------------------------------------------------------------------------------------------------------------------------------------------------------------------------------------------------------------------------------------------------------------------------------------------------------------------------------------------------------------------------------------------------------------------------------------------------------------------

P	P scopo A aggiunta B annullamento C modifica D modifica QTY E ingresso errato F omissione
---	-------------------------------------------------------------------------------------------------------------------------------------------------------

I stato di intercambiabilità

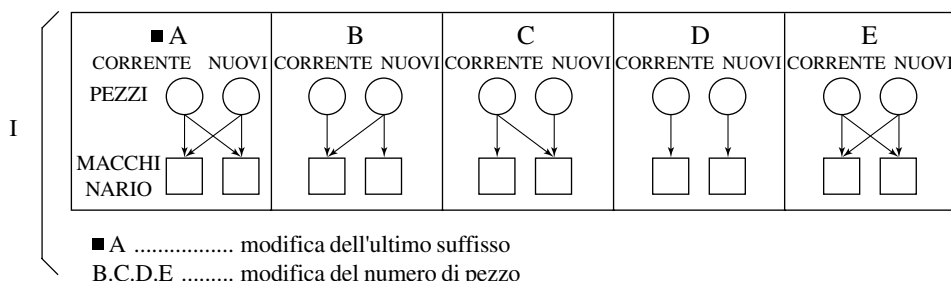

2. ORDINAZIONE DEI PEZZI

- (1) I pezzi usati come pezzi di ricambio sono elencati nella colonna "QTY/PACK" con una quantità differente da "N/A****" o "SUPPLY".
I pezzi con "N/A****" sono elencati solamente per mostrare la costruzione meccanica e quelli con "SUPPLY" sono elencati solamente come articoli di vendita: ciò significa che questi due tipi di pezzi non sono forniti come pezzi di ricambio.
- (2) L'ordinazione dei pezzi non viene accettata quando questi pezzi formano un componente di un messo elemento.
Nota: Tuttle le viti e i dadi sono standard ISO.

3. NAZIONE

NAD	115V/60Hz, UL & CSA
TWD	110V/60Hz, TAIWAN
SAD	127V/60Hz, ARABIA SAUDITA
ASD	220V 50/60Hz, ASIA, ecc.
AUD	240V/50Hz, AUSTRALIA
MJD	230-240V 50/60Hz, EUROPA
UKD	230-240V 50/60Hz, GRAN BRETAGNA

EXPLICACION DE LA LISTA DE PIEZAS DE SERVICIO

1. Cómo se lee la lista de piezas

- (1) El número de piezas
El número de piezas en la lista especifica las piezas totales usada pou unidad, mientras que el número en la lista para MATERIAL DE EMBALAJE y ACCESORIOS especifica las piezas totales usadas por máquina.
- (2) En el paquete de tornillos se incluyen 50 unidades.
- (3) Códigos abreviados

QTY/PAC	{	QTY	una pieza
		PAC	una paquete
		1/P	una pieza empaquetada en la bolsa de politileno
		1/S	una pieza empaquetada en paquete especial
		1/C	una pieza empaquetada en caja de cartón
		1/PP	una pieza empaquetada en papel y bolsa de politileno
		1/KP	una pieza empaquetada en bolsa de politileno con cartón
		1/D	una pieza empaquetada en bolsa almohadillada de politileno
1/SB	una pieza empaquetada en una		
N/A	bolsa protegida		

P	{	P	PROPOSITO
		A	AÑADIR
		B	BORRAR
		C	CAMBIO
		D	CANTIDAD, CAMBIO
		E	ENTRADA ERRONEA
		F	OMISION

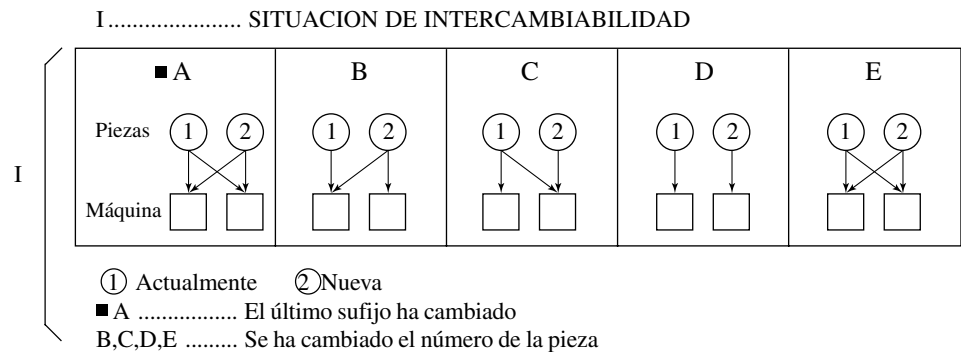

2. Cómo realizar un pedido de piezas

- (1) Las piezas consideradas como piezas de servicio son sólo aquellas designadas con Q'TY/PACK y no las designadas con N/A ... o SUPPLY.
Aquellas piezas con N/A ... se ponen en lista sólo con el propósito de mostrar la construcción mecánica. Aquéllas piezas designadas bajo SUPPLY se consideran sólo como un artículo para ventas y por lo tanto ambos tipos de piezas no se consideran como piezas de servicio.
- (2) Los pedidos para cualquier pieza que forme un componente de la unidad semiensamblada no será aceptados.
NOTA: todos los tornillos y tuercas son del estandar ISO.

3. PAISES

NAD	115V/60Hz, UL & CSA
TWD	110V/60Hz, TAIWAN
SAD	127V/60Hz, SAUDI ARABIA
ASD	220V
	50/60Hz, ASIA, etc.
AUD	240V/50Hz, AUSTRALIA
MJD	230-240V
	50/60Hz, EUROPA
UKD	230-240V
	50/60Hz, GRAN BRETAÑA

CONTENTS

ASM-STAPLER 1

PARTS NUMBER INDEX

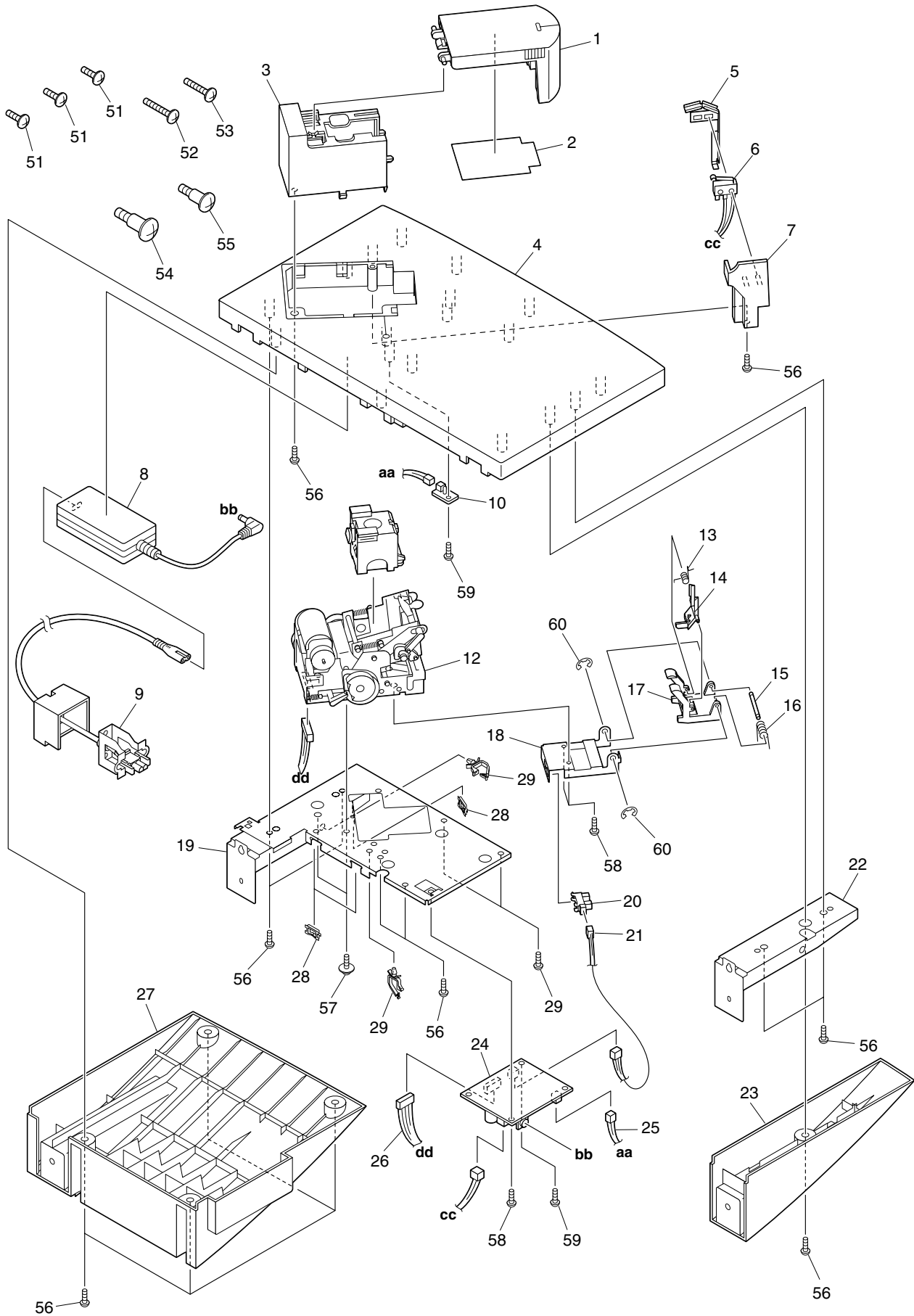

ITEM NO.	PARTS NO.	PARTS NAME	Q'TY / PAGE	Q'TY / PACK	P	I	R	BSI NO.	TO	FROM	SERIAL NO.	REMARKS	C
1	41306318000	COV-STAPLE-T	1	1/PP									
2	41306957000	LBL/W STAPLER-T	1	5/P									
3	41306317000	COV-MID-STPR-T	1	1/PP									
4	41306316000	BASE-STAPLER-T	1	1/PP									
5	41305086000	STY-SWITCH-STPR	1	1/P									
6	41301100000	ASM-SWITCH-STPR	1	1/C									
7	41306337000	COV-SW-STPR	1	1/P									
8	41306761000	PS-STAPLER	1	1/D									
9	41301101000	ASM-CABLE-STPR	1	1/P									
10	41300529000	PWA-LED-STPR	1	1/SB									
12	41306764000	ASM-STAPLE-UNIT	1	1/C									
13	41305565000	SPR-LEVER-STPR	1	1/P									
14	41306322000	ACTR-PPR-STPR	1	1/P									
15	41304554000	SFT-HLDR-STPR	1	1/P									
16	41305564000	SPR-HLDR-STPR	1	1/P									
17	41306321000	HLDR-ACTR-STPR	1	1/P									
18	41305089000	PLT-SENS-STPR	1	1/P									
19	41305087000	STY-BASE-STPR	1	1/P									
20	4843171487	SCO-GP1SQ73P	1	1/C									
21	41301098000	WH-SENS-STPR	1	1/P									
22	41305088000	FOOT-BASE-STPR	1	1/P									
23	41306319000	COV-FOOT-STPR-T	1	1/PP									
24	41300528000	PWA-STAPLER	1	1/SB									
25	41301097000	WH-LED-STPR	1	1/P									
26	41301099000	WH-STPR-UNIT	1	1/P									
27	41306320000	COV-PCB-STPR-T	1	1/PP									
28	4843390942	BD/W-EDS-2	3	10/P									
29	4843390554	CLP/W-LWS-1S	2	5/P									
51	4842041808	TB1DS-30*08-3C	3	50/P									
52	4842042085	BID30*18MSCR1A1	1	50/P									
53	4842042084	BID30*14MSCR1A1	1	50/P									
54	41306765000	SRW-M3-9.0-S	1	10/P									
55	41306766000	SRW-M3-S	1	10/P									
56	4842042083	TB1DB4012MSCR3C	15	50/P									
57	4842042086	TZPAN4006MSCR3C	2	50/P									
58	7043300413	BID30*04MSCR1A1	3	50/P									
59	4842042082	TB1DB3008MSCR3C	2	50/P									
60	4842090310	ERR030SKZN3A	2	50/P									

PARTS NUMBER INDEX

PARTS NO.	PARTS NAME	Q'TY / PAGE	Q'TY / PACK	PAGE	ITEM NO.	PIR	B S I NO.	SERIAL NO.	REMARKS	LOCATION	C
41300528000	PWA-STAPLER	11/SB	1	24							
41300529000	PWA-LED-STPR	11/SB	1	10							
41301097000	WH-LED-STPR	11/P	1	25							
41301098000	WH-SENS-STPR	11/P	1	21							
41301099000	WH-STPR-UNIT	11/P	1	26							
41301100000	ASM-SWITCH-STPR	11/C	1	6							
41301101000	ASM-CABLE-STPR	11/P	1	9							
41304554000	SFT-HLDR-STPR	11/P	1	15							
41305086000	STY-SWITCH-STPR	11/P	1	5							
41305087000	STY-BASE-STPR	11/P	1	19							
41305088000	FOOT-BASE-STPR	11/P	1	22							
41305089000	PLT-SENS-STPR	11/P	1	18							
41305564000	SPR-HLDR-STPR	11/P	1	16							
41305565000	SPR-LEVER-STPR	11/P	1	13							
41306316000	BASE-STAPLER-T	11/PP	1	4							
41306317000	COV-MID-STPR-T	11/PP	1	3							
41306318000	COV-STAPLE-T	11/PP	1	1							
41306319000	COV-FOOT-STPR-T	11/PP	1	23							
41306320000	COV-PCB-STPR-T	11/PP	1	27							
41306321000	HLDR-ACTR-STPR	11/P	1	17							
41306322000	ACTR-PPR-STPR	11/P	1	14							
41306337000	COV-SW-STPR	11/P	1	7							
41306761000	PS-STAPLER	11/D	1	8							
41306764000	ASM-STAPLE-UNIT	11/C	1	12							
41306765000	SRW-M3-9.0-S	110/P	1	54							
41306766000	SRW-M3-S	110/P	1	55							
41306957000	LBL/W STAPLER-T	15/P	1	2							
4842041808	TBIDS-30*08-3C	350/P	1	51							
4842042082	TBIDB3008MSCR3C	250/P	1	59							
4842042083	TBIDB4012MSCR3C	1550/P	1	56							
4842042084	BID30*14MSCR1A1	150/P	1	53							
4842042085	BID30*18MSCR1A1	150/P	1	52							
4842042086	TZPAN4006MSCR3C	250/P	1	57							
4842090310	ERR030SKZN3A	250/P	1	60							
4843171487	SCO-GP1SQ73P	11/C	1	20							
4843390554	CLP/W-LWS-1S	25/P	1	29							
4843390942	BD/W-EDS-2	310/P	1	28							
7043300413	BID30*04MSCR1A1	350/P	1	58							

TOSHIBA

TOSHIBA TEC CORPORATION

1-1, KANDA NISHIKI-CHO, CHIYODA-KU, TOKYO, 101-8842 JAPAN