

TOSHIBA

SERVICE MANUAL
AUTOMATIC DOCUMENT FEEDER

MR-2012



General Precautions for Installation/Service/Maintenance for the MR-2012

The installation and service should be done by a qualified service technician.

1. When installing the MR-2012 to the Plain Paper Copier, be sure to follow the instructions described in the "Unpacking/Set-Up Procedure for the MR-2012" booklet which comes with each unit of the MR-2012.
2. The MR-2012 should be installed by an authorized/qualified person.
3. Before starting installation, servicing or maintenance work, be sure to turn off and unplug the copier first.
4. When servicing or maintaining the MR-2012, be careful about the rotating or operation sections such as gear, pulleys, sprockets, cams, belts, etc.
5. When parts are disassembled, reassembly is basically the reverse of disassembly unless otherwise noted in this manual or other related materials. Be careful not to reassemble small parts such as screws, washers, pins, E-rings, toothed washers to the wrong places.
6. Basically, the machine should not be operated with any parts removed or disassembled.
7. Delicate parts for preventing safety hazard problems (such as breakers, thermofuses, fuses, door switches, sensors, etc. if any) should be handled/installed/adjusted correctly.
8. Use suitable measuring instruments and tools.
9. During servicing or maintenance work, be sure to check the serial No. plate and other cautionary labels (if any) to see if they are clean and firmly fixed. If not, take appropriate actions.
10. The PC board must be stored in an anti-electrostatic bag and handled carefully using a wristband, because the ICs on it may be damaged due to static electricity. Before using the wrist band, pull out the power cord plug of the copier and make sure that there is no uninsulated charged objects in the vicinity.
11. For the recovery and disposal of used MR-2012, consumable parts and packing materials, it is recommended that the relevant local regulations/rules should be followed.
12. After completing installation, servicing and maintenance of the MR-2012, return the MR-2012 to its original state, and check operation.

Copyright 2000

TOSHIBA TEC CORPORATION

CONTENTS

1. SPECIFICATIONS	1-1
2. OUTLINE	2-1
2.1 Names of Various Components	2-1
2.2 Layout of Electrical Parts	2-2
2.3 Harness Connection Diagram	2-4
2.4 Board Assembly	2-5
3. OPERATIONAL DESCRIPTION	3-1
3.1 General Operation	3-1
3.2 Block Diagram	3-1
3.3 Detection of Abnormal Status	3-2
3.3.1 Cover open/Close detection	3-2
3.3.2 Feeder jam detection	3-2
3.3.3 ADF registration sensor stay jam detection	3-2
3.3.4 ADF read sensor unreached jam detection	3-2
3.3.5 ADF read sensor stay jam detection	3-2
3.3.6 ADF exit sensor unreached jam detection	3-2
3.4 Flow Chart	3-3
4. MECHANICAL DESCRIPTION	4-1
4.1 Paper Feed System	4-1
4.2 Document Size Detection Method	4-2
4.3 Drive System	4-4
5. CIRCUIT DESCRIPTION	5-1
5.1 PWA Block Diagram	5-1
5.2 Detection Circuit	5-1
5.3 ADF Read Sensor Input Circuit	5-2
5.4 ADF Motor Drive Circuit	5-3
5.5 Meaning of Signals	5-4
5.6 Timing Chart	5-5
6. DISASSEMBLY AND REPLACEMENT	6-1

1. SPECIFICATIONS

Function	: Auto document feeder
No. of originals loaded	: Up to 50 originals (13 to 29 lb)
Document size	: A5-R (Min.) to A3 (Max.)
Dimensions	: 530 (W) x 450 (D) x 120 (H) mm
Weight	: Approx. 5.4 kg
Power supply	: 5V, 24V (Supplied from copier)

2. OUTLINE

2.1 Names of Various Components

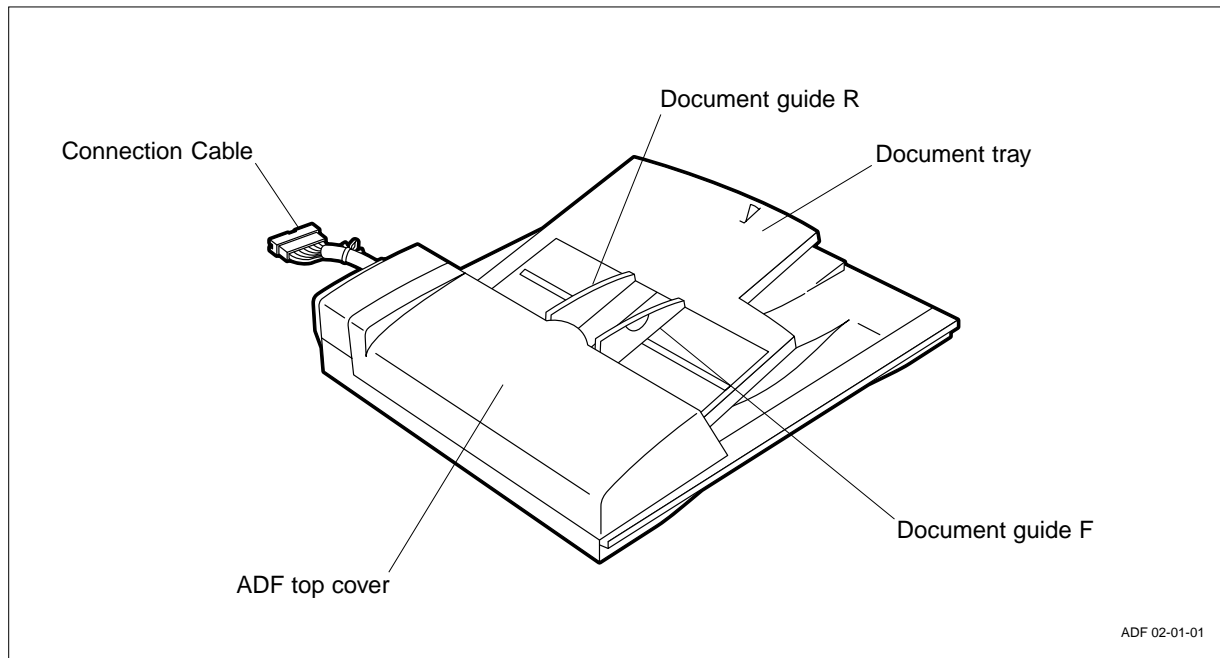

2.2 Layout of Electrical Parts

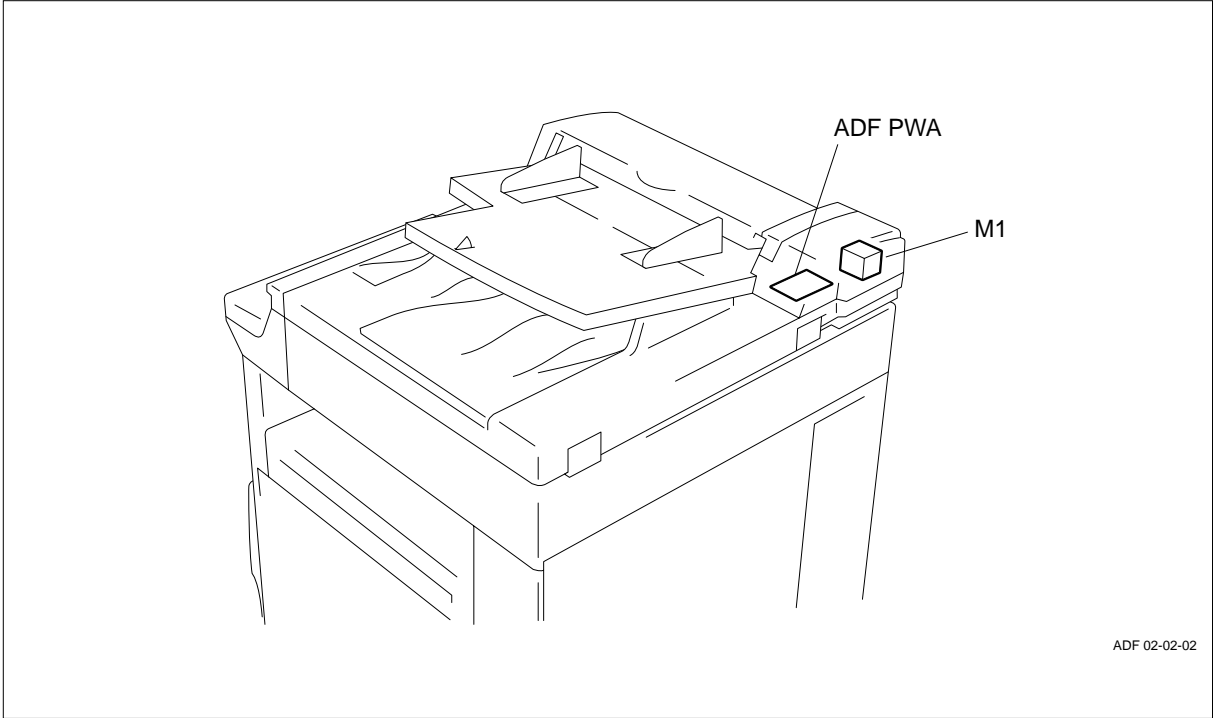
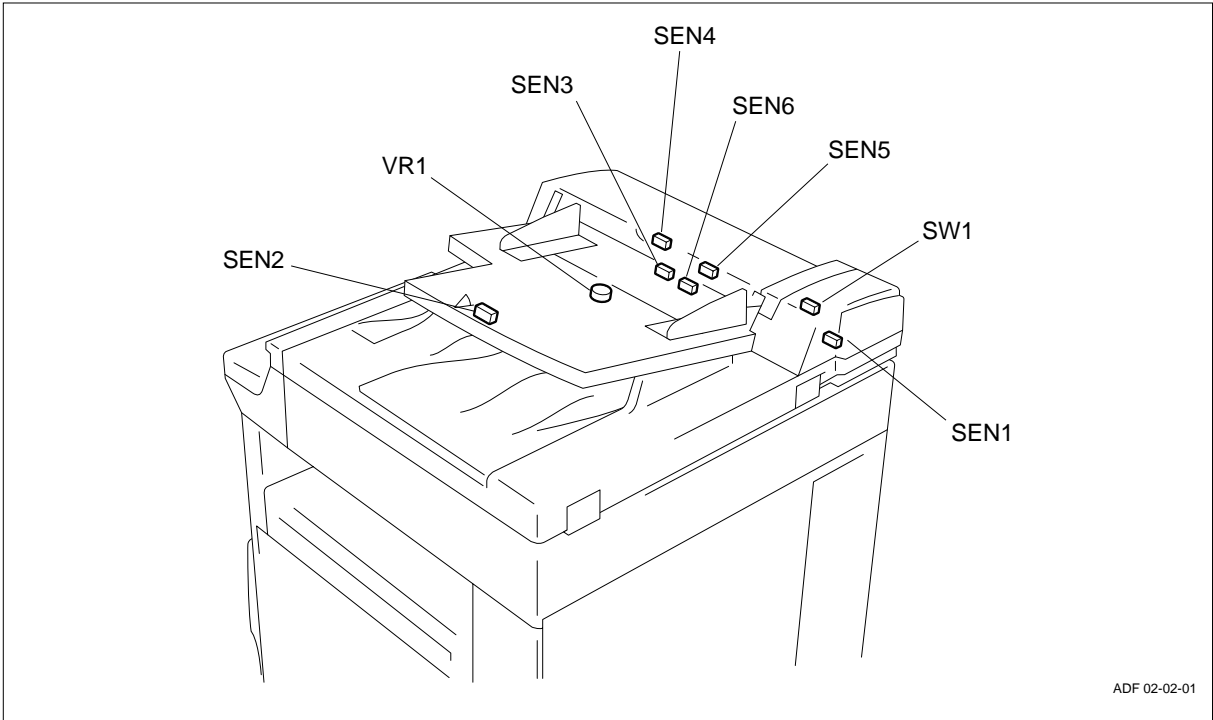

Symbols and functions of various devices

Symbol	Name	Function
SW1	ADFCOV-SW ADF top cover open switch	Detects the open/close state of the top cover during jamming processing, etc.
VR1	WIDTH-VR Document width sensor	Detects the width of document.
SEN1	ADFOPN-SEN ADF open sensor	Detects the open/close state of the ADF unit.
SEN2	SIZE-SEN Document length sensor	Detects the length of document.
SEN3	EMPTY-SEN Document empty sensor	Detects the loading of document.
SEN4	REGST-SEN ADF registration sensor	Detects the aligning position of document.
SEN5	POS-SEN ADF read sensor	Detects the document scanning start position.
SEN6	HAISI-SEN ADF exit sensor	Detects the ejection of document.
ADF	ADF PWA	PWA which relays the sensor signals and motor drive signals.
M1	ADF-MOT ADF motor	Drives the roller to transport originals.

2.3 Harness Connection Diagram

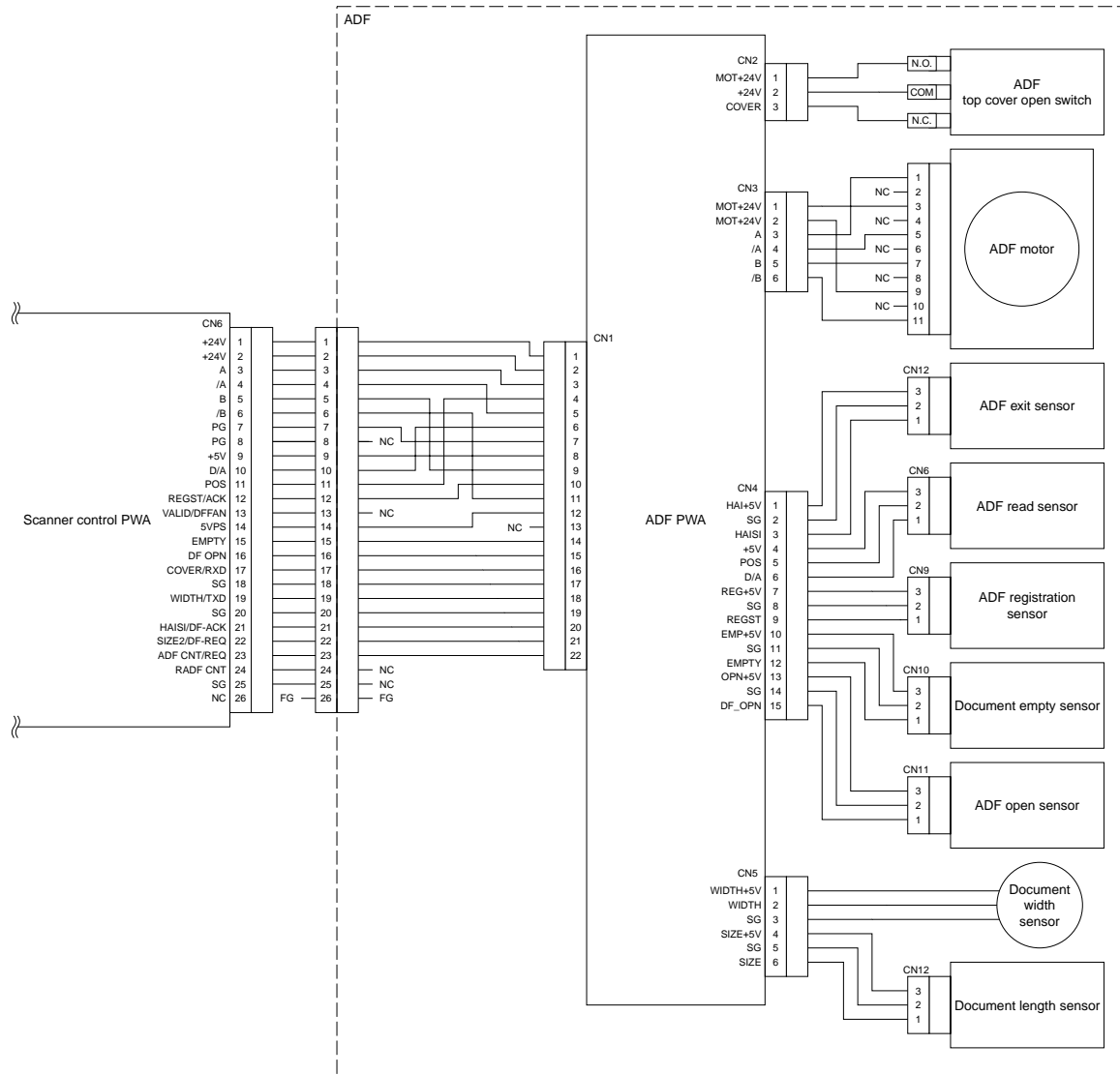

ADF 02-03-01

2.4 Board Assembly

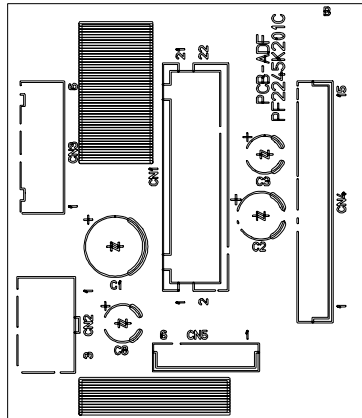

ADF 02-04-01

3. OPERATIONAL DESCRIPTION

3.1 General Operation

The ADF is an auto document feed unit capable of accommodating a maximum of 50 originals. The originals loaded are fed and scanned one by one and stacked on the exit tray. The ADF has a mechanical section for document transport, sensors to detect the position of document, etc., and a motor for transport. It also has one PWA where comparator IC's only are installed and the other signals simply pass. For this reason, all control and processing are performed by the scanner PWA.

3.2 Block Diagram

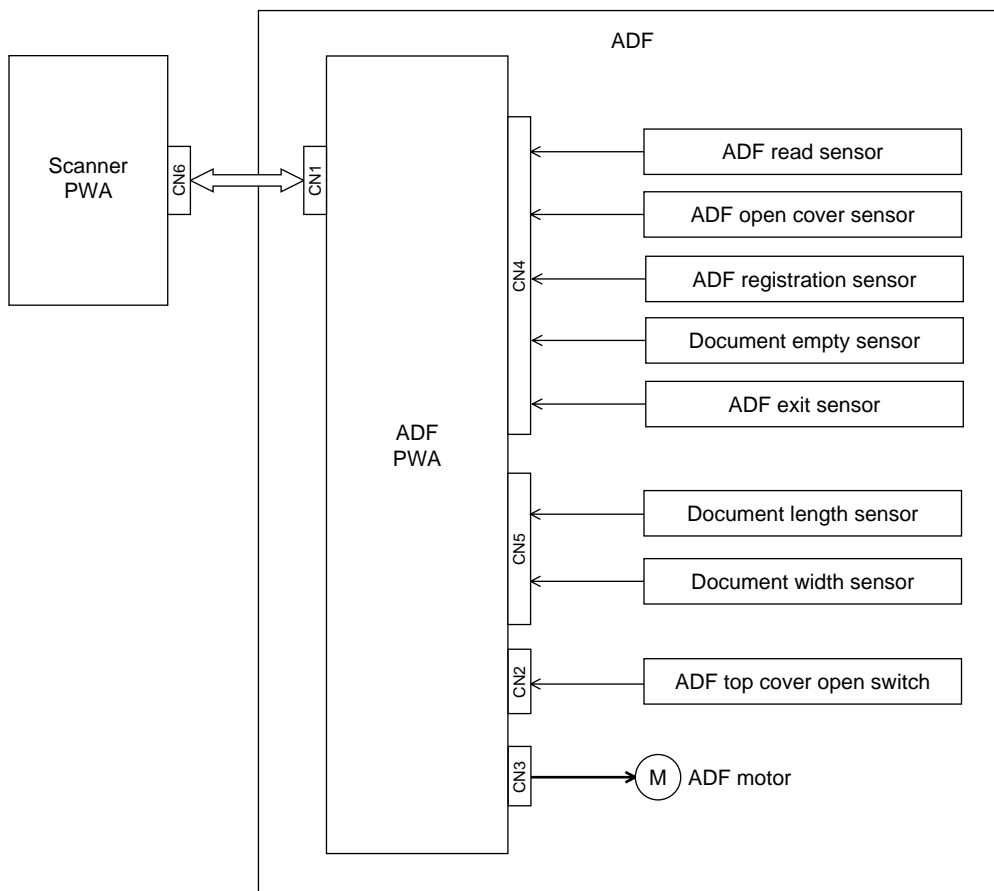

ADF 03-02-01

3.3 Detection of Abnormal Status

3.3.1 Cover open/Close detection

When the ADF top cover is opened, the contact of the ADF top cover open switch changes to cut the supply of 24V to the motor and sends a cover open detection signal to the scanner PWA.

3.3.2 Feeder jam detection

The number of pulses (time) equivalent to the distance (①) from the document set position to the ADF registration sensor ON position plus 300 mm is regarded as timing for detecting a jam. When the time from the moment of starting paper feed to the moment when the ADF registration sensor is turned ON exceeds that value, a jam in the feeder will be detected.

3.3.3 ADF registration sensor stay jam detection

The number of pulses (time) equivalent to the distance obtained by subtracting 115 mm (② + ③) from the document length plus 30 mm (1115 mm for long mode) is regarded as timing for detecting a jam. When the time from the moment when the ADF exit sensor is turned ON to the moment when the ADF registration sensor is turned OFF exceeds that value, a ADF registration sensor stay jam will be detected.

3.3.4 ADF read sensor unreached jam detection

The number of pulses (time) equivalent to the distance (②) from the ADF registration sensor to the ADF read sensor plus 30 mm is regarded as timing for detecting a jam. When the time from the moment of starting the transport of the document having reached the ADF registration sensor to the moment when the ADF read sensor is turned ON exceeds that value, an ADF read sensor unreached jam will be detected.

3.3.5 ADF read sensor stay jam detection

The number of pulses (time) equivalent to the distance (②) from the ADF registration sensor to the ADF read sensor plus 30 mm is regarded as timing for detecting a jam. When the time taken after the end of the document passes the ADF registration sensor exceeds that value, an ADF read sensor stay jam will be detected.

3.3.6 ADF exit sensor unreached jam detection

The number of pulses (time) equivalent to the distance (③) from the moment when the ADF read sensor is turned ON to the moment when the exit sensor is turned ON plus 35 mm is regarded as timing for detecting a jam. When the time taken after the top of the document passes the ADF read sensor exceeds that value, an ADF exit sensor unreached jam will be detected.

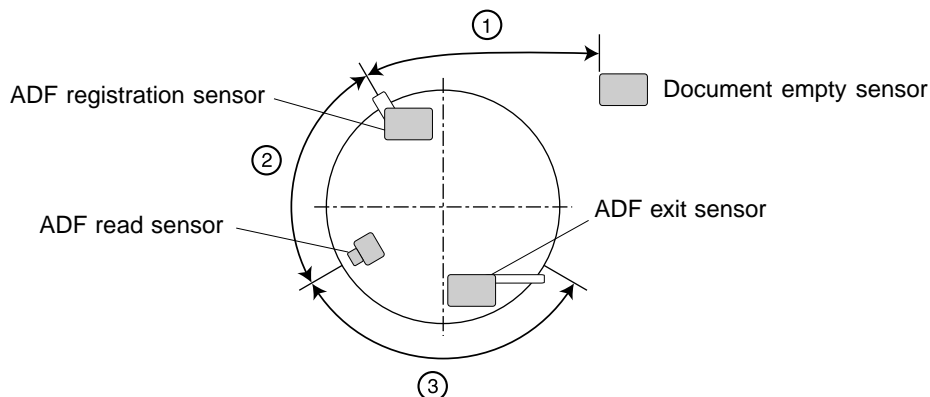

adf 03-03-06

3.4 Flow Chart

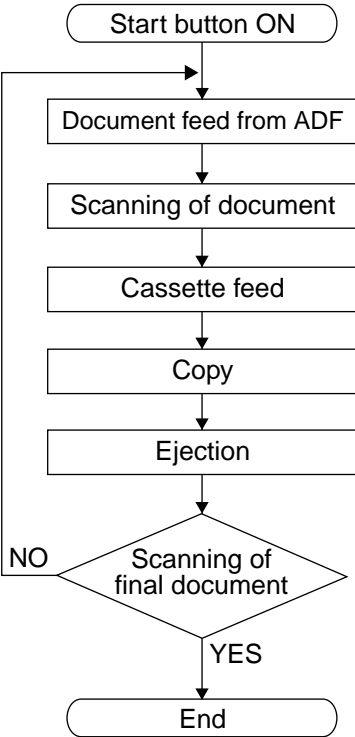

4. MECHANICAL DESCRIPTION

4.1 Paper Feed System

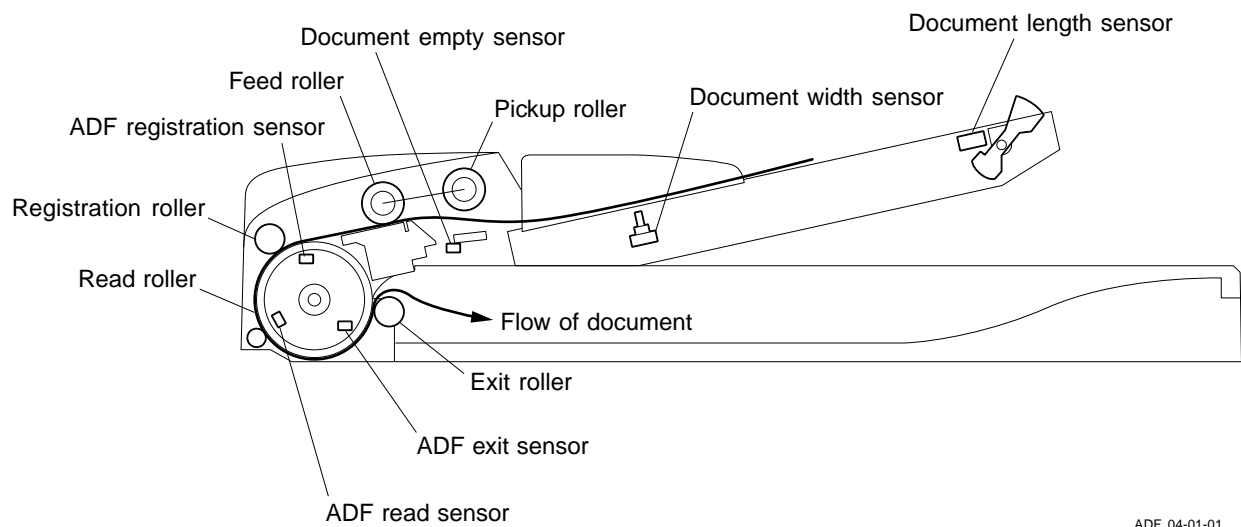

ADF 04-01-01

Transport of Document

When a document is placed in the tray, the document empty sensor detects the presence of a document. When the Start button is pressed on the copier while in ADF mode, the ADF motor operates to lower the pickup roller and pull in the document. Where there are more than one document, they are separated by the separation pad under the feed roller and transported one by one.

The document transported by the feed roller is detected by the ADF registration sensor and then stopped when the leading edge of the document reaches the registration roller after being fed for a certain distance. This feed amount can be adjusted by the aligning amount adjustment (05-354).

Then, the read roller rotates and the scanner starts scanning when the document reaches the ADF read sensor.

The scanned document passes over the ADF exit sensor, then is ejected by the exit roller.

4.2 Document Size Detection Method

The size of document is found by detecting the document width by the document width sensor, and the document length by the document length sensor. When documents of different sizes are placed in the tray, this detection method allows the maximum size of the documents to be detected. The document size is detected according to the timing with which the document empty sensor is turned ON, the timing with which the document width sensor changes, and the timing with which the document length sensor changes. The detected size is sent to the copier.

When the ADF is on standby or the document empty sensor is ON, the document width sensor is checked every 100 ms and the value obtained is compared with that of the last time. If the value is found changed as a result of the comparison, the document size will be detected and sent to the copier when in ADF active mode. When this unit receives a command accompanied by a document size notice request from the copier, it will also detect and send the document size to the copier.

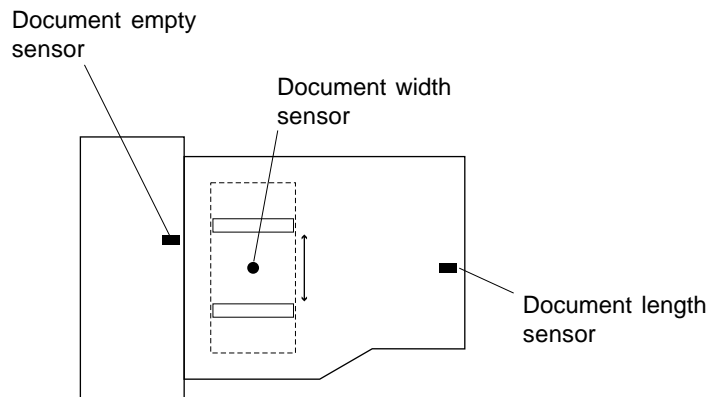

adf 04-02-01

ADF as viewed from top

The detection results of the document size sensors are listed below. (Unit: mm)

A4 series

Document width	Document length sensor (*1)	
	OFF	ON
129.40 - 165.99	A5R (148 x 210)	
166.00 - 196.99	B5R (182 x 257)	
197.00 - 233.99	A4R (210 x 297)	FOLIO (210 x 330)
234.00 - 277.99	B5 (257 x 182)	B4 (257 x 364)
278.00 - 310.00	A4 (297 x 210)	A4 (297 x 420)

(*1: ON for a document length of 306 mm)

LT series

Document width	Document length sensor (*1)	
	OFF	ON
129.40 - 177.99	STR (139.7 x 215.9)	
178.00 - 236.99	LTR (215.9 x 279.4)	LG (215.9 x 355.6)
237.00 - 268.99	COMPUTER (257.2 x 356)	
269.00 - 310.00	LT (279.4 x 215.9)	LD (279.4 x 431.8)

(*1: ON for a document length of 306 mm)

4.3 Drive System

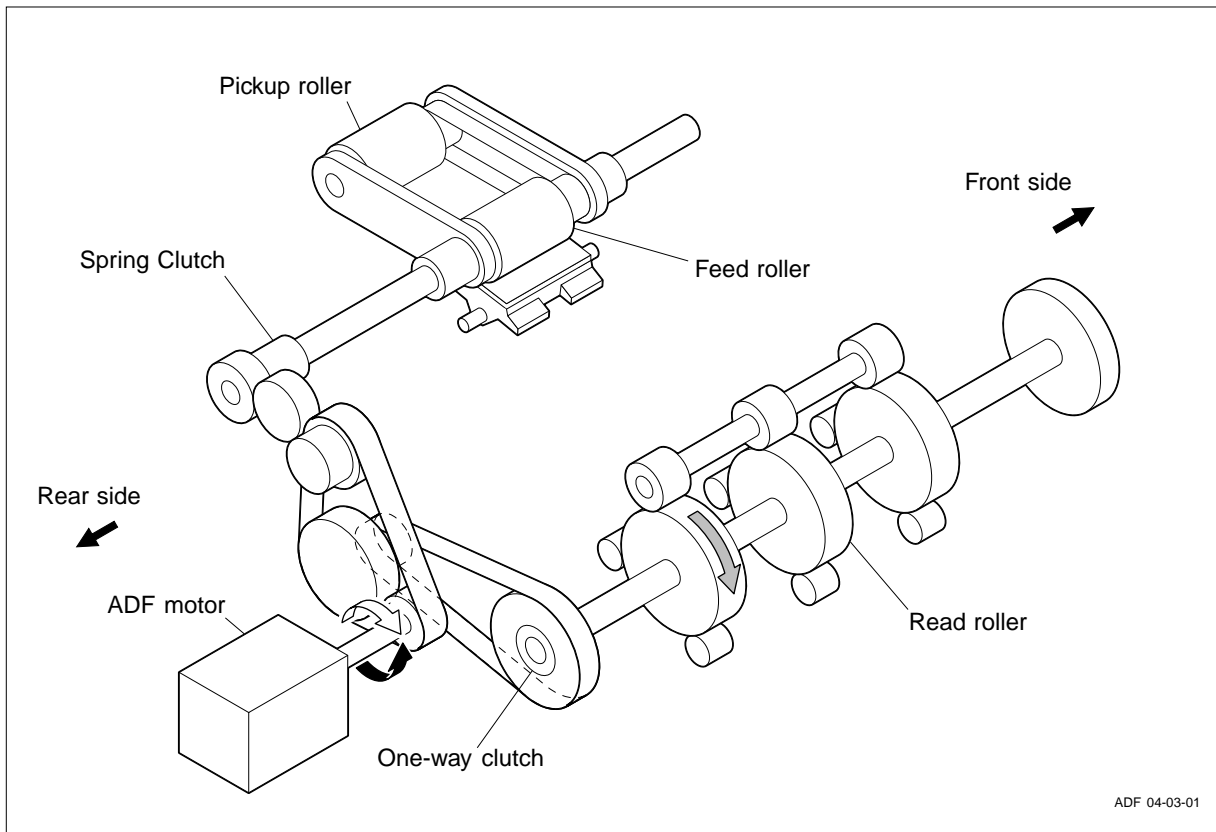

The driving force of the ADF motor is transmitted to each roller through the gears and belts. It is transmitted to the feed rollers through the timing belt and gears (3 pcs.) and further transmitted to the pickup roller through the timing belt. The driving force is transmitted to the read roller through the two timing belts and the gears connecting them. The shaft part of the read roller is provided with a one-way clutch allowing the driving force of the ADF motor to be transmitted only in the transport direction (counterclockwise) for rotation.

Document Feed

The document is fed as the ADF motor turns clockwise as viewed from the front (in the direction of the black arrow). When the ADF motor turns clockwise, the pickup roller lowers to pull in the document. At this time, the read roller does not turn due to the function of the one-way clutch.

Document Transport

The document is transported as the ADF motor turns counterclockwise as viewed from the front (in the direction of the white arrow). When the ADF motor turns counterclockwise, the pickup roller ascends causing the spring clutch mounted on the feed roller shaft to slip so that the driving force is no longer transmitted.

5. CIRCUIT DESCRIPTION

5.1 PWA Block Diagram

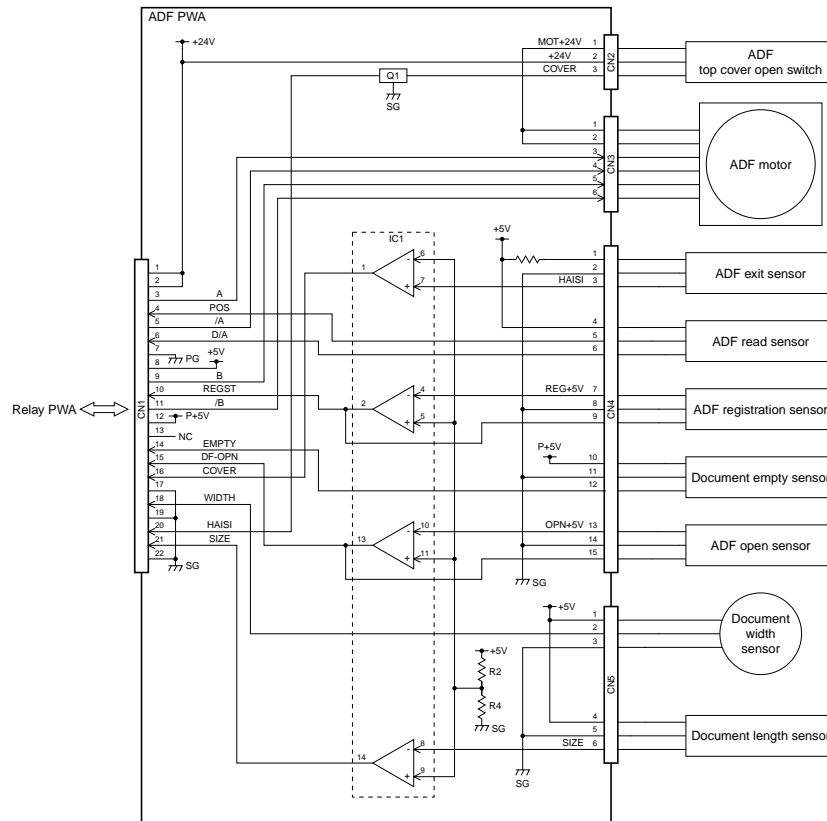

ADF 05-01-01

5.2 Detection Circuit

The ADF top cover open switch detects the open or close state of the ADF top cover. 24V is supplied to the motor when the cover is closed, and switches to the transistor Q1 side when open. The output of Q1 turns to “Low” level when the cover is open and the detection signal is sent to the scanner PWA from CN1.

The document width sensor uses a variable resistor for its detection element. It divides the voltage of 5V through the variable resistor and sends the output to the scanner PWA. The scanner PWA A-D converts the input voltage to calculate the document width.

The outputs of the ADF exit sensor, ADF registration sensor, ADF open sensor, and document length sensor each are input to the IC1 comparator. The reference voltage obtained by dividing 5V through R2 and R4 is input to the other input of the comparator. The detection level of each sensor is stabilized according to this reference voltage value and output from the comparator. Since the document empty sensor does not require accuracy for detecting the presence of a document, its output signal simply passes through the ADF PWA.

5.3 ADF Read Sensor Input Circuit

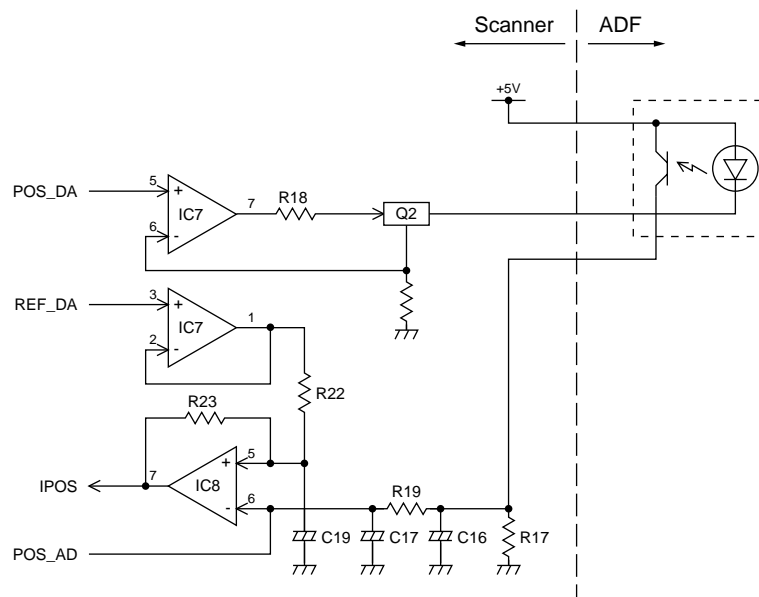

ADF 05-03-01

The ADF read sensor input circuit is installed on the scanner PWA. The ADF PWA only allows the signal only to pass through. Therefore, this section describes the ADF read sensor input circuit on the scanner PWA.

The ADF read sensor is a mirror reflective type sensor and consists of a pair of an infrared LED and a PTr (phototransistor) each having an optical axis in the same direction. A mirror is provided on an extended line of the optical axis of the sensor. When there is no document between the sensor and the mirror, an infrared light emitted from the LED is reflected to PTr at high reflectance. When there is a document between them, the emission to the mirror and the reflected light from the mirror are obstructed by the document so that the reflected light incident on PTr becomes extremely low. When a quantity of light incident on PTr is large (no document present), photoelectric current flowing through PTr increases and a drop in voltage due to R17 causes the voltage at pin 6 of IC8 to rise.

IC8 is a comparator which compares the reference voltage input to pin 5 (non-inverting input) with the signal voltage at pin 6 (inverting input). When the voltage at pin 6 is higher, the output (pin 7 of IC8) turns to "Low" level. Conversely, when a quantity of light incident on PTr is small (a document present), the voltage at pin 6 of IC8 becomes low and as a result pin 7 of IC8 turns to "High" level.

An automatic sensitivity adjusting function is also provided to control variations in sensor sensitivity. When the sensor sensitivity adjust mode is selected, the automatic adjustment measures the output voltage (analog value) of PTr at the A-D input terminal on the scanner side, changes the D-A output voltage on the scanner side to make the PTr output voltage become the required voltage, and adjusts the LED current through the voltage-current conversion circuit consisting of IC7, Q2, R20, etc.

5.4 ADF Motor Drive Circuit

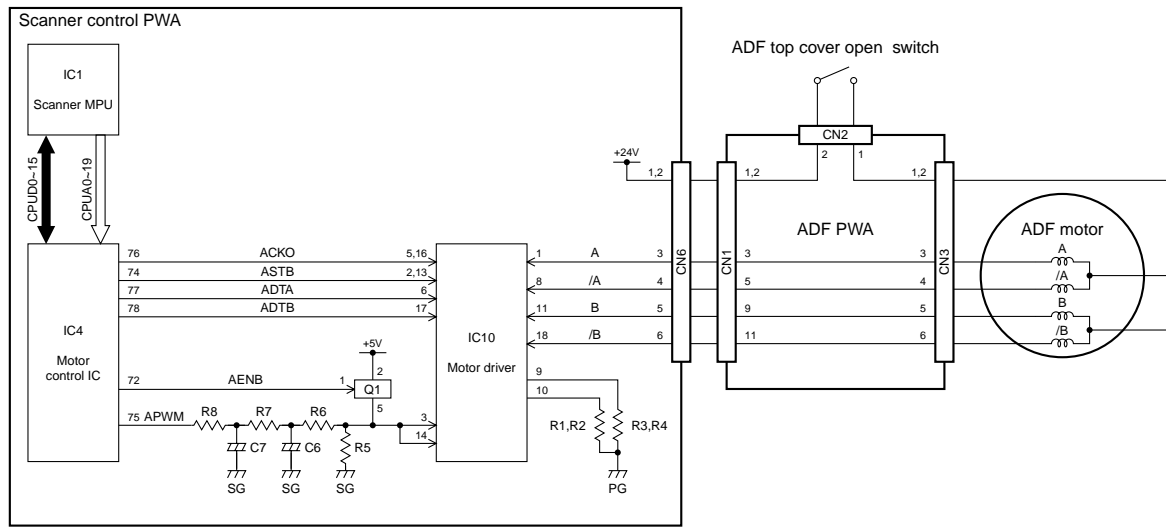

ADF 05-04-01

The ADF motor operates according to the driving signals from the scanner PWA. The signals only pass through the ADF PWA. Therefore, this section describes the ADF motor drive circuit on the scanner PWA.

The ADF motor is driven by amplifying the pulse motor driving pattern signals output from the gate array through the IC10 motor driver. These signals control the motor rotational direction and speed. The PWM signal is input to APWM and converted to a certain voltage through the resistor and capacitor. The voltage is input to IC10 (pins 3 and 14) to set the current value for the motor.

The current value for the motor can be set as desired by changing the duty of the PWM signal. AENB is a signal to control the output of the motor driver. When the signal is at "High" level, the output of the driver becomes effective.

5.5 Meaning of Signals

Signal name	Part name	Functional description	Status	Note
COVER	ADF top cover open switch	Detects the open/close state of the top cover during jamming processing, etc.	-	Microswitch
DF_OPN	ADF open sensor	Detects the open/close state of the ADF unit.	Low: Open	Photo sensor
SIZE	Document length sensor	Detects the length of document.	Low: Document present	Photo sensor
WIDTH	Document width sensor	Detects the width of document.	-	Variable resistor
EMPTY	Document empty sensor	Detects the loading of document.	Low: Document present	Photo sensor
REGST	ADF registration sensor	Detects the aligning position of document.	Low: Document present	Photo sensor
POS	ADF read sensor	Detects the document scanning start position.	Low: Document present	Photo sensor
HAISI	ADF exit sensor	Detects the ejection of document.	Low: Document present	Photo sensor

The ADF top cover open switch detects the open or close state of the cover and uses a 2-circuit microswitch. 24V is supplied to the motor when the cover is closed, and cut when open.

The ADF open sensor detects the open/close state of the ADF unit. A photo sensor is used for the sensor.

The document length sensor detects the length of the document placed in the document tray. A photo sensor is used for the sensor. It turns ON when the document length exceeds 306 mm.

The document width sensor detects the width of the document. A variable resistor is used for the sensor. The resistive value changes as the document width guide is slid.

The ADF empty sensor detects the document placed in the document tray. A photo sensor is used for the sensor.

The ADF registration sensor detects the document position in the transport path. A photo sensor is used for the sensor. It detects a paper jam in combination with other sensors.

The ADF read sensor detects the document scanning start position. A mirror reflective type photo sensor is used for the sensor. It detects the presence or absence of a document according to the strength of reflected light from the mirror.

The document exit sensor detects the ejection of a document. A photo sensor is used for the sensor.

5.6 Timing Chart

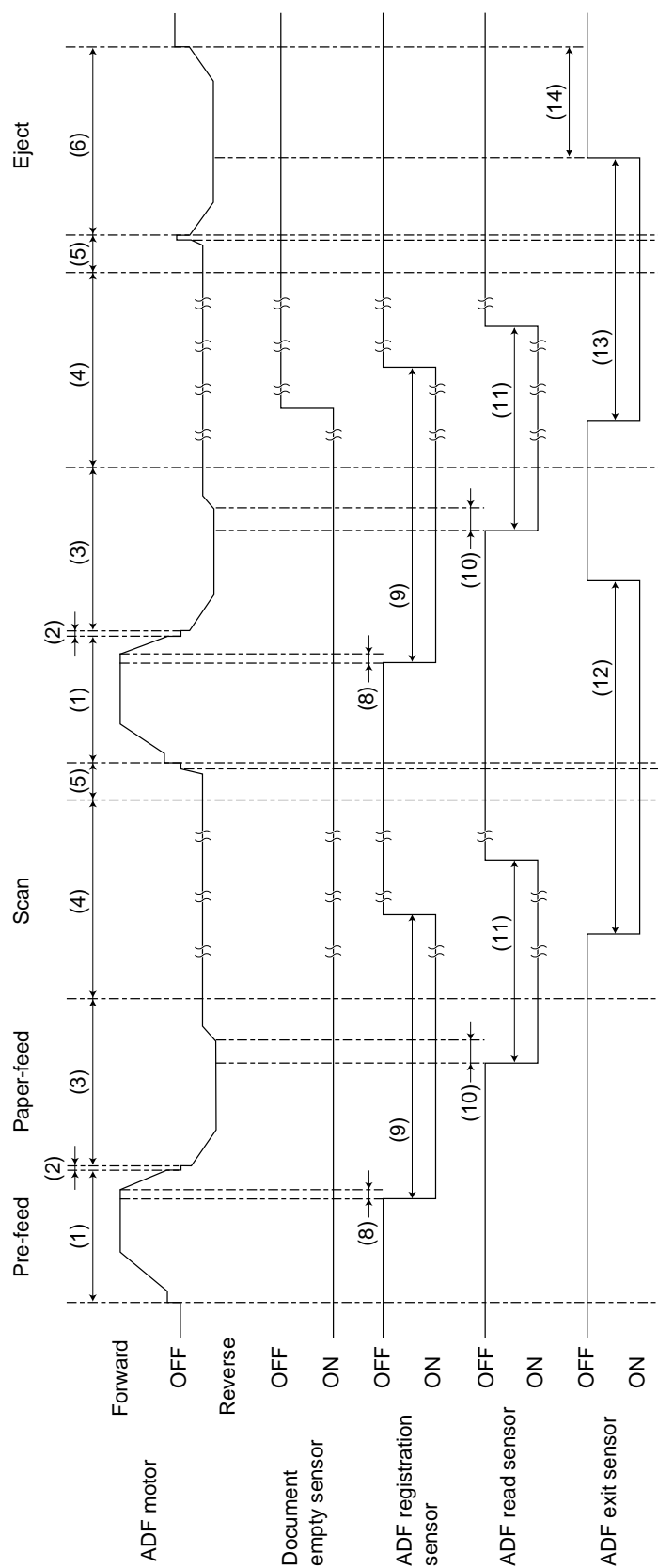

ADF 05-06-01

6. DISASSEMBLY AND REPLACEMENT

[A] ADF unit

1. Release 2 hooks, and detach ADF cover.
2. Release the clamp and detach one connector.

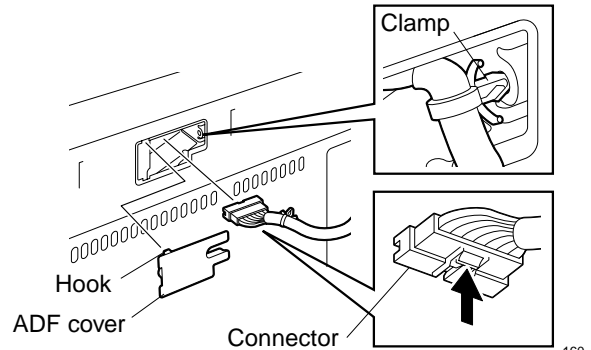

Fig. 6-1

3. Open ADF unit and take it out by lifting.

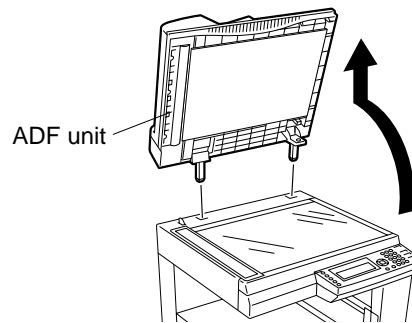

Fig. 6-2

[B] Document tray assembly

1. Open ADF top cover.

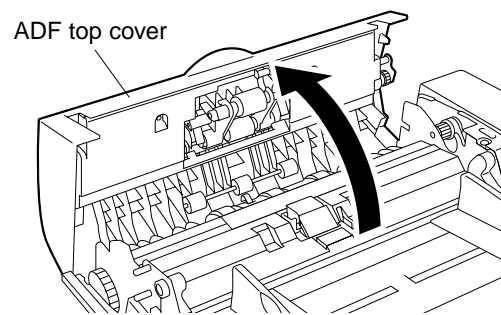

Fig. 6-3

2. Remove one screw, release 3 hooks, and detach ADF cover R.
3. Detach one connector from ADF PWA (CN5).

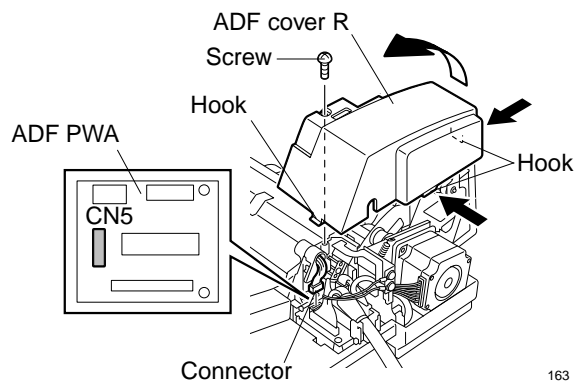

Fig. 6-4

4. Remove one screw and remove document tray support.
5. Detach document tray support from the harness.
6. Move document tray assembly in the direction of the arrow and remove it.

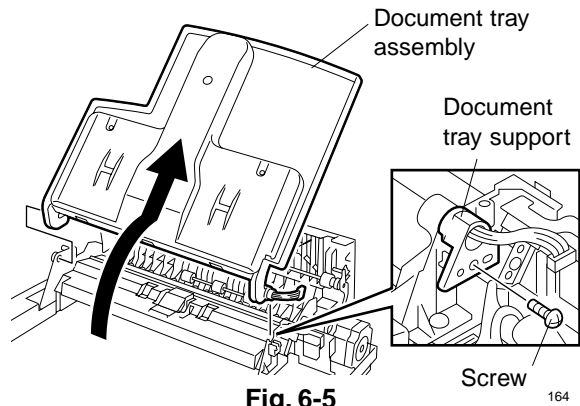

Fig. 6-5

[C] Document tray cover

1. Remove ADF. (See Fig. 6-1 and 6-2)
2. Remove document tray assembly. (See Fig. 6-3 to 6-5)
3. Remove 3 screws and detach document tray cover.

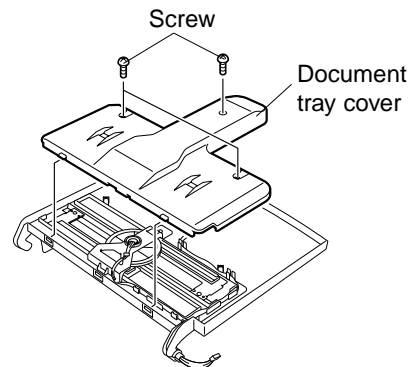

Fig. 6-6

[D] Document width sensor assembly

1. Remove ADF. (See Fig. 6-1 and 6-2)
2. Remove document tray assembly. (See Fig. 6-3 to 6-5)
3. Detach document tray cover. (See Fig. 6-6)
4. Release the harness from the clamp and detach the document length sensor harness.
5. Remove one screw, release the hook, and remove document width sensor assembly.

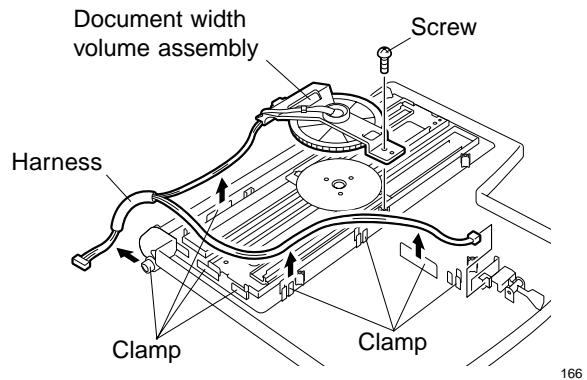

Fig. 6-7

- Notes:**
1. Align the arrow (↑) mark of sensor holder with that of document guide gear.
 2. Align the cut part of document guide rack with the triangle mark (▲) of document guide gear.

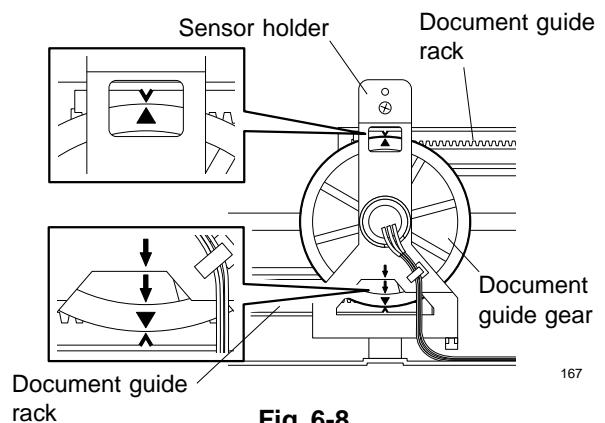

Fig. 6-8

[E] ADF top cover assembly

1. Remove document tray assembly. (See Fig. 6-3 to 6-5)
2. Detach 2 stop rings, release the tab, and remove ADF top cover assembly.

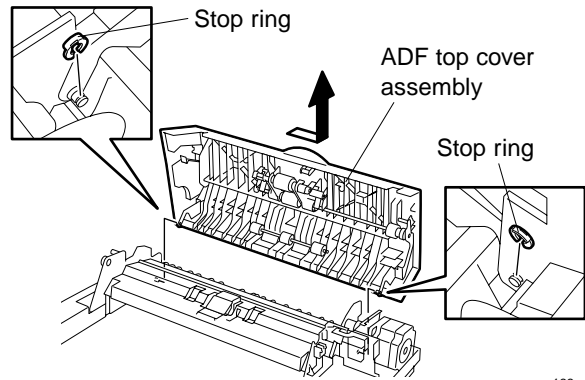

Fig. 6-9

168

**[F] ADF pickup roller assembly/ADF pickup roller/
ADF pickup feed roller**

1. Open ADF top cover. (See Fig. 6-3)
2. Remove 2 screws, and remove ADF document guide.

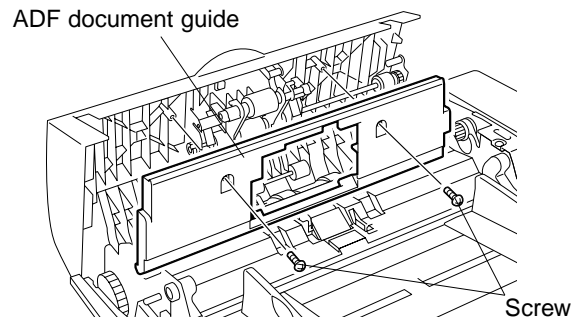

Fig. 6-10

169

3. Remove two each of stop ring and bushing and remove ADF pickup roller assembly.

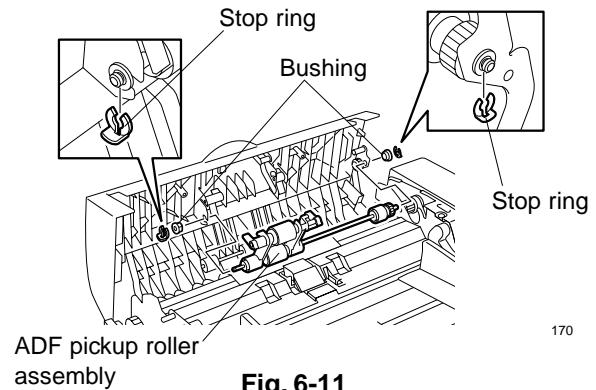

Fig. 6-11

170

4. Detach 2 stop rings and remove shutter stopper.
5. Slide ADF holder F in the direction of the arrow and draw out pin.

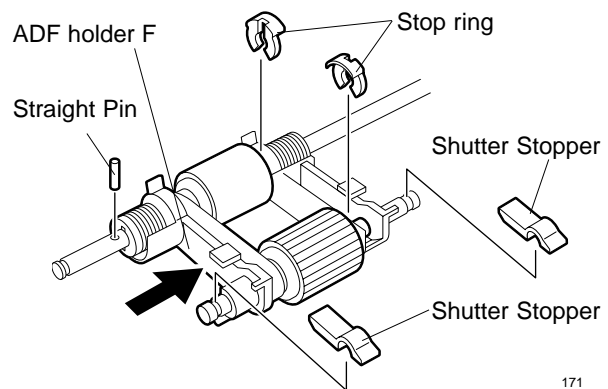
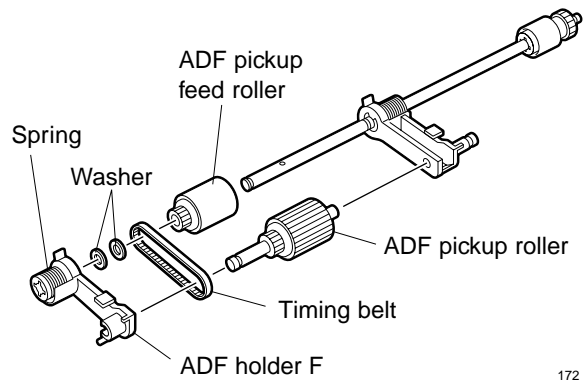

Fig. 6-12

171

- Remove Spring, ADF holder F, and washers in this order, and remove timing belt.
- Remove ADF pickup roller and ADF pickup feed roller.

Note: Apply 0.1g of Sumitec 505 No. 1 (white) to the outer circumference of the spring.



172

Fig. 6-13

[G] ADF pad/brake pad

- Open ADF top cover. (See Fig. 6-3)
- Release the hook and remove ADF pad unit.

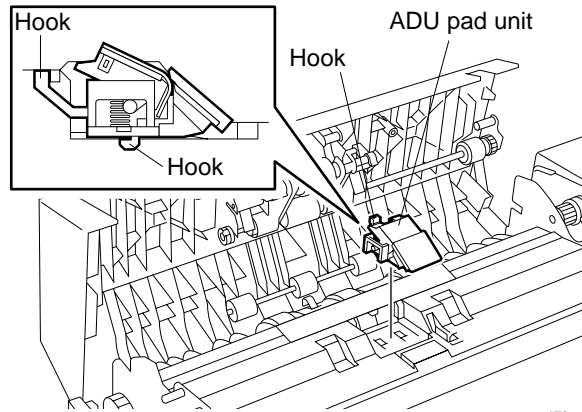

173

Fig. 6-14

- Release the tab and remove ADF pad.

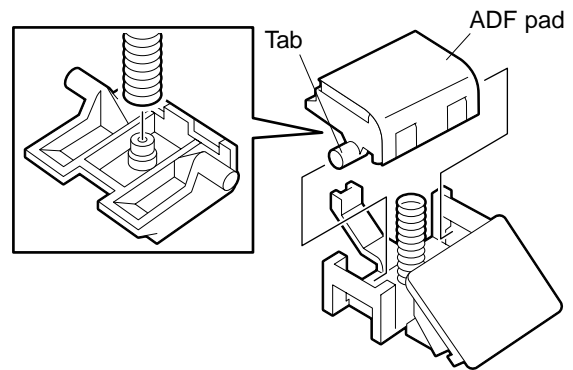

174

Fig. 6-15

- Remove the old brake pad, wipe off the mounting surface, and mount a new brake pad to the position shown below.

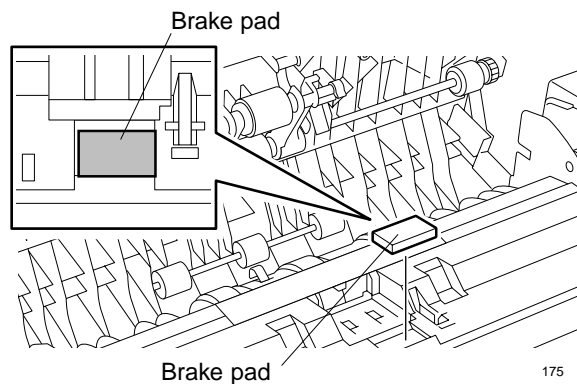

175

Fig. 6-16

[H] ADF PWA

1. Open ADF top cover. (See Fig. 6-3)
2. Remove one screw, release 3 hooks, and detach ADF cover R.

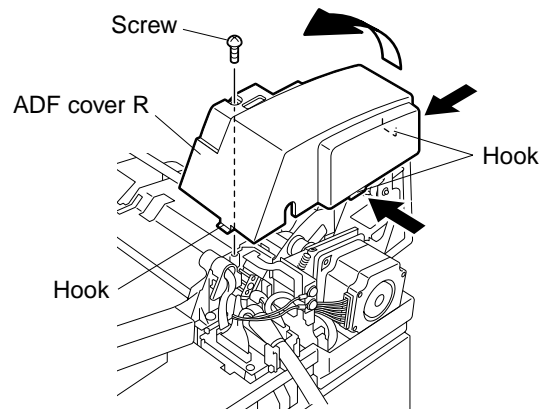

Fig. 6-17

176

3. Detach all the connectors from ADF PWA.
4. Remove 2 screws and remove ADF PWA.

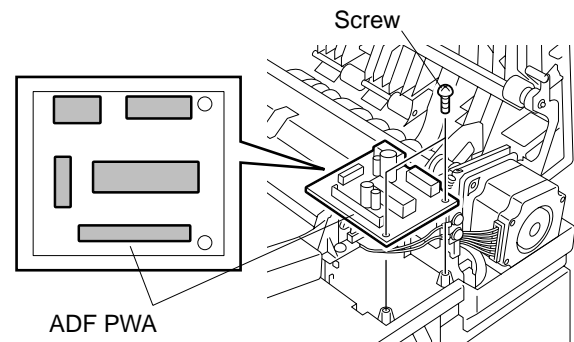

Fig. 6-18

177-1

[I] ADF feed guide assembly

1. Remove document tray assembly. (See Fig. 6-3 to 6-5)
2. Remove ADF top cover assembly. (See Fig. 6-9)
3. Detach the connectors from ADF PWA (CN2-CN4), remove one screw, and detach the ground wire.
4. Remove 4 screws, release 2 hooks, and remove ADF feed guide assembly.

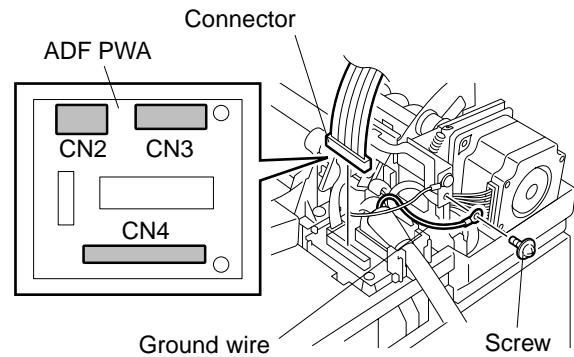

Fig. 6-19

177-2

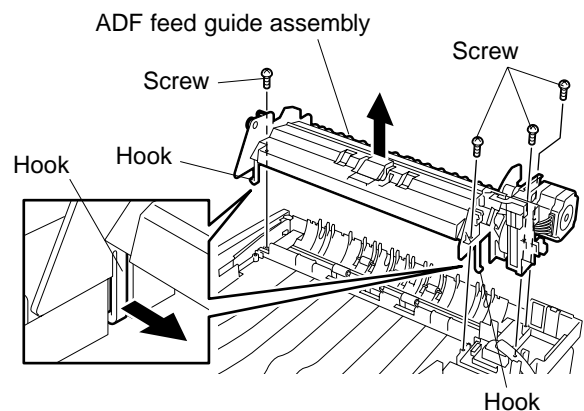

Fig.6-20

178

Note: Mount ADF feed guide assembly with mylar on exit pinch roller up.

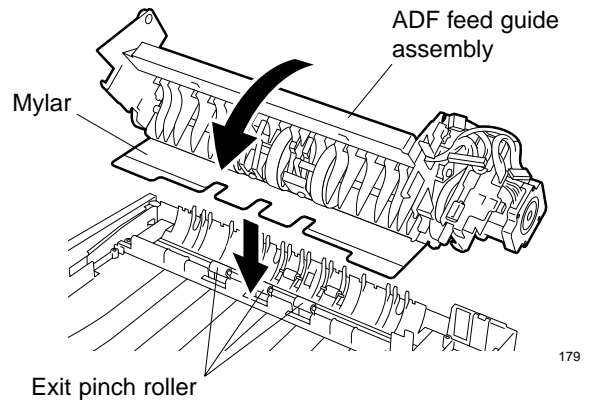

Fig. 6-21

[J] ADF feed motor assembly

1. Remove document tray assembly. (See Fig. 6-3 to 6-5)
2. Remove ADF top cover assembly. (See Fig. 6-9)
3. Remove ADF feed guide assembly. (See Fig. 6-19 and 6-20)
4. Detach one connector from platen sensor, and release the harness of ADF feed motor assembly from the clamp.
5. Remove one screw and detach the ground wire.
6. Remove 3 screws, release timing belt 166, and remove ADF feed motor assembly.
7. Remove tension spring 2.

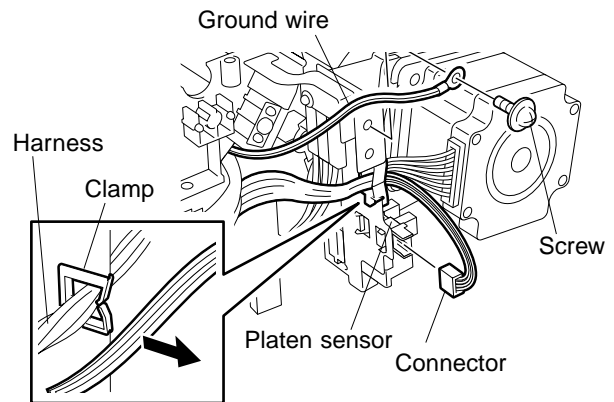

Fig. 6-22

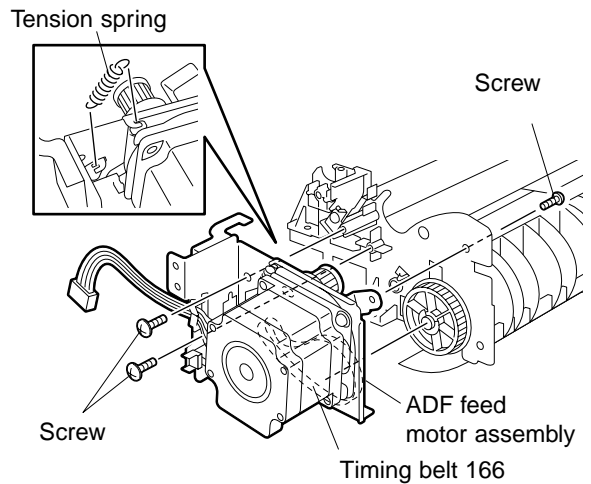

Fig. 6-23

Notes: Installation procedure for timing belt 166

1. While hooking timing belt 166 around feed pulley M-66, secure ADF feed motor assembly with 2 screws.

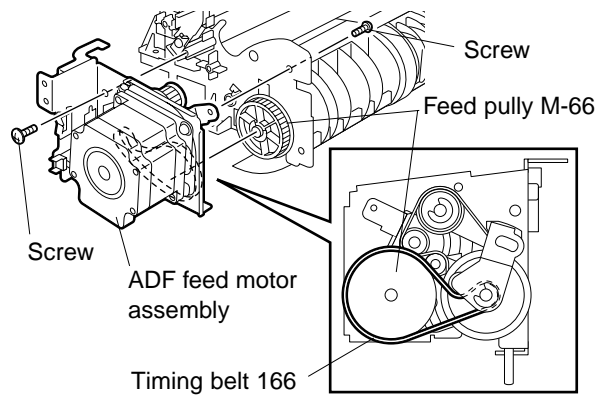

Fig. 6-24

2. Mount tension spring 2 and secure the belt bracket 2 with one screw.

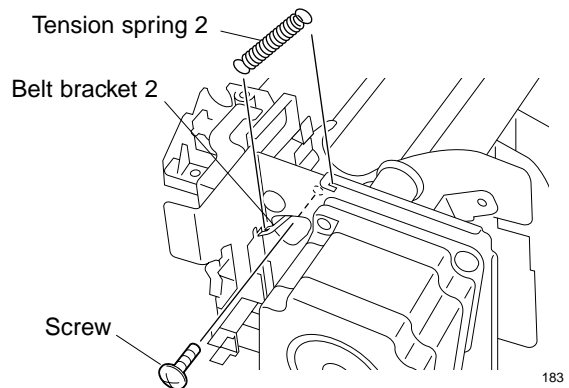

Fig. 6-25

[K] Read roller shaft assembly/ Read roller shaft

1. Remove document tray assembly.
(See Fig. 6-3 to 6-5)
2. Remove ADF top cover assembly.
(See Fig. 6-9)
3. Remove ADF feed guide assembly.
(See Fig. 6-19 and 6-20)
4. Remove ADF feed motor assembly.
(See Fig. 6-22 and 6-23)
5. Remove one screw, release 2 hooks, and detach sensor cover R.

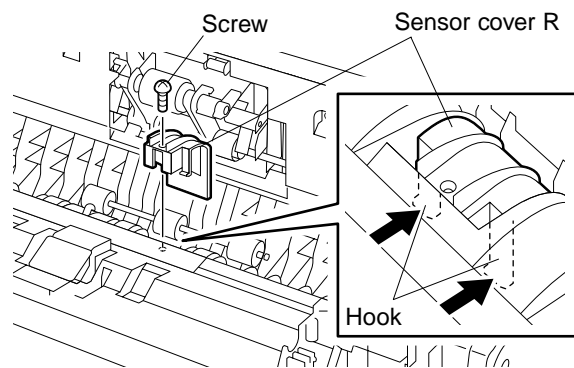

Fig. 6-26

- Remove one screw and remove exit plate.

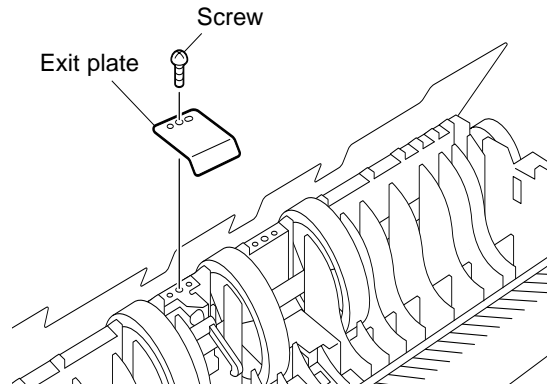

Fig. 6-27

185

- Release 4 hooks and detach harness cover.

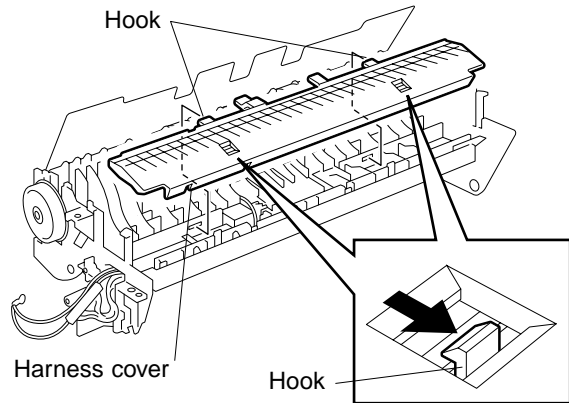

Fig. 6-28

186

- Remove one screw and remove the ground wire and ADF registration sensor bracket.

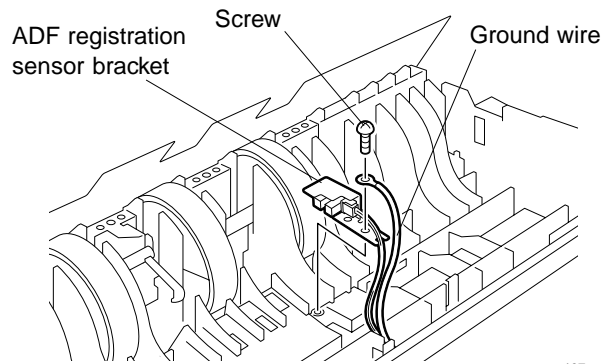

Fig. 6-29

187

- Remove one screw and remove the ground wire and ADF exit/read sensor bracket while pushing the part indicated by the arrow.

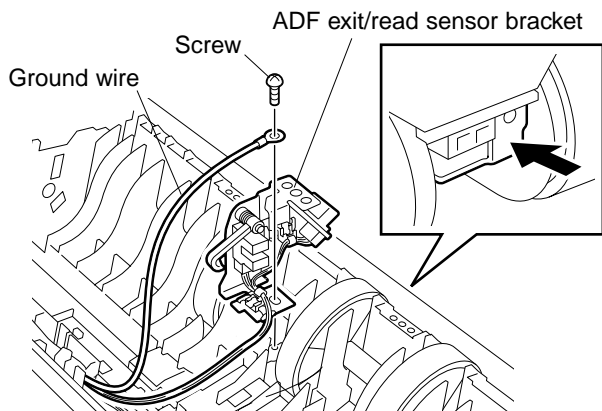
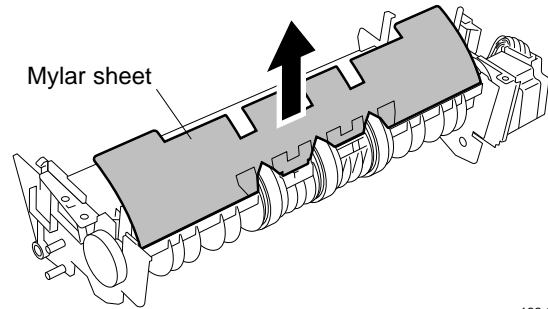

Fig. 6-30

188-1

10. Remove the mylar sheet.



188-2

Fig. 6-31

Note: Before attaching the mylar sheet, wipe the surface to be attached. Attach the mylar sheet by holding it to the two ends. Attach the sheet securely with no portion lifted.

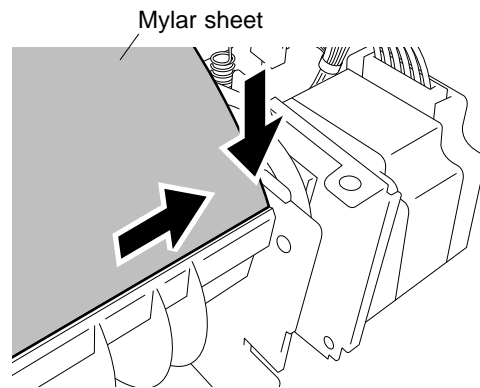

188-3

Fig. 6-32

11. Detach the E-ring and remove feed pulley M-66.

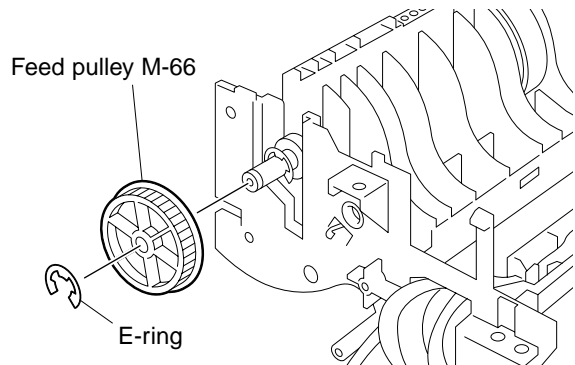

189

Fig. 6-33

12. Detach the E-ring, slide bearing inwards, and remove Read roller shaft assembly.

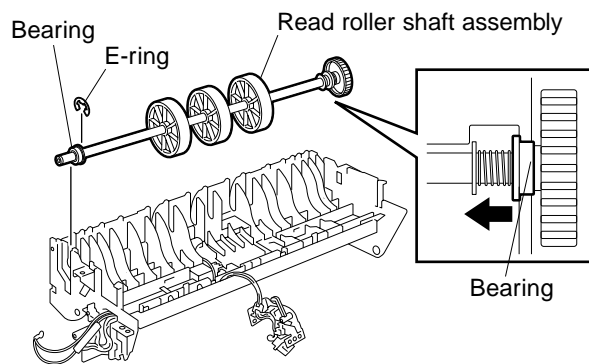

190

Fig. 6-34

13. Detach the E-ring from Read roller shaft and remove bearing.
14. Detach ADF knob from Read roller shaft and remove bearing and spring.

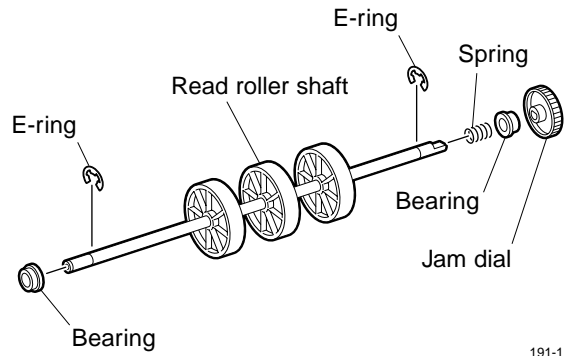

191-1

Fig. 6-35

[L] ADF front cover

1. Open ADF unit.
2. Release 3 screws and hook and detach ADF front cover by sliding it in the direction of the arrow.

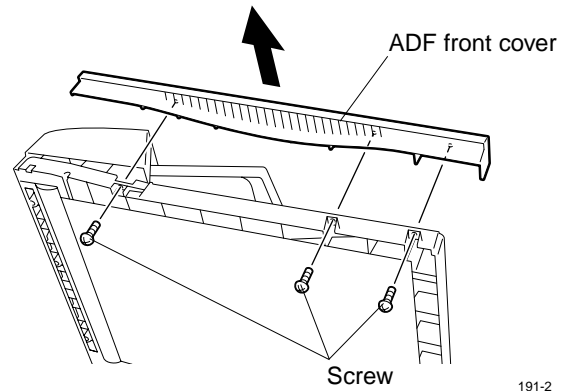

191-2

Fig. 6-36

TOSHIBA

TOSHIBA TEC CORPORATION

1-1, KANDA NISHIKI-CHO, CHIYODA-KU, TOKYO, 101-8842 JAPAN