

TOSHIBA

SERVICE MANUAL

STACK FEED BYPASS

MY-1016



General Precautions for Installation/Service/Maintenance for the MY-1016

The installation and service should be done by a qualified service technician.

1. When installing the MY-1016 to the Plain Paper Copier, be sure to follow the instructions described in the "Unpacking/Set-Up Procedure for the MY-1016" booklet which comes with each unit of the MY-1016.
2. The MY-1016 should be installed by an authorized/qualified person.
3. Before starting installation, servicing or maintenance work, be sure to turn off and unplug the copier first.
4. When servicing or maintaining the MY-1016, be careful about the rotating or operation sections such as gear, pulleys, sprockets, cams, belts, etc.
5. When parts are disassembled, reassembly is basically the reverse of disassembly unless otherwise noted in this manual or other related materials. Be careful not to reassemble small parts such as screws, washers, pins, E-rings, toothed washers to the wrong places.
6. Basically, the machine should not be operated with any parts removed or disassembled.
7. Delicate parts for preventing safety hazard problems (such as breakers, thermofuses, fuses, door switches, sensors, etc. if any) should be handled/installed/adjusted correctly.
8. Use suitable measuring instruments and tools.
9. During servicing or maintenance work, be sure to check the serial No. plate and other cautionary labels (if any) to see if they are clean and firmly fixed. If not, take appropriate actions.
10. The PC board must be stored in an anti-electrostatic bag and handled carefully using a wristband, because the ICs on it may be damaged due to static electricity. Before using the wrist band, pull out the power cord plug of the copier and make sure that there is no uninsulated charged objects in the vicinity.
11. For the recovery and disposal of used MY-1016, consumable parts and packing materials, it is recommended that the relevant local regulations/rules should be followed.
12. After completing installation, servicing and maintenance of the MY-1016, return the MY-1016 to its original state, and check operation.

Copyright 2000

TOSHIBA TEC CORPORATION

CONTENTS

1. SPECIFICATIONS	1-1
2. OUTLINE	2-1
2.1 Names of Various Components	2-1
2.2 Layout of Electrical Parts	2-2
2.3 Harness Connection Diagram	2-3
3. OPERATIONAL DESCRIPTION.....	3-1
3.1 General Operation	3-1
3.2 Block Diagram	3-1
3.3 Detection of Abnormal Status	3-2
3.3.1 Paper jam detection	3-2
3.4 Flow Charts	3-3
4. MECHANICAL DESCRIPTION.....	4-1
4.1 Paper Feed System	4-1
4.2 Drive System	4-2
5. CIRCUIT DESCRIPTION	5-1
5.1 Meaning of Signals	5-1
5.2 Timing Chart	5-2
6. DISASSEMBLY AND REPLACEMENT.....	6-1

1. SPECIFICATIONS

Function	: Pickup roller drop and paper feed roller method
Paper	: Continuous feed 64 to 80g/m ² (17 to 21 lbs) : Single sheet feed 80 to 163g/m ² (21 to 43 lbs)
Transport speed	: 260 mm/sec.
Max. capacity	: 11 mm (100 sheets)
Dimensions	: 120 (W) x 485 (D) x 227 (H) mm
Weight	: Approx. 2.5 kg
Power supply	: 5VDC, 24VDC (Supplied from copier)

2. OUTLINE

2.1 Names of Various Components

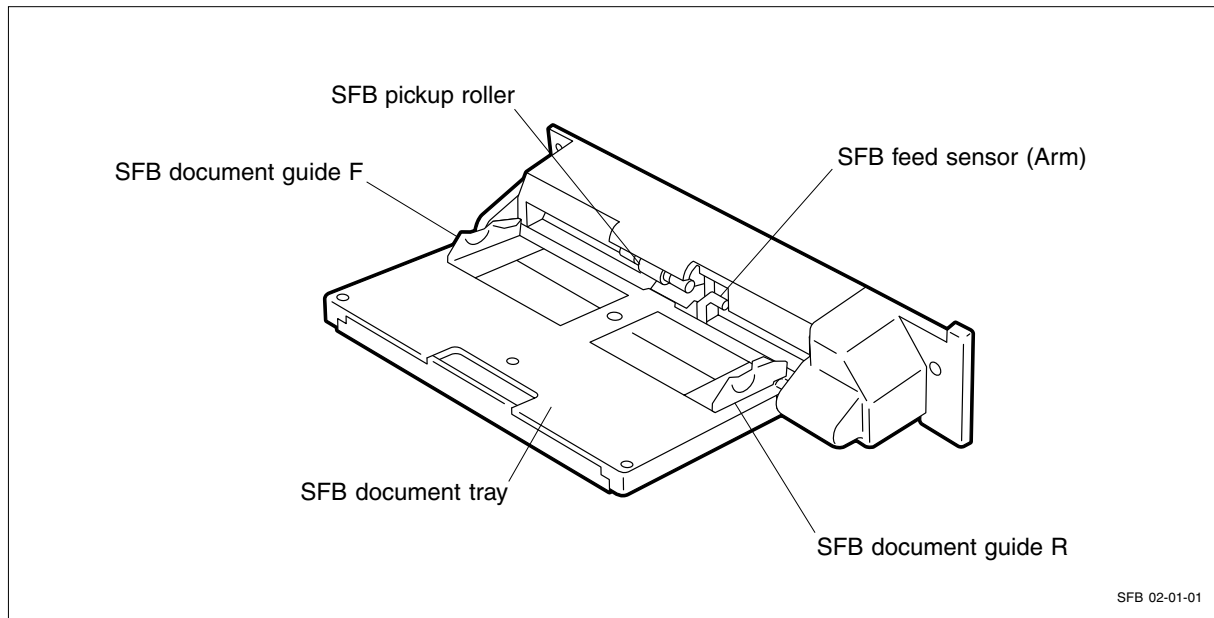

2.2 Layout of Electrical Parts

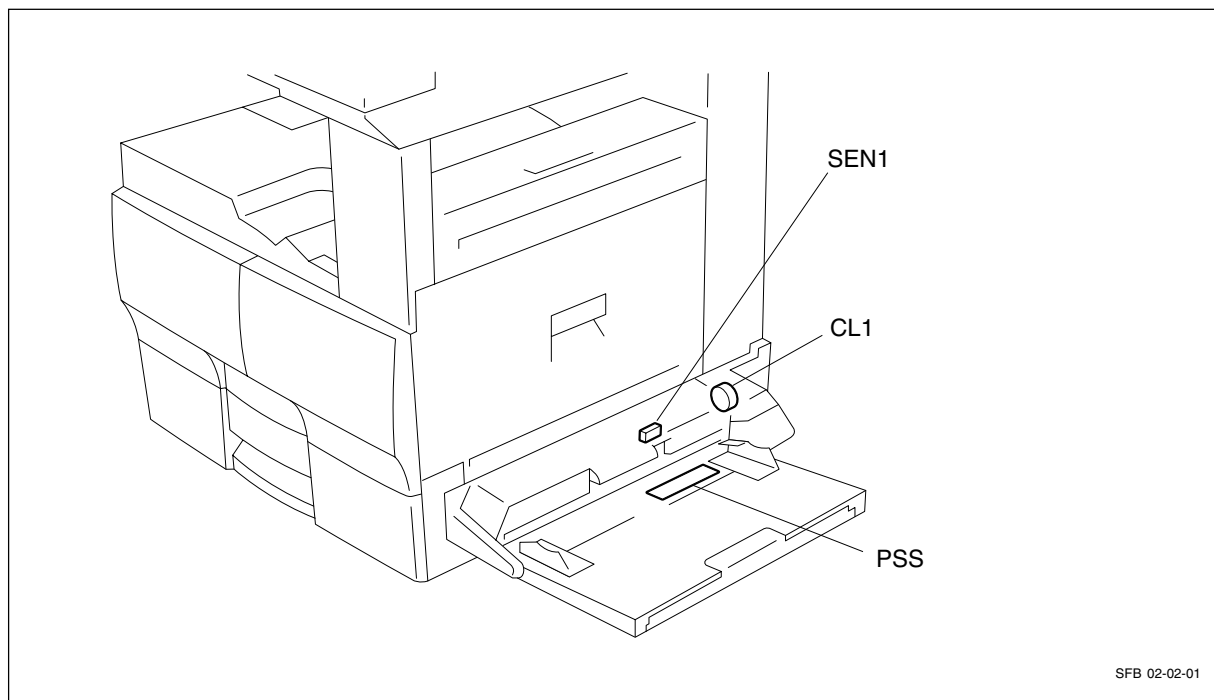

SFB 02-02-01

Symbols and functions of various devices

Symbol	Name	Function
SEN1	SET-SEN SFB feed sensor	Detects the loading of paper.
CL1	MPU-CLT SFB clutch	Transmits driving force to the rollers to pick up and transport the paper.
PSS	PSS-PWA SFB paper size sensor	Paper size detection.

2.3 Harness Connection Diagram

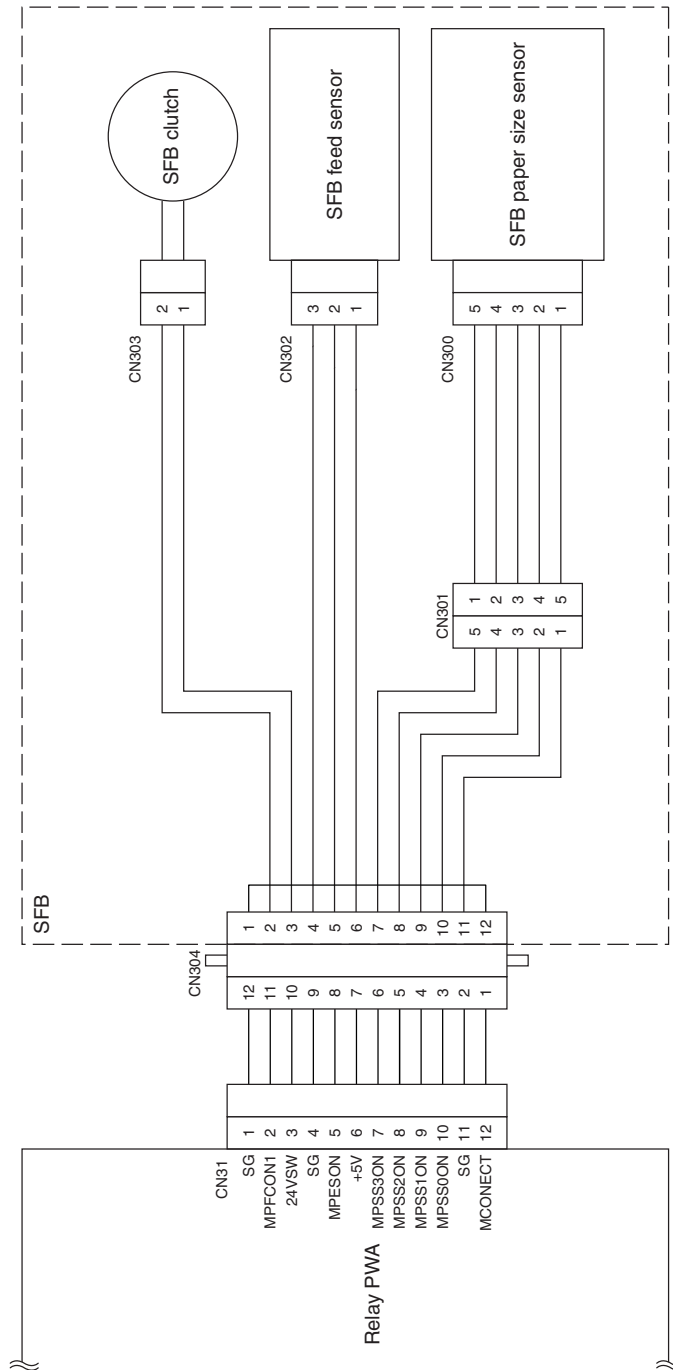

SFB 02-03-01

3. OPERATIONAL DESCRIPTION

3.1 General Operation

The SFB is a bypass feed unit mounted on the right side of the copier. This unit has no PWA and the operation and detection signals are sent to the MAIN PWA through the RELAY PWA. The unit is controlled by the MAIN PWA.

3.2 Block Diagram

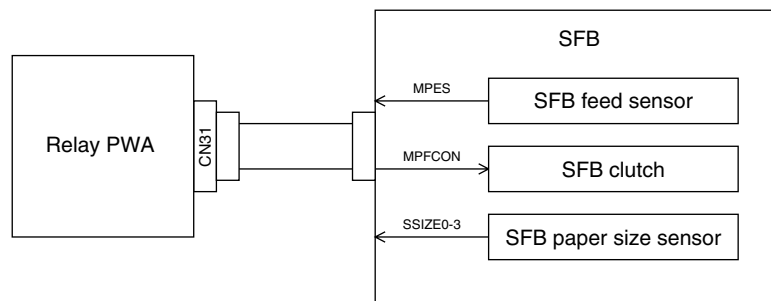

SFB 03-02-01

The SFB consists of the one switch, one magnetic clutch, and paper size sensor. These signals connect to the MAIN PWA through the relay cable and RELAY PWA. When the bypass feed is selected on the copier side and paper is placed in the SFB, printing by the bypass feed is enabled.

3.3 Detection of Abnormal Status

3.3.1 Paper jam detection

The SFB has the SFB feed sensor to detect that the paper has been placed. When you press the Start key on the copier after this sensor detects the presence of paper, the SFB clutch turns ON to start feeding. If the paper has not reached the feed sensor on the copier side for a fixed time after feeding begins, the program will judge it to be paper jamming and stop feeding. To reset the error state, once remove the paper and turn the SFB feed sensor OFF.

3.4 Flow Charts

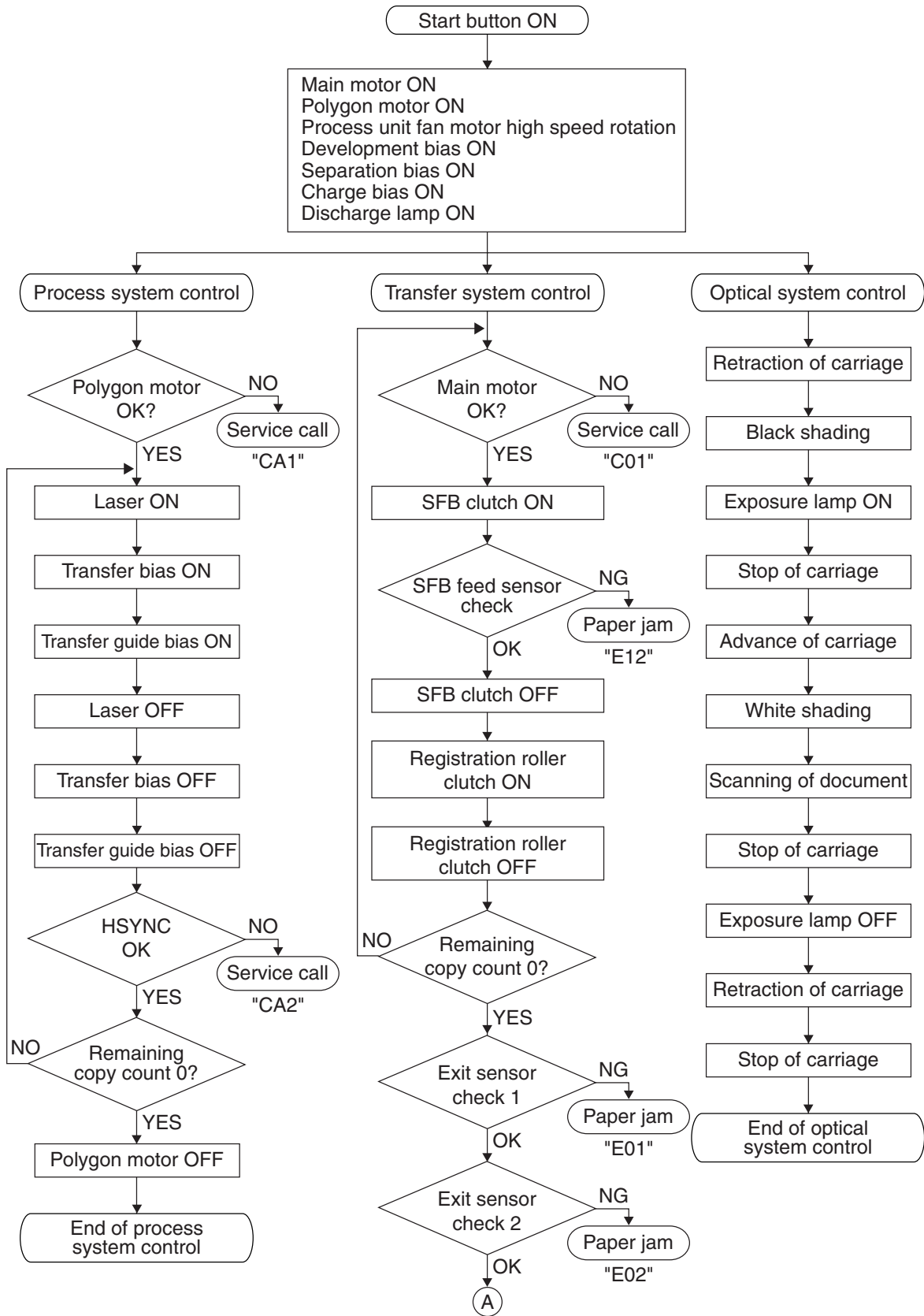

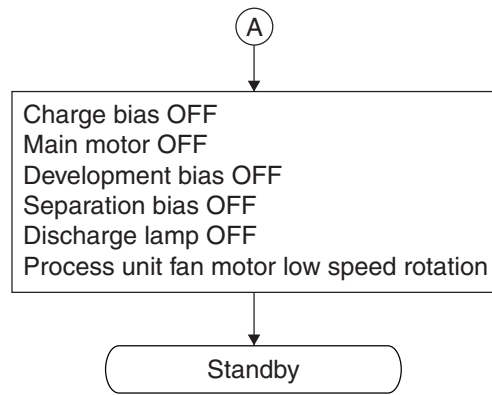

4. MECHANICAL DESCRIPTION

4.1 Paper Feed System

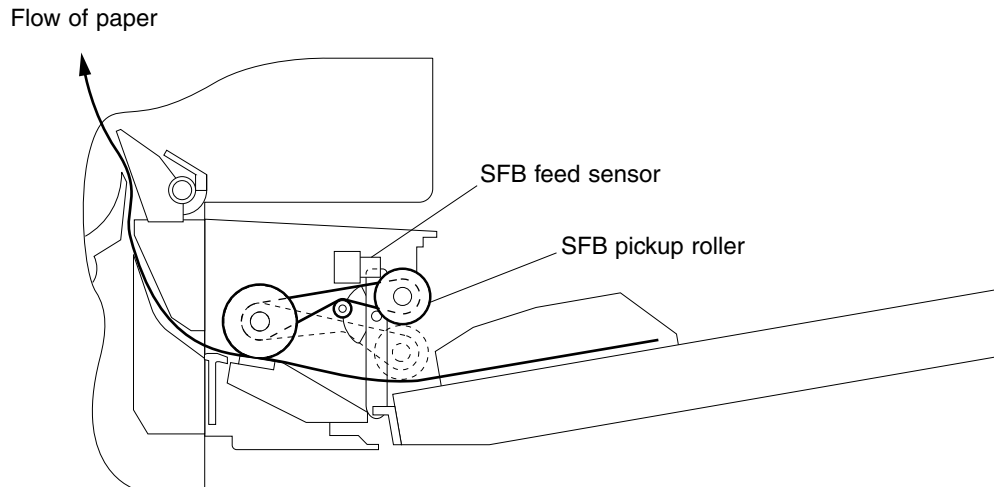

SFB 04-01-01

Paper Pickup Operation

When you place the paper, the arm of the SFB feed sensor is pushed in causing the sensor to turn ON (paper present). When you press the Start button on the copier to turn the gear on the copier side, the gear of the SFB also turns and the SFB clutch turns ON, causing the SFB pickup roller to lower and pull in the paper.

4.2 Drive System

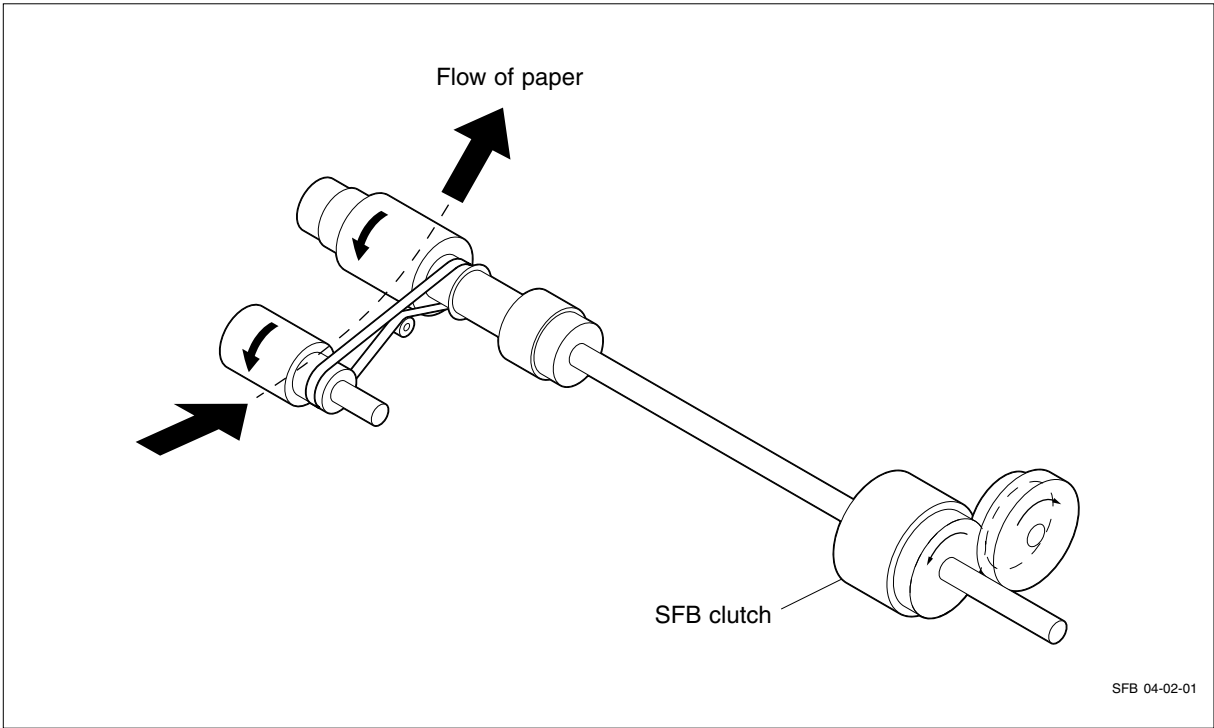

The SFB is driven from the copier through the gear. When the SFB clutch turns ON, the rotation on the copier side is transmitted to the SFB feed roller. The SFB pickup roller is connected to the SFB feed roller through the belt. When the SFB feed roller turns, the SFB pickup roller lowers and starts picking up. When the paper is pulled in, the SFB clutch turns OFF and the SFB pickup roller returns to its original position.

5. CIRCUIT DESCRIPTION

5.1 Meaning of Signals

Signal name	Part name	Functional description	Status	Note
MPESON	SFB feed sensor	Detects the loading of paper		Photo sensor
MPFCON	SFB clutch	Transmits driving force to the rollers to pick up and transport the paper	Low: ON	Magnetic clutch
MPSS 0-3 ON	SFB paper size sensor	Paper size detection	Low: Detection	PWA pattern

The SFB feed sensor is a photo sensor which detects that the paper has been placed in the bypass tray. The signal is usually at "High" level (no paper present) and goes LOW when the paper is placed. This signal is sent to the MAIN PWA through the relay cable and RELAY PWA.

SFB clutch is an operation signal for the clutch to transmit driving from the copier to the SFB. The signal output from IC36 (MFPCON) on the MAIN PWA connects to the transistor (Q16) on the RELAY PWA. When the signal is at "High" level, Q16 turns ON to drive the clutch, causing the pickup roller to lower and pull in the paper.

The SFB paper size sensor detects the width of the paper placed in the tray of the SFB. The brush attached to the paper width guide is touching the pattern on the PWA, and one of the MPSS0 - 3 signals is detected according to the position to which the paper width guide is slid. MPSS0 goes LOW at the narrowest position, and MPSS3 at the widest position. (When each width sensor is at "Low" level, that width is detected.) Since the detection areas overlap as shown below, two signals may be detected at the same time depending on the position of the paper width guide

A4 Series	LT Series	MPSS 0	MPSS 1	MPSS 2	MPSS 3
A4	LT	H	H	H	L
A4-R	LT-R	H	H	L	H
A5-R	ST-R	H	L	H	H
A6	-	L	L	H	H
B4	COMP	H	H	L	L
B5-R	-	H	L	L	H
B6	-	L	L	H	H

5.2 Timing Chart

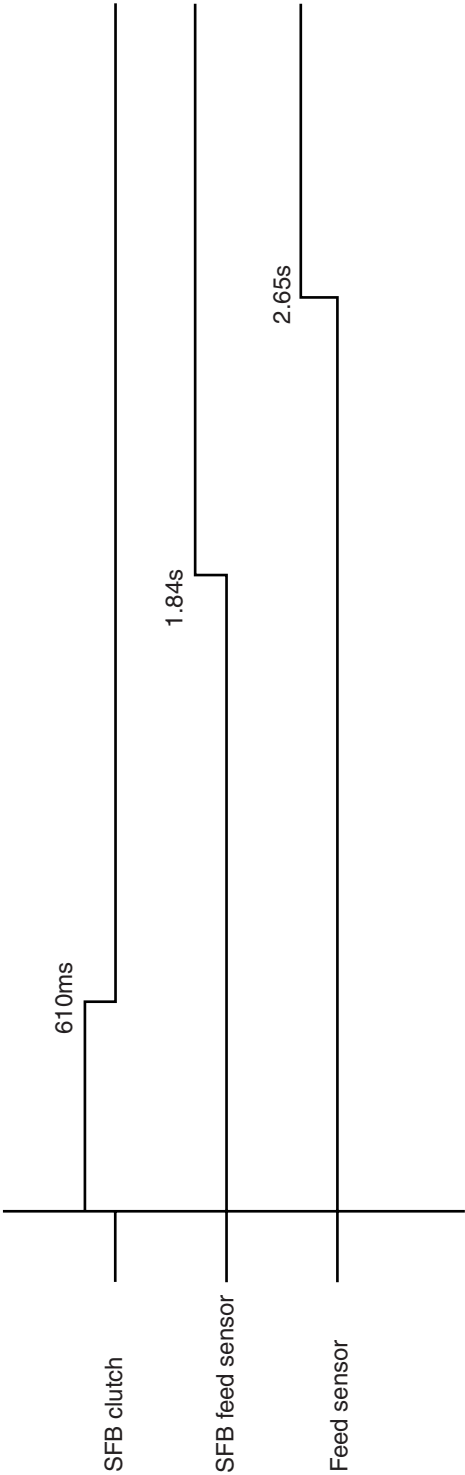

The values are data (reference values) applicable when the A4 size paper is used.

6. DISASSEMBLY AND REPLACEMENT

[A] SFB assembly/SFB cover

1. Remove 2 screws and detach SFB cover.

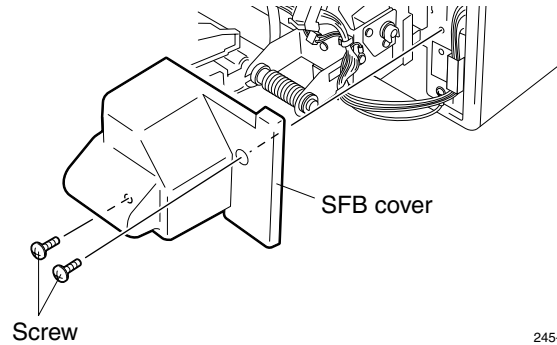

Fig. 6-1

245-1

2. Remove one screw and detach harness fixing plate.
3. Detach one connector, remove one screw, and detach the ground wire.

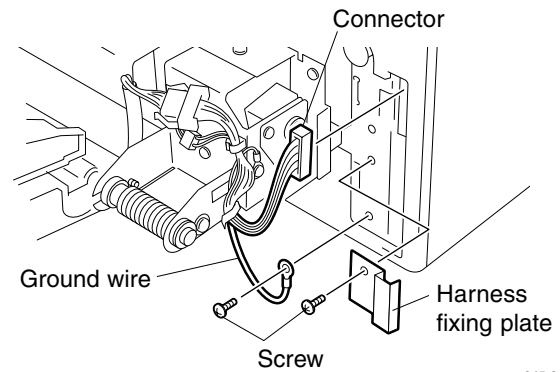

Fig. 6-2

245-2

4. Remove 2 screws, release 2 hooks, and remove SFB assembly.

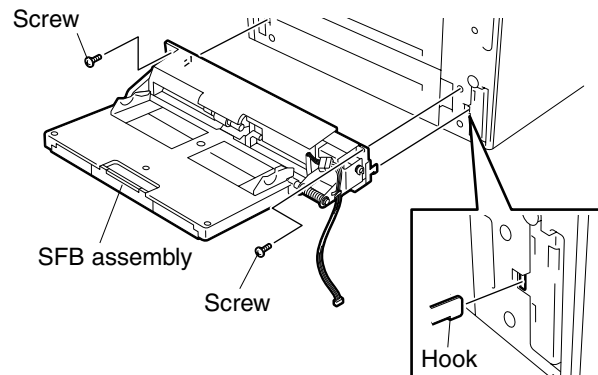

Fig. 6-3

246

[B] SFB hinge unit

1. Remove SFB cover. (See Fig. 6-1)
2. Release one clamp and detach the harness.
3. Remove 2 screws, slide SFB hinge unit in the direction of the arrow, release one hook, and remove SFB hinge unit.

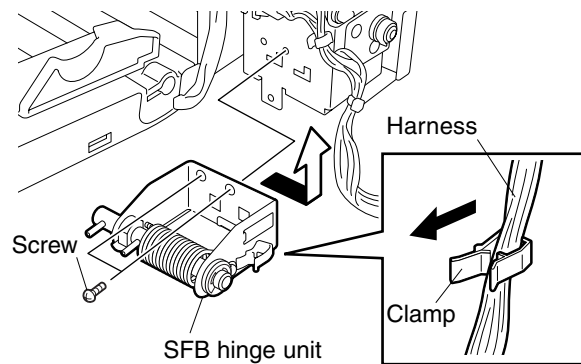

Fig. 6-4

247

Notes: For installation, follow the procedure described below.

- 1 Insert SFB hinge shaft into SFB document tray assembly.
- 2 Turn SFB hinge unit by 180 degrees, hook it to SFB, and fix it with 2 screws.

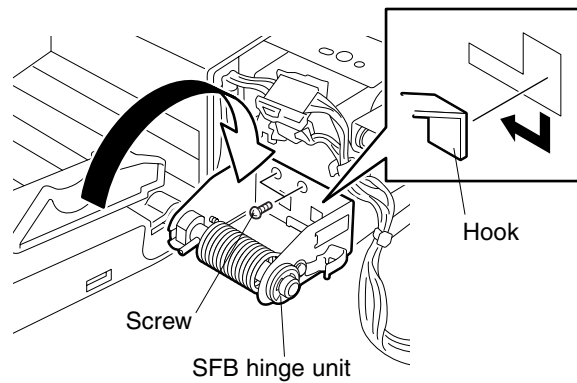

Fig. 6-5

248

[C] SFB document tray assembly

1. Remove SFB cover. (See Fig. 6-1)
2. Detach one connector and release 2 clamps.
3. Remove SFB hinge unit. (See Fig. 6-4)
4. Release the stud and remove SFB document tray assembly.

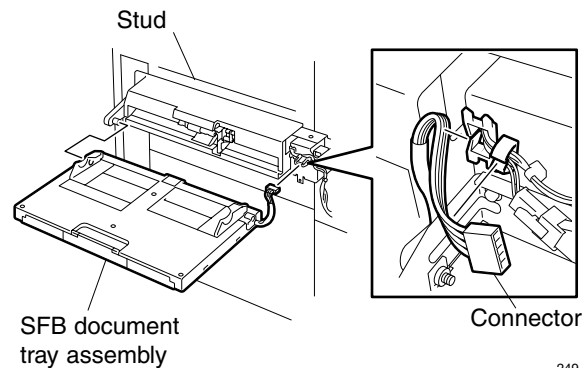

Fig. 6-6

249

**[D] SFB document tray upper/SFB document tray lower/
SFB document tray support/SFB PWA plate/
SFB document guide flange**

1. Remove SFB document tray assembly.
(See Fig. 6-6)
2. Remove 3 screws, release 7 hooks, and detach SFB document tray upper.
3. Remove SFB document tray support.
4. Release 4 hooks and detach the SFB document tray 2nd support.

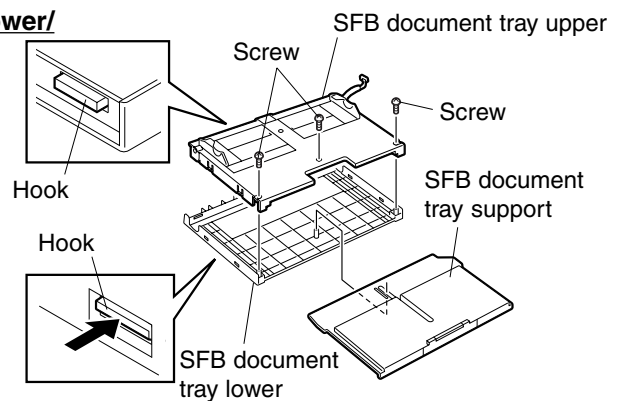

Fig. 6-7

250-1

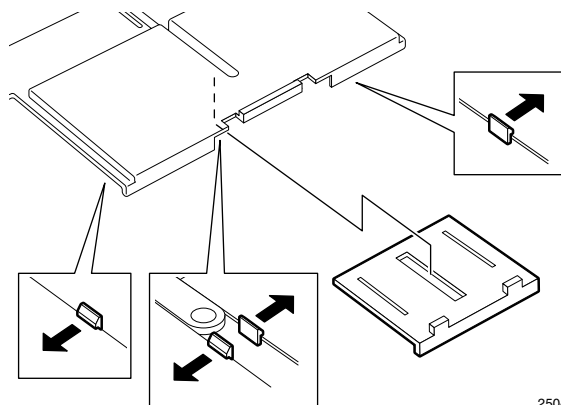

Fig. 6-8

250-2

5. Remove one screw and remove SFB pinion plate.
6. Remove one screw and remove SFB PWA plate.
7. Remove SFB document guide flange.

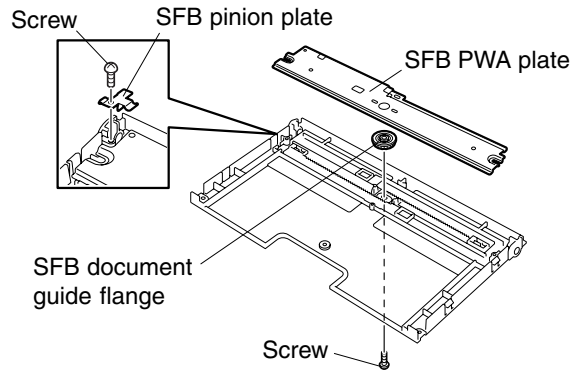

Fig. 6-9

250-3

- Notes:**
1. Put 0.2 grams of silicon oil (TSF451) on the side of the guide rail.
Never put silicon oil on the paper feed side.
 2. Put 0.05 grams of silicon oil (TSF451) inside the SFB document guide rack.

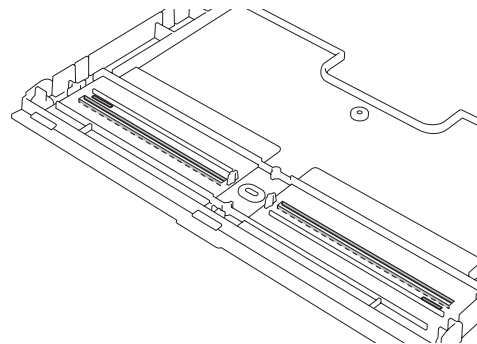

Fig. 6-10

250-5

- Note:** Set SFB document guide flange so that the convexity of SFB PWA plate is positioned as shown right when SFB PWA plate is mounted.

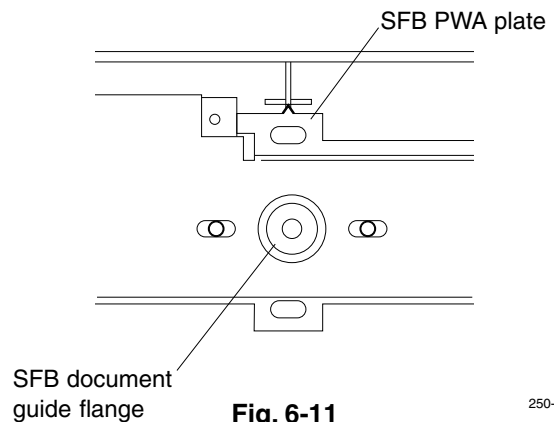

Fig. 6-11

250-4

[E] SFB cover/SFB brake pad assembly

1. Remove SFB hinge unit. (See Fig. 6-1 to 6-4)
2. Remove SFB document tray assembly. (See Fig. 6-6)
3. Remove 4 screws, release 2 tabs, and remove SFB brake pad assembly.

- Note:** For reassembly, mount the screws in the order shown right.

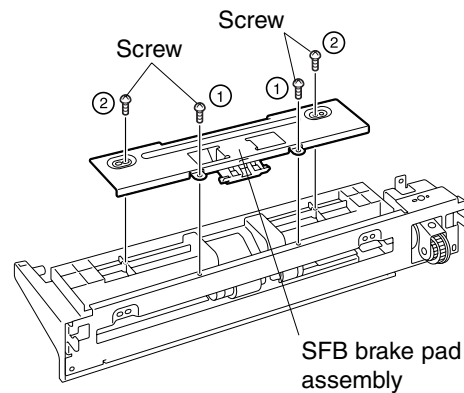

Fig. 6-12

251

4. Release SFB pad spring and remove SFB brake.

Note: Clean the SFB brake pad with a cloth moistened with alcohol by pressing hard, and going back and forth on the brake pad more than 20 times.

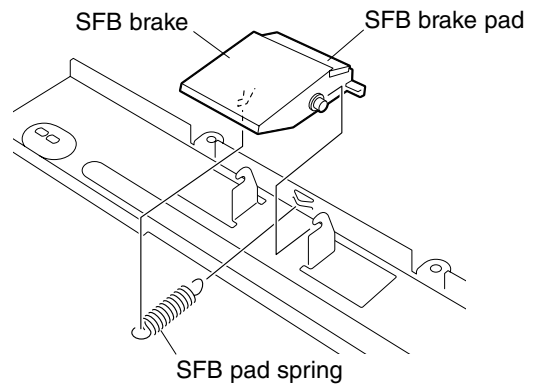

Fig. 6-13

252

5. Remove 2 screws, release 2 tabs, and detach SFB feed cover.

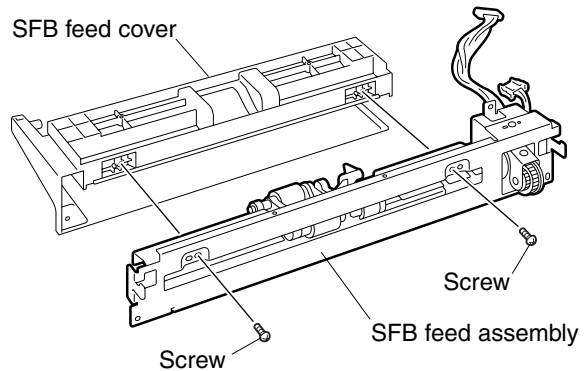

Fig. 6-14

253

[F] SFB clutch pulley/SFB flange wheel

1. Remove SFB hinge unit. (See Fig. 6-1 to 6-4)
2. Remove SFB document tray assembly. (See Fig. 6-6)
3. Detach SFB feed cover. (See Fig. 6-12 and 6-14)
4. Detach stop ring and remove bushing.
5. Release 3 clamps and detach the harness.
6. Remove one screw and detach the ground wire.

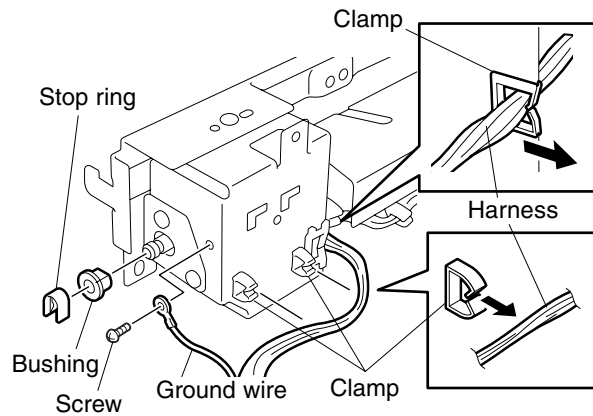

Fig. 6-15

254

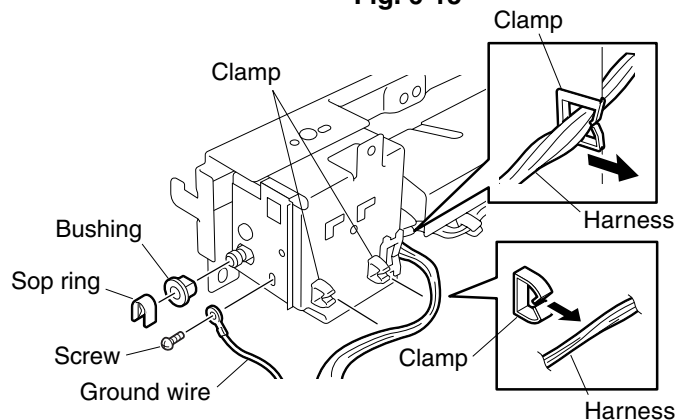

Fig. 6-15-1

254-1

- Remove 2 screws, release 2 tabs, slide SFB feed roller assembly in the direction of the arrow, and remove SFB clutch pulley assembly.

Notes: 1. SFB feed roller fixing plate type

Before attaching the SFB feed roller assembly, loosen 2 screws securing the SFB feed roller fixing plate. Attach the SFB brake pad assembly (See Fig.6-12), then fix the SFB feed roller fixing plate in place.

2. SFB feed roller adjusting plate type

Attach the SFB feed roller adjusting plate so that the edge of the tray holder is placed at a center of the marking.

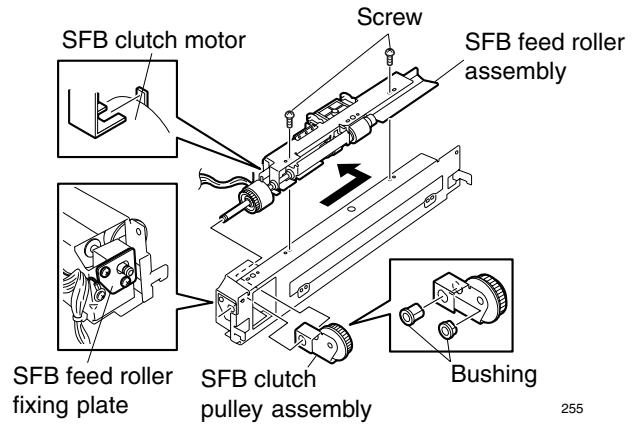

Fig. 6-16

255

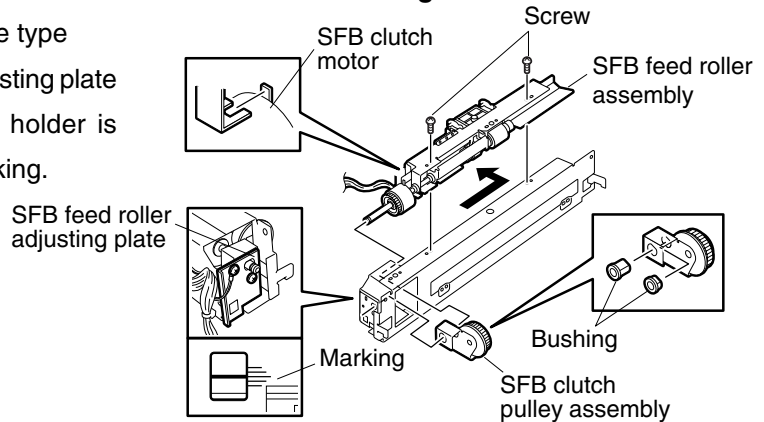

Fig. 6-16-1

255-1

[G] SFB feed roller shaft assembly

- Remove SFB hinge unit. (See Fig. 6-1 to 6-4)
- Remove SFB document tray assembly. (See Fig. 6-6)
- Detach SFB feed cover. (See Fig. 6-12 and 6-14)
- Remove SFB feed roller assembly. (See Fig. 6-15 to 6-16-1)
- Detach one connector, loosen one screw, and remove SFB clutch motor.

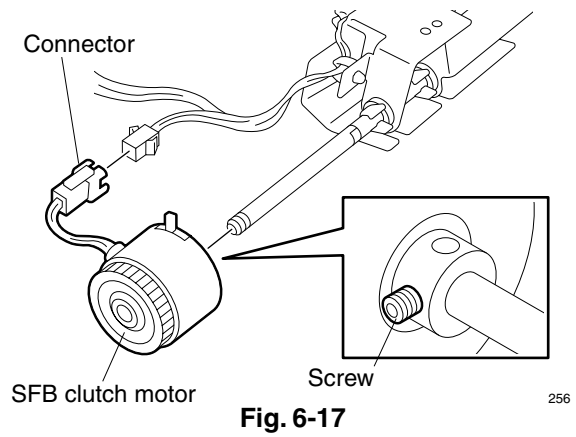

Fig. 6-17

256

- Remove one screw and remove guide plate R.

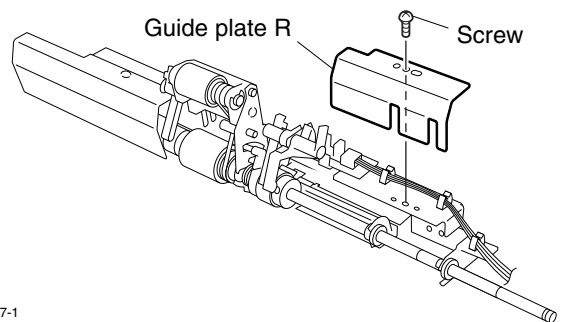

Fig. 6-18

257-1

7. Remove one screw and remove roller bracket.
8. Detach E-ring and remove bushing.
(SFB feed roller fixing plate type)
9. Remove SFB feed roller shaft assembly.

Note: Be sure to attach the spring when attaching the SFB feed roller shaft assembly.

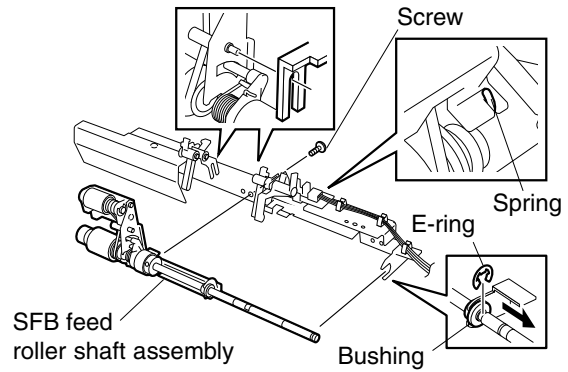

Fig. 6-19

257-2

[H] SFB feed roller

1. Remove SFB assembly. (See Fig. 6-1 to 6-3)
2. Remove the screw and detach the guide plate F.

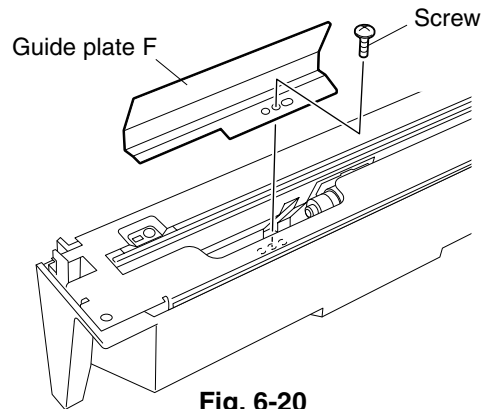

Fig. 6-20

258

3. Detach stop ring, and remove clutch and SFB feed roller.

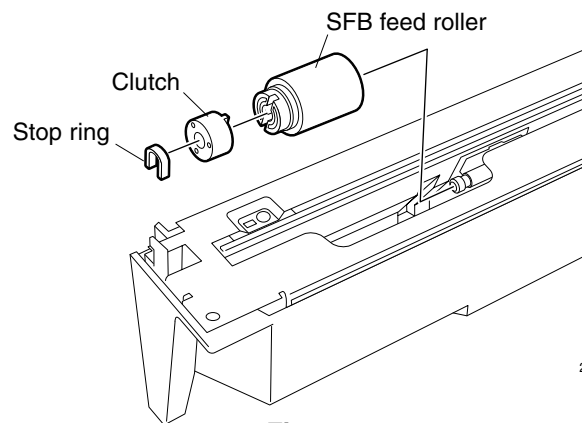

Fig. 6-21

259

[I] SFB pickup roller

1. Remove the stop ring and take out the pickup roller shaft.
2. Detach the pickup roller by releasing the timing belt 142.

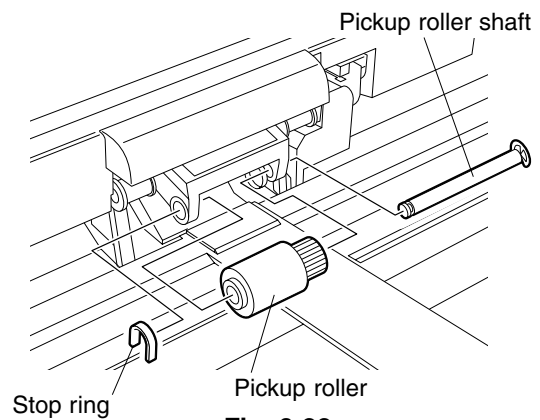

Fig. 6-22

260

TOSHIBA

TOSHIBA TEC CORPORATION

1-1, KANDA NISHIKI-CHO, CHIYODA-KU, TOKYO, 101-8842 JAPAN