

**TOSHIBA**

**SERVICE SUPPORT GUIDE**  
**DIGITAL PLAIN PAPER COPIER**

**e-STUDIO0550/650/810**

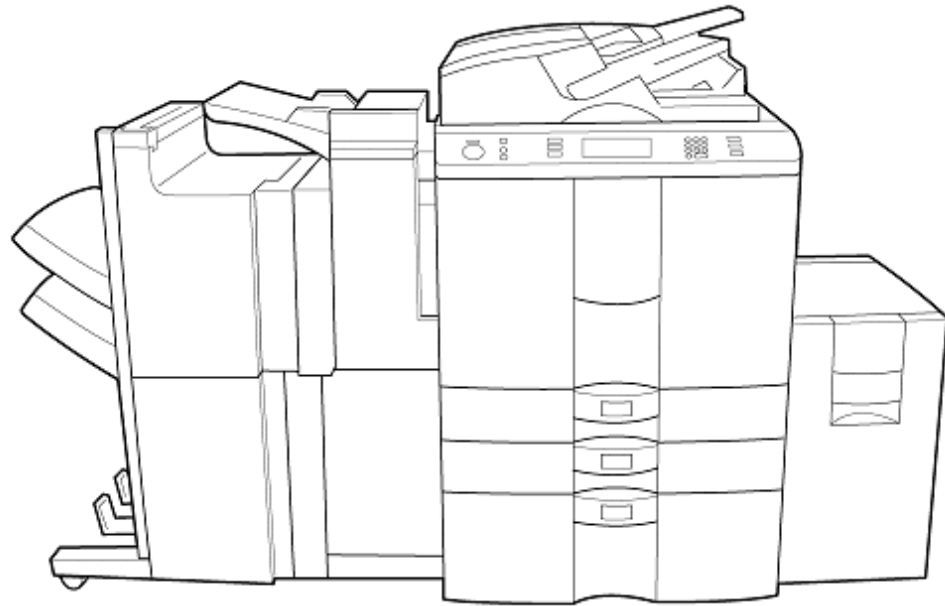

SSE02000100

**Trademarks described in this guide:**

- The official name of Windows 95 is Microsoft Windows 95 Operating System.
- The official name of Windows 98 is Microsoft Windows 98 Operating System.
- Microsoft, Windows, and the brand names and product names of other Microsoft products are trademarks or registered trademarks of US Microsoft Corporation in the US and other countries.
- Postscript and Postscript Logo are trademarks of Adobe Systems Incorporated.
- IBM PC/AT is a registered trademark of the US International Business Machine Corporation.
- Other company names and product names in this guide are the trademarks or registered trademarks of their respective companies.

No part of this BTA-dealer guide may be copied in whole or part without permission.

The contents of this guide may change without notification.

© 2002 TOSHIBA TEC CORPORATION

All Rights Reserved.

# CONTENTS

<b>1. Product Overview .....</b>	<b>1-1</b>
<b>2. Design Features .....</b>	<b>2-1</b>
A. Basic Features .....	2-1
B. Basic Features with Optional Controller .....	2-4
C. New Technology Introduction .....	2-5
<b>3. Configuration.....</b>	<b>3-1</b>
A. System Configuration.....	3-1
B. Copy Paper Configuration.....	3-2
C. Original Configuration .....	3-3
D. e-STUDIO550/650/810 .....	3-4
E. Accessories.....	3-5
F. Options.....	3-6
G. Accessories for Options .....	3-7
Finisher (MJ-1017/1018).....	3-7
Hole punch unit (MJ-6003N/E/F/S).....	3-7
Inserter (MJ-7001) .....	3-7
Finisher guide rail (KN-1017).....	3-8
Large capacity feeder (MP-4003L/A).....	3-8
Damp heater kit (MF-6510U/E).....	3-8
Network printer board (GA-1140) .....	3-8
Expansion memory (GC-1080).....	3-9
PS3 upgrade (GE-1020).....	3-9
PS3 & HDD upgrade (GE-1060).....	3-9
Scan accelerator (GE-1110).....	3-9
DocBuilder Pro (GB-1060).....	3-9
DSS controller (GL-1020/1020E).....	3-10
H. Replacement Units.....	3-11
I. Supplies.....	3-11
<b>4. Specifications.....</b>	<b>4-1</b>
A. e-STUDIO550/650/810 .....	4-1
Continuous copying speed .....	4-3
B. Options.....	4-4
Finishers (MJ-1017/1018).....	4-4
Staple cartridge (STAPLE-600/700).....	4-5
Hole punch unit (MJ-6003N/E/F/S).....	4-5
Inserter (MJ-7001) .....	4-6
Large capacity feeder (MP-4003L/A).....	4-6
Network printer board (GA-1140) .....	4-7
Expansion memory (GC-1080).....	4-7
PS3 upgrade (GE-1020).....	4-7
PS3 & HDD upgrade (GE-1060).....	4-7
Scan accelerator (GE-1110).....	4-8
DSS controller (GL-1020/1020E).....	4-8

<b>5. Service Features .....</b>	<b>5-1</b>
A. Firmware Updating .....	5-1
Using PC via serial interface.....	5-2
Using Jig board.....	5-2
B. Estimated Installation Time .....	5-3
C. Consumables .....	5-4
D. Periodic Replacement Parts .....	5-5
E. Consumable Parts of Options .....	5-5
Large capacity feeder (MP-4003L/A).....	5-5
F. Customer Maintenance .....	5-6
G. Preventive Maintenance (PM) Items .....	5-7
Cleaning items .....	5-8
Lubrication items.....	5-10
Replacement items (a).....	5-11
Replacement items (b).....	5-11
H. Recommended Monthly Print/Copy Volume .....	5-12
<b>6. Service Support.....</b>	<b>6-1</b>
A. TABS-Electronic Imaging Division, Service Organization .....	6-1
B. Service Policy.....	6-2
C. Internet FYI Portal - Training.....	6-2
D. Internet FYI Portal - TECH-TO-GO .....	6-3
E. Technical Support Hotline .....	6-3
F. On-Site Support.....	6-5
<b>7. Cost/Copy Information .....</b>	<b>7-1</b>
A. Maximum Monthly Copy Volume.....	7-1
B. e-STUDIO550 Cost/Copy Data Sheet.....	7-2
C. e-STUDIO650 Cost/Copy Data Sheet.....	7-3
D. e-STUDIO810 Cost/Copy Data Sheet.....	7-4
<b>8. Technical Training-Digital Copier.....</b>	<b>8-1</b>
A. Training Program .....	8-1
B. Who Should Attend Training .....	8-1
C. Training Prerequisites .....	8-1
D. What The Training Covers (Course Content).....	8-2
E. Training Locations.....	8-3
F. Training Format.....	8-3
G. Training Equipment.....	8-4
H. Documentation.....	8-4
I. Unique Tools and Adjustment Jigs .....	8-5
J. Dealer-Administered Technical Education Program (DATE) .....	8-6
<b>9. Service Requirements .....</b>	<b>9-1</b>
A. Service Authorization .....	9-1
B. Service Recommendations .....	9-1
<b>10. Warranty.....</b>	<b>10-1</b>
A. Warranty Policy .....	10-1
B. Toshiba America Business Solutions, Inc. Limited Warranty .....	10-1

<b>11. Appendix — Optional Controller Features .....</b>	<b>11-1</b>
A. Each Controller in Market Map .....	11-1
B. Controller Functions .....	11-2
C. GA-1140 Specifications .....	11-5
System requirements .....	11-5
Connector cable .....	11-5
For Windows .....	11-5
For Macintosh .....	11-6
TopAccess .....	11-6
Network server .....	11-6
Applications .....	11-7
Command WorkStation .....	11-7
Fiery FreeForm .....	11-7
Fiery WebTools .....	11-7
DocBuilder/DocBuilder PRO .....	11-7
D. GL-1020 Specifications .....	11-8
System requirements .....	11-8
Connector cable .....	11-8
For Windows .....	11-8
For Macintosh .....	11-9
For UNIX .....	11-9
TopAccess .....	11-9
Network server .....	11-10
Applications .....	11-10
GL-DocMon .....	11-10
E. Service Support .....	11-11
Service Policy .....	11-11
Internet FYI Portal - Training .....	11-11
Internet FYI Portal - TECH-TO-GO .....	11-12
Technical Support Hotline .....	11-12
On-Site Support .....	11-14
F. Technical Training- Controllers .....	11-15
Training Program .....	11-15
Who Should Attend Training .....	11-15
Training Prerequisites .....	11-15
What The Training Covers (Course Content) .....	11-16
Training Locations .....	11-16
Training Format .....	11-17
Training Equipment .....	11-17
Documentation .....	11-17
Controller Service Kits .....	11-18
Dealer-Administered Technical Education Program (DATE) .....	11-18
G. Service Requirements .....	11-19
Service Authorization .....	11-19
Service Recommendations .....	11-19
H. Warranty .....	11-20
Warranty Policy .....	11-20
Toshiba America Business Solutions, Inc. Limited Warranty .....	11-20

# 1. Product Overview

The Toshiba e-STUDIO550/650/810 has been designed to serve the most demanding business environment, responding successfully to the specific needs of both general office and professional users by offering our “High Speed Solution” with powerful performance and high productivity. We believe we have succeeded in creating a MFP system, which incorporates the benefits of a durable compact design, strong paper handling features, various network solutions, high usability, and promotes the highest environmental standards.

These features make up the powerful foundation of Toshiba’s new line of multifunctional systems, and mark our vision for future models with more power, more possibilities, faster response and rock solid solutions.

## **High Speed, High Image Quality and Efficient Paper Handling**

Toshiba has shortened the warm-up time by one-third—to 160 seconds, and the recovery time is also faster due to the Toshiba’s newly developed Twin IH Fusing. The e-STUDIO550/650/810 is faster and more efficient in many ways and provide high-speed image processing at 55, 65, or 81 pages per minute, respectively, with enhanced printing resolution of 2400 x 600dpi. First copy time is a quick 3.2 seconds. Other technological landmarks, such as Serial Filter and Sharp Edge Processing have greatly increased the quality of copy/print outputs.

The new standard of Stackless Automatic Duplexing Unit (ADU) helps to assure productive duplex printing, while fast and accurate paper feeding occurs through the new standard of sheet-through type Reversing Automatic Document Feeder (RADF).

Maximum paper capacity is 7,600 sheets. The multiple paper sources allow users to take full advantage of the e-STUDIO550/650/810’s advanced paper handling capabilities. Optional 4,000 sheets Large Capacity Feeder (LCF) provides the flexibility to configure only if necessary. The system not only accepts heavy 110 lbs paper or 209g/m<sup>2</sup>. Index paper through all available paper sources, but it can also accept and print on Tab paper through a special built-in cassette. When used in conjunction with the Cover Sheet and Sheet Insertion Features, users can get the document production capability they need all in one system.

The e-STUDIO550/650/810 offers two types of optional Finishers, optional Hole Punch Units, and an optional Inserter. The competitive stapling along with electronic sorting allows unlimited set production. Saddle-stitch finishing combined with the magazine sort feature brings document production to a whole new level. Adding the Hole Punch and Inserter provides users with everything they need to create in-house finished documents.

### **Compact but Durable**

Toshiba has designed a completely new engine achieving a major size reduction of approximately 8.66" (220mm,) thereby successfully reducing the width of the system down to 27.48" (698mm.) As a result of this accomplishment, customers can enjoy more free space. But even more importantly, they can install a high-speed system in places they might have never thought of before. The e-STUDIO550/650/810 offers greater convenience and productivity despite its compact size.

Another goal of redesigning the MFP system has been to achieve higher durability and reliability. Toshiba has accomplished a Preventive Maintenance cycle for all three models that is now approximately 15 per cent longer than before, making it among the highest in the industry—the e-STUDIO550/650/810 offers a PM cycle of 400k, 460k, and 500k, respectively.

### **Various Network Solutions**

As today's workplace has become more integrated into various networks, demands for flexible and easy solutions have increased. The e-STUDIO550/650/810 is a fully upgradeable network connected multifunction product. The e-STUDIO550/650/810 is based on a modular architecture allowing users to upgrade the standalone digital copier to a fully connected network document processing device. Separate network solutions with a variety of printing and scanning options for each are available for the e-STUDIO550/650/810 as Toshiba realizes that different users have different needs.

The GA-1140 fulfills most basic needs and provides solid solutions within an economical range. The system comes with a wide array of supported high-speed print/copying features. The GL-1020 provides a wide range of network document solutions, including versatile scanning functions, Internet connectivity, document editing function and high performance print. The GA-1140 with optional HDD GE-1060 targets the print-for-pay-market, copy shops and other specialized users, and advocates the use of various EFI™ software applications.

### **Easy to Use and Easy to Access**

The overall control panel appearance has been designed to be readily visible and easy to use even for visually challenged people. Large sized concave buttons, items displayed in the LCD touch panel that are highlighted when being touched for easy recognition are attractive main features that ensures ease of use for every user.

The e-STUDIO550/650/810 introduces a new approach to control panel design, which provides the user with easy-to-understand touch panel display guides and easy step-by-step procedures, including setting confirmation. Furthermore, the Printer Driver Window allows users easy-to-understand access to frequently used functions.

**Environmental Friendly**

Toshiba has always valued the importance of using recycled materials whenever possible and incorporates features to reduce power consumption and noise levels for the benefit of the working environment. Our e-STUDIO550/650/810 reflects these commitments in the careful design and implemented technology, such as the employment of the Toshiba's innovative Twin IH Fusing system, which has shortened the warm-up time to enhance energy conservation. Furthermore, the xenon exposure lamp consumes less power, and almost all screws and sheet metal parts are now chromium free, even the electrical circuit boards have minimal usage of halogen and lead.

Toshiba is committed to always find efficient and environmental friendly solutions for current and future product releases.

## 2. Design Features

### A. Basic Features

#### **First Copy & Short Warm-up Time**

The e-STUDIO550, 650 and 810 are advanced high-speed solutions, each with a remarkable first copy speed of 3.2 seconds, and thanks to Toshiba's advanced Twin Induction Heating (IH) Fusing Technology, its warm-up time has also been shortened dramatically—only 160 seconds. This has not only improved energy consumption and reduced cost, but now makes the e-STUDIO550/650/810 faster and more efficient than previous models. Each unit is now in a ready-to-use state as soon as they are turned on.

#### **Auto Job Start & Job Reservation**

Users can now take advantage of the advanced Auto Job Start capability, which enables users to Pre-Scan original documents while the system is still warming up. After warming up, the job will be automatically initiated. This means that you can return to your desk with the originals before the system has started printing the pages from memory.

Users can also take advantage of the advanced Job Reservation capability. This enables users to use Pre-Scan during printing and copying as the concurrent process works independently of printing and scanning. It is possible to reserve up to five different jobs, each of which will start automatically as the previous job finishes. This improves overall productivity and convenience in conjunction with the benefits gained from the Auto Job Start capability.

In general, these rationalizations save time and allow the user to concentrate on their primary work.

#### **Memory Capacity**

The e-STUDIO550/650/810 comes equipped with a standard 32MB Page Memory Board and a 10GB Hard Disk Drive, which suits users who frequently work with large-volume and graphics-heavy documents requiring a large amount of storage space. The high memory capacity as standard enables the use of Electronic Sort for large size jobs, up to 1,000 images per job. This system makes it possible to sort without the need for mechanical sorters.

It is usually the RADF unit that becomes the bottleneck when processing documents. The RADF unit of the e-STUDIO550/650/810, however, can easily handle a 100 sheets stack (i.e. 200 pages in duplex mode). This process can be additionally repeated up to nine times in simplex mode, or up to four times in duplex mode. This capacity should be more than enough for most users needs.

### **Paper Capacity**

The e-STUDIO550/650/810 offers a high maximum online paper volume that meets the widest range of business needs. It features a standard paper capacity of up to 3,600 sheets, including the upper and lower drawers—each hold a maximum of 500 sheets, the standard Tandem LCF (Large Capacity Feeder)—a maximum of 2 x 1,250 sheets, and the Stack Feed Bypass, which can handle up to 100 sheets. Adding the optional 4,000 sheets LCF—a space saving front load type—provides an impressive maximum total capacity of 7,600 sheets of paper.

### **Thick Paper Handling**

Besides various plain paper stocks, the e-STUDIO550/650/810 can handle a variety of special paper, including thick paper between 17 lbs. bond paper up to 110 lbs. Index paper or 64-209g/m<sup>2</sup> from all paper sources. With the optional Inserter MJ-7001 installed, it is possible to insert up to 140 lbs. Index paper or 256g/m<sup>2</sup> thick paper—thus making it easy to produce professional-looking booklets and other presentation materials quickly and easily.

### **Tab Paper Handling**

Users can take advantage of the new advanced tab paper handling features, which enables the feeding of tab paper from the stack feed bypass or the lower drawer, and also insert them at the designated pages. Moreover, this feature provides the ability to print on tab paper, both in copy and print mode.

### **Optional Finishers & Hole Punch Units**

Two types of optional Finishers and Hole Punch Units are offered with the e-STUDIO550/650/810. The optional Finisher MJ-1017 offers four kinds of multi-position stapling up to 50 sheets. The optional Finisher MJ-1018 has the same function as the Finisher MJ-1017, but also provides the ability to saddle-stitch and magazine fold.

All two types of Finishers have two bins, each with a maximum tray capacity of 2,000 sheets—a total of 4,000 sheets. The Hole Punch Unit MJ-6003 can punch two, three or four holes in the document without decreasing the speed of the finishing. The Hole Punch Unit is only available when one of the Finishers is installed.

### **Department Code**

Users can easily implement several access restrictions through the Department Code function. Moreover, the Department Code setting assists an administrator in knowing how many copies each group or department has made. Up to 150 department codes can be entered. The administrators are authorized to print out the copy counter and to reset the counter.

## Power Saving Mode

Several energy saving options are available. The Energy Saving Mode keeps a low fuser temperature while the system is in standby status to save energy. When the system receives a print job, it switches automatically to Normal Mode. The user can also turn the system to a standby status any time by pressing the Energy Saving Key. In addition, an Automatic Energy Saving Mode will be activated when the system is left inactive for a certain period of time. A similar feature is the Auto Shut Off/Sleep Mode, which automatically shuts off power when the system has not been in use for a specific period of time. With the optional printer controller installed and when activated by a print job command, the system switches automatically to Normal Mode. Another energy saving option is the Weekly Timer, which allows users to set a time to automatically start up or shut down the system each day.

## Other Convenient Basic Features

The e-STUDIO550/650/810 comes with a variety of other convenient basic features that can minimize additional workloads, including:

**Text/Photo Mode:** The Text/Photo mode is the default setting and produces outstanding copy quality for most originals. However, if you want the best quality in text reproduction, you can also manually select the Text mode, and the Photo mode in photo or gray-scaled image reproduction.

**X-Y Zoom:** Different reproduction ratios can be set for the X (horizontal) and Y (vertical) directions.

**2-in-1, 4-in-1,**

**8-in-1(duplex):** A two- or four-page document can be reduced and copied onto one sheet of paper.

**Job Memory:** Saves users from having to set copying modes every time they make copies in a fixed format. Making full use of the Job Memory, the users can store a combination of frequently used copy settings in advance, including reproduction ratio, copy density and quantity and paper size. Up to four combinations can be stored.

**Mirror Image:** Copies are made with images completely reversed side by side. Make copies in a fixed format. Making full use of the Job Memory, the users can store a combination of frequently used copy settings in advance, including reproduction ratio, copy density and quantity and paper size. Up to four combinations can be stored.

## **B. Basic Features with Optional Controller**

The following will introduce some of the basic features, which apply for each optional controller.

### **Easy Understandable Printer Driver Window**

Basic output related setting (paper size, number of prints, orientation, media type) and frequently used functions (finishing, and duplex, etc) have been integrated in the default screen of the Printer Driver for easy access.

### **Private Print**

The Private Print function allows users to store sensitive or confidential documents, which have been sent from the user's PC for printing, in the memory of the e-STUDIO550/650/810 until the user releases it to print by entering a private document password from the touch panel display.

### **Watermark**

Users can type in their Watermark text and then select the font size and type, shading and even the direction they want the watermark to be imprinted across the page. There is room to create and save numerous watermarks in this way.

### **N-up Printing**

N-up Printing enables the printing of up to 16-up printouts on simplex printing and a maximum 32-up printing on duplex printing for thumbnail reference. These are useful for software applications such as PowerPoint, when users wish to view an entire set of documents on one sheet of paper instead of printing on individual sheets.

### **Proof Print**

The Proof Print function allows users to check the output of the print job on a sample copy before completing the multi-copy job. This acts as a safety measure, which prevents costly mistakes and ensures that the users get exactly what they expect.

### **TopAccess™ —Web-based System Administration Utility**

TopAccess™ is a system administration utility accessible via the user's Internet Browser. It allows users to check the status of the system such as Paper Cassette Empty, Printer Error, Jamming, Finisher Error, Call for Service, and so on. The print Job status notifications include printing order (also known as queuing or spooling) and confirmation of job completion, as well as Printing, Waiting, and Error messages. It is also possible to check other document specific information like user name, document name, paper size selected, volume and even the time when the job was sent to the printer. Moreover, it is also possible to check usage information on users in other departments and how much they are printing out.

### **GL-DocMon™ (Only GL-1020)**

Another important feature is the GLDocMon™ software, which is a job monitoring tool that provides event notification about current print job status, error conditions, or job completions. All information will appear as individual pop-up dialog messages.

## **C. New Technology Introduction**

Toshiba's MFP system, the e-STUDIO550/650/810 comes with numerous attractive features based on new technological advances. The following sections explain in detail these innovative key technologies that have been applied to Toshiba's new digital MFP systems.

### **Key Technologies:**

Toshiba's MFP system has several points in its favor, in particular

- Twin IH Fusing System
- Sharp Edge & Serial Filter Processing
- Toner Recycling System
- Stackless ADU
- New Sheet-Through Type RADF
- Inserter

### **Twin IH Fusing System**

The e-STUDIO550/650/810 is equipped with Toshiba's unique Twin IH Fusing system with vast implications for increased energy conversion efficiency. This makes it possible to keep a flat distribution of roller surface temperature. Thanks to this technological improvement, a warm-up time of approximately 160 seconds and a dramatically reduced recovery time are achieved. Since the recovery time has become faster, the Energy Save Mode has become even easier to use. This has resulted in more efficient energy saving and reduced cost, where the automatic power saving mode reduces power consumption, and when the copier is left inactive for a certain period of time, and where using the Energy Saver Key on the Control Panel minimizes power consumption.

### **Sharp Edge & Serial Filter Processing**

Toshiba is constantly searching for new methods to ensure the highest image quality possible and finding better ways to improve high-resolution technologies which reproduce naturally curved lines. This means an increased reproduction level, resulting in smoother, clearer and crisp reproduction of text and graphics with no decrease in printing speed. Serial Filter and Sharp Edge Processing are advanced reproduction technologies, which are based on unique algorithms that perform better than conventional algorithms. Serial Filter processing vastly improves reproduction of details, offering crystal clear rendition of small, lightly colored letters and handwritten signatures. Moreover, thanks to Sharp Edge Processing, the e-STUDIO550/650/810 eliminates blur and outputs highly defined images. Edges are supremely sharp for both copied text and graphics. And bold lettering looks simply fabulous.

### **Toner Recycling System**

The e-STUDIO550/650/810 employs a new, advanced toner recycling system, which takes into account environmental considerations. The toner recovered by the cleaner is transported to the toner recycling hopper. The recovered toner is mixed with fresh toner in the mixing unit, and then sent to the developer. In this final process, about 90% of waste toner particles are recycled, with no degradation of quality in comparison to 100% fresh toner. The new advanced toner recycling system is therefore a truly resource conserving system.

### **Stackless ADU**

The Stackless Automatic Duplexing Unit (ADU) that is now employed in the e-STUDIO550/650/810 can reverse paper without stacking it, and it is structurally less complex than previous ADUs. As a result of this mechanical rationalization and simplicity, there are fewer problems such as paper jams in the case of duplex copying. Even in the unlikely event that a paper jam does occur, trouble-shooting is now much easier and the user can have the machine back online in a few moments. In particular as only one sheet is ever in the duplex unit at any one time.

### **New Sheet-Through Type RADF**

In comparison with previous models, the e-STUDIO550/650/810 comes with a totally redesigned and improved standard Reversing Automatic Document Feeder (RADF).

The new RADF is designed as a sheet-through type model, which has the new internal sensing and paper transport mechanisms. It has not only improved two-sided scanning speed, but has also improved transport deviation and skew, thereby increasing the accuracy of every copy. A maximum of 100 sheets of paper (from LD to ST, A3 to A5) can be stacked on the RADF at a time and it can handle paper between 13-34lbs, 50-127g/m<sup>2</sup> in weight. Therefore, the new sheet-through type RADF provides significantly more accurate handling of large print jobs of two-sided originals, making it ideal for professional users like the POD market.

### **Post Fuser Inserter**

The e-STUDIO550/650/810 can be equipped with a newly developed optional Inserter. This Inserter provides an extra degree of functionality since it makes it possible to automatically—and accurately—insert separately made covers and color photos at the proper places in a printout. In this regard it is worth mentioning that the possibility of surface damage to color prints has been eliminated, because the inserted paper is not transported through the system's internal mechanism and therefore is not affected by the heat from the fuser unit.

The Inserter is certainly a blessing for booklet making and the production of promotional materials. 15 sheets of paper can be inserted per set, and the Inserter accepts up to 100 sheets of paper. The range of paper types that can be handled includes normal paper, color-coated paper, thick paper up to 140lbs or 256g/m<sup>2</sup> stock, and OHP sheets.

For even greater flexibility the Inserter incorporates its own fully independent control panel. This enables the unit to be used "off-Line" to staple, hole punch and even saddle stitch documents previously produced on other systems in the office environment.

# 3. Configuration

## A. System Configuration

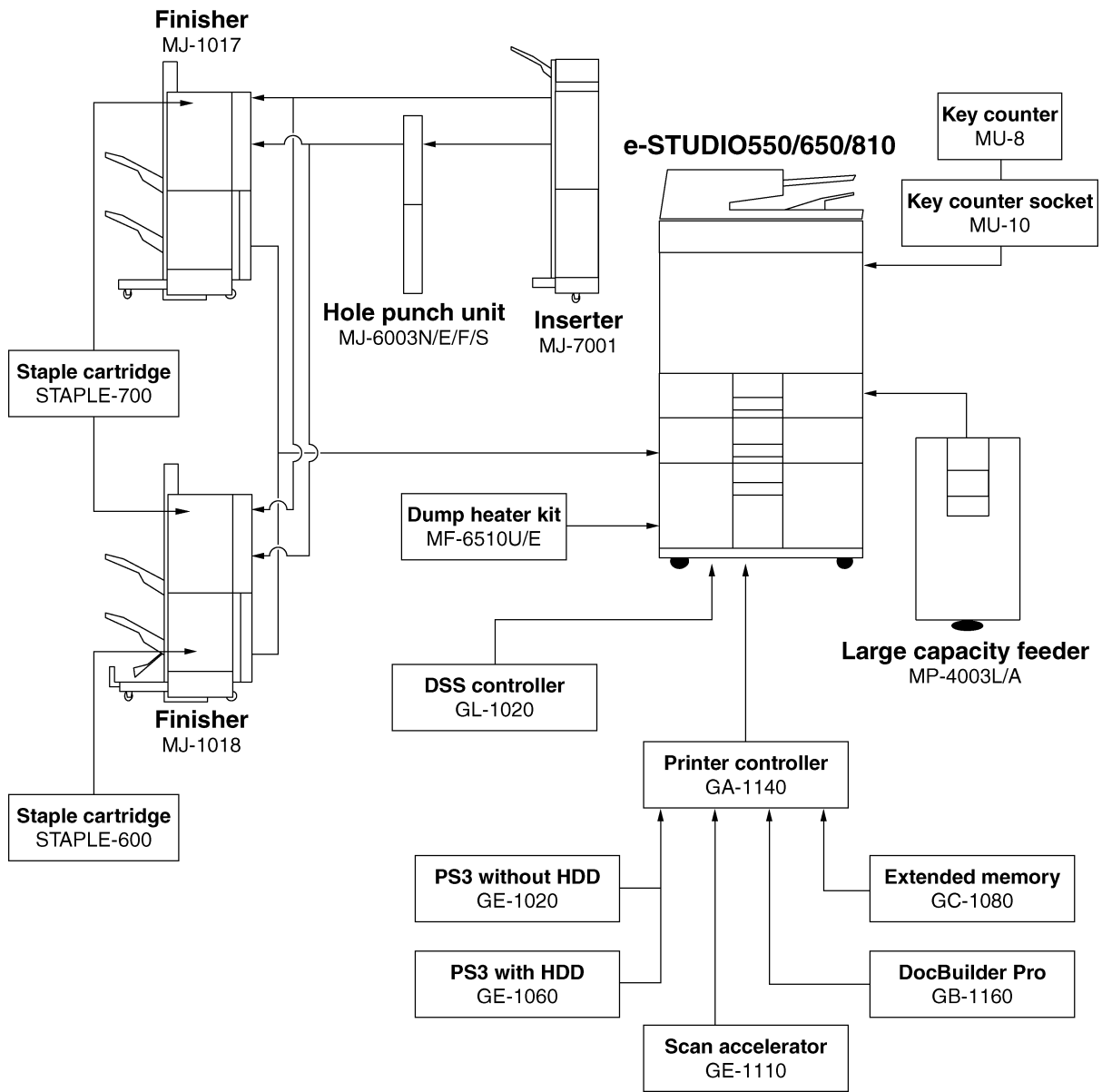

## B. Copy Paper Configuration

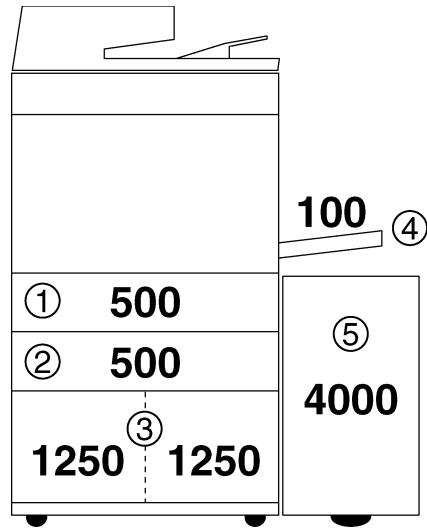

No.	Copy paper feeder		Paper capacity (sheets)
1	e-STUDIO550/650/810	1st cassette (Upper)	500
2		2nd cassette (Lower)	500
3		Tandem LCF	2500 (1250 x 2)
4		Bypass guide	100
5	MP-4003L/A (Option)	Optional LCF	4000

- e-STUDIO550/650/810 paper capacity (1 + 2 + 3 + 4): **3600 sheets**
- Maximum paper capacity (1 + 2 + 3 + 4 + 5): **7600 sheets**

### C. Original Configuration

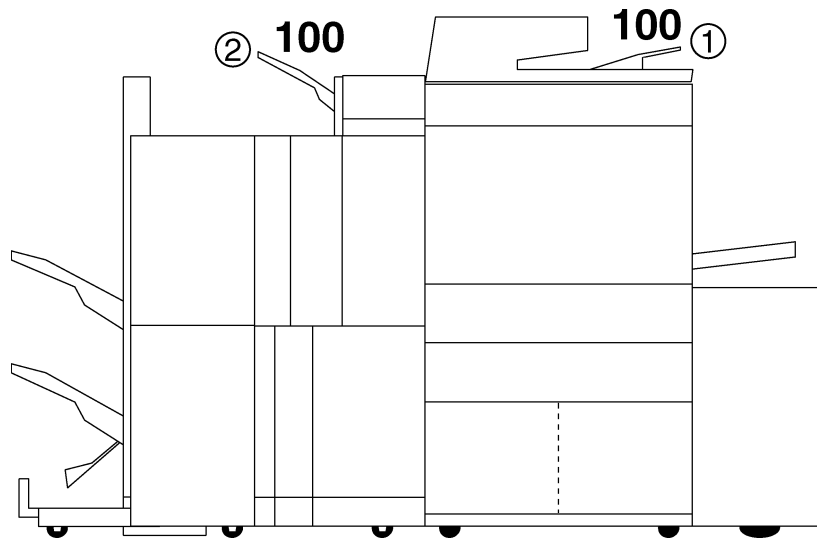

No.	Original feeder		Paper capacity (sheets)
1	e-STUDIO550/650/810	RADF	100
2	MJ-7001 (Option)	Inserter	100*

\* The originals placed in the inserter cannot be copied. They can be used to insert into the pages you desire as cover sheets or blank paper during printing. Also, when you use the finisher functions (staple or hole puncher) without making copies, place the originals in the inserter.

## D. e-STUDIO550/650/810

Item		Code
e-STUDIO550	NAD	660-81338
	TWD	660-81339
	SAD	660-81340
	ASD	660-81341
	AUD	660-81342
	MJD	660-81343
e-STUDIO650	NAD	660-81344
	TWD	660-81345
	SAD	660-81346
	ASD	660-81347
	AUD	660-81348
	MJD	660-81349
e-STUDIO810	NAD	660-81350
	TWD	660-81351
	SAD	660-81352
	ASD	660-81353
	AUD	660-81354
	MJD	660-81355

\*Machine Version

NAD: North America

TWD: Taiwan

SAD: Saudi Arabia

ASD: Asia

AUD: Australia

MJD: Europe

## E. Accessories

Item	Quantity	Remarks
Unpacking/setup instructions	1pc.	
Operator's manual	1pc.	
Operator's manual pocket	1pc.	
Setup report	1pc.	For NAD and MJD
Customer satisfaction card	1pc.	For MJD
Warranty sheet	1pc.	For NAD
PM check list	1pc.	For MJD
Drum	1pc.	
Drum cover	1pc.	
Toner bag	1pc.	
Spacer for ADF original tray	1pc.	
Trailing edge guide for tab paper	1pc.	
Power cable	1pc.	For ASD, AUD and MJD

## F. Options

Item		Code	Remarks
Finisher	MJ-1017	660-89840	
	MJ-1018	660-89841	
Hole punch unit	MJ-6003N	660-89842	
	MJ-6003E	660-89843	
	MJ-6003F	660-89844	
	MJ-6003S	660-89845	
Insertor	MJ-7001	660-89846	
Staple cartridge	STAPLE-600	660-84999	For MJ-1018
	STAPLE-700	660-84989	For MJ-1017 and MJ-1018
Finisher guide rail	KN-1017	660-89903	
Large capacity feeder	MP-4003L	660-89847	LT
	MP-4003A	660-89848	A4
Damp heater kit	MF-6510U	660-89885	For NAD
	MF-6510E	660-89886	For MJD
Key counter	MU-8	660-02050	
Key counter socket	MU-10	660-02051	
Network printer board	GA-1140	660-89871	
Expansion memory	GC-1080	660-89724	For GA-1140
PS3 upgrade	GE-1020	660-89623	For GA-1140 *Common with GA-1040
PS3 & HDD upgrade	GE-1060	660-89872	For GA-1140
Scan accelerator	GE-1110	660-89897	For GA-1140
DocBuilder Pro	GB-1160	660-89879	For GA-1140 *Common with GA-1120/1130
DSS controller	GL-1020	660-89870	For 100V range machine
	GL-1020E	660-89894	For 200V range machine

## G. Accessories for Options

### Finisher (MJ-1017/1018)

Item	Quantity	Remarks
Finisher itself	1pc.	
Unpacking/setup instructions	1pc.	
Latch receiving bracket	1pc.	
Blind cover	1pc.	
Connecting rail	1pc.	
Rail attachment plate	1pc.	
Finisher attachment bracket	1pc.	
Positioning bracket	1pc.	
Locking support	1pc.	
IPC board	1pc.	
Fixing screws	14pcs.	
Label	1pc.	For MJ-1018

### Hole punch unit (MJ-6003N/E/F/S)

Item	Quantity	Remarks
Hole punch unit itself	1pc.	
Unpacking/setup instructions	1pc.	
Finisher rear cover	1pc.	
Blind cover	1pc.	
Fixing screws	7pcs.	
Label	1pc.	

### Inserter (MJ-7001)

Item	Quantity	Remarks
Inserter itself	1pc.	
Unpacking/setup instructions	1pc.	
Extension rail	1pc.	
Base unit	1pc.	
Harness band	1pc.	
Connector cover	1pc.	
Fixing screws	12pcs.	
Paper role	1pc.	

**Finisher guide rail (KN-1017)**

Item	Quantity	Remarks
Finisher guide rail itself	2pc.	
Unpacking/setup instructions	1pc.	
Rail fixing bracket	2pcs.	
Fixing screws	4pcs.	

**Large capacity feeder (MP-4003L/A)**

Item	Quantity	Remarks
Large capacity feeder itself	1pc.	
Unpacking/setup instructions	1pc.	
Latch bracket	2pcs.	
Attachment bracket	1pc.	
Slide rail unit	1pc.	
Attachment rail	2pcs.	
Connector cover	2pcs.	
Fixing screws	24pcs.	

**Damp heater kit (MF-6510U/E)**

Item	Quantity	Remarks
Damp heater (DRUM)	1pc.	
Damp heater (SCANNER-R)	1pc.	
Damp heater (SCANNER-L)	1pc.	
Unpacking/setup instructions	1pc.	
Fixing screws	5pc.	

**Network printer board (GA-1140)**

Item	Quantity	Remarks
Network printer board itself	1pc.	
Unpacking/setup instructions	1pc.	
Fixing screws	4pcs.	
User software CD-ROM	1pc.	
Documentation CD-ROM	1pc.	
Quick start guide	1pc.	

**Expansion memory (GC-1080)**

Item	Quantity	Remarks
DIMM	1pc.	
Unpacking/setup instructions	1pc.	

**PS3 upgrade (GE-1020)**

Item	Quantity	Remarks
IC chip	1pc.	
Unpacking/setup instructions	1pc.	

**PS3 & HDD upgrade (GE-1060)**

Item	Quantity	Remarks
IC chip	1pc.	
HDD	1pc.	
Unpacking/setup instructions	1pc.	
Brackets	2pc.	
Wire harness	1pc.	
Fixing screws	8pc.	

**Scan accelerator (GE-1110)**

Item	Quantity	Remarks
Scan accelerator board itself	1pc.	
Unpacking/setup instructions	1pc.	

**DocBuilder Pro (GB-1060)**

Item	Quantity	Remarks
DocBilder Pro CD-ROM	1pc.	
Unpacking/setup instructions	1pc.	
Dongle	1pc.	
Install document	1pc.	

**DSS controller (GL-1020/1020E)**

Item	Quantity	Remarks
DSS controller itself	1pc.	
Unpacking/setup instructions	1pc.	
Fixing screws	9pcs.	
Power supply cable	1pc.	
Recovery CD-ROM	1pc.	
Admin's client CD-ROM	1pc.	
Scanner client CD-ROM	1pc.	
Client CD-ROM	1pc.	For GL-1020
	3pcs.	For GL-1020E
Quick start guide	1pc.	

## H. Replacement Units

Item		Code	Remarks
Cleaner/Drum unit	CLN/DRUM-6510	6LA06872000	
Developer unit	DEVE-UNIT-6510	6LA06870000	
Main charger unit	MAIN-CH-6510	6LA06873000	
Transfer belt unit	TR-BLT-6510	6LA06874000	
Fuser unit	FUSER-8110-115	6LA06877000	For 100V range machine
	FUSER-8110-200	6LA06878000	For 200V range machine

## I. Supplies

Item		Code	Remarks
Drum	OD-6510	6LA23006000	
Developer	D-6510	6LA23011000	
Toner	PS-ZT6510	660-61626	For NAD
	PS-ZT6510E	660-61627	For MJD *Made in TABS
		660-62060	For MJD *Made in TEIS
	PS-ZT6510D	660-61628	For TWD, SAD, ASD and AUD *Made in TABS
		660-62061	For TWD, SAD, ASD and AUD *Made in TEIS
		660-89882	For TWD, SAD, ASD and AUD *Made in Japan
Toner bag	PS-TB6510	660-89851	For NAD, TWD, SAD, ASD, AUD
	PS-TB6510E	660-89852	For MJD

### —Toshiba Original Supplies and Parts —

Stress to your customers that Toshiba's original supplies and parts assure the highest copy quality with consistent results, whatever the operating environment or the job size.

Use of Toshiba original supplies contributes to fewer service calls and greater copier durability.

## 4. Specifications

### A. e-STUDIO550/650/810

Model name	DP-5510/6510/8110
Type	Console type
Original glass	Fixed (original referenced to top left, referenced to center when using RADF)
Copying system	Indirect electrophotographic method
Developing system	2-component magnetic brush developing
Fixing method	Heat roller (Induction heating)
Photoconductor type	OPC Drum
Original scanning system	Linear CCD sensor
Light source	Xenon lamp
Resolution	600dpi x 2400dpi with smoothing
Page memory	RAM: 32MB, HDD: 10GB
PM cycle	e-STUDIO550: 400k sheets e-STUDIO650: 460k sheets e-STUDIO810: 500k sheets
Acceptable originals	Sheets, books and three-dimensional objects
Max. original size	LD or A3
Reverse auto document feeder (RADF)	Standard, Sheet through type
Acceptable original paper size	LD, LG, LT, LT-R, ST-R, COMP A3, A4, A4-R, A5-R, B4, B5, B5-R, FOLIO
Acceptable original paper weight	Side original: 13-34lb., 50-127 g/m <sup>2</sup> 2-Side original: 13-28lb., 50-104 g/m <sup>2</sup>
Stack capacity	100 sheets (20lb., 80g/ m <sup>2</sup> Bond)
Original feeding speed	65 originals/min.
First copy time	3.2 seconds or less (LT or A4, upper cassette, 100%, original placed manually)
Warm-up time	Approx. 160 seconds (+20% or less) (e-STUDIO550/650/810, Temperature: 20°C)
Multiple copying	Up to 9999 copies (digital key enter)
Reproduction ratio	Actual size: 100±0.5% Zoom: 25-400% (in 1% increments) For the RADF: 25-200% (in 1% increments)
Density control	Automatic density mode and manual density mode selectable 11 steps

Paper supply	Cassette x2, Tandem LCF, Sheet bypass
Cassette	Automatic feeding
Acceptable copy paper size	LT, LT-R, LG, LD, COMP, ST-R, 13"LG, 8.5"SQ, A4, A3, B5, B4, FOLIO, A4-R, A5-R, B5-R, 8K, 16K, 16K-R
Acceptable copy paper weight	17lbs bond - 110 lbs index paper, 64-209 g/m <sup>2</sup>
Copy paper capacity	500 sheets (20lb., 80g/ m <sup>2</sup> Bond)
Special paper	Tab paper *2nd cassette only
Tandem LCF	Automatic feeding
Acceptable copy paper size	LT or A4 only
Acceptable copy paper weight	17lbs bond - 110 lbs index paper, 64-209 g/m <sup>2</sup>
Copy paper capacity	2500 sheets (20lb., 80g/m <sup>2</sup> Bond)
Sheet bypass	Bypass feeding
Acceptable copy paper size	LD to ST-R or A3 to A5-R (Non standard or user-specified sizes can be set)
Copy paper capacity	100 sheets (20lb., 80g/m <sup>2</sup> Bond)
Special paper	Tracing paper labels, OHP film (thickness: 80µm or thicker), Tab paper *Special type of paper should be recommended by TOSHIBA
Toner supplying	Automatic toner density detection/supply Toner cartridge replacing method (There is a recycle toner supplying system.)
Automatic duplexing unit	Standard, Stackless/switchback type
Total counter	Mechanical counter
Dimensions (W) x (D) x (H)	Copier only: 27.48" x 30.59" x 47.76", 698mm x 777mm x 1213mm Full options: 29.49" x 30.59" x 47.76", 2019mm x 777mm x 1213mm
Weight	Copier only: Approx. 441lb., 200kg Full options: Approx. 721lb., 327kg
Power requirements	AC 115V, 50/60Hz, 20A AC 220-240V, 50/60Hz, 9A
Power consumption	2.0kw or less (115V series and 200V series)
Space occupied (W) x (D)	55.16" x 30.59", 1401mm x 777mm
Storage capacity	Max. 1000 images (1 job) (TOSHIBA's own chart).

## Continuous copying speed

(sheets/min.)

Paper size	Paper feeder	e-STUDIO550		e-STUDIO650		e-STUDIO810	
		Face up	Face Down	Face up	Face Down	Face up	Face Down
LT, ST-R, 8.5"SQ, A4, A5-R, B5	Cassette/ Tandem LCF	55	55	65	65	81	81
	Bypass	48	48	48	48	50	50
LT-R, A4-R, B5-R	Cassette/ Tandem LCF	44	42	50	48	61	56
	Bypass	42	42	42	42	44	44
LG, COMP, 13"LG, B4, FOLIO	Cassette/ Tandem LCF	39	35	43	40	52	45
	Bypass	37	35	37	37	39	39
LD, A3	Cassette/ Tandem LCF	34	30	37	34	43	37
	Bypass *1	33	30	33	33	34	34

- The values above are measured when originals are set on the original glass, and 1-sided, 100%, non-sort multi copies and normal papers are made.
- "Face up" and "Face down" in the table mean the paper exit faces.
- The bypass copying speed is as listed above when specifying the paper size, however when the paper size is not specified, the copy speed of all size is on "\*1".

## B. Options

### Finishers (MJ-1017/1018)

Model name	MJ-1017	MJ-1018
Type	Floor type	
Stacking method	Trays 1 and 2: by lifting tray	
Stacking orientation	Face-down	
Acceptable paper size	LD, LG, LT, LT-R, ST-R, COMP, A3, A4, A4-R, A5, A5-R, B4, B5, B5-R, FOLIO	
Acceptable paper weight	16lb. Bond - 110lb. Index, 60 to 209g/m <sup>2</sup>	
Mode	Non-sort, sort, Staple sort, Group	
Stacking capacity		
Non-sort, sort, group		
LT, ST-R, A4, B5, A5-R	9.84", 250mm (2000 sheets)	
LT-R, LG, LD, COMP, A4-R, B4, A3, B5-R, FOLIO	5.51", 140mm (1000 sheets)	
Staple sort		
LT, ST-R, A4, B5, A5-R	4.33", 110mm/50sets (750 sheets)	
LT-R, LG, LD, COMP, A4-R, B4, A3, B5-R, FOLIO	2.91", 74mm/50sets (500 sheets)	
Stapling position	Front diagonal, Rear, Rear diagonal, double	
Stapling capacity		
LT, ST-R, A4, B5, A5-R	20lb. Bond: 50 sheets 24lb. Bond: 30 sheets 28lb. Bond: 30 sheets	
LT-R, LG, LD, COMP, A4-R, B4, A3, B5-R, FOLIO	20lb. Bond: 30 sheets 24lb. Bond: 15 sheets 28lb. Bond: 15 sheets	
Staple cartridge	STAPLE-700 (5000 staples)	
Saddle stitcher	No	Yes
Stitching capacity		
LD, LT-R, A3, A4-R, B4	-	20lb.: 15 sheets 24lb.: 10 sheets 28lb.: 10 sheets
Saddle stitch staple cartridge	-	STAPLE-600 (2000 staples)
Hole punch unit	Optional (MJ-6003N/E/F/S)	
Inserter	Optional (MJ-7001)	
Dimensions (W) x (D) x (H)	24.2"(*29.1") x 24.8" x 40.3", 616(*740)mm x 630mm x 1023mm *The values inside in parentheses are measured when the subtray is pulled out.	
Weight	Approx. 92.59lb, 42kg	Approx. 136.7lb, 62kg
Power source	Supplied from the copier (24VDC, 5VDC)	
Power consumption	170W max.	

**Staple cartridge (STAPLE-600/700)**

Model name	STAPLE-600	STAPLE-700
Type	Saddle stitch staple cartridge (For MJ-1018)	50-sheets staple cartridge (For MJ-1017/1018)
Quantity	2000 staples x 3 cartridge /1 box	5000 staples x 3 cartridge /1 box

**Hole punch unit (MJ-6003N/E/F/S)**

Model name	MJ-6003N	MJ-6003E	MJ-6003F	MJ-6003S
Punch hole	2 or 3 holes	2 holes	4 holes	4 holes
Acceptable paper size	2 holes: LG, LT-R 3 holes: LD, LT	A3, A4, A4-R, B4, B5, B5-R	A3, A4	A3, A4
Acceptable paper weight	16 to 140lbs, 60 to 256 g/m <sup>2</sup> *Transparencies, reproducible, label paper, postcards and hole-punched paper cannot be handled.			
Punched hole diameter	0.31", 8.0mm (2 and 3 holes)	0.26", 6.5mm	0.26", 6.5mm	0.26", 6.5mm
Punched scrap capacity	3000 sheets or more	5000 sheets or more	5000 sheets or more	5000 sheets or more
Dimensions (W) x (D) x (H)	2.95" x 23.1" x 14.7" 75mm x 586mm x 373mm			
Weight	Approx. 10.8lb., 4.9kg			
Power source	Supplied from the finisher (24VDC, 5VDC)			
Power consumption	120W max.			

**Insertter (MJ-7001)**

Model name	MJ-7001
Paper setting orientation	Face-up
Paper alignment	Center
Acceptable paper size	LD, LG, LT, LT-R (12" wide paper) A3, A4, A4-R, B4, B5 (304.8mm wide paper)
Acceptable paper weight	16 to 140lbs, 60 to 256 g/m <sup>2</sup>
Special papers	OHP film, color paper (coated paper), hole-punched paper
Laded number of papers	100 at maximum for papers less than 20lbs or 80g/m <sup>2</sup> , number of papers up to 12mm of laden height for papers more than 20lbs or 80g/m <sup>2</sup> *Less than 60% of the above quantities for special papers
Dimensions (W) x (D) x (H)	21.0" x 24.1" x 42.2", 533mm x 612mm x 1072mm
Weight	Approx. 44.1 lb, 20kg
Power source	Supplied from the copier (24VDC, 5VDC)
Power consumption	171W max.

**Large capacity feeder (MP-4003L/A)**

Model name	MP-4003L	MP-4003A
Type	Front loading type	
Acceptable copy paper size	LT (16 to 110lbs)	A4 (64 to 209g/m <sup>2</sup> )
Copy paper capacity	4000 sheets (Stack height: within 428mm)	
Dimensions (W) x (D) x (H)	12.8" x 23.6" x 24.3", 326mm x 599mm x 617mm *Size of the large-capacity feeder with the copier.	
Weight	Approx. 88.2 lb, 40kg	
Power source	Supplied from the copier (24VDC, 5VDC)	
Power consumption	1.5kW max. (With the copier)	

**Network printer board (GA-1140)**

Model name	GA-1140
CPU	Intel Pentium III 500MHz
Memory	Standard: SDRAM 128MB Max. : 256MB (When GC-1080 is installed.)
Print speed	With e-STUDIO550: 55 pages/minute With e-STUDIO650: 65 pages/minute With e-STUDIO810: 81 pages/minute
Paper size	LD, LG, LT, COMP, ST, 13"LG, 8.5"SQ, A3, A4, A5, B4, B5, FOLIO
Resolution	600dpi x 2400dpi
Interface: Parallel	Conforming to IEEE-P1284 (Standard, Nibble, ECP)
Interface: NIC	Data transfer speed: 10/100Mbps Connector: 10base-T/100base-TX (RJ-45 connector)
Emulation	PCL6
PCL fonts	81 roman fonts
Applicable computer	IBM PC/AT computer and compatible. Macintosh computer (when PS3 upgrade or PS3 & HDD upgrade is installed.)

**Expansion memory (GC-1080)**

Model name	GC-1080
Type	128MB SDRAM, 168-pin DIMM

**PS3 upgrade (GE-1020)**

Model name	GE-1020
Emulation	PostScript 3
PS fonts	136 roman fonts

**PS3 & HDD upgrade (GE-1060)**

Model name	GE-1060
Emulation	PostScript 3
HDD Space	6GB
PS fonts	251 roman fonts

**Scan accelerator (GE-1110)**

Model name	GE-1110
Type	Board with ASIC for high speed scanning

**DSS controller (GL-1020)**

Model name	GL-1020
CPU	Intel Celeron 566MHz
Memory	SDRAM 256MB
HDD space	20GB
Print speed	With e-STUDIO550: 55 pages/minute With e-STUDIO650: 65 pages/minute With e-STUDIO810: 81 pages/minute
Paper size	LT, LT-R, LG, LD, COMP, ST-R, 13"LG, 8.5"SQ, A4, A3, B5, B4, FOLIO, A4-R, A5-R, B5-R, 8K, 16K, 16K-R
Interface: NIC	Data transfer speed: 10/100Mbps Connector: 10base-T/100base-TX (RJ-45 connector)
Emulation	PCL6, PostScript 3
PCL fonts	80 roman fonts
PS fonts	136 roman fonts
Dimensions (W) x (D) x (H)	9.76" x 5.04" x 13.3", 248mm x 128mm x 338mm
Weight	Approx. 8.8 lb, 4kg

## 5. Service Features

### A. Firmware Updating

In the e-STUDIO550/650/810, the functions of the copier are mainly controlled from five types of PC boards: System control PC board, Logic control PC board, Scanner control PC board, Printer control PC board and ADF board. A Flash ROM or Flash ROMs with firmware for controlling the functions is installed in each PC board.

Also, in the optional Inserter (MJ-7001), the firmware that control the operations of the Inserter is installed.

The firmware is mainly divided into System Firmware and Engine Firmware. (See below.)

When updating each firmware of the e-STUDIO550/650/810, use either of the following two methods.

- Connect the PC to the copier and then start to download the firmware.
- Perform downloading after the ROM with the written-in firmware has been installed in the jig board.

Firmware	PC board	Jig board to be used
System Firmware		
System firmware	System control PC board (SYS board)	K-PWA-DLS-320
UI data fixed section		
UI data common section		
1st language data		
2nd language data		
3rd language data		
4th language data		
5th language data		
6th language data		
Engine Firmware		
Printer ROM	Logic PC board (LGC board)	K-PWA-DLM-320
PFC ROM*		
Laser ROM	Printer control PC board (PLG board)	
Scanner ROM	Scanner control PC board (SLG board)	
RADF ROM*	ADF control board (ADF board)	
Inserter ROM* (Optional inserter's firmware)	Inserter control board	

\* Use the jig board to update the PFC ROM, RADF ROM and Inserter ROM. Updating by means of downloading from the PC is not possible.

### **Using PC via serial interface**

For updating, connect the PC to the serial interface of the e-STUDIO550/650/810 using a serial cable and send the firmware file stored in the PC (extension: .tz) via the PPP (Point-to-Point Protocol) and the FTP (File Transfer Protocol) to the copier.

The following environment is required for updating.

PC:	IBM PC/AT or compatible machine (Requires a RS-232C serial interface)
OS:	Microsoft Windows 95 Operating System Microsoft Windows 98 Operating System
Software:	Virtual modem FTP server/tools (ex. War FTP Daemon)
Cable:	RS-232C DTE-DTE cross cable (D-Sub 9 pin)

### **Using Jig board**

For updating, after the ROM with the latest written-in firmware has been installed in the jig board for updating, connect the jig board to the connector prepared on each PC board of the copier. When the power is turned on, the data in the Flash ROM(s) will be automatically rewritten.

This method can be used when the copier cannot be started because the firmware in the copier was damaged by a power failure, or when downloading from the PC failed.

When updating, the jig board to be used will be different depending on the type of firmware.

For the details of the combinations of the firmware and jig board, refer to "Jig board to be used" listed in the table.

## B. Estimated Installation Time

Item		Time (Approx.)
e-STUDIO550/650/810		46' 00"
Finisher	MJ-1017	17' 30"
	MJ-1018	
Hole punch unit	MJ-6003N	10' 30"
	MJ-6003E	
	MJ-6003F	
	MJ-6003S	
Inserter	MJ-7001	16' 00"
Staple cartridge	STAPLE-600	1' 00" (0' 30" x 2)
	STAPLE-700	0' 30"
Finisher guide rail	KN-1017	3' 00"
Large capacity feeder	MP-4003L	23' 30"
	MP-4003A	
Damp heater kit	MF-6510U	30' 00"
	MF-6510E	
Key counter, Key counter socket	MU-8, MU-10	3' 00"
Network printer board	GA-1140	12' 30"
Expansion memory	GC-1080 *1	
Scan accelerator	GE-1110 *1	
PS3 upgrade	GE-1020 *1	
PS3 & HDD upgrade	GE-1060	15' 00" *2
DocBuilder Pro	GB-1160	1' 30" *3
DSS controller	GL-1020	13' 30"
	GL-1020E	

\*1: The installation time of GA-1140 includes that of the GA-1140 options (GC-1080, GE-1110 and GE-1020).

\*2: The installation time of the GE-1060 means that of the GA-1140 and GE-1060.

\*3: The installation time of the GB-1160 includes that of the applications.

## C. Consumables

Item		Replacement (sheets)			Remarks
		e-STUDIO550	e-STUDIO650	e-STUDIO810	
Drum	OD-6510	400k	460k	500k	
Developer	D-6510	400k	460k	500k	
Toner	PS-ZT6510	60.1k	60.1k	60.1k	For NAD *No.71 chart
	PS-ZT6510E	60.1k	60.1k	60.1k	For MJD *No.71 chart
	PS-ZT6510D	60.1k	60.1k	60.1k	For TWD, SAD, ASD, AUD *No.71 chart
Toner bag	PS-TB6510	800k	920k	1000k	For NAD, TWD, SAD, ASD, AUD
	PS-TB6510E	800k	920k	1000k	For MJD

## D. Periodic Replacement Parts

Item		Replacement (sheets)			Remarks
		e-STUDIO550	e-STUDIO650	e-STUDIO810	
Drum blade	BL-6570D	400k	460k	500k	
Drum cleaning roller	B-6570	400k	460k	500k	
Heat roller	HR-8110-U	400k	460k	500k	
	HR-6570-L	400k	460k	500k	
H/R WEB	CW-6510	400k	460k	500k	
H/R WEB roller	PR-6510W	400k	460k	500k	
P/R cleaning metal roller	B-8070L	400k	460k	500k	
Transfer belt	BT-6510TR	400k	460k	500k	
Brush roller	B-6510TR	400k	460k	500k	
Transfer belt cleaning blade	BL-6510TR	400k	460k	500k	
PM kit	MO-KIT-8110	400k	460k	500k	
	FU-KIT-8110	400k	460k	500k	
	MA-KIT-8110	400k	460k	500k	
	PM-KIT-8110C	400k	460k	500k	
	PM-KIT-8110	400k	460k	500k	
	DF-KIT-8110	500k			
	ROL-KIT-81CST	200k			

## E. Consumable Parts of Options

### Large capacity feeder (MP-4003L/A)

Item		Replacement (sheets)	Remarks
PM kit	ROL-KIT-4003	200k	

## F. Customer Maintenance

Item	Timing	Remarks
Clean original glass	Weekly maintenance	
Clean original cover	Weekly maintenance	
Clean scanning area	Weekly maintenance	
Clean guide area	Weekly maintenance	
Replace toner cartridge	When "Add toner" message appeared	
Add staple cartridge	When "Set staple cartridge" message appeared	Only when the finisher (MJ-1017 or MJ-1018) is installed.

## G. Preventive Maintenance (PM) Items

In order to use the e-STUDIO550/650/810 and maintain it in good condition, preventive maintenance, such as cleaning, parts replacement, etc., must be performed every time a fixed number of the copies and printouts has been made in the copier.

The cycle of preventive maintenance performed according to a fixed period (PM cycle) differs depending on the model. The PM cycle of each model and the contents of the maintenance to be performed are as shown below.

### e-STUDIO550 (PM cycle: 400k sheets)

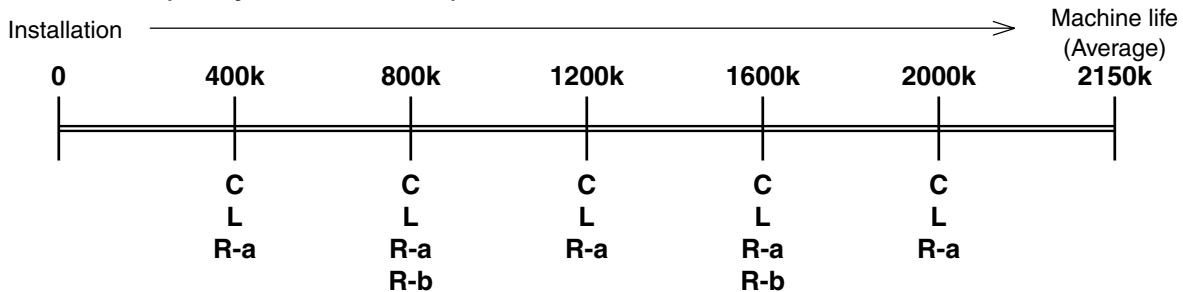

### e-STUDIO650 (PM cycle: 460k sheets)

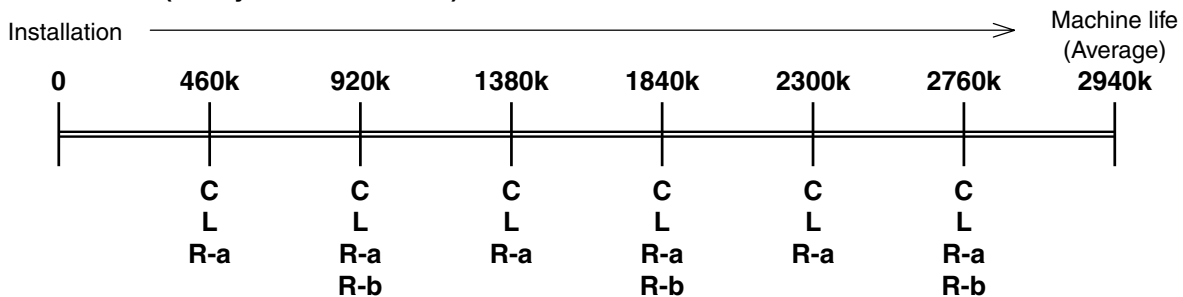

### e-STUDIO810 (PM cycle: 500k sheets)

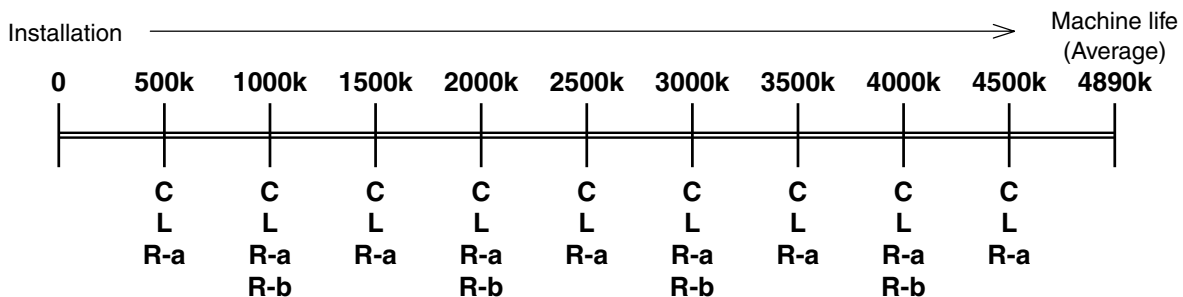

The meanings of the symbols in the above are as follows:

- C:** Cleaning --- Refer to "Cleaning items" table.
- L:** Lubrication --- Refer to "Lubrication items" table.
- R-a:** Replacement parts (a) --- Refer to "Replacement items (a)" table.
- R-b:** Replacement parts (b) --- Refer to "Replacement items (b)" table.

## Cleaning items

The items that should be cleaned at the timing of "C" (every PM cycle) are as shown below.

Section	Item	Remarks
Scanner	Original glass	
	ADF original glass	
	Mirror-1	
	Mirror-2	
	Mirror-3	
	Reflector	
	Lens	
	Exposure lamp	*1 Cleaning is unnecessary. Only check for deformation and damage.
	Automatic original detection sensor	
	Slide sheet (front and rear)	*1
Laser unit	Slit glass	
Feed unit	Transport roller	
	Paper guide (all)	
	Registration roller	*1
	Paper dust removal brush	*1
Bypass feed unit	Bypass tray	
Process related section	Discharge lamp	
	Drum shaft	
Main charger	Charger case	
	Contact point of terminal	
Drum/Cleaner	Recovery blade	*1
	Cleaner lower guide	
	Toner adhesion amount sensor	
	Drum shaft bearing	
Developer unit	Whole developer unit	
	Front shield	*1
	Guide roller	*1
Toner recycle	Whole toner recycle unit	
Transfer belt	Transfer belt power supply roller	*1
	Transfer belt drive roller	*1
	Transfer belt follower roller	*1
	Flicker periphery	
	Transfer belt power supply roller bearing and plastic bushing	

Fuser unit	Thermistor (4pcs.)	*1
	Fuser unit entrance/exit guide	
	Fuser roller drive gear/ cleaning WEB drive gear	*1 Cleaning is unnecessary. Only check for deformation and damage.
	Fuser roller bearing/ one-way bearing	*1 Cleaning is unnecessary. Only check for deformation and damage.
	Fuser unit exit roller	
Exit/Reverse section	Exit/Reversal guide	
	Exit roller	*1
	Reverse section transport roller (upper/lower)	*1
	Reverse section follower roller (upper/lower)	
	Horizontal transport section transport roller (4)	
	Horizontal transport section follower roller (8)	
	Reverse section mylar (2pcs.)	
	Paper guide	
RADF	Original length sensor	
	Registration roller	
	First roller	
	2nd roller	
	Read sensor	
	Read guide	
	Read roller	
	3rd roller	
	4th roller	
	Reverse sensor	
	Exit roller	
	Reverse roller	
	Platen sheet	

\*1: If a part is deformed or damaged, the part must be replaced immediately.

### Lubrication items

The items to which lubrication should be applied at the timing of "L" (every PM cycle) are as shown below.

Section	Item	Remarks
Feed unit	Pickup roller (1st/2nd cassette)	
	Feed roller (1st/2nd cassette)	
	Drive gear (tooth face and shaft)	
	GCB bush bearing	
Bypass feed unit	Drive gear (tooth face and shaft)	
	GCB bush bearing	
Drum/Cleaner	Used toner auger drive section	
Developer unit	Oil seal (9pcs.)	
Transfer belt	Transfer belt power supply roller bearing and plastic bushing	
Exit/Reverse section	Drive gear	
	Bearing for GCB bushing	
	Bearing of plastic bushing	

### Replacement items (a)

The items that should be replaced at the timing of "R-a" (every PM cycle) are as shown below.

Section	Item	Remarks
Process related section	Ozone filter	
Main charger	Charger wire	*1
	Charger wire cleaning pad	
	Grid	*1
Drum/Cleaner	Photoconductive drum	
	Drum cleaning blade	
	Drum cleaning brush	
	Separation finger for drum	*1
Developer unit	Developer material	
	Toner filter	
Transfer belt	Transfer belt	
	Transfer belt cleaning brush	
	Transfer belt cleaning blade	
Fuser unit	Fuser roller	
	Pressure roller	
	Upper separation finger	
	Cleaning WEB	
	WEB pushing roller	
	Cleaning roller (felt)	
	Cleaning roller (metal)	
RADF	Pickup belt	
	Separation roller	
	Feed roller	

\*1: If a part is deformed or damaged, the part must be replaced immediately.

### Replacement items (b)

The items that should be replaced at the timing of "R-b" (PM cycle x2) are as shown below.

Section	Item	Remarks
Developer unit	Oil seal (9pcs.)	
Toner bag	Toner bag	

## Notes

- In the PM support mode, the names, replacement cycle, present number of copies/printouts and present operating time of PM parts can be displayed and checked on the touch panel screen. Parts whose present number of copies/printouts exceeds the replacement cycle number must be replaced immediately. After the part has been replaced, enter the PM support mode to reset the counter values of the replaced part, so that you can know the exact time when the next replacement should be carried out.
- The replacement cycles of the feed roller, pickup roller and separation roller in each paper feed unit are decided by the number of sheets sent from each feed unit. To know whether it is necessary to replace parts, go into the PM support mode to see the present number of paper fed from each feed unit and check this with the “replacement cycle” in the following table. The replacement cycle is common to all models.

Section	Item	Replacement cycle
1st Cassette	Feed roller	Every 200k sheets
	Pickup roller	
	Separation roller	
2nd Cassette	Feed roller	Every 200k sheets
	Pickup roller	
	Separation roller	
Tandem LCF	Feed roller	Every 200k sheets
	Pickup roller	
	Separation roller	
Bypass feed unit	Feed roller	Every 100k sheets
	Pickup roller	
	Separation roller	
Optional LCF (MP-4003L/A)	Feed roller	Every 200k sheets
	Pickup roller	
	Separation roller	

## H. Recommended Monthly Print/Copy Volume

e-STUDIO550	20k to 400k copies/month
e-STUDIO650	20k to 460k copies/month
e-STUDIO810	20k to 500k copies/month

## 6. Service Support

### A. TABS-Electronic Imaging Division, Service Organization

The TABS-EID National Service Department has reporting to it four regional service managers and their staffs of regional service specialists. It is the responsibility of these regional staffs to conduct technical training in Toshiba's various Digital Universities (TDU). Additionally, the regional service managers and their staffs support dealer service departments by providing, through scheduled or emergency visits, technical information, additional training, account assistance, and aid in the development of service department procedures.

The addresses and telephone numbers of Toshiba's regional offices are listed below along with a territory map that shows the area covered by each region.

<p>Northeast Region            959 Route 46 East, 5th Floor            Parsippany, NJ. 07054            Fax (973) 515-2298</p>	<p>Southeast Region            4855 Peachtree Industrial            Blvd Suite 210            Norcross, GA. 30092            Fax (770) 209-8555</p>	<p>Midwest Region            8770 W. Bryn Mawr Ave.            #700            Chicago, IL. 60631            Fax (773) 380-8610</p>	<p>Northwest Region            142 Technology#150            Irvine, CA. 92618            Fax (949) 753-0626</p>
--	---	---	--

### T.A.B.S. Service Support Territory Map

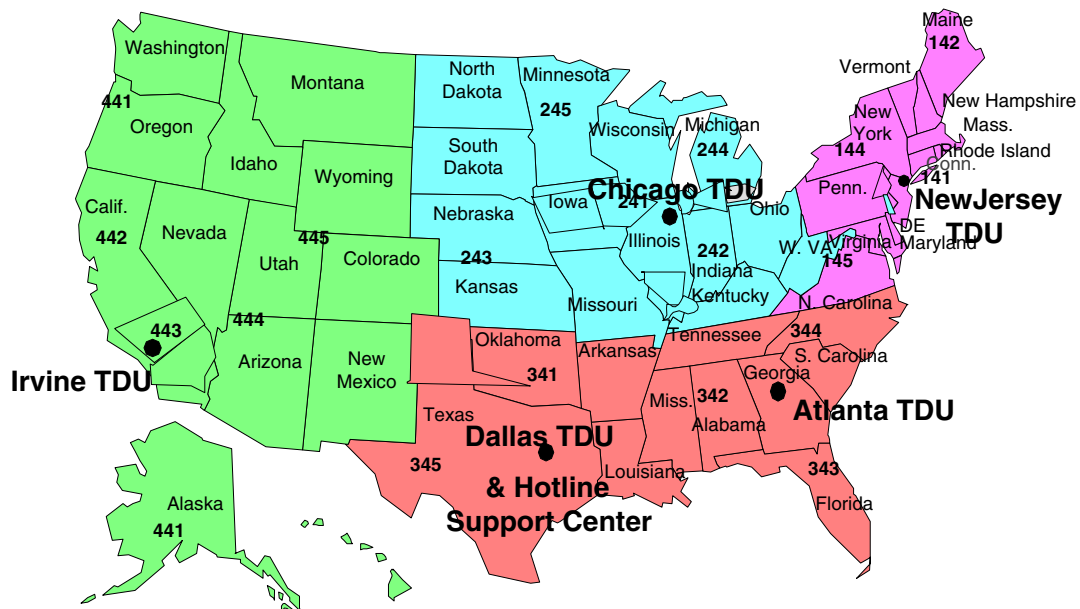

## **B. Service Policy**

Toshiba requires that its authorized dealers establish and maintain, in the dealers' approved territory, an adequately trained service staff and facilities for the maintenance and repair of Toshiba's copier, facsimile and printer products.

Before a dealer can receive delivery of its first machine of any particular model, one of the dealership's technicians must have successfully completed a Toshiba technical training program on that model. In addition, within ninety days, the dealer must have a second technician trained on the same model.

## **C. Internet FYI Portal - Training**

Toshiba America Business Solutions, Inc. provides its dealers Internet access 24 hours a day, 7 days a week to its service information system through Toshiba's FYI portal. This website provides online-access to:

- Course catalogs – an overview of courses eligible for enrollment and the prerequisite requirements.
- Course calendar – a current schedule by region for all classroom courses.
- Course registration – permits dealer service managers to enroll their technicians in various courses. The technicians must meet prerequisites in order to attend the courses.
- Enrollment status – provides the dealership access to the enrollment status of their technicians.
- Testing – on-line testing for all courses (CBT and classroom). Technicians must be registered in courses to access the tests.

## **D. Internet FYI Portal - TECH-TO-GO**

Via Toshiba's FYI Internet website, dealers can access Tech-To-Go, the company's service information system KnowledgeBase for Toshiba EID products. This comprehensive database of service information helps technicians troubleshoot specific symptoms or problems and provides recommendations on how to easily resolve customer issues. Tech-To-Go lets technicians search and scan documentation about specific product models and problems. These pages include on-line service manuals, downloads, utilities, patches, drivers, etc.

To ensure the best possible administrative support and training, we have structured the FYI portal as follows:

- The website address is <http://fyi.toshiba.com>
- To gain access to Toshiba's FYI website you must have an assigned user name and password. These can be obtained from the FYI administrator at your dealership.
- For Toshiba service training support, please contact Toshiba's Service System Administrator at 949-462-6812.
- For Toshiba FYI Portal technical support, please contact Toshiba's eBusiness Administrator at 949-462-6370.

## **E. Technical Support Hotline**

### **(1) Telephone Support:**

e-STUDIO550/650/810 telephone support for dealer technicians is available directly from Toshiba's Dallas Hotline Support Center.

### **(2) Telephone Number:**

Contact the Dallas Hotline Support Center, toll-free, at 888-879-8247 and select menu option 2 for the copier/fax hardware queue.

### **(3) Hours of Operation:**

From 8:00AM to 5:00PM in all local time zones.

### **(4) Hotline Support Requirements:**

When calling the Dallas Hotline Support Center, the calling technician must be trained on the product --- if he is not, the dealer service manager must place the call. The technician must be at the end-user's location and have the appropriate service-related documents and adjustment jigs.

To help navigate TABS Technical Telephone Support Hotline, the following flow chart shows the seven separate support areas technicians have access to when calling a single number for technical support.

# TABS TECHNICAL TELEPHONE SUPPORT

"YOUR PASSPORT TO TECH SUPPORT"

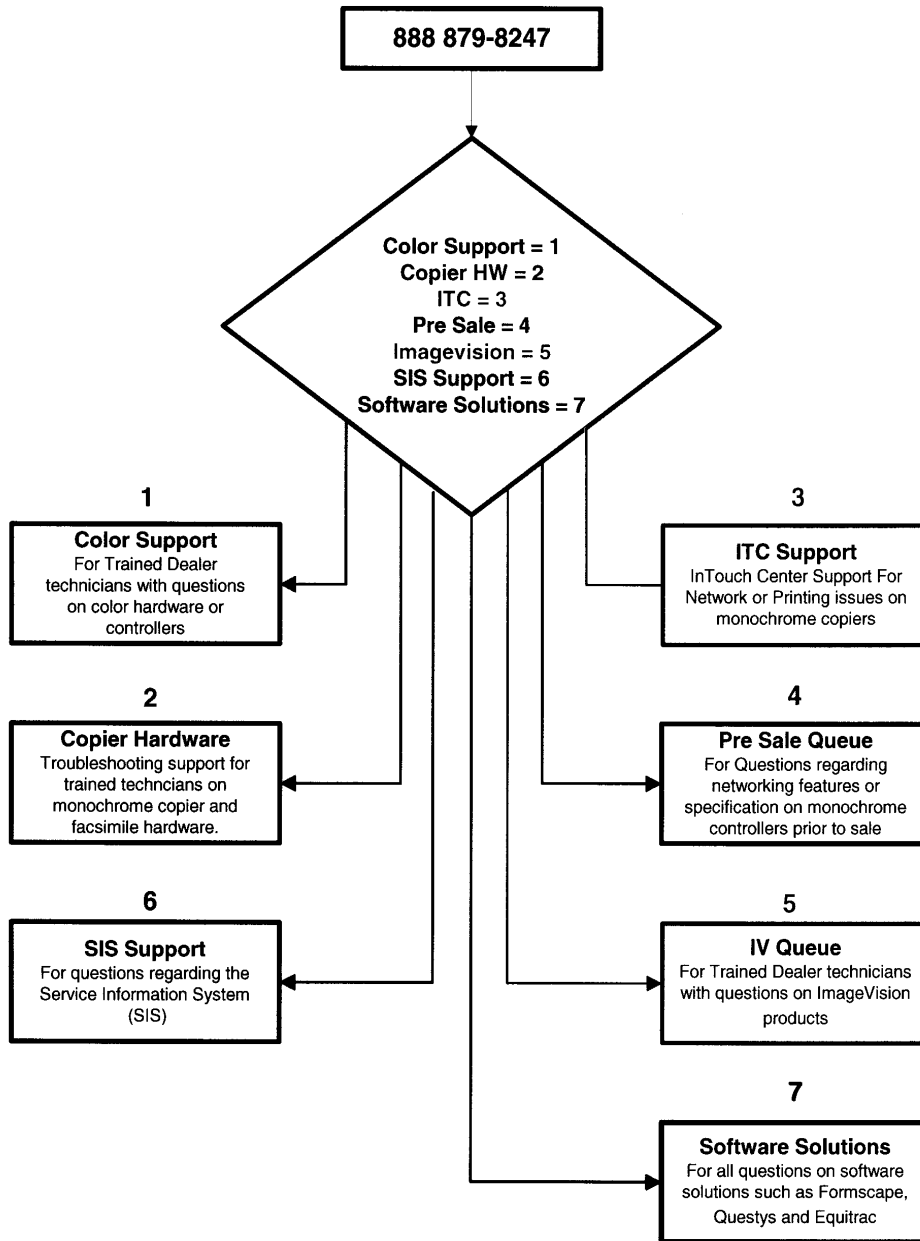

One number provides access to seven separate knowledgeable support areas.

Dealers can view support ticket status online. Support tickets may also be closed by fax or email, see the "Tech-To-Go" main page under "Permanent Announcements".

This information can also be found on "FYI":

Support Services/General Information/Service General Information/TABS Product Support Numbers.

## **F. On-Site Support**

### **(1) Dealer Support Visits:**

If an on-site field visit is needed to assist a dealer technician in resolving a technical issue, the dealer must coordinate the on-site field visit through the Dallas Hotline Support Center. The Center will contact the appropriate Toshiba regional service department and have the department contact the dealer.

### **(2) Scheduling of On-site Visits:**

A Toshiba regional specialist will coordinate time and travel arrangements with the requesting dealer. At the time of the visit, a technician trained on the product that is presenting the technical issue must be available. If a visit to the end-user's site is required, the trained technician (or dealer service manager) must accompany the Toshiba regional specialists.

## 7. Estimated Performance Data

### A. Maximum Monthly Copy Volume

Recommended maximum monthly copy volume is:

- e-STUDIO550 – Up to 400k/month
- e-STUDIO650 – Up to 460k/month
- e-STUDIO810 – Up to 500k/month

**B. Preliminary Supplies/Parts Yield Information and Service Expectations - eStudio 550/650/810**

	<u>eStudio550</u>	<u>eStudio650</u>	<u>eStudio810</u>
<b>PM Cycle =</b>	400,000	460,000	500,000
<b>Estimated MCBC* =</b>	23,610	33,112	38,381
<b>Estimated ART* =</b>	1.1	1.1	1.1

*\*ART includes repair time only.*

Description	Supply / Part Number	Estimated Yield - eStudio 550	Estimated Yield - eStudio 650	Estimated Yield - eStudio 810
<b>Supplies</b>				
Toner	T6510	60,100	60,100	60,100
Toner Bag	TB6510	800,000	920,000	1,000,000

**Service Parts**

OD6510	6LA23006000	400,000	460,000	500,000
MO KIT 8110	will advise	400,000	460,000	500,000
FR KIT 8110	will advise	400,000	460,000	500,000
MA KIT 8110	will advise	400,000	460,000	500,000
DF KIT 8110	will advise	500,000	500,000	500,000
ROLKIT81	will advise	200,000	200,000	200,000
ROLKIT4003	will advise	200,000	200,000	200,000

**USP (service module) information not yet available. WILL ADVISE.**

**NOTE:** Each machine ships with one drum included (please factor this when calculating cost-per-copy).

Please use the appropriate pricing levels as they pertain to your dealership, to determine parts and supply costs.

\*Service figures shown above (MCBC/ART) are estimates; no field data is currently available. Numbers used are based on copy volumes of average expectations for said speed machines.

## 8. Technical Training-Digital Copier

### A. Training Program

To service an e-STUDIO550/650/810, a dealer technician must attend an e-STUDIO550/650/810 Technical Training School. Classes are available at all Toshiba Digital Universities. At the successful completion of the training, technicians will be officially certified to service, repair and maintain the e-STUDIO550, e-STUDIO650 and e-STUDIO810 digital copiers. This training program does not cover controllers.

#### Note

The training program for GA-1140 and GL-1020 controllers for the e-STUDIO550/610/810 is discussed in Section 11 under Appendix --Optional Controller Features.

### B. Who Should Attend Training

All technicians who meet class prerequisites are eligible to attend this training.

### C. Training Prerequisites

All technicians planning to attend Toshiba's e-STUDIO550/650/810 Technical Training School must have successfully completed the following prior to enrolling through Toshiba's FYI portal:

- Level 1-Technical Preparation Course Workbook (LEV-1WB)
- e-STUDIO550/650/810 STEP Program (CD part #: V8110X-0206P)

#### Note

The e-STUDIO550/650/810 STEP Program is also available as a web-based training program and can be accessed directly through FYI. A memo discussing the e-STUDIO550/650/810 web-based STEP Program will be posted on FYI under "Announcements" ~ "Service". The web address link for the e-STUDIO550/650/810 web STEP Program will be indicated in the memo. The web address link will also be available on FYI under "Training" ~ "Service" ~ "STEP".

## D. What The Training Covers (Course Content)

Day	Module
Day 1	1 Orientation
	2 Unpacking and Setup
	3 Specifications
	4 Accessories Options Supplies
	5 Control Panel
	6 Error Codes
	7 Diagnostic Modes
	8 Component Identification
Day 2	9 Homework and Review
	10 Digital Copier Overview
	11 Scanner Unit
	12 Image Processing
	13 Laser Unit
	14 Process Related
Day 3	15 Homework and Review
	16 Drum/Cleaner Unit
	17 Developer Unit
	18 Transfer/Transport
	19 Power Supply
	20 Quiz
Day 4	21 Homework and Review
	22 Fuser Unit
	23 Paper Feed and Tandem LCF
	24 Reversing Unit & ADU
	25 Large Capacity Feeder
	26 Reversing Document Feeder
	27 Finishers, Hole Punch and Inserter
Day 5	28 Homework and Review
	29 Miscellaneous Codes
	30 ROM Updates
	31 Printer Board Option
	32 Review/ Final Exam and Wrap-Up

## **E. Training Locations**

The e-STUDIO550/650/810 class will be taught at all Toshiba Digital Universities.

- Irvine, CA.
- Atlanta, GA.
- Parsippany, NJ.
- Dallas, TX.
- Chicago, ILL.

Classroom instruction is provided by experienced Toshiba regional specialists who have been trained in the latest classroom platform skills and teaching techniques by Practical Management Incorporated (PMI), a leading company in train-the-trainer development. Toshiba regional specialists have a high degree of experience and technical knowledge on Toshiba products. They not only teach the technical courses, they also are responsible for resolving difficult technical problems when providing on-site support.

## **F. Training Format**

The e-STUDIO550/650/810 school is five days long. A ratio of two technicians per machine is provided at all Toshiba Digital Universities as are full system machine configurations including all optional accessories. Technicians perform numerous hands-on exercises giving them in-depth and practical knowledge of the machine and its internal workings. This knowledge is augmented by informative lectures that clarify complicated processes and procedures. At the end of the class, technicians are required to complete a rigorous testing process to demonstrate what they've learned and to prove their technical skills.

## G. Training Equipment

- e-STUDIO810
- MJ-7001 Inserter
- MJ-6003 Hole Punch
- MJ-1018 Saddle Stitch/Finisher
- MP-4003 LCF

## H. Documentation

The following manuals will be posted on Toshiba's FYI website under "Tech-To-Go", "Copier", "Active Models", "e-STUDIO550" or "e-STUDIO650" or "e-STUDIO810". However, for the purpose of training, these manuals will be distributed to technicians during the e-STUDIO550/650/810 class. Dealers will be charged for all documentation distributed in class.

Description	Part Number
e-STUDIO550/650/810 Service Manual	31100202
e-STUDIO550/650/810 Service Handbook	31110201
e-STUDIO550/650/810 Parts List	31130201
e-STUDIO550/650/810 Operator's Manual	-
MJ-1017/1018/6003/7001 Finisher Service Manual	31100204
MJ-1017/1018/6003 Parts Lists	31130202
MJ-7001 Inserter Parts Lists	31130204
MJ-4003 LCF Service Manual	31100203
MJ-4003 LCF Parts Lists	31130203

## I. Unique Tools and Adjustment Jigs

Following is a list of unique adjustment jigs (not used on other models) for the e-STUDIO550/650/810. One set of these jigs is given to each technician attending e-STUDIO550/650/810 school. Dealers will be billed at stated prices.

The jigs will be given only to the first technician trained from the designated dealer, because only one set per dealer is required. Additional jigs can be ordered through EID's standard parts ordering procedure or via FYI.

Description	Part Number
RADF Adjustment Pin	6LA09445000
Lens Unit Adjustment Pin	4406322350
Wire Holding Tool	6LA01757000

During e-STUDIO550/650/810 classroom training, if a technician has not been previously trained on the e-STUDIO3500/4500, the following additional tools and jigs will be provided to the technician and the dealer will be billed accordingly.

Description	Part Number
Interlock	4407915730
Update Board (Logic/Scan)	44205829000
Update Board (System)	44205828000
Test Chart	4408687180

## **J. Dealer-Administered Technical Education Program (DATE)**

Toshiba's Dealer-Administered Technical Education Program will be available for the e-STUDIO550/650/810 class.

To be a DATE Program participant, a dealer must have on file a current DATE Program Policy and Procedures Acknowledgment for the specified location. The criteria to be a DATE dealer is detailed in the Acknowledgment, however, below are some of the basic requirements:

- The dealer must be active with a current Dealer Agreement.
- A minimum classroom size of approx. 450 sq. ft is required to accommodate four technicians and two fully configured systems. Larger classes with added technicians call for an additional 90-square -feet per technician.
- The designated dealer instructor must possess a minimum of three years experience repairing and maintaining copiers.
- The dealer instructor must have successfully completed one of the train-the-trainer courses recommended by Toshiba.
- The dealer instructor must achieve a final grade score of 90 percent or better to be allowed to teach the same DATE Program.

## **9. Service Requirements**

### **A. Service Authorization**

Toshiba requires its dealers to establish and maintain an adequately trained service staff and on-site facilities for field maintenance and repair of its copier, facsimile and printer products in the dealers approved territory.

Before a dealer can receive delivery of the first machine of any particular model, one of the dealership's technicians must successfully complete a Toshiba technical training program on that specific model. In addition, the dealer must have a second technician trained on the same model within ninety days of the first training.

### **B. Service Recommendations**

To properly service and maintain e-STUDIO550/650/810 digital copiers, Toshiba strongly recommends that technicians carry with them a PC laptop computer. Laptops are used as tools and allow technicians to periodically update machines and accessories to the latest firmware versions. Toshiba also suggests the PC laptop include a CD-ROM drive giving the technicians the ability to use many of the CD-ROM service support programs such as COSMOS (Service Manuals and Handbooks in PDF format on CD's) and RIBON (Spare Parts List on CDs).

Toshiba also recommends that technicians have access to the Internet to view the latest technical data and up-to-date problem resolutions posted on Toshiba's FYI website.

# 10. Warranty

## A. Warranty Policy

All new Toshiba products purchased by a dealer are subject to a ninety (90) day limited warranty given by TABS (all used products are sold "as is"). The new product warranty, which runs to the end-user, is as follows:

## B. Toshiba America Business Solutions, Inc. Limited Warranty

Toshiba America Business Solutions, Inc. (TABS) warrants that this machine, upon delivery by TABS or an authorized TABS dealer to a retail customer, will be in new condition and free from defects in material and workmanship for 90 days after delivery. This warranty is void (a): if the machine is used under other than normal use and maintenance conditions, (b): if the maintenance as set forth in TABS's maintenance literature is not performed, (c): if the machine is modified or altered, unless the modification or alteration is expressly authorized by TABS, (d): if the machine is subject to abuse, neglect or accident, (e): if it is repaired by someone other than TABS or an authorized TABS dealer, (f): if the serial number of the machine is defaced or missing, (g): if the retail customer uses non-TABS supplies and such supplies cause abnormal service calls or are unacceptable for use with the machine or are defective.

The sole obligation of TABS or Toshiba Corporation under this warranty, or under any other legal obligation with respect to the machine, is the repair or replacement by TABS, or its authorized dealer, with new or remanufactured parts (at their option), of such defective or missing parts as are causing the malfunction. If TABS or one of its authorized dealers does not replace or repair such parts, the retail customer's sole remedy will be a refund of the selling price of such parts as are proven to be defective and which are returned to TABS or one of its authorized dealers within the warranty period.

Under no circumstances will the retail customer or any user or dealer or other person be entitled to any direct, special, indirect or consequential damages, for breach of contract, tort, or otherwise. Under no circumstances will any such person be entitled to any sum greater than the purchase price paid for the machine.

To obtain service under this warranty, the retail customer must bring the malfunction of the machine to the attention of TABS or one of its authorized dealers within the 90 day period. Failure to bring the malfunction to TABS's attention, or to the attention of an authorized TABS dealer, within the prescribed time, results in the customer not being entitled to warranty service.

THERE ARE NO OTHER WARRANTIES FROM EITHER TOSHIBA AMERICA BUSINESS SOLUTIONS, INC. OR TOSHIBA CORPORATION WHICH EXTEND BEYOND THE FACE OF THIS WARRANTY. ALL OTHER WARRANTIES EXPRESSED OR IMPLIED, INCLUDING THE WARRANTIES OF MERCHANTABILITY, FITNESS FOR A PARTICULAR PURPOSE, AND FITNESS FOR USE, ARE EXCLUDED.

No TABS dealer and no person other than an officer of TABS may extend this warranty, nor may they modify it in any respect. No modification or extension is effective unless it is in writing.

Neither dealer nor any other person may extend TABS' limited warranty or modify it in any respect. No modification or extension of TABS's limited warranty is effective unless it is in a writing and signed by TABS' Vice President, General Manager, Electronic Imaging Division.

TABS warrants to Dealer that each new Product will be free from defects in material and workmanship for a period of ninety (90) days after the delivery of the product to Dealer by TABS or until delivery by Dealer to an end-user, whichever occurs first. DEALER'S WARRANTY IS SUBJECT TO THE SAME LIMITATIONS AND EXCLUSIONS (INCLUDING THOSE EXCLUDING MERCHANTABILITY) AS THE END-USER'S LIMITED WARRANTY (SEE PARAGRAPH 12 ABOVE). Dealer shall notify TABS of any claimed defect in any Product or related goods within thirty (30) days of its occurrence, by the giving of a written report setting forth all pertinent details including a description of the defect and the time and place of occurrence.

If Dealer elects to give a warranty to an end-user greater than the TABS limited warranty, Dealer must make it clear to the end-user that that warranty is being given only by Dealer and not by TABS.

To make certain that end-users understand the warranty coverage they are receiving from TABS, a sticker or other writing containing the TABS limited warranty may be affixed by TABS to products. Dealer may not remove such a sticker or writing. Dealer shall make certain that the sticker or writing is on each Product in its showroom and on the product upon delivery and installation; if a sticker or writing is missing, it is the Dealer's responsibility to replace it with a new one. Dealer shall obtain from TABS and stock an adequate supply of stickers or warranty writings.

Dealer shall make certain that all end-users are aware of the terms of the TABS limited warranty and of the maintenance requirements of Products prior to the sale of the products to an end-user.

Dealer is responsible for performing whatever warranty service an end-user (which purchased from Dealer) deserves under the TABS limited warranty. TABS's sole responsibility to the Dealer is to supply to Dealer without charge such replacement parts as are necessary, in accordance with the procedures set forth in TABS's parts warranty policy, which TABS may establish from time to time. If requested by TABS in writing, Dealer shall also be obligated to perform warranty service for Authorized Products or other Products in the territory, sold or marketed by persons other than Dealer, for which Dealer will be compensated in accordance with TABS's standard warranty compensation schedules then in effect.

Replacement parts and related goods will carry only such warranty (which shall be subject to such limitations and exclusions) as TABS may announce in writing and change from time to time.

Dealer and TABS agree TABS reserves the right at any time to amend or modify its warranty policy for end-users or for Dealers, including any limitations or exclusions applicable thereto, provided that such is done in writing, signed by TABS's Vice President, General Manager, Electronic Imaging Division.

If Dealer does not follow TABS's warranty policy, Dealer shall be legally responsible for any damages or expenses that arise beyond those expressly owed by TABS under its warranty policy.

# 11. Appendix — Optional Controller Features

## A. Each Controller in Market Map

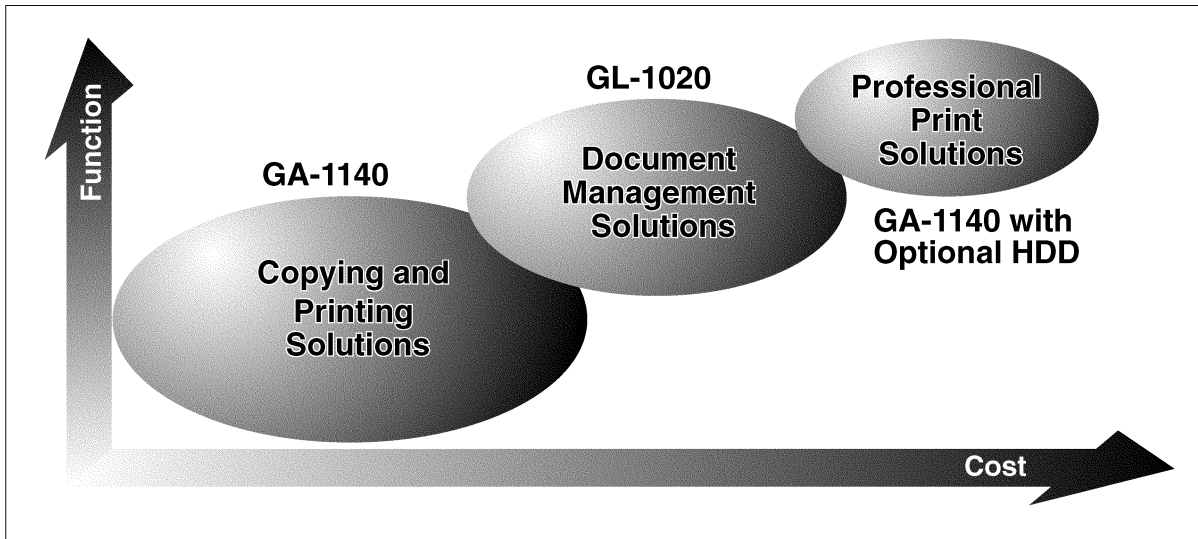

### GA-1140:

Low cost and entry level controller for the general office market.

- Supports only the necessary printing function for the general office.
- Enables to upgrade the functions due to installation of the options such as PS upgrade (GE-1020), etc.

### GL-1020:

Feature rich and expandable controller for the general office market.

- Supports the functions for scanning, filing, Internet connection, editing and printing.
- Enables to manage the integrated paper and electric documents.

### GA-1140 with

#### Optional HDD (GE-1060):

Sophisticated and professional level controller for the production print market.

- Targets the print for pay market and POD market.
- The professional EFI applications such as Command WorkStation 4.0, DocBuilder, etc. are bundled.

## B. Controller Functions

Item	GA-1140	GL-1020	GA-1140 with HDD
OS	Linux	Linux	Linux
Device management utility	TopAccess	TopAccess *Scan functions supported	TopAccess *Scan functions supported
Device monitoring tool	Job Monitoring Tool	GL-DocMon	Job Monitoring Tool
Application	—	—	Command WorkStation 4.0 Fiery FreeForm Fiery WebTools DocBuilder DocBuilder Pro 1.5 *Option
Printing functions			
Printing services			
SMB	Yes	Yes	Yes
LPR/LPD	Yes	Yes	Yes
IPP	Yes	Yes	Yes
NetWare NDS (PSERVER or RPRINTER)	Yes	Yes	Yes
NetWare Bindery (PSERVER or RPRINTER)	Yes	Yes	Yes
NetWare NDPS	No	Yes	Yes
Port 9100	Yes	Yes	Yes
AppleTalk	Yes *with PS3 upgrade (GE-1020)	Yes	Yes
Paper handling			
Staple *with Finisher(MJ-1017/1018)	Yes	Yes	Yes
Saddle stitch *with Finisher(MJ-1018)	Yes	Yes	Yes
Hole punch *with Finisher(MJ-1018)	Yes	Yes	Yes
Duplex	Yes	Yes	Yes
Mixed paper size	Yes	Yes	Yes
Cover sheets	Yes	Yes	Yes
Sheet insertion	Yes	Yes	Yes
Sheet insertion from inserter *with Inserter(MJ-7001)	Yes	Yes	Yes
Tab paper feeding/insertion	Yes	Yes	Yes

Layout/Editing				
Overlay		No	Yes	No
Watermark		Yes	Yes	Yes
N-up printing		Yes	Yes	Yes
Magazine sort		Yes	Yes	Yes
Print on tab		Yes	Yes	Yes
Variable data printing		No	No	Yes
Imposition		No	No	Yes
Job retention				
Private print		Yes	Yes	Yes
Proof print		Yes	Yes	Yes
Scheduled print		No	Yes	No
Stored job print		Yes	No	Yes
Storing into TopAccess composer		No	Yes	No
Cluster printing		Yes *with Velocity software	No	Yes *with Velocity software
Department codes		Yes	Yes	Yes
Job refusing		No	Yes *by department code	Yes *by Command WorkStation member printing
Scanning functions				
Scan to TWAIN		No	Yes	Yes
Scan to file		No	Yes	Yes
Destination	Local drive	—	Yes	Yes *Mailbox
	File server	—	Yes	No
File format		—	TIFF, PDF	TIFF, PDF
Scan to print		No	No	Yes
Scan to stored job		No	No	Yes
Scan to E-mail		No	Yes	Yes
File format		—	TIFF, PDF	TIFF, PDF
Protocol	SMTP	—	Yes	Yes
	MIME	—	Yes	Yes
	POP3	—	Yes	Yes *POP3/IMAP
LDAP support		—	Yes	No
URL attached		—	No	Yes
Address book access entry		—	Yes	Yes

Scan to Internet FAX		No	Yes	No
File format		—	TIFF	—
Scan to Application		No	Yes <small>*Scan to TopAccess composer</small>	Yes <small>*Scan to DocBuilder PRO1.5</small>
Job template		No	Yes <small>*Via TopAccess</small>	Yes <small>*Via Control panel</small>
Job notification via E-mail		No	Yes	Yes
Network/Device management functions				
Device configuration setting		Yes *1	Yes *1	Yes *1, *2, *3
Device status checking		Yes *1	Yes *1	Yes *1, *2, *3
Network configuration setting		Yes *1	Yes *1	Yes *1, *2, *3
Counter checking		Yes *1	Yes *1	Yes *1
Remote department code setting		Yes *1	Yes *1	Yes *1
Font downloading		No	No	Yes *2, *3
Job management functions				
Job Monitoring	Paper level	Yes *1, *4, *5	Yes *1, *4	Yes *1, *4, *5
	Toner level	Yes *1, *4, *5	Yes *1, *4	Yes *1, *4, *5
	Job queue	Yes *1, *4	Yes *1, *6	Yes *1, *2, *4
	Error	Yes *1, *4	Yes *1, *6	Yes *1, *2, *4
	Completion	Yes *1, *4	Yes *1, *6	Yes *1, *2, *4
Event notification window popup		Yes *4	Yes *6	Yes *4
E-mail notification		No	Yes	Yes
Override current job option		No	No	Yes *2, *4
Delete job and cancel processing		No	Yes *1, *7	Yes *2, *4
Duplicate or rename job		No	No	Yes *2, *4
RIP a job and hold the raster data		No	No	Yes *2, *4
Change the priority of jobs		No	No	Yes *2, *4
Edit and merge raster data job		No	Yes *7	Yes *2, *3
Job log		Yes *1	Yes *1	Yes *1, *2, *3
Job submission via web utility		No	No	Yes *3
Job archiving		No	No	Yes *2
Job re-route (Load balancing)		No	No	Yes *2

\*1: Via TopAccess

\*2: Via Command WorkStation

\*3: Via Fiery WebTools

\*4: Via Job Monitoring Tool

\*5: Via Printer driver

\*6: Via GL-DocMon

\*7: Via TopAccess Composer

## C. GA-1140 Specifications

### System requirements

The GA-1140 print controller operates in the following environment.

#### ◆ Connector cable

For Local Environment:

Be sure to use correct type of cable.

- IEEE-1284 printer cable (Compatible mode, ECP)

For Network Environment:

Be sure to use the correct type of cable and network device for your network interface card.

- 10BASE-T/100BASE-TX  
STP cable with a Category 5 RJ-45 connector

#### ◆ For Windows

This machine can be used in local mode via a parallel printer cable, on a network via TCP/IP or IPX/SPX.

- Hardware

Display Resolution: 1024 x 768 dots or more

Display Color: High Color (16bit) or higher is recommended

CPU: 80486, AMD, or Pentium processor

Memory:	Windows 95:	16MB or more
	Windows 98:	24MB or more
	Windows Me and Windows NT 4.0:	32MB or more
	Windows 2000 and Windows XP:	64MB or more

- OS

Microsoft Windows 95 Operating System, English Version

Microsoft Windows 98 Operating System, English Version

Microsoft Windows Me Operating System, English Version

Microsoft Windows NT Workstation Operating System 4.0 with Service Pack 6 or higher, English Version

Microsoft Windows NT Server Network Operating System 4.0 with Service Pack 6 or higher, English Version

Microsoft Windows 2000 Professional Operating System with Service Pack 2 or higher, English Version

Microsoft Windows 2000 Server Operating System with Service Pack 2 or higher, English Version

Microsoft Windows XP Home Edition Operating System, English Version

Microsoft Windows XP Professional Operating System, English Version

#### ◆ For Macintosh

This machine can be used on the network via AppleTalk (Ethernet).

- Hardware  
Display Resolution: 1024 x 768 dots or more
- OS  
Mac OS 8.6 to 9.2, Mac OS X (Classic Mode only)

#### ◆ TopAccess

TopAccess can be used in the following environment:

- Applicable OS: Windows 95, Windows 98, Windows Me, Windows NT 4.0, Windows 2000, Windows XP, and Mac OS 8.6 or higher
- WWW Browser: Netscape Communicator 4.5 or higher, and Java enabled or Microsoft Internet Explorer 5.5 and Service Pack 2, or higher with Java enabled.
- Protocol: TCP/IP

#### ◆ Network server

Printing can be performed with the following network servers:

- TCP/IP network: Windows NT 4.0, Windows 2000
- IPX/SPX network: NetWare 3.x, 4.x, or 5.x

## **Applications**

### **◆ Command WorkStation**

Command WorkStation completes or changes most setup options, and manages the print jobs stored on the GA-1140 hard disk from a Windows computer.

This software also provides the FreeForm features that allows you to create the master-element and variable-element documents using any application you wish. The two documents can be created using different applications, or even different computer platforms. To create the master-elements document, you can use a page layout or graphics application. To create the variable-elements document, you can use a word processing application that has a mail merge feature, a page layout application that supports scripting, or a database application.

This software also allows you to access the other additional option such as DocBuilder Pro.

### **◆ Fiery FreeForm**

Fiery FreeForm stores RIPped formats and allows you to integrate variable data for printing. This tool has the advantage of greatly lowering RIP data volumes—thus maximizing output speed.

### **◆ Fiery WebTools**

Fiery WebTools manage the GA-1140 remotely from the Internet or from your company's intranet. These Tools can be accessed from the TopAccess using the Internet browser, which you can select a variety of functions, including Status, WebSpooler, WebLink, Installer, WebDownloader, WebSetup, and WebScan.

### **◆ DocBuilder/DocBuilder PRO**

DocBuilder assembles data created on multiple applications, and also reorders and removes RIPped data pages on the thumbnail views with drag and drop. This tool simplifies professional document editing and print jobs.

Optional DocBuilder Pro GB-1160 is the professional version of RIPped data editing software. This application offers advanced imposition and editing functions for binding with print data stored in the controller.

## D. GL-1020 Specifications

### System requirements

The GL-1020 document controller operates in the following environment.

#### ◆ Connector cable

For Network Environment:

Be sure to use the correct type of cable and network device for your network interface card.

- 10BASE-T/100BASE-TX  
STP cable with a Category 5 RJ-45 connector

#### ◆ For Windows

This machine can be used on the network via TCP/IP or IPX/SPX.

- Hardware

Display Resolution:	800 x 600 dots or more
Display Color:	High Color (16bit) or higher is recommended
CPU:	80486, AMD, or Pentium processor
Memory:	32MB or more
HDD disk space:	100MB or more
CD-ROM drive:	Available

- OS

Microsoft Windows 95 Operating System with WinSock 2.0, English Version

Microsoft Windows 98 Operating System, English Version

Microsoft Windows Me Operating System, English Version

Microsoft Windows NT Workstation Operating System 4.0 with Service Pack 5 or higher, English Version

Microsoft Windows NT Server Network Operating System 4.0 with Service Pack 5 or higher, English Version

Microsoft Windows 2000 Professional Operating System with Service Pack 1 or higher, English Version

Microsoft Windows 2000 Server Operating System with Service Pack 1 or higher, English Version

Microsoft Windows XP Home Edition Operating System, English Version

Microsoft Windows XP Professional Operating System, English Version

#### ◆ For Macintosh

This machine can be used on the network via AppleTalk (Ethernet).

- Hardware  
Display Resolution: 800 x 600 dots or more
- OS  
Mac OS 8.0, 8.5, 8.6, 9.0, Mac OS X
- Software  
LaserWriter 8.6.5 or higher printer driver  
StuffIt compression software version 5.0 or higher

#### ◆ For UNIX

This machine can be used on the network via TCP/IP or IPX/SPX.

- Hardware  
Platform: SPARC platform  
PA-RISC platform  
RS/6000 platform  
Display Resolution: 800 x 600 dots or more
- OS  
HP-UX version 10.2 or 11.0  
Sun Solaris version 2.5x, 2.6, 7.0 or 8.0  
IBM AIX 4.3x  
Linux 7.x

#### ◆ TopAccess

TopAccess can be used in the following environment:

- Applicable OS: Windows 95, Windows 98, Windows Me, Windows NT 4.0, Windows 2000, Windows XP, Mac OS 8.x or higher, HP-UX, and Solaris.
- WWW Browser: Netscape Communicator 4.75 or higher (Windows)  
Netscape Communicator 4.76 or higher (UNIX)  
Netscape Communicator 4.78 or higher (Macintosh)  
Microsoft Internet Explorer 5.0 or higher (Windows, Macintosh, UNIX)
- Protocol: TCP/IP

#### ◆ Network server

Printing can be performed with the following network servers:

- TCP/IP network: Windows NT 4.0, Windows 2000
  
- IPX/SPX network: NetWare 4.x, 5.x, or 6.x

#### Applications

##### ◆ GL-DocMon

GL-DocMon provides end-users with a way of monitoring all jobs and controlling their own current jobs on the controller. With the notification feature enabled, end users are informed of copier or printing events, such as paper-out or cassette open, before they walk to the copier only to find their job incomplete or unsuccessful. GL-DocMon also provides a menu link to the TopAccess web utility in end-user mode.

## **E. Service Support**

### **Service Policy**

Toshiba requires that its authorized dealers establish and maintain, in the dealers' approved territory, an adequately trained service staff and facilities for the maintenance and repair of Toshiba's copier/controller, facsimile and printer products.

Before a dealer can receive delivery of its first machine of any particular model, one of the dealership's technicians must have successfully completed a Toshiba technical training program on that model. In addition, within ninety days, the dealer must have a second technician trained on the same model.

### **Internet FYI Portal - Training**

Toshiba America Business Solutions, Inc. provides its dealers Internet access 24 hours a day, 7 days a week to its service information system through Toshiba's FYI portal. This website provides online-access to:

- Course catalogs – an overview of courses eligible for enrollment and the prerequisite requirements.
- Course calendar – a current schedule by region for all classroom courses.
- Course registration – permits dealer service managers to enroll their technicians in various courses. The technicians must meet prerequisites in order to attend the courses.
- Enrollment status – provides the dealership access to the enrollment status of their technicians.
- Testing – on-line testing for all courses (CBT and classroom). Technicians must be registered in courses to access the tests.

## **Internet FYI Portal - TECH-TO-GO**

Via Toshiba's FYI Internet website, dealers can access Tech-To-Go, the company's service information system KnowledgeBase for Toshiba EID products. This comprehensive database of service information helps technicians troubleshoot specific symptoms or problems and provides recommendations on how to easily resolve customer issues. Tech-To-Go lets technicians search and scan documentation about specific product models and problems. These pages include on-line service manuals, downloads, utilities, patches, drivers, etc.

To ensure the best possible administrative support and training, we have structured the FYI portal as follows:

- The website address is <http://fyi.toshiba.com>
- To gain access to Toshiba's FYI website you must have an assigned user name and password. These can be obtained from the FYI administrator at your dealership.
- For Toshiba service training support, please contact Toshiba's Service System Administrator at 949-462-6812.
- For Toshiba FYI Portal technical support, please contact Toshiba's eBusiness Administrator at 949-462-6370.

## **Technical Support Hotline**

### **(1) Telephone Support:**

GA-1040 and GA-1140 telephone support for dealer technicians is available directly from Toshiba's InTouch Center.

### **(2) Telephone Number:**

Contact the InTouch Center, toll-free, at 888-879-8247 and select menu option 3 for the InTouch Center B/W Controller queue.

### **(3) Hours of Operation:**

From 9:00AM to 5:00PM in all local time zones.

### **(4) Hotline Support Requirements:**

When calling the InTouch Center, the calling technician must be trained on the product --- if he is not, the dealer service manager must place the call. The technician must be at the end-user's location and have the appropriate service-related documents and adjustment jigs.

To help navigate TABS Technical Telephone Support Hotline, the following flow chart shows the seven separate support areas technicians have access to when calling a single number for technical support.

# TABS TECHNICAL TELEPHONE SUPPORT

"YOUR PASSPORT TO TECH SUPPORT"

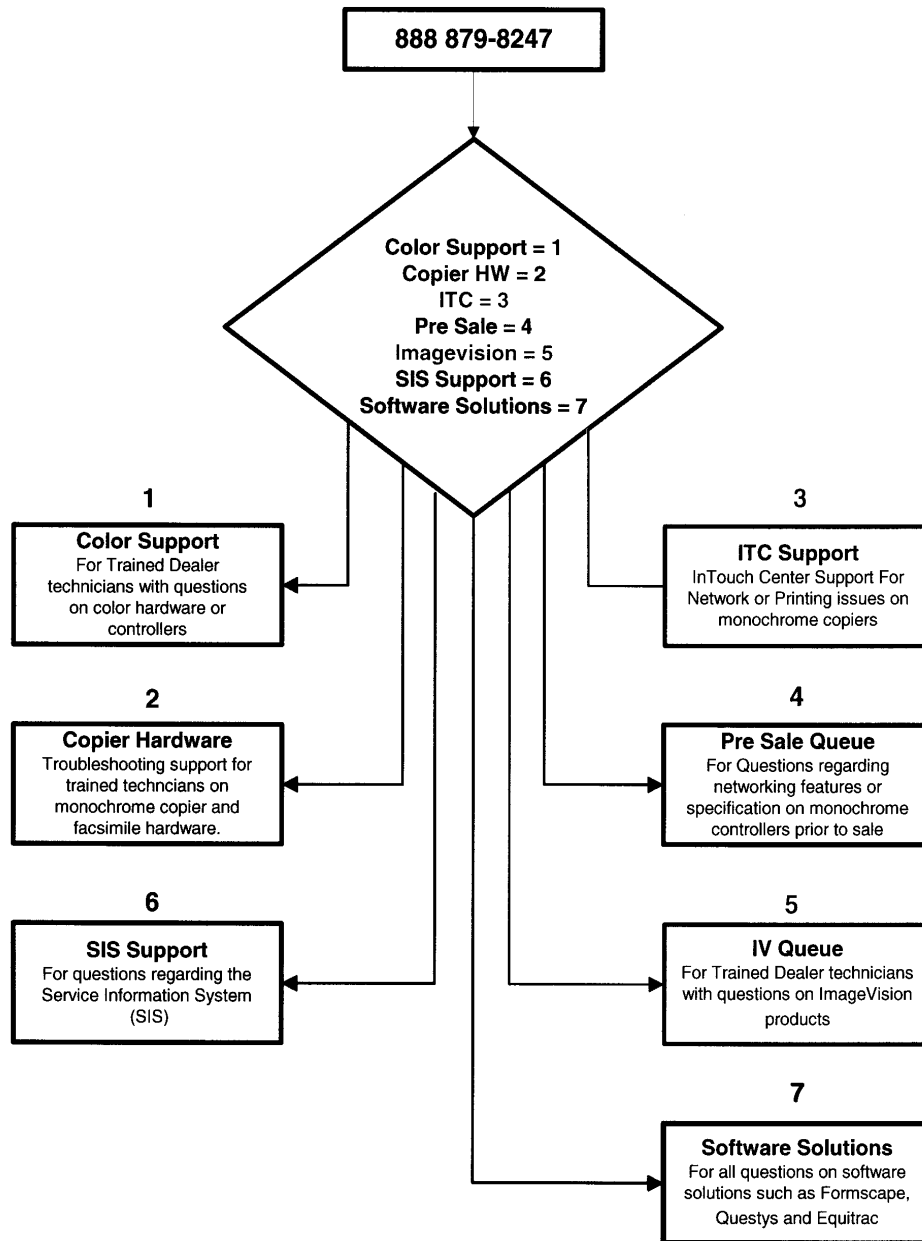

One number provides access to seven separate knowledgeable support areas.

Dealers can view support ticket status online. Support tickets may also be closed by fax or email, see the "Tech-To-Go" main page under "Permanent Announcements".

This information can also be found on "FYI":

Support Services/General Information/Service General Information/TABS Product Support Numbers.

## **On-Site Support**

### **(1) Dealer Support Visits:**

If an on-site field visit is needed to assist a dealer technician in resolving a technical issue, the dealer must coordinate the on-site field visit through the InTouch Center. The Center will contact the appropriate Toshiba regional service department and have the department contact the dealer.

### **(2) Scheduling of On-site Visits:**

A Toshiba regional specialist will coordinate time and travel arrangements with the requesting dealer. At the time of the visit, a technician trained on the product that is presenting the technical issue must be available. If a visit to the end-user's site is required, the trained technician (or dealer service manager) must accompany the Toshiba regional specialists.

## F. Technical Training- Controllers

### Training Program

To service an EFI GA-1140 Controller, a dealer must have a current GA-1040/GA-1110 certified technician (additional training for the GA-1140 alone is not required.) Dealers who do not have GA-1040/GA-1110 Controller certified technicians and wish to be certified on the GA-1140 will be required to attend a Controller Essentials (GA-1040 & GA-1140) class. Classes are available at all Toshiba Digital Universities. At the successful completion of the training, technicians will be officially certified to service, repair and maintain the EFI GA-1040 & GA-1140 Controllers.

### Who Should Attend Training

All technicians who meet class prerequisites are eligible to attend this training.

### Training Prerequisites

All technicians planning to attend Toshiba's Controller Essentials Technical Training School must have successfully completed **at least one** of the following prior to enrolling through Toshiba's FYI portal:

- A Novell CNA and/or CNE certificate. (We strongly recommend that a person having only a Novell CNA certification also possess a strong working knowledge of WINDOWS '95/98/2000 or WINDOWS NT.)
- An MCP certificate for Supporting WINDOWS 95/98/2000 and/or Supporting WINDOWS NT.
- A MCSE certificate
- A CompTia Network + certificate
- BTA ProTech Certification
- Completion of MindBuilder's CBT program titled "Plug It In."
- If a technician possesses long term work experience in an MIS/IT environment installing, configuring, and administering various network platforms, Toshiba offers the option of the technician taking a Networking Proficiency Exam for either Novell or NT.

## What The Training Covers (Course Content)

Day	Module
Day 1	1 Introduction
	2 Course Overview
	3 Networking Fundamentals
	4 GA-1140 Overview, Documents, Software
	5 GA-1140 Controller Hardware/Software Specs
	6 GA-1140 Network Specifications
Day 2	7 GA-1140 Network Servers
	8 GA-1140 Client Hardware/Software Specs
	9 GA-1140 Driver Installation (Win, Novell)
	10 GA-1140 Management
Day 3	11 GA-1140 Options
	12 Troubleshooting
	13 GA-1040 System Requirements
	14 GA-1040 Features
Day 4	15 GA-1040 Features (Cont.)
	16 Examination

## Training Locations

The Controller Essentials class will be taught at all Toshiba Digital Universities.

- Irvine, CA.
- Atlanta, GA.
- Parsippany, NJ.
- Dallas, TX.
- Chicago, ILL.

Classroom instruction is provided by experienced Toshiba regional specialists who have been trained in the latest classroom platform skills and teaching techniques by Practical Management Incorporated (PMI), a leading company in train-the-trainer development. Toshiba regional specialists have a high degree of experience and technical knowledge on Toshiba products. They not only teach the technical courses, they also are responsible for resolving difficult technical problems when providing on-site support.

## Training Format

The Controller Essentials School is four days long. A ratio of two technicians per machine/controller is provided at all Toshiba Digital Universities as are full system machine configurations including all optional accessories. Technicians perform numerous hands-on exercises giving them in-depth and practical knowledge of the machine/controller and its internal workings and configurations. This knowledge is augmented by informative lectures that clarify complicated processes and procedures. At the end of the class, technicians are required to complete a rigorous testing process to demonstrate what they've learned and to prove their technical skills.

## Training Equipment

- e-STUDIO810
- EFI GA-1040 Controller
- EFI GA-1140 Controller

## Documentation

The following manuals will be posted on Toshiba's FYI website under "Tech-To-Go", "Copier", "Active Models", "GA-1040" or "GA-1140". However, for the purpose of training, these manuals will be distributed to technicians during the Controller Essentials class. Dealers will be charged for all documentation distributed in class.

Description	Part Number
GA-1140 Service Guide	GA1140001
GA-1140 Administrator's Guide	GA1140002
GA-1140 User's Guide	GA1140003
GA-1140 Quick Start Guide	GA1140004
GA-1140 Fiery Utilities Guide	GA1140005
GA-1140 Scan & E-mail Service Guide	GA1140006
GA-1040 Configuration Guide	GA1040001
GA-1040 Getting Started Guide	GA1040002
GA-1040 Printing Guide	GA1040003
GA-1040 Job Management Guide	GA1040004

### **Controller Service Kits**

Following is a list of unique Controller Service Kits (not used on other models) for the GA-1040 and GA-1140. One set of these kits is given to each technician attending Controller Essentials School. Dealers will be billed at stated prices.

Additional kits can be ordered through EID's standard parts ordering procedure or via FYI.

<b>Description</b>	<b>Part Number</b>
GA-1040 CD Service Kit	45016848
GA-1040 Media Kit	45018041
GA-1140 Service Kit	45028763

### **Dealer-Administered Technical Education Program (DATE)**

Toshiba's Dealer-Administered Technical Education Program will not be available for the Controller Essentials class. However, if the dealership desires to participate in the DATE Program, the following is a brief outline of the program requirements.

To be a DATE Program participant, a dealer must have on file a current DATE Program Policy and Procedures Acknowledgment for the specified location. The criteria to be a DATE dealer is detailed in the Acknowledgment, however, below are some of the basic requirements:

- The dealer must be active with a current Dealer Agreement.
- A minimum classroom size of approx. 450 sq. ft is required to accommodate four technicians and two fully configured systems. Larger classes with added technicians call for an additional 90-square -feet per technician.
- The designated dealer instructor must possess a minimum of three years experience repairing and maintaining copiers.
- The dealer instructor must have successfully completed one of the train-the-trainer courses recommended by Toshiba.
- The dealer instructor must achieve a final grade score of 90 percent or better to be allowed to teach the same DATE Program.

## **G. Service Requirements**

### **Service Authorization**

Toshiba requires its dealers to establish and maintain an adequately trained service staff and on-site facilities for field maintenance and repair of its copier/controller, facsimile and printer products in the dealers approved territory.

Before a dealer can receive delivery of the first machine/controller of any particular model, one of the dealership's technicians must successfully complete a Toshiba technical training program on that specific model. In addition, the dealer must have a second technician trained on the same model within ninety days of the first training.

### **Service Recommendations**

To properly service and maintain the EFI GA-1040 and GA-1140 Controllers, Toshiba strongly recommends that technicians carry with them a PC laptop computer. Laptops are used as tools and allow technicians to periodically update machines, controllers and accessories to the latest firmware versions. Toshiba also suggests the PC laptop include a CD-ROM drive giving the technicians the ability to use many of the CD-ROM service support programs such as COSMOS (Service Manuals and Handbooks in PDF format on CD's) and RIBON (Spare Parts List on CDs).

Toshiba also recommends that technicians have access to the Internet to view the latest technical data and up-to-date problem resolutions posted on Toshiba's FYI website.

## **H. Warranty**

### **Warranty Policy**

All new Toshiba products purchased by a dealer are subject to a ninety (90) day limited warranty given by TABS (all used products are sold "as is"). The new product warranty, which runs to the end-user, is as follows:

### **Toshiba America Business Solutions, Inc. Limited Warranty**

Toshiba America Business Solutions, Inc. (TABS) warrants that this machine, upon delivery by TABS or an authorized TABS dealer to a retail customer, will be in new condition and free from defects in material and workmanship for 90 days after delivery. This warranty is void (a): if the machine is used under other than normal use and maintenance conditions, (b): if the maintenance as set forth in TABS's maintenance literature is not performed, (c): if the machine is modified or altered, unless the modification or alteration is expressly authorized by TABS, (d): if the machine is subject to abuse, neglect or accident, (e): if it is repaired by someone other than TABS or an authorized TABS dealer, (f): if the serial number of the machine is defaced or missing, (g): if the retail customer uses non-TABS supplies and such supplies cause abnormal service calls or are unacceptable for use with the machine or are defective.

The sole obligation of TABS or Toshiba Corporation under this warranty, or under any other legal obligation with respect to the machine, is the repair or replacement by TABS, or its authorized dealer, with new or remanufactured parts (at their option), of such defective or missing parts as are causing the malfunction. If TABS or one of its authorized dealers does not replace or repair such parts, the retail customer's sole remedy will be a refund of the selling price of such parts as are proven to be defective and which are returned to TABS or one of its authorized dealers within the warranty period.

Under no circumstances will the retail customer or any user or dealer or other person be entitled to any direct, special, indirect or consequential damages, for breach of contract, tort, or otherwise. Under no circumstances will any such person be entitled to any sum greater than the purchase price paid for the machine.

To obtain service under this warranty, the retail customer must bring the malfunction of the machine to the attention of TABS or one of its authorized dealers within the 90 day period. Failure to bring the malfunction to TABS's attention, or to the attention of an authorized TABS dealer, within the prescribed time, results in the customer not being entitled to warranty service.

THERE ARE NO OTHER WARRANTIES FROM EITHER TOSHIBA AMERICA BUSINESS SOLUTIONS, INC. OR TOSHIBA CORPORATION WHICH EXTEND BEYOND THE FACE OF THIS WARRANTY. ALL OTHER WARRANTIES EXPRESSED OR IMPLIED, INCLUDING THE WARRANTIES OF MERCHANTABILITY, FITNESS FOR A PARTICULAR PURPOSE, AND FITNESS FOR USE, ARE EXCLUDED.

No TABS dealer and no person other than an officer of TABS may extend this warranty, nor may they modify it in any respect. No modification or extension is effective unless it is in writing.

Neither dealer nor any other person may extend TABS' limited warranty or modify it in any respect. No modification or extension of TABS's limited warranty is effective unless it is in a writing and signed by TABS' Vice President, General Manager, Electronic Imaging Division.

TABS warrants to Dealer that each new Product will be free from defects in material and workmanship for a period of ninety (90) days after the delivery of the product to Dealer by TABS or until delivery by Dealer to an end-user, whichever occurs first. DEALER'S WARRANTY IS SUBJECT TO THE SAME LIMITATIONS AND EXCLUSIONS (INCLUDING THOSE EXCLUDING MERCHANTABILITY) AS THE END-USER'S LIMITED WARRANTY (SEE PARAGRAPH 12 ABOVE). Dealer shall notify TABS of any claimed defect in any Product or related goods within thirty (30) days of its occurrence, by the giving of a written report setting forth all pertinent details including a description of the defect and the time and place of occurrence.

If Dealer elects to give a warranty to an end-user greater than the TABS limited warranty, Dealer must make it clear to the end-user that that warranty is being given only by Dealer and not by TABS.

To make certain that end-users understand the warranty coverage they are receiving from TABS, a sticker or other writing containing the TABS limited warranty may be affixed by TABS to products. Dealer may not remove such a sticker or writing. Dealer shall make certain that the sticker or writing is on each Product in its showroom and on the product upon delivery and installation; if a sticker or writing is missing, it is the Dealer's responsibility to replace it with a new one. Dealer shall obtain from TABS and stock an adequate supply of stickers or warranty writings.

Dealer shall make certain that all end-users are aware of the terms of the TABS limited warranty and of the maintenance requirements of Products prior to the sale of the products to an end-user.

Dealer is responsible for performing whatever warranty service an end-user (which purchased from Dealer) deserves under the TABS limited warranty. TABS's sole responsibility to the Dealer is to supply to Dealer without charge such replacement parts as are necessary, in accordance with the procedures set forth in TABS's parts warranty policy, which TABS may establish from time to time. If requested by TABS in writing, Dealer shall also be obligated to perform warranty service for Authorized Products or other Products in the territory, sold or marketed by persons other than Dealer, for which Dealer will be compensated in accordance with TABS's standard warranty compensation schedules then in effect.

Replacement parts and related goods will carry only such warranty (which shall be subject to such limitations and exclusions) as TABS may announce in writing and change from time to time.

Dealer and TABS agree TABS reserves the right at any time to amend or modify its warranty policy for end-users or for Dealers, including any limitations or exclusions applicable thereto, provided that such is done in writing, signed by TABS's Vice President, General Manager, Electronic Imaging Division.

If Dealer does not follow TABS's warranty policy, Dealer shall be legally responsible for any damages or expenses that arise beyond those expressly owed by TABS under its warranty policy.