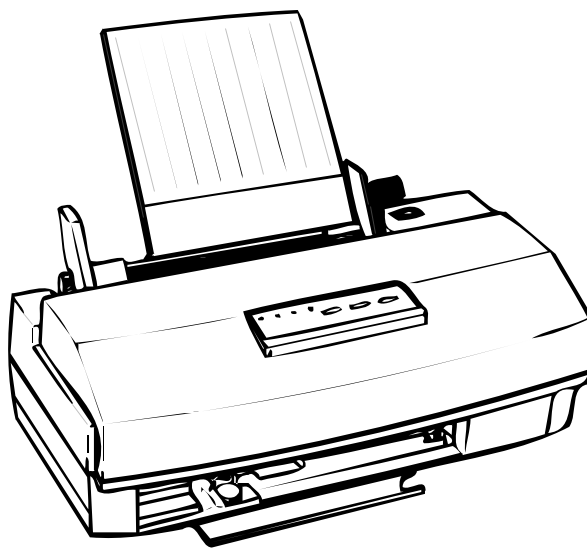


EPSON TERMINAL PRINTER  
*Stylus*<sup>™</sup> COLOR IIs & *Stylus*<sup>™</sup> 820

---

**SERVICE MANUAL**

---



**EPSON**

4005245

## **NOTICE**

All rights reserved. Reproduction of any part of this manual in any form whatsoever without SEIKO EPSON's express written permission is forbidden.

The contents of this manual are subjects to change without notice.

All efforts have been made to ensure the accuracy of the contents of this manual. However, should any errors be detected, SEIKO EPSON would greatly appreciate being informed of them.

The above notwithstanding SEIKO EPSON can assume no responsibility for any errors in this manual or the consequence thereof.

Epson and Epson's ESC/P are registered trademark of Seiko Epson Corporation.

General Notice: Other product names used herein are for identification purpose only and may be trademark of their respective companies.

**+ Copyright 1995 by SEIKO EPSON CORPORATION Nagano, Japan**

# PRECAUTIONS

Precautionary notations throughout the text are categorized relative to 1) personal injury and 2) damage to equipment.

**DANGER** Signals a precaution which, if ignored, could result in serious or fatal personal injury. Great caution should be exercised in performing procedures preceded by DANGER Headings.

**WARNING** Signals a precaution which, if ignored, could result in damage to equipment.

The precautionary measures itemized below should always be observed when performing repair/maintenance procedures.

## DANGER

1. ALWAYS DISCONNECT THE PRODUCT FROM THE POWER SOURCE AND PERIPHERAL DEVICES PERFORMING ANY MAINTENANCE OR REPAIR PROCEDURE.
2. NOWORK SHOULD BE PERFORMED ON THE UNIT BY PERSONS UNFAMILIAR WITH BASIC SAFETY MEASURES AS DICTATED FOR ALL ELECTRONICS TECHNICIANS IN THEIR LINE OF WORK.
3. WHEN PERFORMING TESTING AS DCTATED WITHIN THIS MANUAL, DO NOT CONNECT THE UNIT TO A POWER SOURCE UNTIL INSTRUCTED TO DO SO. WHEN THE POWER SUPPLY CABLE MUST BE CONNECTED, USE EXTREME CAUTION IN WORKING ON POWER SUPPLY AND OTHER ELECTRONIC COMPONENTS.

## WARNING

1. REPAIRS ON EPSON PRODUCT SHOULD BE PERFORMED ONLY BY AN EPSON CERTIFIED REPAIR TECHNICIAN.
2. MAKE CERTAIN THATTHE SOURCE VOLTAGES IS THE SAME AS THE RATED VOLTAGE, LISTED ON THE SERIAL NUMBER/RATING PLATE. IF THE EPSON PRODUCT HAS A PRIMARY AC RATING DIFFERENT FROM AVAILABLE POWER SOURCE, DO NOT CONNECT IT TO THE POWER SOURCE.
3. ALWAYS VERIFY THAT THE EPSON PRODUCT HAS BEEN DISCONNECTED FROM THE POWER SOURCE BEFORE REMOVING OR REPLACING PRINTED CIRCUIT BOARDS AND/OR INDIVIDUAL CHIPS.
4. IN ORDER TO PROTECT SENSITIVE MICROPROCESSORS AND CIRCUITRY, USE STATIC DISCHARGE EQUIPMENT,SUCH AS ANTI-STATIC WRIST STRAPS, WHEN ACCESSING INTERNALCOMPONENTS.
5. REPLACE MALFUNCTIONING COMPONENTS ONLY WITH THOSE COMPONENTS BY THE MANUFACTURE; INTRODUCTION OF SECOND-SOURCE ICs OR OTHER NONAPPROVED COMPONENTS MAY DAMAGE THE PRODUCT AND VOID ANY APPLICABLE EPSON WARRANTY.

## **PREFACE**

This manual describes functions, theory of electrical and mechanical operations, maintenance, and repair of Stylus Color IIs / Stylus 820.

The instructions and procedures included herein are intended for the experience repair technician, and attention should be given to the precautions on the preceding page. The chapters are organized as follows:

### **CHAPTER 1. PRODUCT DESCRIPTION**

Provides a general product overview, lists specifications, and illustrates the main components of the printer.

### **CHAPTER 2. OPERATING PRINCIPLES**

Describes the theory of printer operation.

### **CHAPTER 3. DISASSEMBLY AND ASSEMBLY**

Includes the step-by-step guide for product disassembly and assembly

### **CHAPTER 4. ADJUSTMENTS**

Includes a step-by-step guide for adjustment.

### **CHAPTER 5. TROUBLESHOOTING**

Provides Epson-approved techniques for adjustment.

### **CHAPTER 6. MAINTENANCE**

Describes preventive maintenance techniques and lists lubricants and adhesives required to service the equipment.

### **APPENDIX**

Describes connector pin assignments, circuit diagrams, circuit board component layout and exploded diagram.

**The contents of this manual are subject to change without notice.**

**REVISION SHEET**

<b>Revision</b>	<b>Issue Date</b>	<b>Contents</b>
Rev.-A	August 25,1995	1st issue

## TABLE OF CONTENTS

<b>CHAPTER 1.</b>	<b>PRODUCT DESCRIPTION</b>
<b>CHAPTER 2.</b>	<b>OPERATION PRINCIPLES</b>
CHAPTER 3	DISASSEMBLY AND ASSEMBLY
CHAPTER 4.	ADJUSTMENT
<b>CHAPTER 5.</b>	<b>TROUBLESHOOTING</b>
<b>CHAPTER 6.</b>	<b>MAINTENANCE</b>
<b>APPENDIX</b>	

# Chapter 1 Operating Principles

---

## Table of Contents

<b>1.1 OVERVIEW</b>	<b>1-1</b>
<hr/>	
<b>1.2 SPECIFICATIONS</b>	<b>1-1</b>
1.2.1 Printing Specifications	1-2
1.2.2 Paper Handling Specifications	1-4
1.2.3 Paper Specifications	1-4
1.2.4 Ink Cartridge Specifications	1-6
1.2.5 Electrical Specifications	1-7
1.2.6 Environmental Specifications	1-7
1.2.7 Reliability	1-8
1.2.8 Safety Approvals	1-8
1.2.9 Acoustic Noise	1-8
1.2.10 Physical Specifications	1-8
<hr/>	
<b>1.3 INTERFACE SPECIFICATIONS</b>	<b>1-9</b>
1.3.1 Parallel Interface Specifications	1-9
<hr/>	
<b>1.4 OPERATION CONTROLS</b>	<b>1-11</b>
1.4.1 Control Panel	1-11
1.4.2 Panel Operation and Built-in Function	1-11
1.4.3 Default Settings	1-14
1.4.3.1 Setting Method	1-14
1.4.3.2 Setting Menu	1-15
1.4.4 Error Conditions	1-18
1.4.5 Printer Initialization	1-18
1.4.5.1 Hardware Initialization	1-18
1.4.5.2 Software Initialization	1-18
1.4.5.3 Panel Initialization	1-18
<hr/>	
<b>1.5 MAIN COMPONENTS</b>	<b>1-19</b>
1.5.1 Main Control Board(C160 Main Control Board)	1-19
1.5.2 Power Supply Board(C160 PSB/PSE Board)	1-20
1.5.3 C160 I/F Board	1-20
1.5.4 Printer Mechanism((M-4C10)	1-21
1.5.5 Housing	1-21

## List of Figures

Figure 1-1. Exterior View of the Stylus Color IIs(820) .....	1-1
Figure 1-2. Nozzle Configuration .....	1-2
Figure 1-3. Printable Area .....	1-4
Figure 1-4. Paper Select Lever .....	1-5
Figure 1-5. Temperature / Humidity Range .....	1-7
Figure 1-6. Data Transmission Timing .....	1-9
Figure 1-7. Control Panel Appearance .....	1-11
Figure 1-8. C160 Main Control Board Component Layout .....	1-19
Figure 1-9. C160 PSB/PSE Board Component Layout .....	1-20
Figure 1-10. C160 I/F Board Component Layout .....	1-20
Figure 1-11. M-4C10 Printer Mechanism .....	1-21
Figure 1-12. Housing .....	1-21

## List of Tables

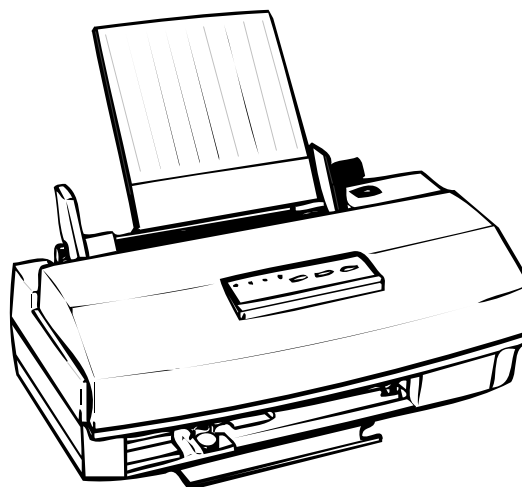
Table 1-1. Print Speed and Printable Column .....	1-2
Table 1-2. Character Tables .....	1-3
Table 1-3. Paper Specifications .....	1-4
Table 1-4. Adjust Lever Settings .....	1-5
Table 1-5. Paper Select Lever Settings .....	1-5
Table 1-6. Black I/C Specifications .....	1-6
Table 1-7. Color I/C Specifications .....	1-6
Table 1-8. Rated Electrical Ranges .....	1-7
Table 1-9. Acceptable Environmental Conditions .....	1-7
Table 1-10. Signal and Connector Pin Assignment for Parallel I/F .....	1-10
Table 1-11. Panel Operation .....	1-11
Table 1-12. Built-in Functions on the Panel .....	1-12
Table 1-13. Button Operations in Default Setting Mode .....	1-12
Table 1-14. Error Indicators .....	1-13
Table 1-15. Default Setting Items .....	1-14
Table 1-16. Language Selections .....	1-15
Table 1-17. Feature Selections .....	1-16
Table 1-18. Character Table Selection .....	1-17

## 1.1 FEATURES

The Stylus Color IIs printer is a color ink jet dot matrix printer that comes with a 64-nozzle black printhead and a 60-nozzle CMY color printhead, either of which can be installed in the printer. The Stylus 820 version of the same printer comes standard with only the 64-nozzle black printhead; however, the CMY color printhead can be purchased as an optional upgrade. Whenever this manual mentions the Stylus Color IIs, its descriptions are equally applicable to the Stylus 820. The major printer features are:

- ❑ High-quality color print
    - 720 dpi printing
    - 720 dpi printing on plain paper
    - 720, 360 dpi printing on special coated paper  
(Use the monochrome head only with plain paper)
  - ❑ High-speed print
    - LQ 125 cps (monochrome head)
    - LQ 170 cps (CMY head, using one-pass printing)
- Note: The CMY head prints 360 dpi printing in three passes.
- ❑ Built-in auto sheet feeder
    - Plain paper (Can be installed up to the hopper guide marker.)
    - Transparency film (Can be installed up to the hopper guide marker.)
    - Glossy paper (1-sheet only)
    - Coated paper (Can be installed up to the hopper guide marker.)
    - Envelopes (30 sheets)
    - Postcards (30 sheets)
  - ❑ Built-in I/F
    - Parallel I/F only (8-bit parallel: IEEE P1284 mode)
  - ❑ Easy setup
    - No DIP switches
  - ❑ 3 scalable fonts and 3 LQ fonts standard
    - Roman T, Sans Serif H, Roman, Sans Serif (scalable)
    - Roman, Sans Serif, Courier, Prestige, Script (LQ, bitmap)
  - ❑ Character tables
    - 9 character tables (standard version)
    - 15 character tables (NLSP version)
  - ❑ Low running cost

The figure below shows the Stylus Color IIs.



**Figure 1-1. Exterior Viewing of Stylus Color IIs(820)**

## 1.2 SPECIFICATIONS

This section provides statistics and other detailed information for the printer.

### 1.2.1 Printing Specifications

Print system: On-demand ink jet system  
 Nozzle configuration: 64 nozzles (10 × 2 + 11 × 4 standard ): monochrome  
 60 nozzles (20 × 3 standard): color

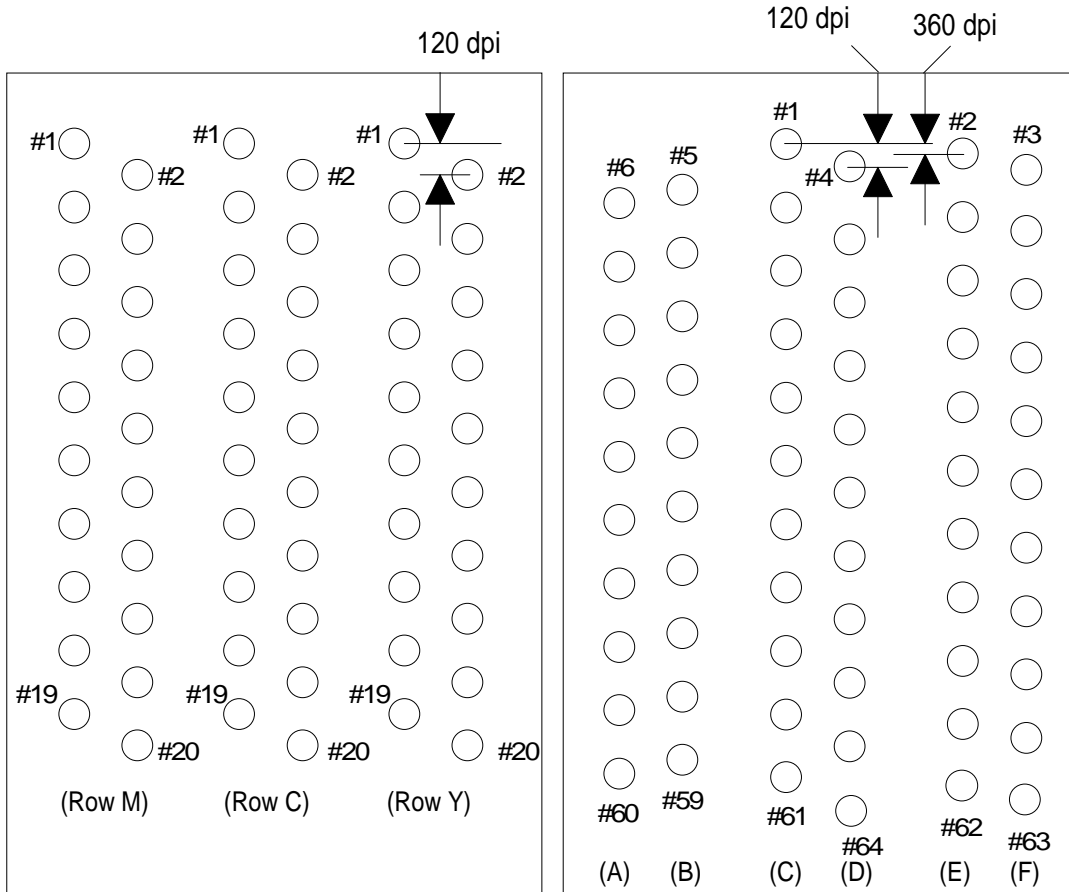


Figure 1-2. Nozzle Configuration

Printing direction: Bidirectional with logic-seeking

Table 1-1. Print Speed and Printable Columns

Character Pitch	Printable Columns	Printing Speed (cps)	
		Monochrome	CMY
10 cpi (Pica)	80	125	170
12 cpi (Elite)	96	150	204
15 cpi	120	188	255
17 cpi (Pica condensed)	136	214	290
20 cpi (Elite condensed)	160	250	340

Character tables: Legal and 14 international sets

**Table 1-2. Character Tables**

Character Tables		Bitmap Fonts	Scalable Fonts	
		EPSON Roman EPSON Sans Serif EPSON Courier	EPSON Roman EPSON Sans Serif	EPSON Roman T EPSON Sans Serif H
<b>Standard</b>	Italic	Supported	Supported	Supported
	PC437 (U.S./Standard Europe)			
	PC850 (Multilingual)			
	PC860 (Portuguese)			
	PC861 (Icelandic)			
	PC863 (Canadian-French)			
	PC865 (Nordic)			
	Abicomp			
BRASCII				
<b>NLSP</b>	Italic	Supported	Supported	Supported
	PC437 (U.S./Standard Europe)			
	PC850 (Multilingual)			
	PC437 (Greek)	Supported	Supported	Not supported
	PC852 (East Europe)			
	PC853 (Turkish)			
	PC855 (Cyrillic)			
	PC857 (Turkish)			
	PC866 (Russian)			
	PC869 (Greek)			
	MAZOWIA (Poland)			
	Code MJK (Czecho/Slovakia)			
	ISO 8859-7 (Latin/Greek)			
	ISO Latin 1T (Turkish)			
Bulgaria (Bulgaria)				

Fonts:

*Bitmap LQ fonts*

- EPSON Roman (10 cpi/12 cpi/15 cpi/Proportional)
- EPSON Sans Serif (10/12/15/Proportional)
- EPSON Courier (10/12/15)

*Scalable fonts*

- EPSON Roman 10.5 points, 8 ~ 32 points (in units of 2 points)
- EPSON Sans Serif 10.5 points, 8 ~ 32 points (in units of 2 points)
- EPSON Roman T 10.5 points, 8 ~ 32 points (in units of 2 points)
- EPSON Sans Serif H 10.5 points, 8 ~ 32 points (in units of 2 points)

Control codes: ESC/P 2 and expanded raster graphics codes

Input data buffer: 0.5KB or 64KB

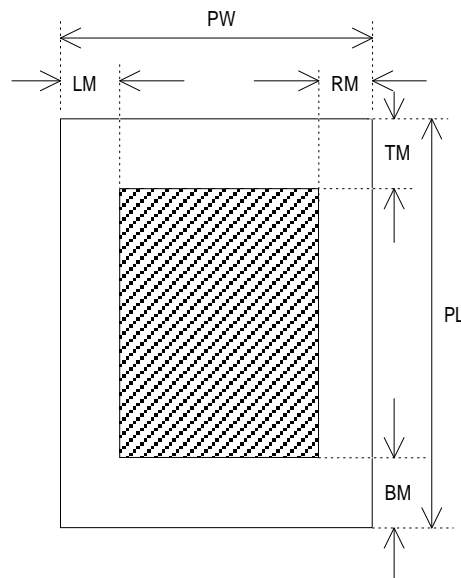
### 1.2.2 Paper Handling Specifications

Feeding method: Friction feed paper is fed from the built-in auto sheet feeder (ASF).  
 Line spacing: 1/6 inch feed or programmable in 1/360 inch minimum increments.  
 Paper path: Cut sheets are fed from the built-in auto sheet feeder (ASF).  
 Top in and front out.  
 Feeding speed: 102 msec. (at 1/6-inch feed pitch).

### 1.2.3 Paper Specifications

**Table 1-3. Paper Specifications**

		Cut Sheets			Envelopes	
		Transparencies			No. 10	DL
		A4	Letter	Legal		
<b>PW</b>	Width	210 mm	216 mm	216 mm	240 mm	220 mm
<b>PL</b>	Length	297 mm	279 mm	358 mm	104 mm	110 mm
<b>LM</b>	Left margin	3 mm or more	3 mm or more	3 mm or more	3 mm or more	3 mm or more
<b>RM</b>	Right margin	3 mm or more	3 mm or more	3 mm or more	3 mm or more	3 mm or more
<b>TM</b>	Top margin	3 mm or more	3 mm or more	3 mm or more	3 mm or more	3 mm or more
<b>BM</b>	Bottom margin	14 mm or more	14 mm or more	14 mm or more	14 mm or more	14 mm or more



**Figure 1-3. Printable Area**

The adjust lever on the upper case must be set to the proper position for the paper thickness, as shown in Table 1-4.

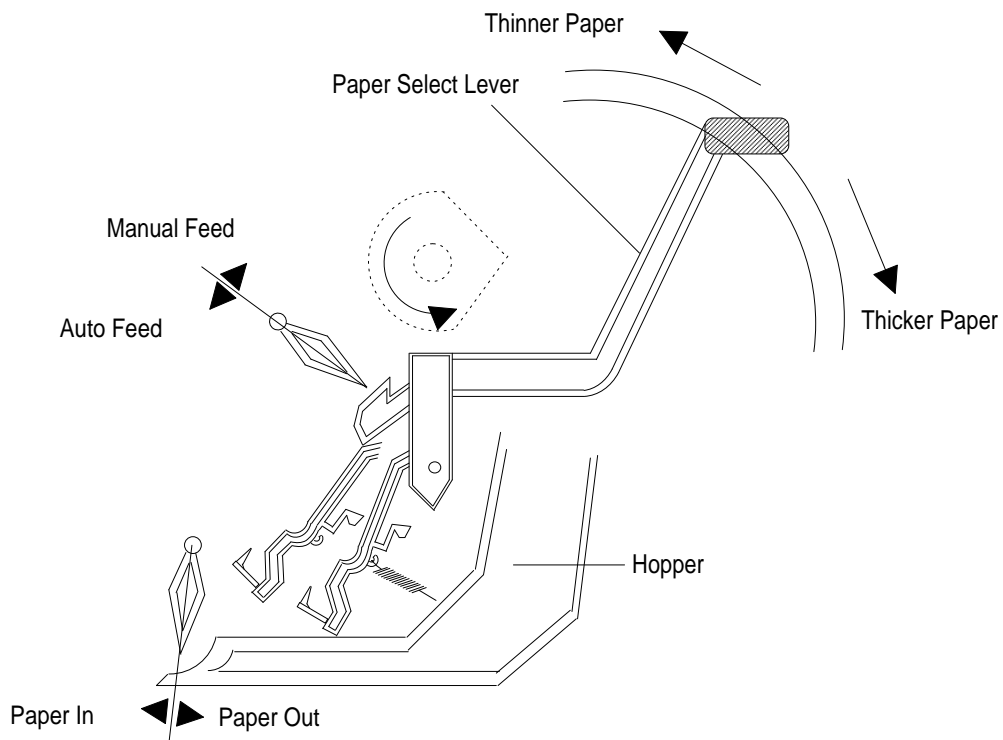
**Table 1-4. Adjust Lever Settings**

Lever Position	Paper	Paper Thickness
Front (0 position)	Normal position	0 mm
Rear (+ position)		0.62 mm

Also the paper select lever on the upper case must be set to the proper position for the paper varieties shown in Table 1-5.

**Table 1-5. Paper Select Lever Settings**

		Specifications for the Medium	
PF Mode	Lever Position	Cut Sheets	Envelopes Postcards
	ASF Feed		
	Thinner paper (Front)	OK	NO
Manual Feed	Thick paper (Rear)	OK	OK
	Thinner paper (Front)	NO	NO



**Figure 1-4. Paper Select Lever**

*Note:* “OK” means paper can be used and “NO” means paper cannot.

## 1.2.4 Ink Cartridge Specifications

**Table 1-6. Black I/C Specifications**

Item	Specifications
Type	Exclusive cartridge
Color and Weight	Approximately 54 g (internal ink weight is 36 g $\pm$ 0.5 g)
Ink Life	High-quality ink produces 800 thousand characters
Validity	2 years (sealed in package) / 6 months (out of package)
Storage Temperature	<input type="checkbox"/> -30 to 40° C (-22 ~ 104° F) (Storage: a month or less at 40° C (104° F)) <input type="checkbox"/> -20 to 40° C (-15 ~ 104° F) (Transit: a month or less at 40° C (104° F)) <input type="checkbox"/> -30 to 60° C (-22 ~ 140° F) (Transit: 120 hours or less at 60° C (140° F))
Dimensions	30.0 (W) $\times$ 58.0 (D) $\times$ 38.5 $\pm$ 0.3 (H) mm

**Table 1-7. Color I/C Specifications**

Item	Specifications
Type	Exclusive cartridge
Color and Weight	Approximately 70 g (internal ink weight is 12.8 g $\pm$ 0.5 g)
Ink Life	100% solid pattern: A4 — 16 sheets / each color
Validity	2 years (sealed in package) / 6 months (out of package)
Storage Temperature	<input type="checkbox"/> -30 to 40° C (-22 ~ 104° F) (Storage: a month or less at 40° C (104° F)) <input type="checkbox"/> -20 to 40° C (-15 ~ 104° F) (Transit: a month or less at 40° C (104° F)) <input type="checkbox"/> -30 to 60° C (-22 ~ 140° F) (Transit: 120 hours or less at 60° C (140° F))
Dimensions	42.9 (W) $\times$ 56.5 (D) $\times$ 38.5 $\pm$ 0.3 (H) mm

1.2.5 Electrical Specifications

Table 1-8. Rated Electrical Ranges

Specification	120 V Version	220 - 240 V Version
Rated voltage	120 VAC	220 - 240 VAC
Input voltage range	103.5 ~ 132 V	198 ~ 264 V
Rated frequency range	50 ~ 60 Hz	50 ~ 60 Hz
Input frequency range	49.5 ~ 60.5 Hz	49.5 ~ 60.5 Hz
Rated current	0.5 A	0.3 A
Power consumption	Approx. 13 W (self-test with 10-cpi LQ characters)	Approx. 13 W (self-test with 10-cpi LQ characters)
Insulation resistance	10 MΩ, minimum (applying 500 VDC between AC line and chassis)	10 MΩ, minimum (applying 500 VDC between AC line and chassis)
Dielectric strength	1000 VAC rms for 1 minute or 1200 VAC rms for 1 second (between AC line and chassis)	1500 VAC rms for 1 minute (between AC line and chassis)

1.2.6 Environmental Conditions

Table 1-9. Acceptable Environmental Conditions

Condition	Operating	Non Operating
Temperature	10 ~ 35° C (50 ~ 95° F) <sup>*1</sup>	-20 ~ 60° C (-4 ~ 122° F) <sup>*2</sup>
Humidity	20 ~ 80% RH <sup>*1, 3</sup>	5 ~ 85% RH <sup>*2, 3</sup>
Shock resistance	1G (within 1 msec.)	2G (within 2 msec.) <sup>*2</sup>
Vibration resistance	0.15 G	0.50 G <sup>*2</sup>

<sup>\*1</sup> : For printer operation, conditions must be in the range shown in the figure below.

<sup>\*2</sup> : These conditions are applicable when the printer is in its shipping container.

<sup>\*3</sup> : Without condensation.

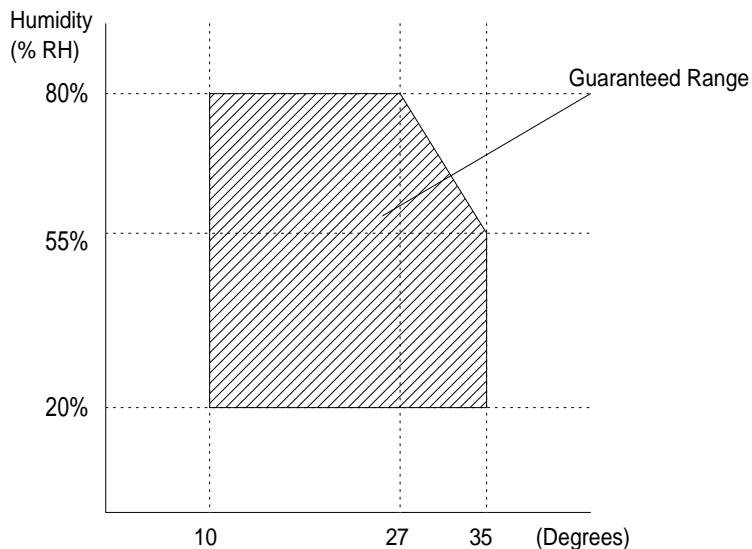


Figure 1-5. Temperature / Humidity Range

### 1.2.7 Reliability

Total print volume:	25,000 pages (A4, letter)
Printhead life:	500 million dots/nozzle (color and monochrome)

### 1.2.8 Safety Approvals

Safety standards:	120 V version:	UL1950 with D3, CSA C22.2 # 950 with D3
	220-240 V version:	EN 60950 (TÜV, SEMKO, DEMKO, NEMKO, SETI)
Radio frequency interference (RFI):	120 V version:	FCC Part 15 Subpart B Class B
	220-240 V version:	Vfg.243 (VDE0878 part 3, part 30) EN55022 (CISPR PUB. 22) class B CSA C108.8

### 1.2.9 Acoustic Noise

Level:	Approximately 45 dB (A) (Per ISO 7779)
--------	--

### 1.2.10 Physical Specifications

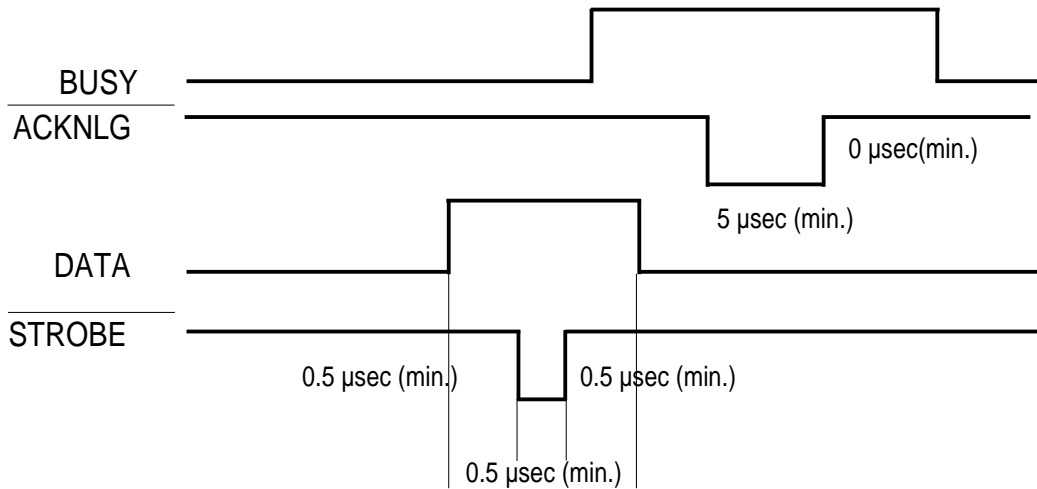
Dimensions (W × D × H):	396.7 mm (W) × 205.6 mm (D) × 144.0 mm (H)
Weight:	About 3.9 kg (8.6 lb.), excluding head and ink cartridge

## 1.3 INTERFACE SPECIFICATIONS

The Stylus Color IIs is standard-equipped with an 8-bit parallel and serial interface.

### 1.3.1 Parallel Interface Specifications

Data format:	8-bit parallel
Synchronization:	By <u>STROBE</u> pulse synchronization
Handshaking:	By <u>BUSY</u> and <u>ACKNLG</u> signals
Signal level:	TTL compatible level
Adaptable connector:	36-pin 57-30360 (Amphenol) or equivalent



**Figure 1-6. Data Transmission Timing**

Data transmission timing: See Figure 1-6.

**Note:** Transition time (rise time and fall time) of every input signal must be less than 0.2 μs.

The Busy signal is active (HIGH) under the following conditions:

- During data reception (See Figure 1-6.)
- When the input buffer is full
- When the INIT input signal is active
- During initialization
- When the ERROR or PE signal is active
- During the self-test mode
- During the demonstration mode
- During the default setting mode
- When a fatal error occurs

The ERROR signal is active (LOW) under the following conditions:

- When a paper-out error occurs
- When a no ink cartridge error occurs
- When a fatal error occurs

The PE signal is active (HIGH) under the following conditions:

- When a paper-out error occurs
- When a fatal error occurs

Table 1-10 shows the connector pin assignments and signal functions of the 8-bit parallel interface.

**Table 1-10. Signal and Connector Pin Assignments for Parallel Interface**

Pin No.	Signal Name	I/O*	Description
1	$\overline{\text{STROBE}}$	I	The $\overline{\text{STROBE}}$ pulse is used to read data from the host computer. The pulse width must be 0.5 $\mu\text{s}$ or more. Normally, it is HIGH, and data is latched with the rising edge of this signal.
2-9	DATA 1-8	I	DATA 1-8 are parallel data bits. When one of these signals is HIGH, the data bit is 1; when LOW, the data bit is 0. The most significant bit (MSB) is DATA 8. The signal state must be maintained for 0.5 $\mu\text{s}$ on either side of the $\overline{\text{STROBE}}$ signal's active edge.
10	$\overline{\text{ACKNLG}}$	O	$\overline{\text{ACKNLG}}$ is an acknowledge pulse with a width of approximately 10 $\mu\text{s}$ . This signal goes LOW upon the completion of data reception to indicate that the printer is ready to receive further data.
11	BUSY	O	The BUSY signal informs the host computer of the printer's status. When this signal is HIGH, the printer cannot accept any more data.
12	PE	O	This signal indicates whether paper is available in the printer or not. A HIGH level indicates no paper.
13	SLCT	O	Pulled up to +5 V through a 1.0 K $\Omega$ resistor in the printer.
14	$\overline{\text{AFXT}}$	I	If this signal is set to LOW, the printer automatically performs one line feed upon receipt of a CR (carriage return) code. The status of this signal is checked only at power on and initialization.
31	$\overline{\text{INIT}}$	I	If this signal goes LOW, the printer is initialized. The pulse width of this signal must be 50 $\mu\text{s}$ or more.
32	$\overline{\text{ERROR}}$	O	This signal goes LOW if the printer has a fatal error or runs out of paper.
35	+5 V	—	Pulled up to +5 V through 1.0 K $\Omega$ resistor in the printer.
17	CHASSIS	—	Chassis ground.
16	GND	—	Signal ground.
19-30	—	—	—
33,36	—	—	Not used.
15,18,34	—	—	—

\* The I/O column indicates the direction of the signal as viewed from the printer.

## 1.4 OPERATIONS

This section describes the basic operations of the printer.

### 1.4.1 Control Panel

The control panel for this printer has 3 non-lock-type push buttons, and 5 LED indicators for easy operation of the various printer functions.

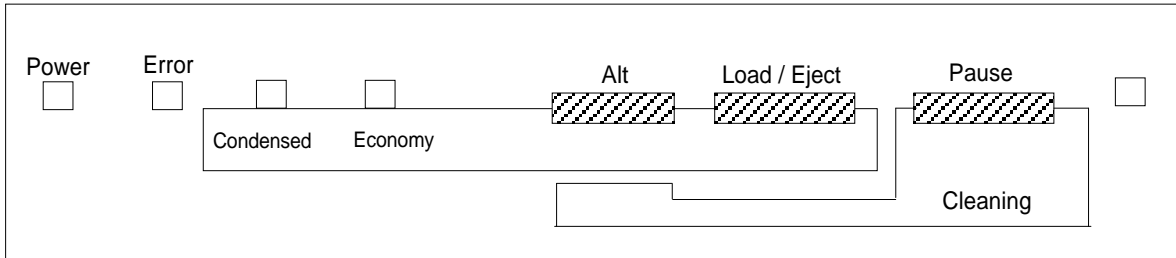


Figure 1-7. Control Panel Appearance

### 1.4.2 Panel Operation and Built-in Function

You can activate the following modes by doing the procedure in table 1-11 and 1-12.

Table 1-11. Panel Operation

Button	Operations		+
^	Single Button Operations		Combined with Alt Button
^	Pressed and released	Held down 3 seconds	Pressed and released
Alt	No function	I/C or head unit replacement	_____
Load/Eject	Load/Eject	No function	Economy/Condensed
Pause	Pause	Reset	Cleaning

**Table 1-12. Built-in Functions on the Panel**

<i>Button</i>	<b>Function</b>
<i>Alt</i>	Demonstration printing
<i>Load/Eject</i>	Self-test
<i>Pause</i>	Default setting mode (with printing)
<i>Alt + Load/Eject</i>	Non-smear printing
<i>Load/Eject + Pause</i>	Data dump mode (Hex mode)
<i>Pause + Alt</i>	Default setting mode (without printing)
<i>Pause + Load/Eject + Pause</i>	Reset to the default settings
<i>Other combinations</i>	Not available

**Table 1-13. Button Operations in Default Setting Mode**

<i>Button</i>	<b>Function</b>
<i>Alt</i>	Move to the next item or menu
<i>Pause</i>	Set item

**Indicators**

<b>Power</b>	<i>On when printer is on. Blinks during power on and off.</i>
<b>Error</b>	<i>On when printer encounters an error, such as ink end, paper out, paper jam, etc.</i>
<b>Condensed</b>	<i>On when printer is in the condensed mode (50% or 80%).</i>
<b>Economy</b>	<i>On when printer is in the economy mode.</i>
<b>Pause</b>	<i>On when printer is paused.</i>
<b>LED combinations</b>	<i>See Table 1-14.</i>

**Table 1-14. Error Indications**

<i>Printer Status</i>	<b>Indicators</b>					+
^	Power	<b>Error</b>	<b>Condensed</b>	<b>Economy</b>	<b>Pause</b>	
<i>Pause</i>	On	—	—	—	On	
<i>Economy</i>	On	—	—	On	—	
<i>Condensed</i>	On	On	On	—	—	
<i>Panel reset accepted</i>	On	Blinks	On	On	On	
<i>Ink low (printable)</i>	On	Blinks (rapidly)	—	—	—	
<i>Ink out (unprintable)</i>	On	On	—	—	On	
<i>Paper out</i>	On	Off	—	—	On	
<i>Paper jam</i>	On	Off	—	Blink	On	
<i>Head, I/C replacement</i>	On	Blinks	—	—	Blinks	
<i>Head, I/C not installed (in replacement mode)</i>	On	Blinks	—	—	Blinks	
<i>Head, I/C not installed</i>	On	Blinks	Off	Off	Blinks	
<i>Carriage control error</i>	On	Blinks	Blinks	Off	Blinks	
<i>Maintenance request</i>	On	Blinks	Blinks	Blinks	Blinks	

### 1.4.3 Default Settings

The printer can save some printer setting parameters that define its functions at initialization. You can change these parameters using the printer's default setting mode.

#### 1.4.3.1 Default Setting Items

You can use default setting mode to change settings listed in the table below. Activate default-setting mode by holding down the Pause or the Pause and Alt buttons (for default setting mode without printing) while turning on the printer.

**Table 1-15. Default Setting Items**

Item	Selections		+
<i>Character Tables</i>	Standard Version		+
^	Italic USA Italic France Italic Germany Italic UK	Italic Italy Italic Spain <b><u>PC437</u></b> <b><u>PC850</u></b>	PC865 PC861 BRASCII Abicomp
^	Italic Denmark	<b><u>PC860</u></b>	^
^	Italic Sweden	<b><u>PC863</u></b>	^
^	NLSP Version		+
^	Italic USA Italic France Italic Germany Italic UK Italic Denmark Italic Sweden Italic Italy Italic Spain	<b><u>PC437</u></b> <b><u>PC850</u></b> <b><u>PC853</u></b> <b><u>PC857</u></b> <b><u>PC437 Greek</u></b> <b><u>PC855</u></b> <b><u>PC866</u></b> <b><u>PC852</u></b>	PC869 ISO 8859-7 ISO Latin 1T MAZOWIA Code MJK Bulgaria
<i>Typestyles</i>	Roman Sans Serif <b><u>Courier</u></b> <b><u>Roman T (PS)</u></b> <b><u>Sans Serif H (PS)</u></b>		+
<i>Character Pitches</i>	<b><u>10 CPI (10 CPI, Condensed off)</u></b> <b><u>12 CPI (12 CPI, Condensed off)</u></b> <b><u>15 CPI (15 CPI, Condensed off)</u></b> <b><u>17.1 CPI (10 CPI, Condensed on)</u></b> <b><u>20 CP I(12 CPI, Condensed on)</u></b> <b><u>Proportional (PS, Condensed off)</u></b>		+
<i>Print Direction</i>	<b><u>Auto</u></b> <b><u>Bidirectional</u></b> <b><u>Uni-directional</u></b>		+
<i>Network I/F Mode</i>	<b><u>Off (Usual environment)</u></b> <b><u>On (Network environment)</u></b>		+

**Table 1-15. Default Setting Items (Continued)**

<i>Item</i>	<b>Contents</b>
<i>Auto line feed</i>	<u>Off</u> On
<i>Loading position</i>	<u>8.5 mm</u> 3 mm
<i>Thick paper</i>	<u>Envelopes</u> Index card (portrait)

**Note:** The underlined value is the factory setting.

### 1.4.3.2 Changing the Default Settings

To change the printer's default settings:

1. Hold down the Pause button and turn on the printer. The printer outputs a sheet that shows the firmware version and describes how to select the language used to print messages. You can select a language by pressing the Alt button, and set it by pressing the Pause button. (See Table 1-16.)

**Table 1-16. Language Selection**

	<b>Error LED</b>	<b>Condensed LED</b>	<b>Economy LED</b>
<i>English</i>	<b>On</b>	Off	Off
<i>Francias</i>	<b>Off</b>	On	Off
<i>Deutsch</i>	<b>On</b>	On	Off
<i>Italiano</i>	<b>Off</b>	Off	On
<i>Español</i>	<b>On</b>	Off	On

2. Press the Pause button. The printer prints the current settings using the selected language. It also prints a table showing how to change printer settings.
3. Press the Alt button to advance through the setting menus. The current printer settings are indicated by the Error, Condensed, and Economy LEDs. Each time you press the Pause button, you advance to the next setting, and the three font LEDs change according to the selection.
4. After you set all values, turn the printer off to save the new settings.

Table 1-17. Feature Selections

<i>Menu</i>				<i>Setting Value</i>			<b>+</b>
<i>Feature/ Menu</i>	<b>Error LED</b>	<b>Condensed LED</b>	<b>Economy LED</b>	<b>Setting</b>	<b>Error LED</b>	<b>Condensed LED</b>	<b>Economy LED</b>
<i>Character Table</i>	On	Off	Off	See Table 1-18.			<b>+</b>
<i>Print Direction</i>	Off	On	Off	Auto	Blinks	Off	Off
^				Bi-D	Blinks	On	Off
^				Uni-D	Blinks	Off	On
<i>Network I/F Mode</i>	On	On	Off	Off	Blinks	Off	Off
^				On	Blinks	On	Off
<i>Auto Line Feed</i>	Off	Off	On	Off	Blinks	Off	Off
^				On	Blinks	On	Off
<i>Loading Position</i>	On	Off	On	3 mm	Blinks	Off	Off
^				8.5 mm	Blinks	On	Off
<i>Font</i>	Off	On	On	Roman	Blinks	Off	Off
^				Sans serif	Blinks	On	Off
^				Courier	Blinks	Off	On
^				Roman T	Blinks	On	On
^				Sans serif H	Off	Blinks	Off
<i>Pitch</i>	On	On	On	10 CPI	Blinks	Off	Off
^				12 CPI	Blinks	On	Off
^				15 CPI	Blinks	Off	On
^				17.1 CPI	Blinks	On	On
^				20 CPI	Off	Blinks	Off
^				Proportional	On	Blinks	Off
<i>Thick Paper</i>	Off	Off	Off	Envelopes	Blinks	Off	Off
^				Index cards	Blinks	On	Off

**Table 1-18. Character Table Selection**

<i>Version</i>	<b>Settings</b>	<i>Error LED</i>	<i>Condensed LED</i>	<i>Economy LED</i>
<i>Common</i>	Italic U.S.A.	Blinks	Off	Off
^	Italic France	Blinks	On	Off
^	Italic Germany	Blinks	Off	On
^	Italic U.K.	Blinks	On	On
^	Italic Denmark 1	Off	Blinks	Off
^	Italic Sweden	On	Blinks	Off
^	Italic Italy	Off	Blinks	On
^	Italic Spain 1	On	Blinks	On
^	PC437	Off	Off	Blinks
^	PC850	On	Off	Blinks
<i>Standard</i>	PC860	Off	On	Blinks
^	PC863	On	On	Blinks
^	PC865	Blinks	Blinks	Off
^	PC861	Blinks	Blinks	On
^	BRASCII	Off	Blinks	Blinks
^	Abicomp	On	Blinks	Blinks
<i>NLSP</i>	PC437 Greek	Blinks	Blinks	Off
^	PC853	Off	On	Blinks
^	PC855	Blinks	Blinks	Off
^	PC852	On	Blinks	Blinks
^	PC857	On	On	Blinks
^	PC866	Off	Blinks	Blinks
^	PC869	Blinks	Off	Blinks
^	MAZOWIA	Off	On	On
^	Code MJK	On	On	On
^	ISO 8859-7	Blinks	On	Blinks
^	ISO Latin 1T	Blinks	Blinks	Blinks
^	Bulgaria	Off	Off	Off

### 1.4.4 Error Conditions

The printer can detect various errors and indicate them with LEDs. Refer to Table 1-14.

### 1.4.5 Printer Initialization

There are three initialization methods: hardware initialization, software initialization, and panel initialization.

#### 1.4.5.1 Hardware Initialization

Hardware initialization is performed by:

- Turning on the printer.
- Sending the parallel interface the  $\overline{\text{INIT}}$  signal.

(If the  $\overline{\text{INIT}}$  signal is active when the printer is turned on, hardware initialization is started when the  $\overline{\text{INIT}}$  signal becomes inactive.)

When hardware initialization is performed:

- The printer mechanism is initialized.
- Input data buffer is cleared.
- Downloaded character definitions are cleared.
- Print buffer is cleared.
- Default values are set.

#### 1.4.5.2 Software Initialization

Software initialization is performed upon receipt of the control code ESC @.

When software initialization is performed:

- The print buffer is cleared.
- Default values are set.

#### 1.4.5.3 Panel Initialization

Panel initialization is performed by holding down the Alt button for 3 seconds.

When the panel initialization is performed:

- The input data buffer is cleared.
- The print buffer is cleared.
- Default values are set.

## 1.5 MAIN COMPONENTS

The main components of the Stylus Color IIs are:

- ❑ Printer mechanism (M-4C10)
- ❑ Main control board (C160 MAIN Board)
- ❑ Power supply unit (C160 PSB/PSE Board)
- ❑ Control panel board (C160 I/F Board)
- ❑ Housing

### 1.5.1 Main Control Board (C160 MAIN Board)

The main control board (C160 MAIN Board) consists of an M37720 16-bit CPU, E05B08 gate array, a program ROM (4M), a PS-RAM (1M), a mask ROM (4M or 8M: If a 4M-bit program ROM is mounted on the board, an 8M-bit CG-ROM is mounted in location IC5, and if an 8M-bit program ROM is mounted on the board, there is no CG-ROM in location IC5.) and a 1K EEPROM. The reset IC (M51955 and PST 592) is equipped with both a logic system and a power system.

**Note:** During servicing, when you replace the program ROM, always install an 8M-bit program ROM regardless of the components mounted on that particular board. When you do this, the CG-ROM in location IC5 is ignored.

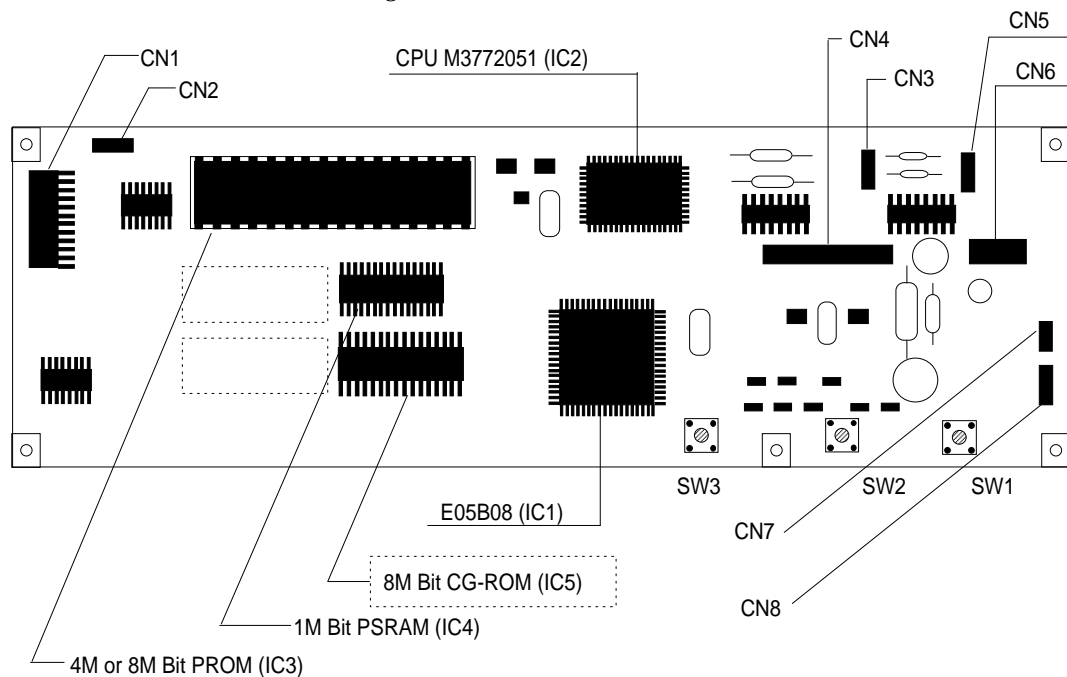


Figure 1-8. C160 Main Control Board Component Layout

### 1.5.2 Power Supply Board (C160 PSB/PSE Board)

The power supply board (C160 PSB/PSE Board) consists of an RCC switching regulator circuit. This board does not have a power switch connected to the secondary circuit like the Stylus Color series. Thus, if the printer is turned off, it cannot continue to operate in order to perform the head capping operation.

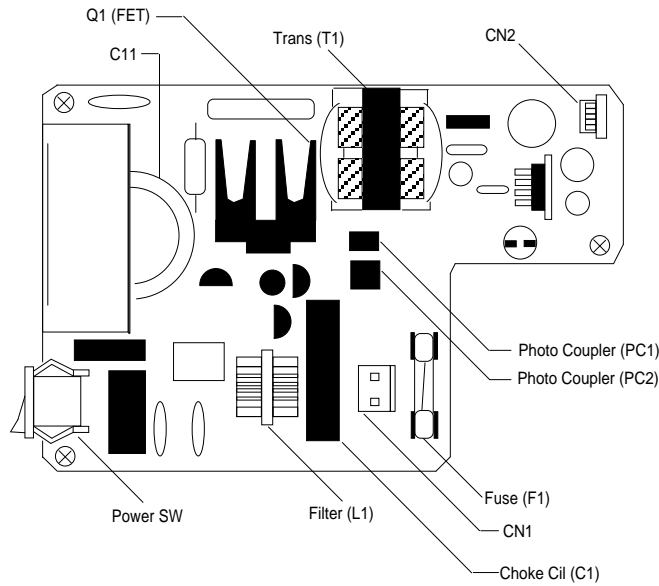


Figure 1-9. C160 PSB/PSE Board Component Layout

### 1.5.3 Interface Board (C160 I/F Board)

There is an exclusive interface board to receive/transmit print data between the host computer and printer.

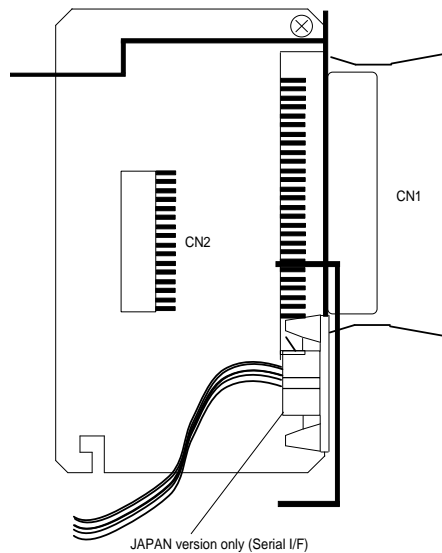


Figure 1-10. C160 I/F Board Component Layout

### 1.5.4 Printer Mechanism (M-4C10)

The M-4C10 printer mechanism is equipped with a replaceable 64-nozzle black printhead and 60-nozzle color (CMY) printhead, and it can print at a high resolution (720 dpi) using the special coated paper.

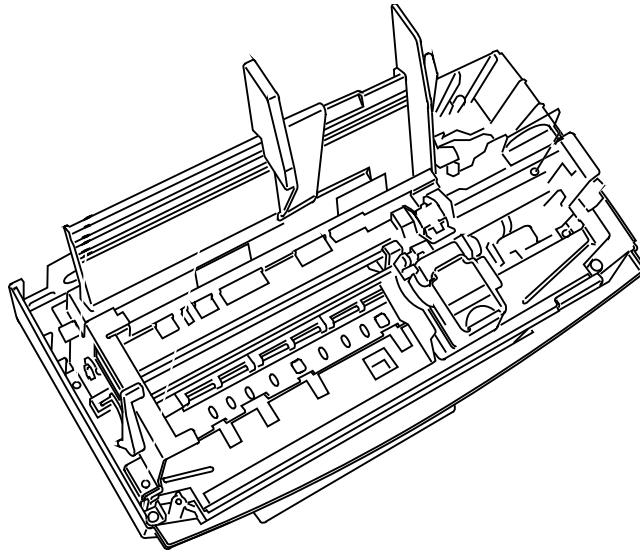


Figure 1-11. M-4C10 Printer Mechanism

### 1.5.5 Housing

The Stylus Color IIs housing consists of the printer cover, upper case, and lower case. Attached to the housing are the front paper support and ejected paper support with paper separator.

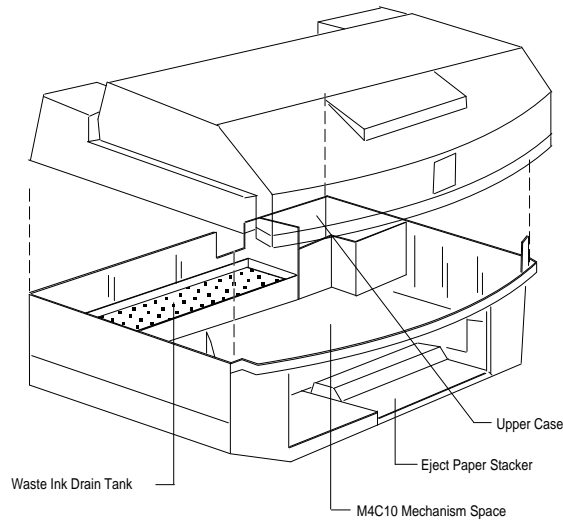


Figure 1-12. Housing Component Layout

# Chapter 2 Operating Principles

---

## Table of Contents

<b>2.1 OVERVIEW</b>	<b>2-1</b>
<b>2.2 OPERATING PRINCIPLES OF THE PRINTER MECHANISM</b>	<b>2-1</b>
2.2.1 Printer Mechanism	2-2
2.2.2 Printing Operations	2-4
2.2.3 Carriage Drive Mechanism	2-6
2.2.3.1 Platen Gap Adjust Laver	2-8
2.2.3.2 Paper Select Lever	2-9
2.2.4 Paper Feed Mechanism	2-10
2.2.5 Ink System	2-11
2.2.6 Pump Mechanism	2-12
2.2.7 Cap Mechanism	2-15
2.2.8 Wiping Mechanism	2-15
2.2.9 Carriage Lock Mechanism	2-16
<b>2.3 OPERATING PRINCIPLES OF THE ELECTRICAL CIRCUITS</b>	<b>2-17</b>
2.3.1 Operating Principles of the Power Supply Circuit	2-18
2.3.2 Operating Principles of the Main Control Circuit	2-20
2.3.2.1 Reset Circuits	2-21
2.3.2.2 Sensor Circuits	2-22
2.3.2.3 Carriage Motor Driver Circuit	2-23
2.3.2.4 Paper Feed Motor Driver Circuit	2-25
2.3.2.5 Printhead Driver Circuit	2-26

## List of Figures

Figure 2-1. Printer Mechanism Block Diagram . . . . .	2-1
Figure 2-2. Structure of Printhead . . . . .	2-2
Figure 2-3. Principles of the Printing Operation . . . . .	2-3
Figure 2-4. Dual Firing Method. . . . .	2-4
Figure 2-5. 720 dpi Printing for Stylus Color IIs (820) . . . . .	2-5
Figure 2-6. Carriage Mechanism . . . . .	2-6
Figure 2-7. PG Lever Operation . . . . .	2-8
Figure 2-8. Paper Select Lever . . . . .	2-9
Figure 2-9. Paper Feed Mechanism . . . . .	2-10
Figure 2-10. Ink System Block Diagram . . . . .	2-11
Figure 2-11. Trigger Lever Set . . . . .	2-12
Figure 2-12. Pump Transmission Block Diagram . . . . .	2-12
Figure 2-13. Trigger Lever Reset . . . . .	2-13
Figure 2-14. Gear Transmission Diagram . . . . .	2-13
Figure 2-15. Pump Operation . . . . .	2-14
Figure 2-16. Capping Operation . . . . .	2-15
Figure 2-17. Wiping Operation . . . . .	2-15
Figure 2-18. Carriage Lock Mechanism . . . . .	2-16
Figure 2-19. Block Diagram of the Circuit. . . . .	2-17
Figure 2-20. Power Supply Circuit Block Diagram . . . . .	2-18
Figure 2-21. Main Control Circuit Block Diagram . . . . .	2-20
Figure 2-22. Reset Circuit Block Diagram. . . . .	2-21
Figure 2-23. Sensor Circuit Block Diagram . . . . .	2-22
Figure 2-24. Carriage Motor Drive Circuit Block Diagram. . . . .	2-24
Figure 2-25. A2910 Internal Block Diagram . . . . .	2-24
Figure 2-26. PF Motor Drive Circuit Block Diagram. . . . .	2-25
Figure 2-27. Head Drive Circuit Block Diagram . . . . .	2-26
Figure 2-28. Head Drive Wave-form for Normal Printing. . . . .	2-26
Figure 2-29. Printhead Electrical Pole Configuration . . . . .	2-27

## List of Tables

Table 2-1. Differences Between Stylus Color and Stylus Color IIs in Micro-Weave Mode . . . . .	2-4
Table 2-2. Carriage Drive Motor Specifications. . . . .	2-6
Table 2-3. Drive Terms . . . . .	2-7
Table 2-4. Platen Gap Adjust Lever Position. . . . .	2-8
Table 2-5. Paper Select Lever Position . . . . .	2-9
Table 2-6. Paper Feed Drive Motor Specifications . . . . .	2-10
Table 2-7. Drive Terms . . . . .	2-10
Table 2-8. Pump Mechanism Operation . . . . .	2-14
Table 2-9. DC Voltage Distribution . . . . .	2-18
Table 2-10. Motor Drive Method (Clockwise Direction) . . . . .	2-23
Table 2-11. Connection Between Input and Output Signals . . . . .	2-23
Table 2-12. Connection Between Current Value and Input Signals . . . . .	2-24
Table 2-13. Motor Drive Method (Clockwise Direction) . . . . .	2-25



## 2.1 OVERVIEW

This section describes the operating principles for the printer mechanism and the circuits of the Stylus Color IIs.

## 2.2 OPERATING PRINCIPLES OF THE PRINTER MECHANISM

The Stylus Color IIs printer mechanism is composed of the printhead unit, paper feed mechanism, carriage drive mechanism, pump mechanism, and various sensors. The figure below shows a functional block diagram of the printer mechanism.

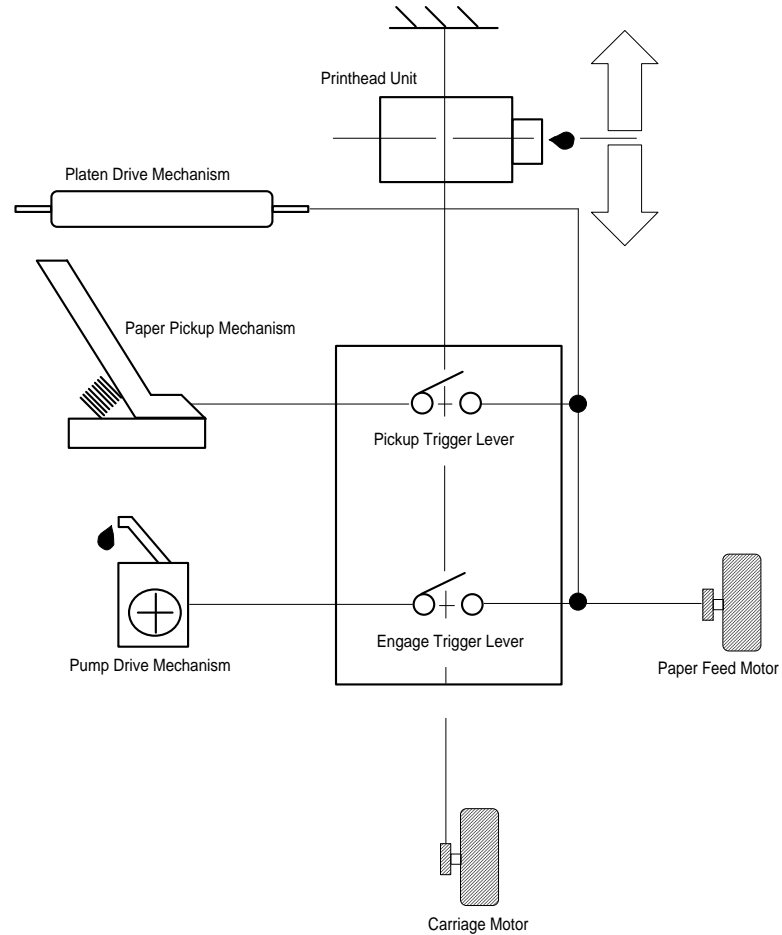
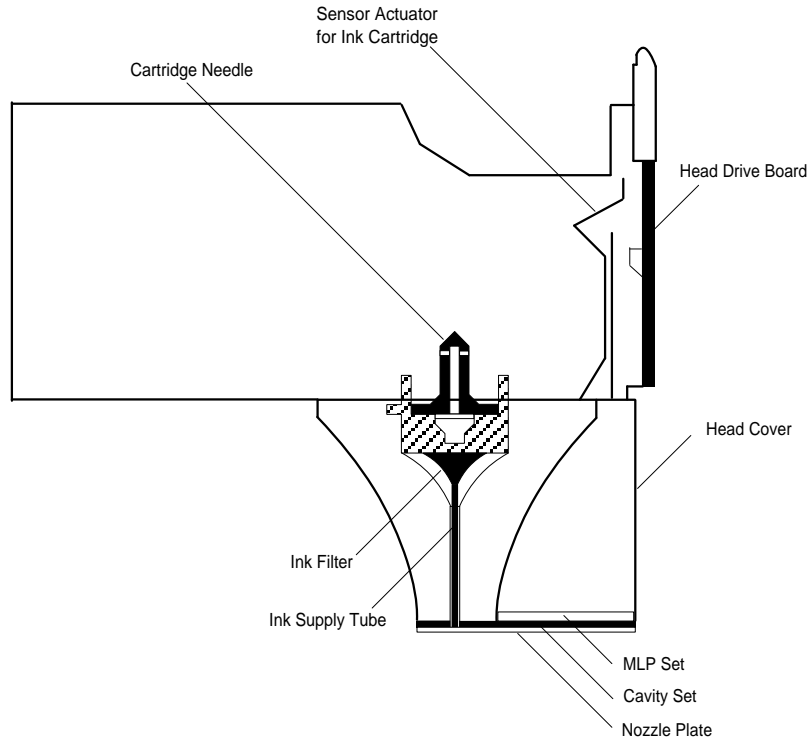


Figure 2-1. Printer Mechanism Block Diagram

### 2.2.1 Printer Mechanism

The printer mechanism for this printer uses a drop-on-demand ink jet system similar to the system used on all other EPSON ink jet printers. However, the printhead in this system has been completely redesigned to make it more compact and ensure a high level of reliability. The figure below shows the structure of the printhead and ink supply system.

- o Piezo When a drive pulse (voltage) is applied, this element pushes the vibration plate, compressing the cavity for ink ejection from the nozzle.
- o Cavity Ink supplied from the ink cartridge is stored in this space and is ejected from the nozzles when the vibration plate compresses this area.
- o Nozzles These eject ink against the paper's surface in response to the application of the print signal. There are 64 (black head) or 60 (color head) individual nozzles making up the printhead.

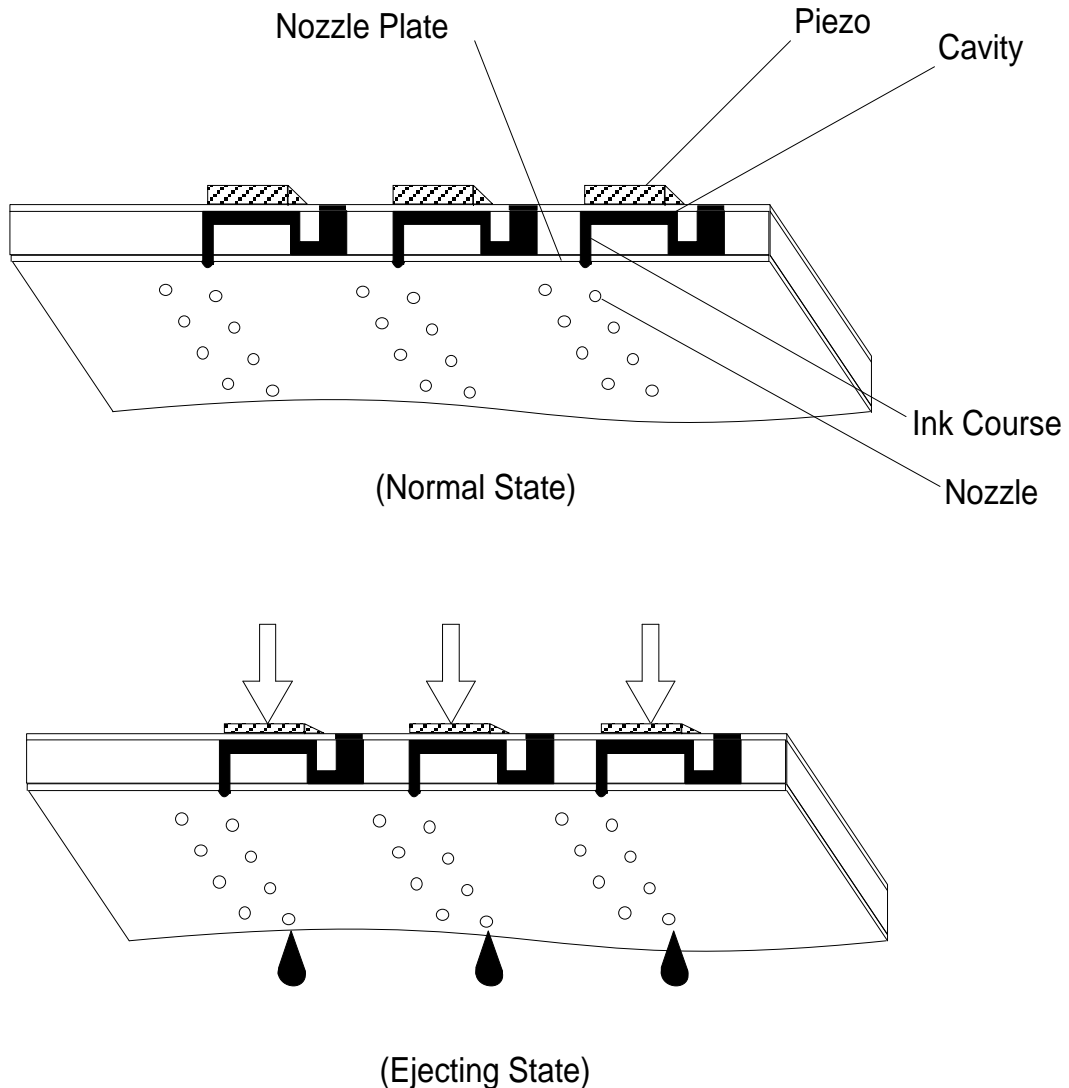


**Figure 2-2. Structure of Print Head**

### Principles of the Printing Operation

The printhead operates in one of two modes to eject ink from each nozzle:

- o Normal state  
No electrical charge is applied to the MLP (Multi-Layer Piezoelectric) element attached to the back of the cavity, and pressure inside the cavity is kept at a constant level.
- o Ejecting state



**Figure 2-3. Principles of the Printing Operation**

The head data signal is applied to the specific nozzle control line to select the active nozzle for printing, and the MLP element is gradually charged by the drive voltage. By charging the MLP element, the vibration plate is bent to compress the cavity. Then, ink is ejected from the nozzle.

When the ink charge or printhead cleaning operation is performed, the ink in the cavity is vacuumed out with the pump mechanism. During printing, on the other hand, ink is simultaneously supplied from the ink cartridge and ejected from the nozzle, depending on the change in the volume of the cavity.

A thermistor is attached to the side of each printhead unit to monitor the temperature, because the viscosity of ink varies, depending on the temperature. The detected temperature level is fed back to the printhead drive voltage control circuit to change the timing of the Tc pulse.

2.2.2 Printing Operations

Micro Weave Mode

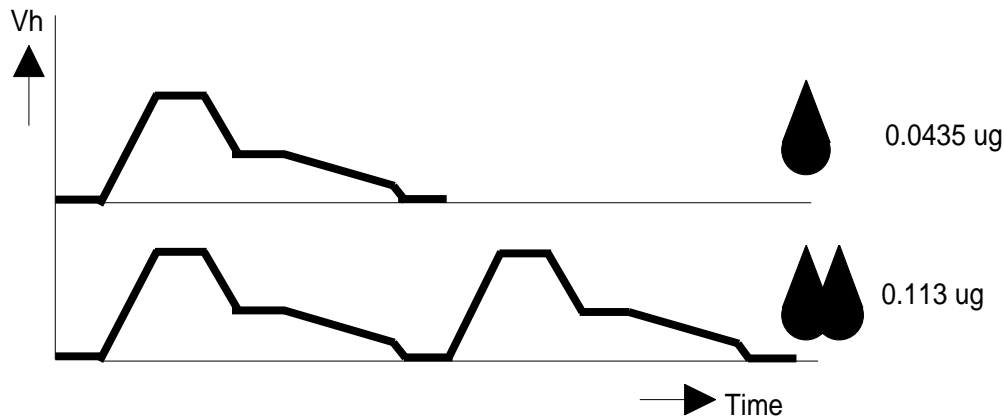
The Stylus Color IIs printer has a special printing mode, called “Micro Weave Printing Mode,” which can be selected from the custom printer driver. Using micro weave printing can improve the output quality, because it eliminates banding that can sometimes occur in normal mode. In micro weave mode, paper feed is performed after each print pass, eliminating pitch variations that cause the banding. The table below shows the differences between the Stylus Color printer and the Stylus Color IIs printer in the micro weave mode.

**Table 2-1. Differences Between Stylus Color and Stylus Color IIs in Micro Weave Mode**

Stylus Color	Stylus Color IIs
<ul style="list-style-type: none"> <li>o Using Nozzles</li> <li>Black Head: Only Row A (# 16 is not available.)</li> <li>Color Head: All Rows (# 16 is not available.)</li> </ul>	<ul style="list-style-type: none"> <li>o Using Nozzles</li> <li>Black Head: Only Row C and Row D (# 61 and # 64 nozzles not available.)</li> <li>Color Head: All Rows )</li> </ul>
<ul style="list-style-type: none"> <li>o Paper Feed Pitch</li> <li>15/360 inch (in 360 dpi mode)</li> <li>15/720 inch (in 720 dpi mode)</li> </ul>	<ul style="list-style-type: none"> <li>o Paper Feed Pitch</li> <li>20/360 inch (in 360 dpi mode)</li> <li>20/720 inch (in 720 dpi mode)</li> </ul>

Normal Mode

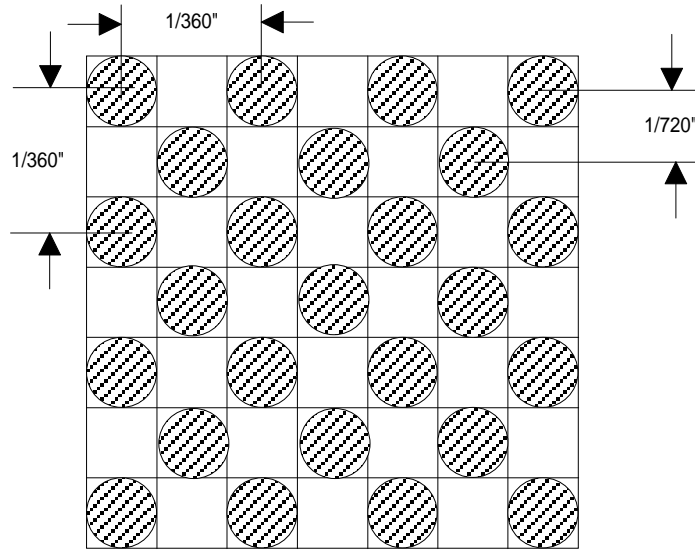
Normal printing mode is used for the black head at 360 dpi resolution on the custom printer driver. This mode is specially designed to decrease banding lines when the printer uses black ink (a low-penetrable type).



**Figure 2-4. Dual Firing Method**

**720 dpi Printing Mode**

The Stylus Color IIs has a special printing mode, called “720 dpi Printing Mode,” which also can be selected from the custom printer driver. In this mode, the printer prints dots as follows:



**Figure 2-5. 720 dpi Printing for Stylus Color IIs**

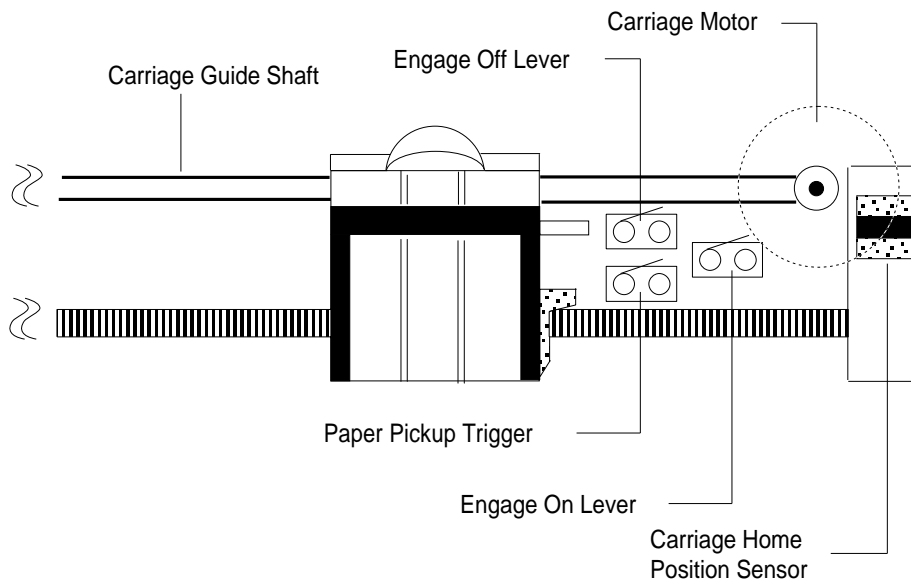
- o Resolution in the horizontal direction: True 360 dpi
- o Resolution in the vertical direction: 720 dpi, staggered

### 2.2.3 Carriage Drive Mechanism

The timing belt attached to the base of the carriage unit is driven by the carriage motor, which moves the carriage unit along the carriage guide shaft left to right, or vice versa. The carriage motor for this printer is a 4-phase, 48-pole, hybrid-type stepping motor mechanism, allowing the printer to stop the carriage or change carriage movement in any position. The position of the carriage is recognized by the home position sensor, and position information is fed back to the carriage drive control circuit. This carriage motor is driven by motor driver IC A72919 (See Section 2.3.2.3 for more information).

**Table 2-2. Carriage Drive Motor Specifications**

Item	Description
Motor Type	4-phase / 48-pole hybrid-type stepping motor
Drive Voltage	+42 VDC $\pm$ 5%
Coil Resistance	22.0 $\Omega$ $\pm$ 7%
Drive Frequency	768 ~ 3264 PPS
Excitation Mode	Constant current bi-polar drive, micro-step drive



**Figure 2-6. Carriage Mechanism**

Table 2-3. Drive Terms

CR Speed (cps)	Frequency (pps)	Phase Drive Method	Acceleration/Deceleration Step
SPD1 (170)	3264	1W1-2 phase	88 (22)
SPD2 (125)	2400	1W1-2 phase	88 (22)
SPD3 (20)	384	1W1-2 phase	8 (2)
SPD41 (20)	384	1W1-2 phase	8 (2)
SPD5 (40)	768	1W1-2 phase	8 (2)
SPD6 (40)	768	1W1-2 phase	8 (2)
SPD7 (40)	768	1W1-2 phase	8 (2)

**Note:** In the table above, 1 W1-2 phase means  $\frac{1}{4}$  2-2 phase drive control. Values in parentheses ( ) are for the 2-2 phase.

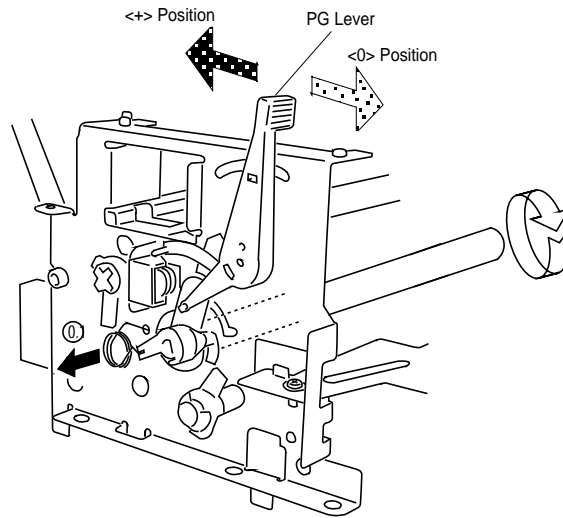
### 2.2.3.1 Platen Gap Adjust Lever

The platen gap adjust lever, which is attached to the left side of the printer mechanism, needs to be set to an appropriate position for the paper type. To change the platen gap (PG), put the printer in the pause state; then change the lever position from the <0> position to the <+> position.

**Note:** If print quality is not a problem, you do not need to change the lever position even if the paper thickness is changed.

**Table 2-4. Platen Gap Adjust Lever Position**

Paper Type	Lever Position
< 0 > position	Horizontal ( $\pm 0$ mm)
< + > position	Vertical (+ 0.62 mm)



**Figure 2-7. PG Lever Operation**

2.2.3.2 Paper Select Lever

The paper select lever, which is attached to the upper case, needs to be set to an appropriate position for paper-feed reliability. Change the paper select lever before transmitting data from the host computer.

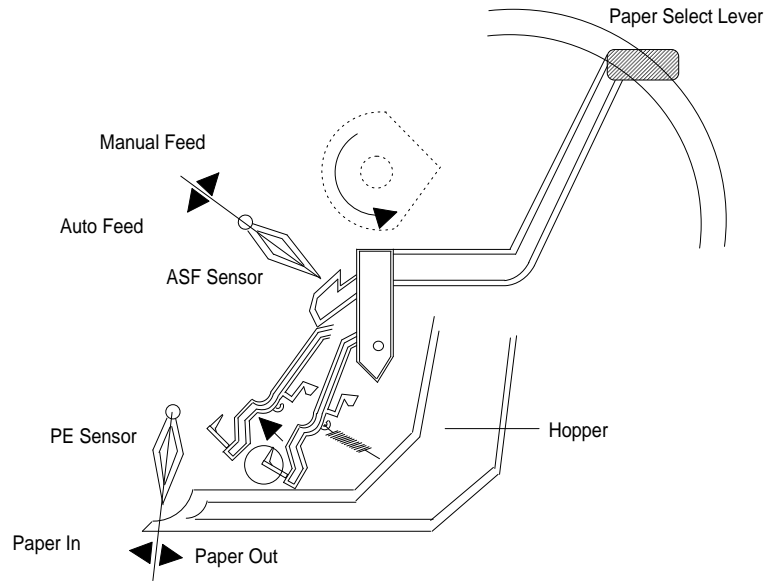


Figure 2-8. Paper Select Lever

**Note:** This operation changes paper pickup speed with the trigger switch on the ASF sensor.

- q Thinner paper: 1224 pps (Lever position: front)
- q Thicker paper: 625 pps (Lever position: rear)

The table below shows the connection between the paper used and the lever position.

Table 2-5. Paper Select Lever Position

Paper Type and Feed Method	Lever Position	PF Speed (PPS)
q Thinner paper, manual feed	Rear	1224
q Thinner paper, ASF feed	Front	1224
q Thicker paper, manual feed	Rear	1224
q Thicker paper, ASF feed	Rear	625

### 2.2.4 Paper Feed Mechanism

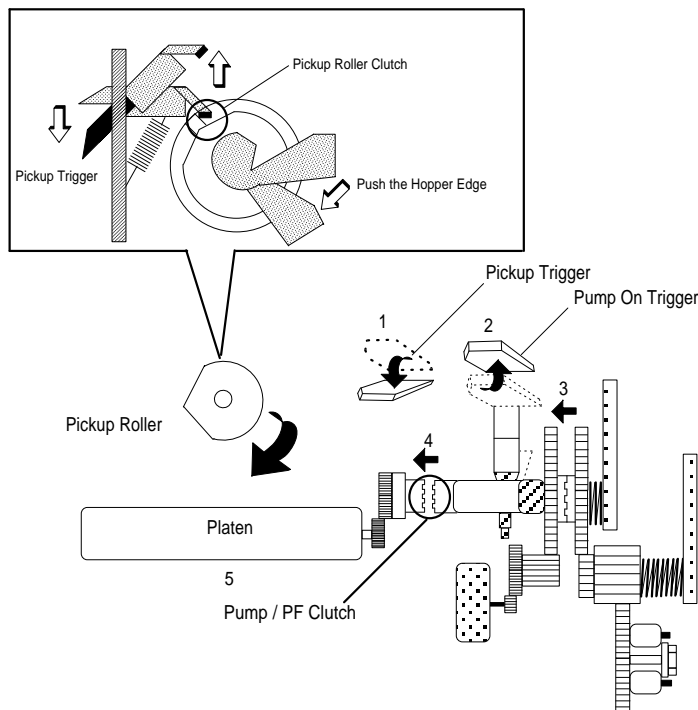
This printer's paper feed mechanism can feed paper only from the built-in ASF (auto sheet feeder). The paper feed drive motor is a 2-phase, 96-pole, hybrid-type stepping motor that directly drives the paper feed mechanism (paper advancing operation, paper pickup operation). This motor also drives the pump mechanism, but only when the printer is in the cleaning state. The paper feed drive method is driven by only the 2-2 phase drive method.

**Table 2-6. Paper Feed Drive Motor Specification**

Item	Description
Motor Type	2-phase, 96-pole, hybrid-type
Drive Voltage	+42 VDC ± 5%
Coil Resistance	21 Ω ± 1 Ω
Drive Frequency	500 ~ 1224 PPS
Excitation Mode	Open loop: 2-2 phase

**Table 2-7. Drive Terms**

Control Mode	Frequency (pps)	Drive Method	Purpose
Mode A	500	2-2 phase	PF (small steps)
Mode B	650	2-2 phase	PF (color micro weave)
Mode C	1224	2-2 phase	PF
Mode D	1224	2-2 phase	ASF drive
Mode E	650	2-2 phase	Pump drive
Mode F	500	2-2 phase	Eliminates backlash



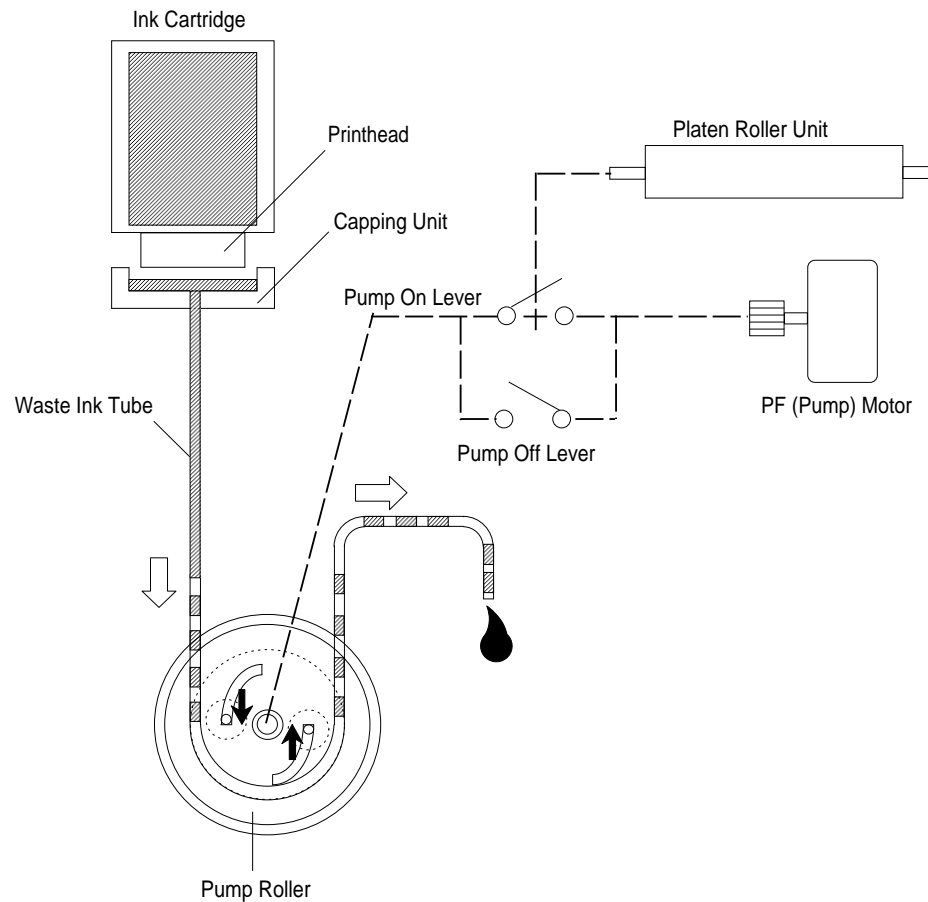
**Figure 2-9. Paper Feed Mechanism**

## 2.2.5 Ink System

This printer's ink system is composed of the following mechanisms:

- o Ink cartridge
- o Pump mechanism
- o Cap mechanism
- o Waste ink drain tank
- o Wiping mechanism
- o Carriage lock mechanism

The figure below gives a diagram of the ink system.

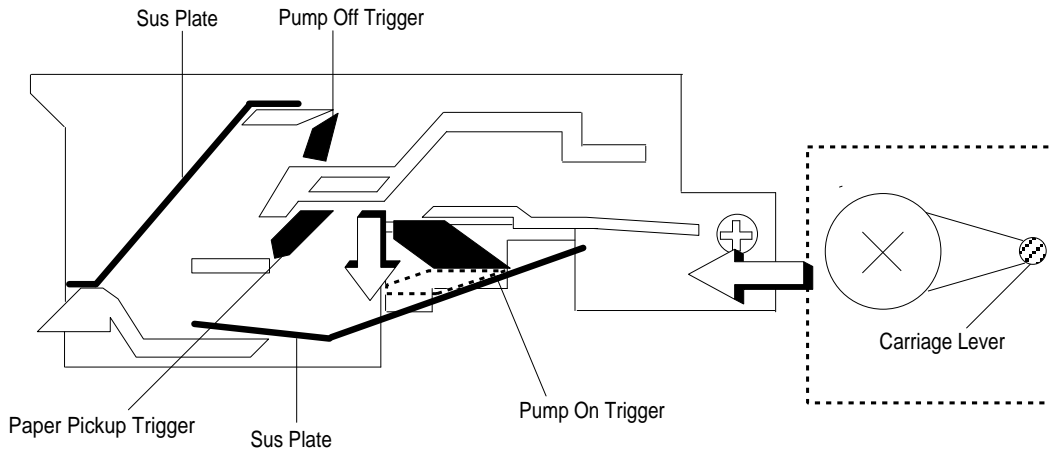


**Figure 2-10. Ink System Block Diagram**

### 2.2.6 Pump Mechanism

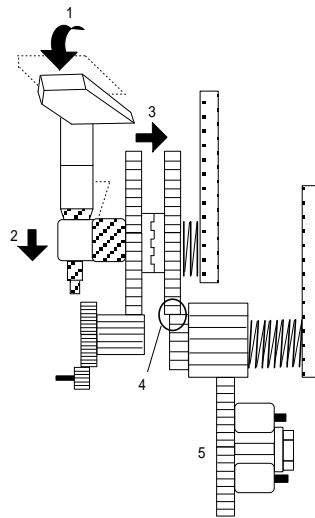
The paper feed motor drives the pump mechanism when the transmission gear is moved to the position where the paper feed motor engages the pump mechanism gear trains, when the carriage unit is at the ink system home position. The figure below shows a block diagram of the pump mechanism.

**Drive: Trigger Lever Set**



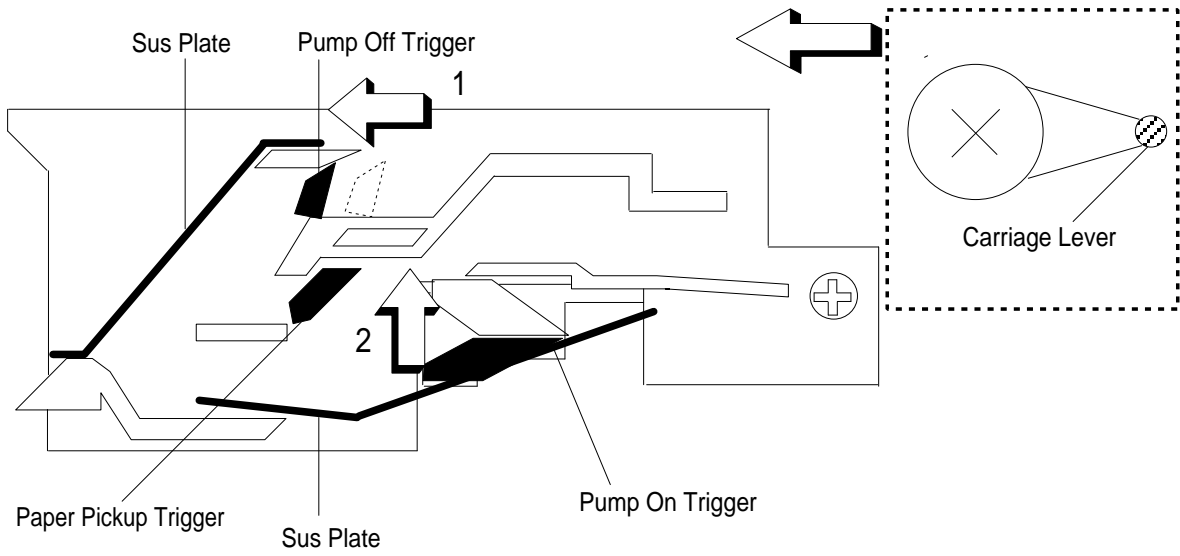
**Figure 2-11. Trigger Lever Set**

**Drive: Gear Transmission**



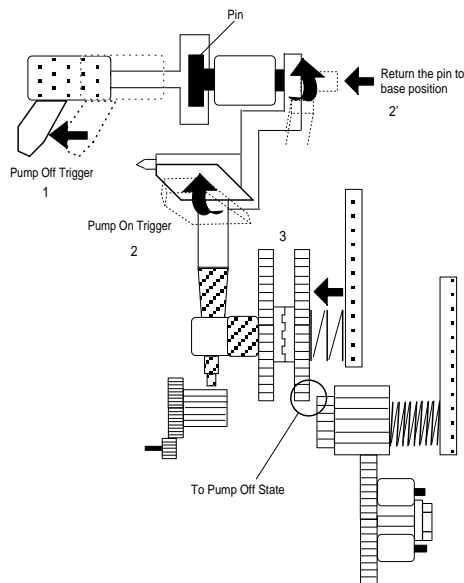
**Figure 2-12. Pump Transmission Block Diagram**

**Drive: Trigger Lever Reset**



**Figure 2-13. Trigger Lever Reset**

**Drive: Gear Transmission**

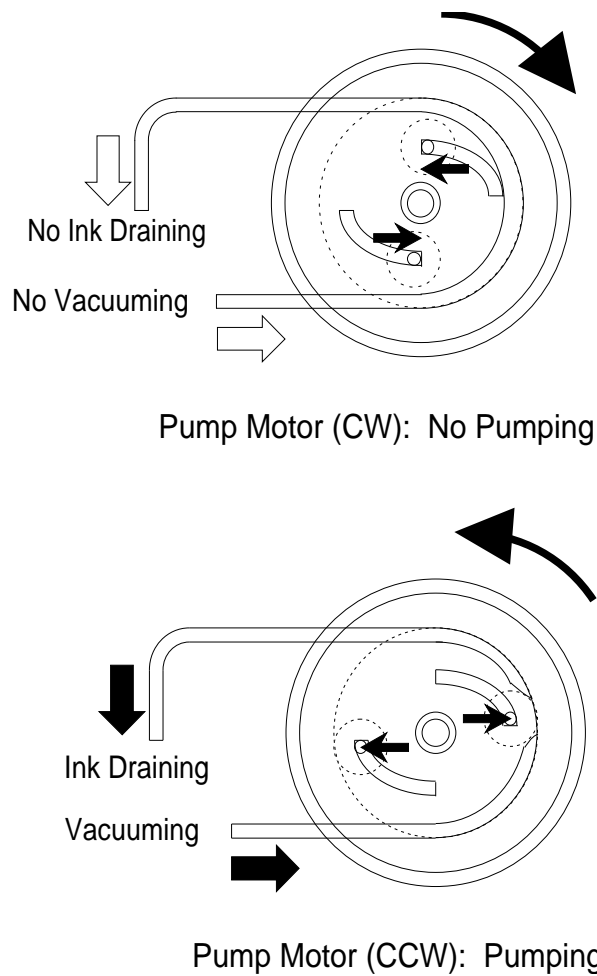


**Figure 2-14. Gear Transmission Diagram**

**Table 2-8. Pump Mechanism Operation**

PF Motor Rotational Direction	Operation
Clockwise (CW) Forward rotation	<ul style="list-style-type: none"> <li>o Absorption</li> <li>o False absorption</li> <li>o Drive transmission change</li> </ul>
Counterclockwise (CCW) Backward rotation	<ul style="list-style-type: none"> <li>o Absorption</li> <li>o False absorption</li> <li>o Cleaner set</li> <li>o Drive transmission change</li> </ul>

The pump draws ink from the printhead nozzles and drains it to the waste ink drain tank. The printer performs this operation to eliminate dust or bubbles in the nozzles. Figure 2-11 illustrates pump operation. When the paper feed drive motor rotates CCW (backward), the pulley pumps in the wheel pump unit rotate in the direction of the arrow while squeezing the ink tube to push the ink inside the tube out to the waste ink drain tank.



**Figure 2-15. Pump Operation**

### 2.2.7 Cap Mechanism

The cap mechanism prevents printhead nozzles from drying and keeps bubbles from forming inside the nozzles while the printer is not in use. The printer performs this operation automatically when print data is not received. (However, since the power switch is in the primary circuit, it does not allow auto capping when the user turns the printer off during printing.)

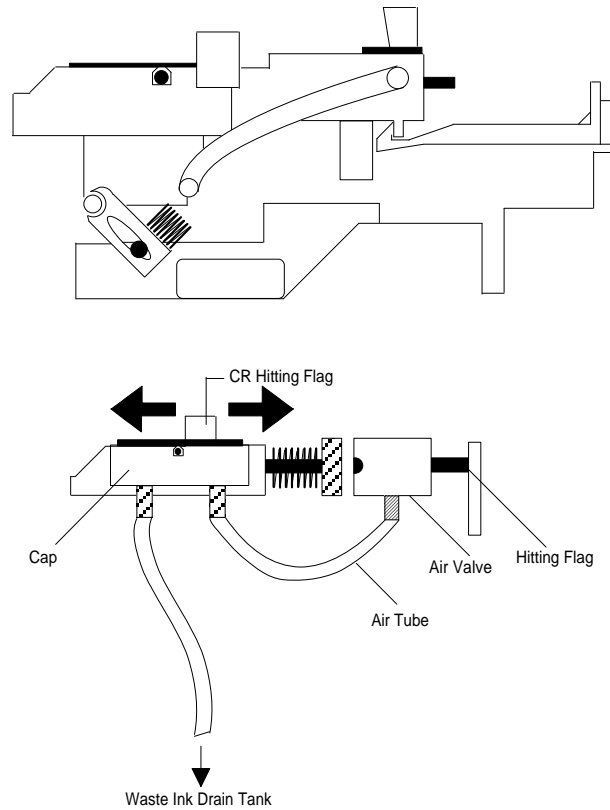


Figure 2-16. Capping Operation

### 2.2.8 Wiping Mechanism

The wiping mechanism cleans the surface of the printhead nose when the printer is in the ink system sequence. The wiper drive lever transmits to the pump drive gear via the cam friction roller. A tension spring in the cam friction roller holds the surface of cam friction roller against the inside of the pump roller.

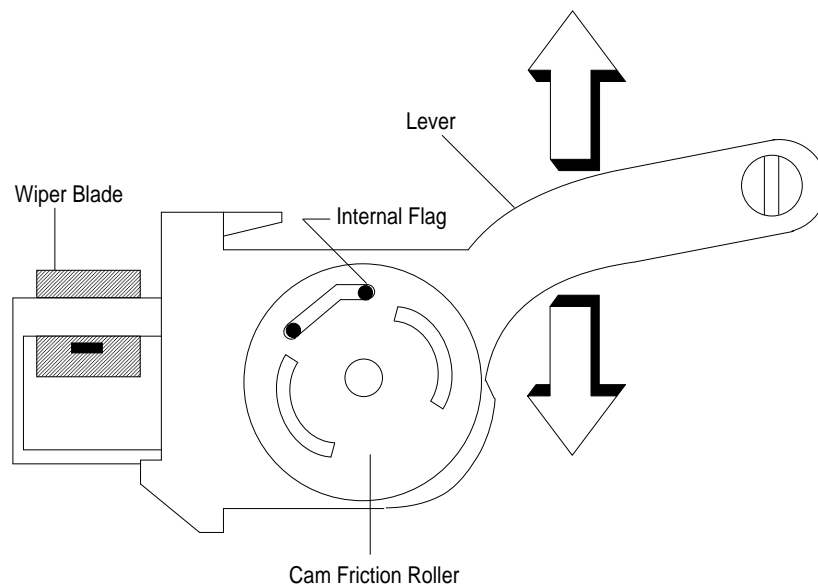
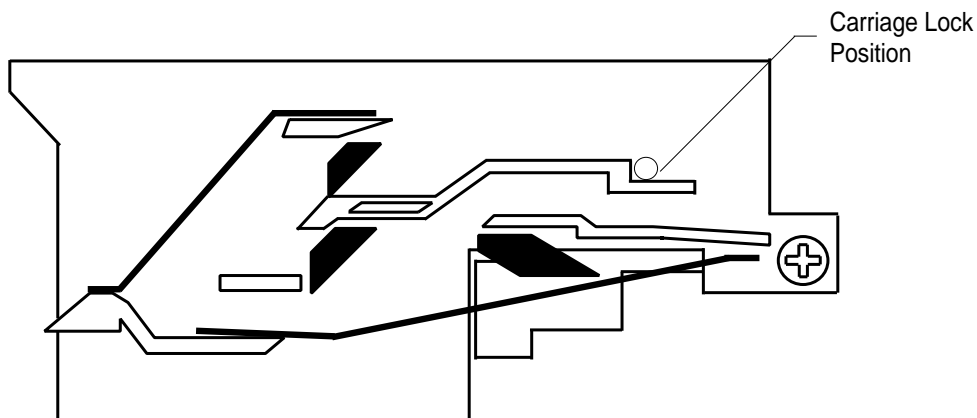


Figure 2-17. Wiping Mechanism

### 2.2.9 Carriage Lock Mechanism

The carriage lock mechanism locks the carriage unit when the printer is in the pause state or while it is not used. The Stylus Color IIs does not use an exclusive mechanism as the carriage lock. (The carriage lock position is on the engage / disengage rail as shown in the figure below.)



**Figure 2-18. Carriage Lock Mechanism**

**Note:** For servicing, it is very difficult to move the carriage unit to the carriage lock position manually. Therefore, it is necessary to turn the printer on, set the carriage unit to the lock position, and then turn the printer off.

### 2.3 OPERATING PRINCIPLES OF THE CIRCUITS

The Stylus Color IIs contains the following circuit board units:

- o C160 MAIN Board (main control circuit board)
- o C160 PSB/PSE Board (power supply circuit board)
- o C160 I/F (exclusive interface board)

In addition to the circuit boards above, part of the printhead drive circuit is built on a separate circuit board installed in the printhead unit; the printhead unit is attached directly to the carriage unit. The figure below shows a block diagram of the circuitry.

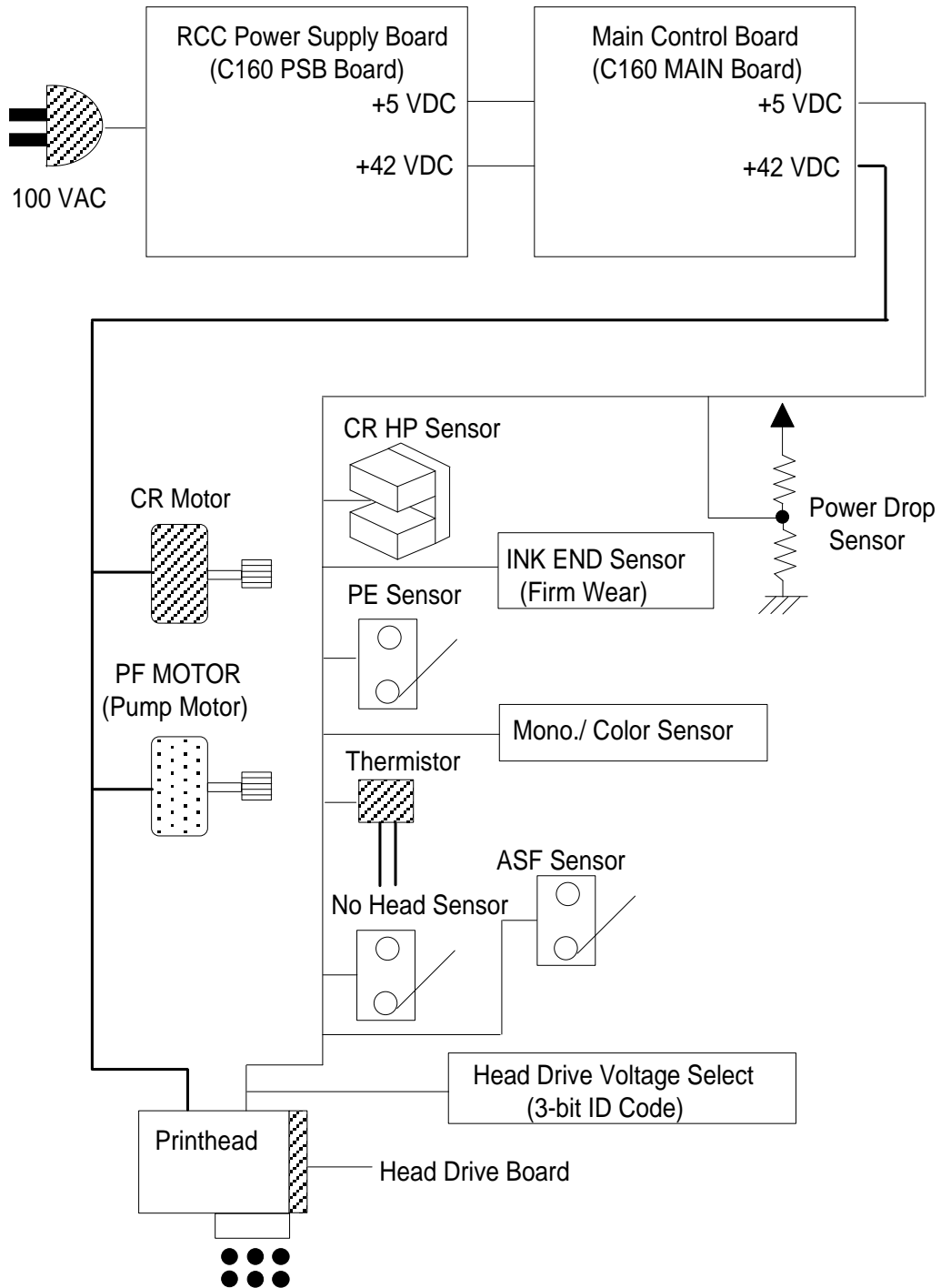


Figure 2-19. Block Diagram of the Circuits

### 2.3.1 Operating Principles of the Power Supply Circuit

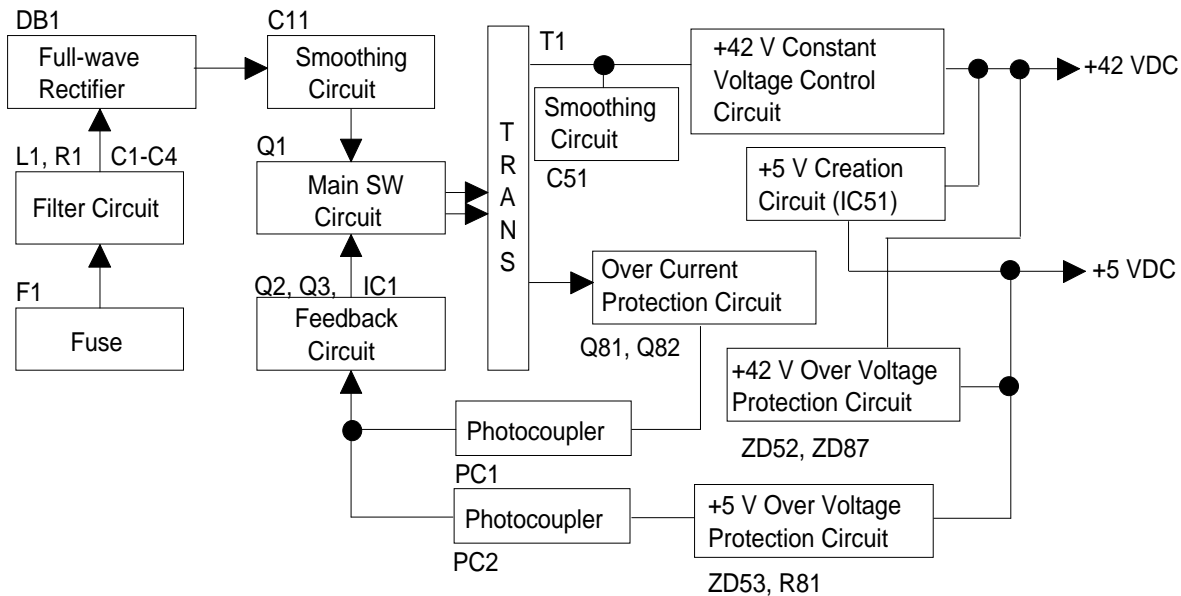
The power supply circuitry for this printer is provided either by the C160 PSB Board (120 VAC) or the C160 PSE Board (220-240 VAC). Both boards are identical in design and functionality, except for components in the primary circuit that accommodate the specified input voltage. The application of output voltages is summarized in the table below.

**Table 2-9. DC Voltage Distribution**

Voltage	Application
+42 VDC	Motor drive (carriage and paper feed / pump) Printhead (through the drive voltage generation circuit)
+5 VDC	C160 MAIN Board Sensors (home position, paper end, no ink cartridge, head thermistor, etc.) Control panel, head nozzle selector

The figure below shows a block diagram of the power supply circuit (C160 PSB/PSE). As opposed to Stylus Color series printers, the power switch for the Stylus Color IIs is in the primary circuit. Therefore, if the user turns off the printer during printing, the carriage unit stops without capping the nozzles.

Also, this board employs an RCC (ringing choke converter) switching system. This AC voltage is first input to the filter circuit for higher harmonics absorption, and then input to the rectification and smoothing circuit, converting it into a DC voltage. This DC voltage is then input to the switching circuit for the switching operation. Along with the switching operation on the primary side, +42 VDC is generated after passing through the +42 V line voltage-detection circuit. This +42 VDC output level is stabilized and also is input to the +5 VDC generation circuit (chopper IC) to generate a stable +5 VDC.



**Figure 2-20. Power Supply Circuit Block Diagram**

1. +5 VDC line over voltage protection circuit

The output voltage level of +5 V line is monitored by Zener diode ZD53. If the voltage level exceeds +6 V, the status is fed back to the primary switching circuit through photocoupler PC1 to stop the +42 V generation.

2. +5 VDC line over voltage control circuit.

The output current is monitored by a 2-pin detection port in IC51 and fed back to internal comparator; then the +5 VDC is generated.

3. +42 VDC line over voltage protection circuit

The output level is monitored by Zener diodes ZD52 and ZD87. If the voltage level exceeds +48 V, photocoupler PC2 is activated; stopping primary switching circuit operation.

4. +42 VDC line constant voltage control circuit

The output level of +42 VDC line is monitored by a detection circuit that consists of Zener diodes ZD51, 81, 82, 83, 84, 85, and 86. This circuit feeds back the output voltage level status through a photocoupler to the primary switching circuit to control the ON/OFF time of main switching FET Q1 for constant output voltage.

### 2.3.2 Operating Principles of the Main Control Circuit

The main control circuit for this printer is the C160 MAIN Board, which is controlled by the 16-bit CPU M3772 (IC2), running at 16 MHz. This CPU has a unique architecture capable of handling data on the data bus at either an 8-bit or 16-bit bus width. Because of this, a 16-bit or 8-bit data bus width-type ROM is used on this board, increasing the internal processing speed. Additionally, auto refresh for the 1M PS-RAM is controlled by custom gate array E05B08 (IC1).

Gate array E05B08 (IC1) manages printhead drive control, the parallel I/F, extension CG board, and the control panel. The gate array also manages the controls that create the 2-bit signal for the carriage or the paper feed motor. (The carriage and paper feed motors are controlled by current duty data with micro step control.) This board also is equipped with EEPROM 93C46 (IC10) to store certain parameters, such as the printer mechanism control parameters, default setting parameters, as well as the the value in the special counter used for printhead (ink management) protection.

Because this control board has no lithium battery that allows the printer to keep track of the amount of time that has elapsed since it was last used, there is no power on cleaning operation for this printer.

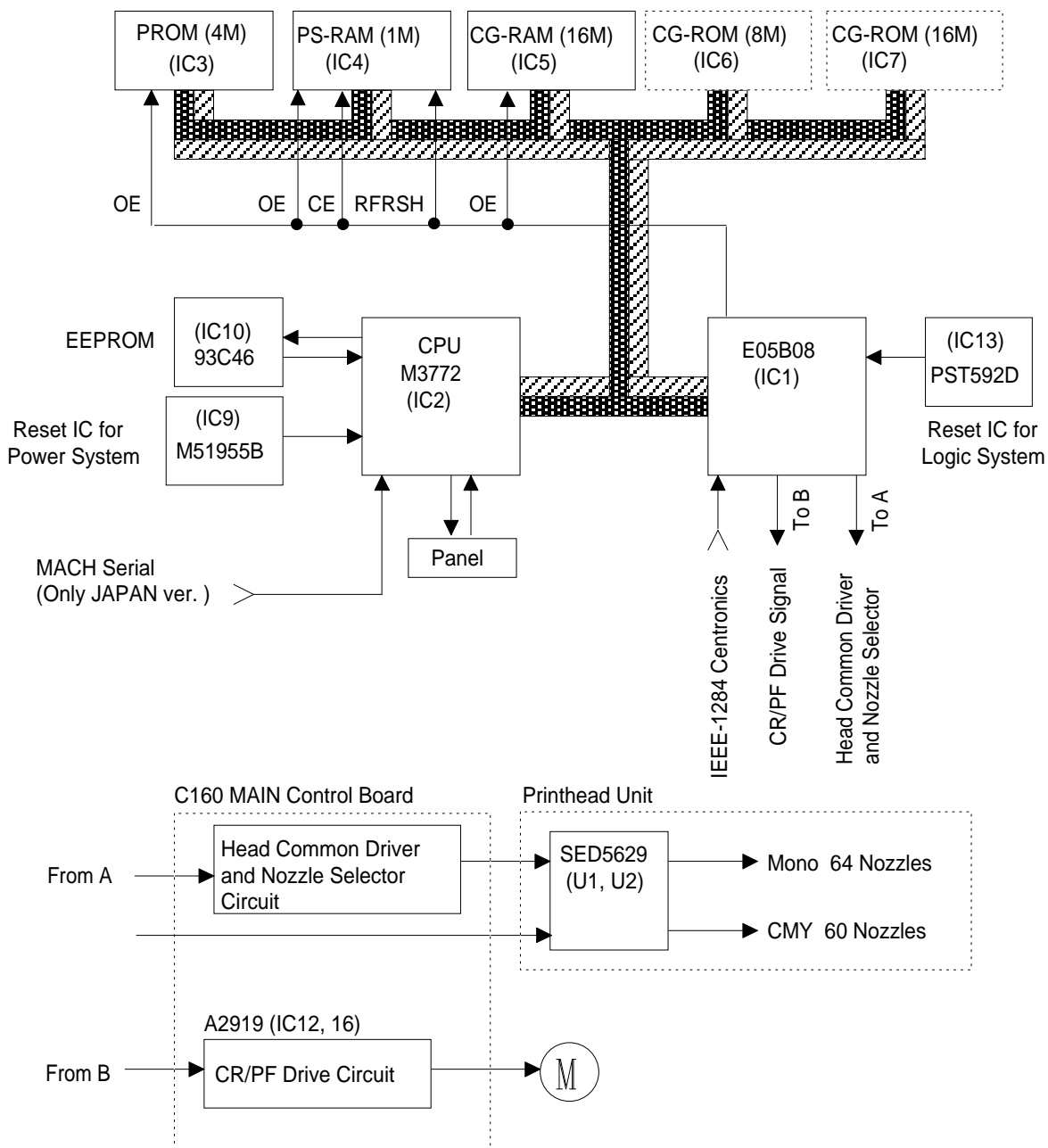


Figure 2-21. Main Control Circuit Block Diagram

### 2.3.2.1 Reset Circuits

The C160 MAIN Board contains 2 reset circuits: the +5 V monitor reset circuit and the +42 V monitor reset circuit. The +5 V monitor reset circuit checks the voltage level of the +5 V line, using reset IC PST592D (IC13), and outputs a reset signal to the E05B08 gate array (IC1) when the voltage level drops below +4.2 V. The +42 V monitor reset circuit checks the voltage level of the +42 V line, using reset IC M51955B (IC9), and outputs a reset signal to the CPU (IC2) when the voltage level drops below +40 V, and this causes a non-maskable interrupt (NMI).

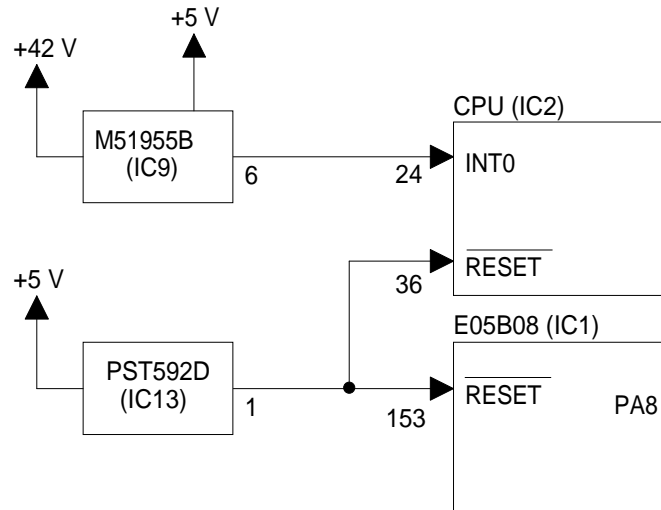


Figure 2-22. Reset Circuit Block Diagram

2.3.2.2 Sensor Circuits

The following sensor circuits enable the C162 MAIN Board to monitor printer mechanism status:

- HP sensor      The photocoupler-type home position (HP) sensor is attached to the surface of the printer mechanism to detect the carriage home position. A LOW level signal indicates the carriage is in home position.
- PE sensor      A mechanical switch-type paper end (PE) sensor is built into the printer mechanism to determine whether there is paper in the printer or not. A LOW level signal indicates no paper is loaded.
- CO sensor,      The cartridge out (CO) sensor is mechanical switch attached to the head unit.
- Thermistor      A thermistor is attached to the black or CMY printhead unit to monitor its temperature using the thermistor's resistance value (at 25° C or 77° F, approximately 10K Ω). The CPU changes the printhead drive signal's pulse width (PWM control) based on the temperature level.
- M/C sensor      The circuit pattern is decided as follows:  
                     q    Black head:      LOW  
                     q    CMY head:        HIGH  
 When the printhead is installed in the carriage unit, the control board recognizes the current head automatically.
- ID sensor      There are four ID ports in the head unit. When the printer is turned on, the control circuit decodes this ID data and outputs it automatically with the correct voltage. (During servicing, it is not necessary to install a resistor array onto the control board as with previous printers.)
- ASF sensor      If the user changes the paper select lever to manual feed mode, the ASF sensor monitors this and changes the paper feed sequence.

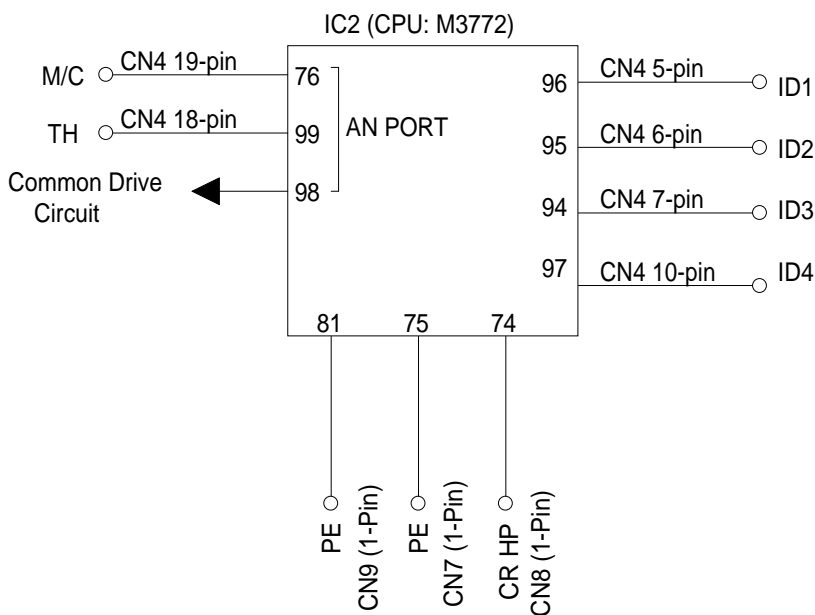


Figure 2-23. Sensor Circuit Block Diagram

### 2.3.2.3 Carriage Motor Driver Circuit

Carriage motor driver IC A2919 (IC12) outputs a constant current to drive the carriage motor. Gate array E05B08 (IC1) decides the motor phase and speed, and then sends a signal to the carriage motor driver IC using a 2-bit signal transmission line. (In the Stylus Color printer, 4-bit serial data was transmitted from the gate array to the driver IC.)

The carriage motor is controlled using a 1W1-2 phase method. 1W1-2 phase is  $\frac{1}{4}$  the 2-2 phase. (In the Stylus Color printer, the carriage motor was controlled using 2W1-2 phase.) The table below shows the motor drive method along with the micro steps.

**Table 2-10. Motor Drive Method (Clockwise Direction)**

Step	Phase A	Phase B
<b>1</b>	+2/3	+2/3
^	+1/3	+1
^	0	+1
^	-1/3	+1
<b>2</b>	-2/3	+2/3
^	-1	+1/3
^	-1	0
^	-1	-1/3
<b>3</b>	-2/3	-2/3
^	-1/3	-1
^	0	-1
^	+1/3	-1
<b>4</b>	+2/3	-2/3
^	+1	-1/3
^	+1	0
^	+1	+1/3

**Note:** One feature of driver IC A2919 is that it can gain constant torque by small movements of the carriage motor if  $\frac{1}{3} \times 1\text{TRIP}$  (TRIP = established current). Therefore, the driver sequence reflects that coefficient in the above table.

Also, the phase drive signal uses only two ports of IC A2919. The table below shows the connection between the input and output signals.

**Table 2-11. Connection Between Input and Output Signals**

Phase (Input Port)	OUT A	OUT B
H	H	L
L	L	H

**Note:** As shown above, two output signals are decided by only one input signal.

The figure below shows a block diagram of the carriage motor, and the Table 2-12 lists the connection between current control value and output current.

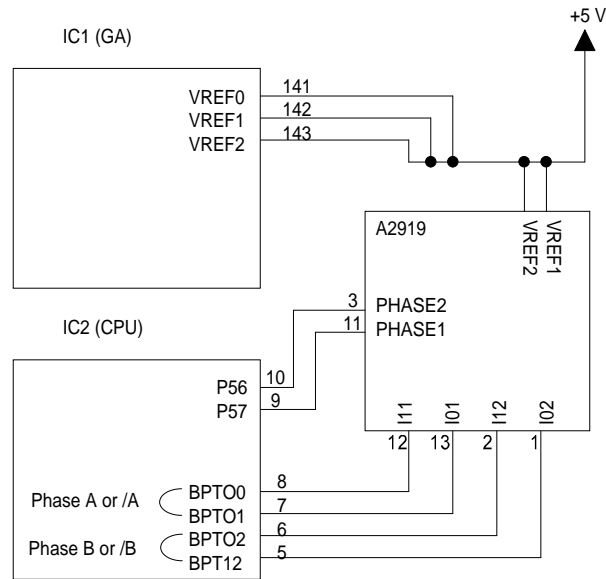


Figure 2-24. Carriage Motor Driver Circuit Block Diagram

Table 2-12. Connection between Current Value and Input Signal

I01 (I02)	I11 (I12)	Output Current
L	L	1 TRIP (100%)
H	L	2/3 TRIP (67%)
L	H	1/3 TRIP (33%)
H	H	0 (0%)

The micro step method is performed by PWM control in the driver IC, as shown below.

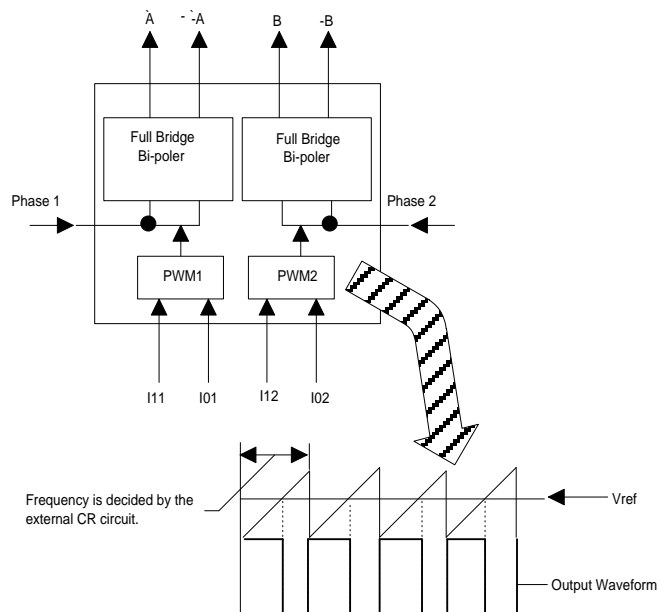


Figure 2-25. A2919 Internal Block Diagram

2.3.2.4 Paper Feed Motor Driver Circuit

The paper feed motor for this printer drives the following mechanisms:

- o Paper feed mechanism
- o Paper pickup mechanism
- o Pump mechanism

Driver IC A2919 (IC16) drives the paper feed motor by constant current. Its principle of operation is the same as for the carriage motor driver circuit. (However, the drive method is different from the carriage motor's.) Table 2-13 lists the motor drive method in the CW direction.

Table 2-13. Motor Drive Method (CW Direction)

Step	Phase A	Phase /A	Phase B	Phase /B
1	-	+	-	+
2	+	-	-	+
3	+	-	+	-
4	-	+	+	-

Note: The figure below shows a circuit diagram for the paper feed motor and motor driver IC.

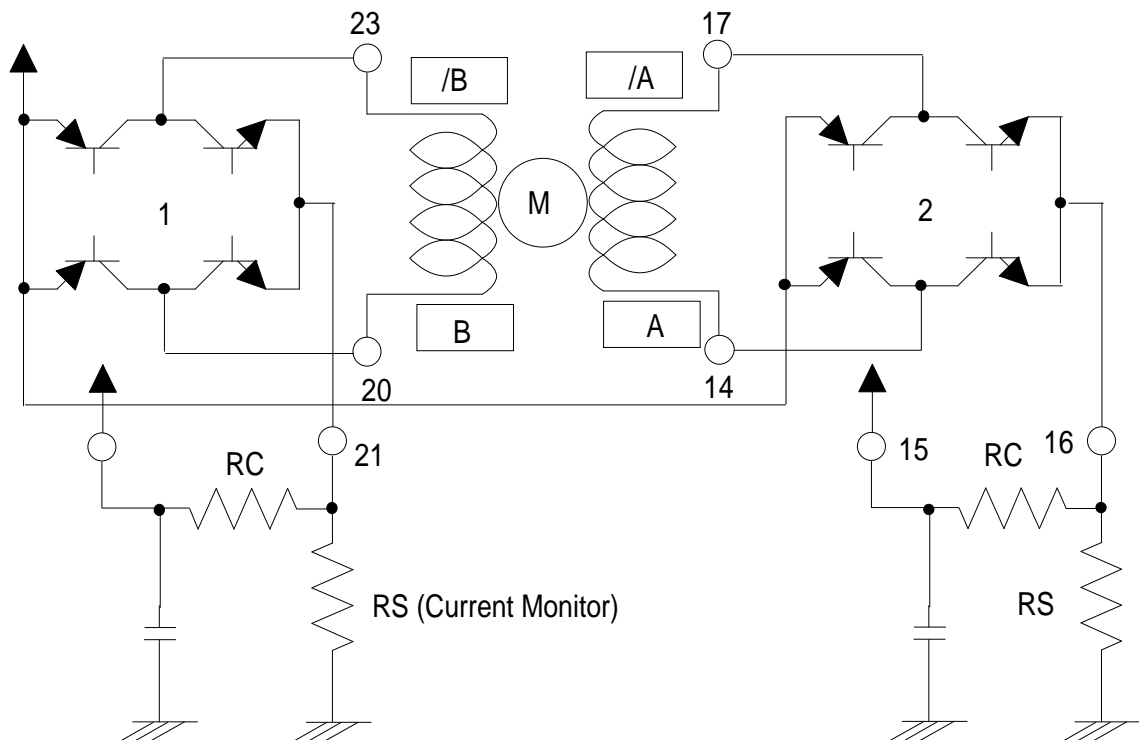


Figure 2-26. PF Motor Driver Circuit Diagram

### 2.3.2.5 Printhead Driver Circuit

The printhead driver circuit for this printer is composed of the following:

- o Common driver circuit (trapezoidal drive pulse generation)
- o Head driver circuit (nozzle control built on the printhead)

SED5619D, the 64-bit thermal head driver in the head drive circuit on the carriage, is used as a nozzle selector to drive printhead nozzles selectively. Print data is converted into serial data by gate array E05B08 (IC1) and is output from port SO (pin 13) to the black and CMY head driver circuits. Head driver SED5619D latches head data when gate array E05B08 outputs the LATCH signal, and the latched data becomes 64-bit parallel data for the black head or 60-bit parallel data for the CMY head. One bit corresponds to each nozzle.

When data transfer and nozzle selection is complete, gate array E05B08 outputs the common drive pulses (CHG (MCHG) signal, DCHG1 signal, DCHG2 signal, DCHG3 signal) to the common driver circuit. The common driver circuit then generates the trapezoidal pulse and applies it to the printhead as a common drive pulse. Then, the nozzle selected by the head data is activated to eject ink.

#### Normal Mode

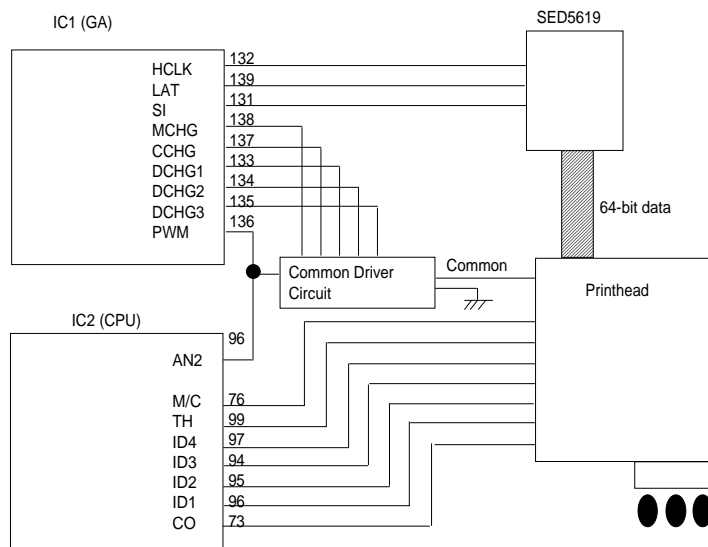
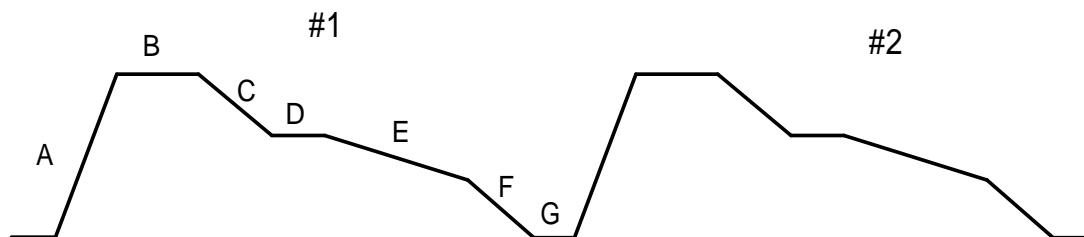


Figure 2-27. Head Driver Circuit Block Diagram

The normal mode for the Stylus Color IIs operates differently from the normal mode for other Stylus printers. The printer uses normal mode printing only when the user selects 360 dpi printing with the custom printer driver. (Refer to Section 2.2.2. ) The figure below shows the head drive waveform for normal mode.

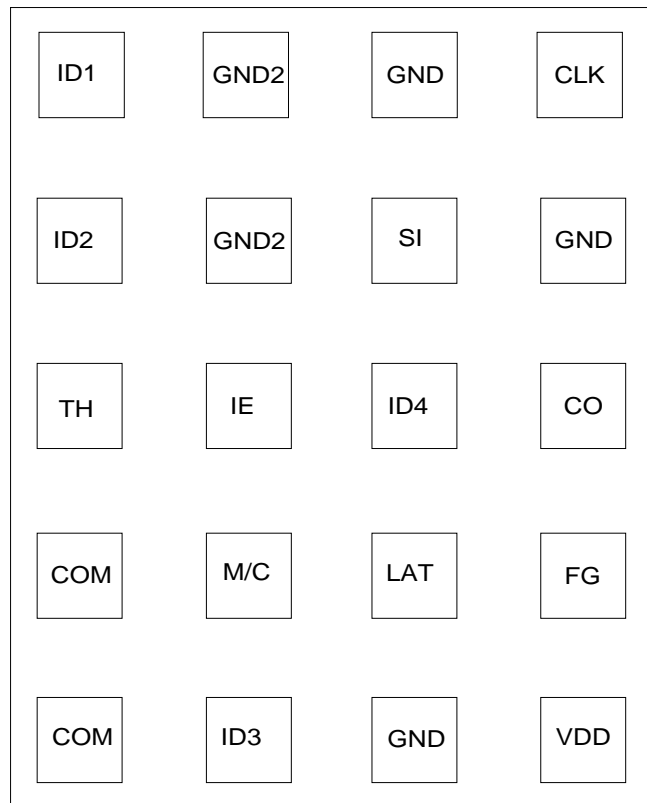
Note: If single firing is performed, printer outputs only wave # 1.



- A: 1st charge, B: 1st hold, C: 1st discharge
- D: 2nd hold, E: 2nd discharge
- F: 3rd discharge, G: pause

Figure 2-28. Head Driver Waveform for Normal Mode

The electrical pole configuration on the printhead unit is as follows:



**Figure 2-29. Printhead Electrical Pole Configuration**

SI Signal: For transmitting 64-bit serial data to the SED5619D

LAT: The latch trigger for 64-bit serial data in the driver IC (SED5619D)

CLK: The standard trigger for driving serial transmission

*Note:* Refer to Section 2.3.2.2 about the other signals.

# Chapter 3 Disassembly and Assembly

---

## Table of Contents

<b>3.1 OVERVIEW</b>	<b>3-1</b>
<b>3.1.1 Precautions for Disassembling the Printer</b> .....	<b>3-1</b>
<b>3.2 DISASSEMBLY AND ASSEMBLY</b>	<b>3-2</b>
<b>3.2.1 Upper Case Removal</b> .....	<b>3-2</b>
<b>3.2.2 C160 Main Board Removal</b> .....	<b>3-3</b>
<b>3.2.3 C160 I/F Board Removal</b> .....	<b>3-4</b>
<b>3.2.4 C160 PSB/PSE Board Removal</b> .....	<b>3-5</b>
<b>3.2.5 M-4C10 Printer Mechanism Removal</b> .....	<b>3-6</b>
<b>3.2.6 Printer Mechanism Disassembly</b> .....	<b>3-7</b>
<b>3.2.6.1 Carriage Unit Removal</b> .....	<b>3-7</b>
<b>3.2.6.2 ASF Unit Removal</b> .....	<b>3-9</b>
<b>3.2.6.3 PE Sensor Removal</b> .....	<b>3-9</b>
<b>3.2.6.4 Pick Up Roller Unit Removal</b> .....	<b>3-10</b>
<b>3.2.6.5 Carriage Home Position Sensor Removal</b> .....	<b>3-10</b>
<b>3.2.6.6 Paper Feed Roller Unit Removal</b> .....	<b>3-11</b>
<b>3.2.6.7 Carriage Motor Removal</b> .....	<b>3-11</b>
<b>3.2.6.8 Head Cleaner Replacement Removal</b> .....	<b>3-12</b>
<b>3.2.6.9 Pump Unit Removal</b> .....	<b>3-13</b>
<b>3.2.6.10 Paper Feed Motor Removal</b> .....	<b>3-14</b>

## LIST OF FIGURES

Figure 3-1. Upper Housing Removal . . . . .	3-2
Figure 3-2. C160 Main Control Board Removal . . . . .	3-3
Figure 3-3. ASF Sensor Removal. . . . .	3-3
Figure 3-4. FFC Cable Removal . . . . .	3-4
Figure 3-5. C160 I/F Board Removal. . . . .	3-4
Figure 3-6. C160 PSB/PSE Board Removal . . . . .	3-5
Figure 3-7. Printer Mechanism Removal. . . . .	3-6
Figure 3-8. PG Lever and Tension Coil Removal. . . . .	3-7
Figure 3-9. Parallelism Adjust Lever Removal . . . . .	3-8
Figure 3-10. Carriage Unit Removal . . . . .	3-8
Figure 3-11. ASF Unit Removal . . . . .	3-9
Figure 3-12. PE Sensor Removal. . . . .	3-9
Figure 3-13. Pick Up Roller Unit Removal. . . . .	3-10
Figure 3-14. Carriage Home Position Sensor. . . . .	3-10
Figure 3-15. Paper Feed Roller Unit Removal . . . . .	3-11
Figure 3-16. Carriage Motor Removal . . . . .	3-11
Figure 3-17. Head Cleaner Replacement. . . . .	3-12
Figure 3-18. Cap Unit Removal . . . . .	3-13
Figure 3-19. Pump Unit Releasing. . . . .	3-13
Figure 3-20. Pump Unit Removal. . . . .	3-14
Figure 3-21. Paper Feed Motor Removal. . . . .	3-14
Figure 3-22. Head Data Indication . . . . .	3-20

## 3.1 OVERVIEW

This section describes procedures for disassembling the main components of the printer. Unless otherwise specified, disassembled units or components can be reassembled by reversing the disassembly procedure. Therefore, no assembly procedures are included. Precautions for any disassembly or assembly procedure are described under the heading "Disassembly/Assembly Points." Adjustments required after assembling the unit are described under the heading "Required Adjustments."

### 3.1.1 Precautions for Disassembling the Printer

See the precautions below when disassembling the printer.

#### **WARNING**

- o *Disconnect the power cable before disassembling or assembling the printer.*
- o *Wear goggles to protect your eyes from ink. If ink gets in your eye, flush it with fresh water and see a doctor immediately.*
- o *If ink comes into contact with your skin, wash it off with soap and water. If irritation occurs, contact a physician.*

#### **CAUTION 1**

- o *Use only O9 oil when lubricating the carriage guide shaft.*

#### **CAUTION 2**

- o *Never remove the ink cartridge from the carriage unless manual instructions specify to do so.*
- o *When transporting the printer after installing the ink cartridge, be sure to pack the printer for transportation without removing the ink cartridge.*
- o *Use only recommended tools for disassembling, assembling, or adjusting the printer.*
- o *Apply lubricants and adhesives as specified. (See Chapter 6.)*
- o *Make specified adjustments when you disassemble the printer. (See Chapter 4.)*

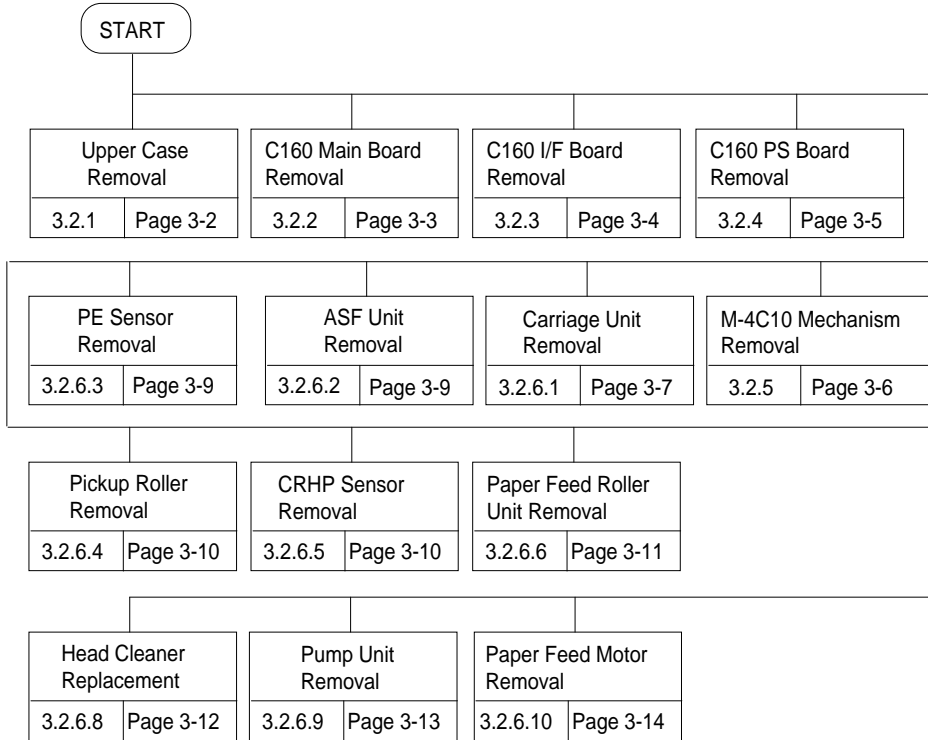
## 3.2 DISASSEMBLY AND ASSEMBLY

This section consists of the subheads shown in the diagram below. See the exploded view of the printer in the Appendix, if necessary.

#### **WARNING**

- o *Follow the precautions in Section 3.1.1 when disassembling the printer.*

This section consists of the subheads shown in the diagram(next page).

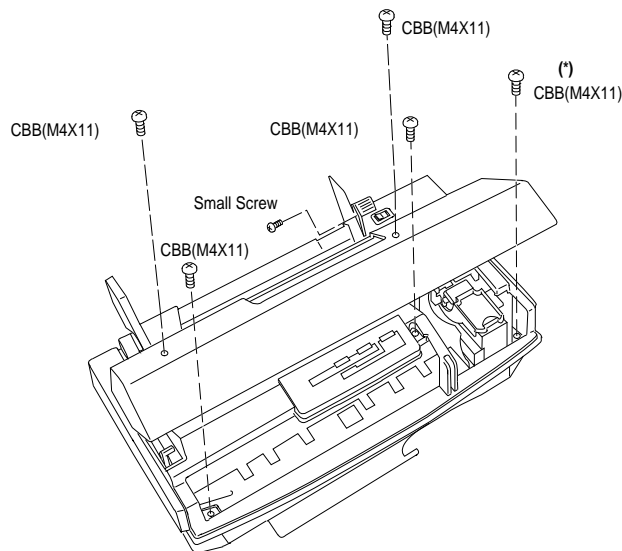


### 3.2.1 Upper Case Removal

1. Remove the sheet guide from main unit. Then remove 2 CBB (M4 × 11) screws securing the upper case to the bottom case.
2. Open the front cover; then remove 2 CBB (M4 × 11) screws securing the upper case to the bottom case.
3. Remove 1 small screw securing the ASF knob to the lever.
4. Remove the upper case by lifting the front side.

#### **DISASSEMBLY/ASSEMBLY POINT**

*When you move the carriage unit manually to remove 1 screw(\*), push it once toward the right, and move to the left side .*



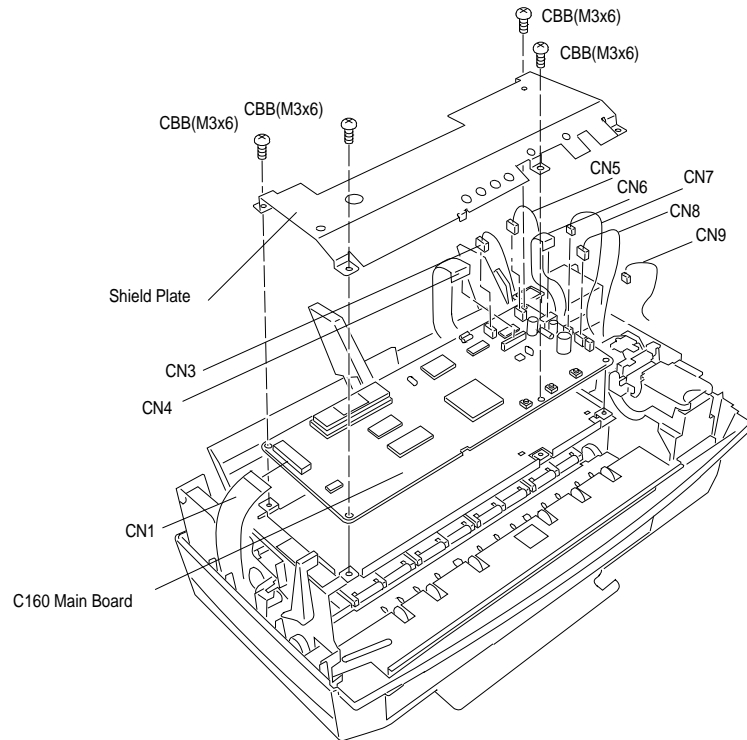
**Figure 3-1. Upper Case Removal**

### 3.2.2 C160 MAIN Control Board and ASF Sensor Removal

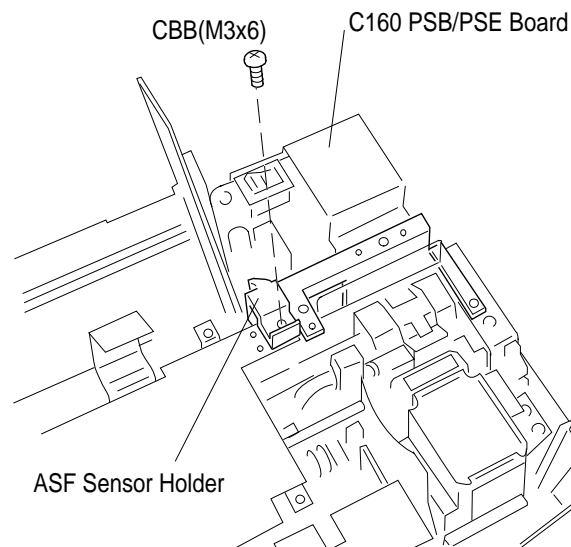
1. Remove the upper case (see Section 3.2.1).
2. Remove 4CBB (M3×6) screws attaching the shield frame to the C160 MAIN Board.
3. Remove 7 connectors (CN1, CN8, CN7, CN4, CN3, CN5, CN6) on the main board. (Push CN6 down to release cable on main board.) Then remove the C160 Main Control Board.
4. Remove a CBB (M3x6) screw fixing a ASF Sensor holder to printer mechanism.

#### **CAUTION**

*When you replace the C160 MAIN Board, reset the EEPROM and perform the required adjustments. (See Chapter 4.)*

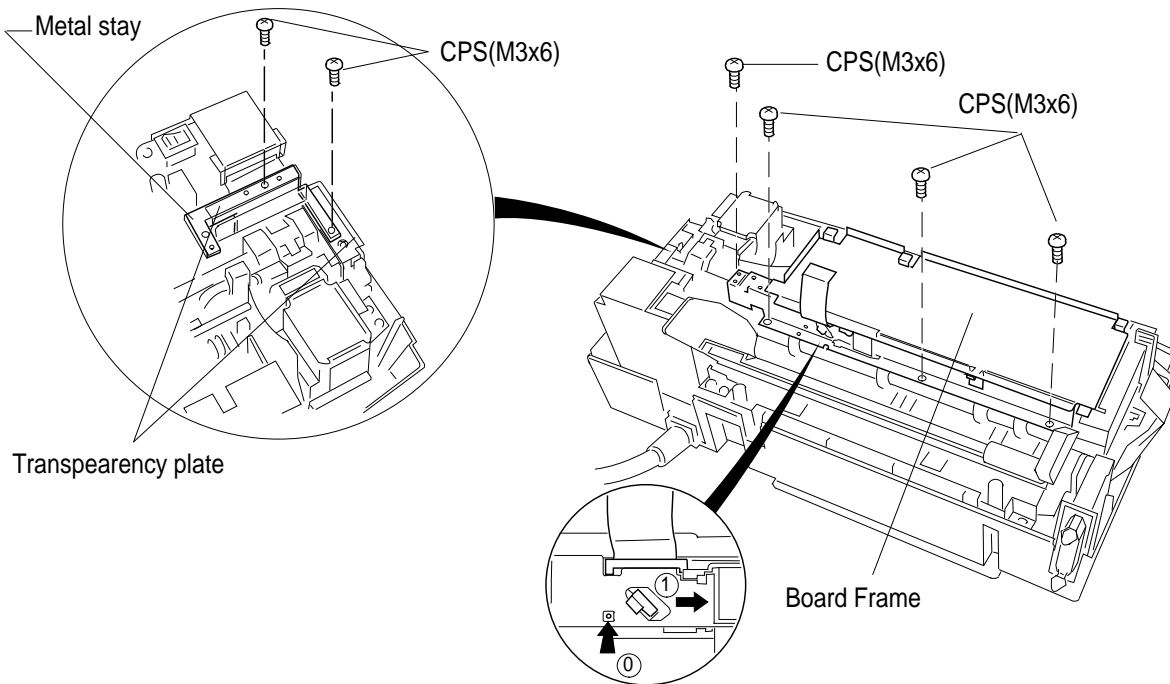


**Figure 3-2. C160 Main Control Board Removal**



**Figure 3-3. ASF Sensor Removal**

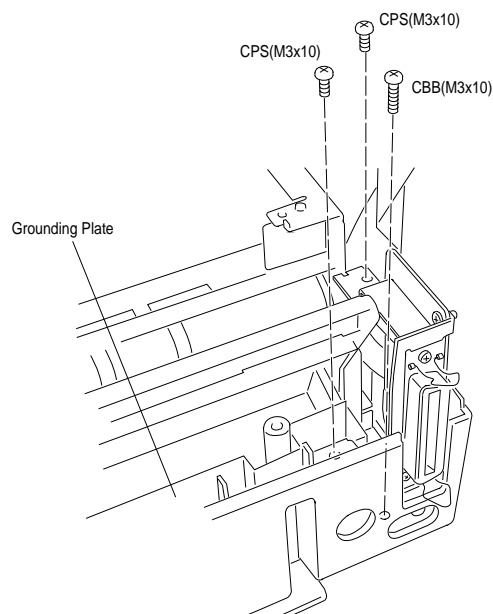
5. Remove 3 CPS (M3×6) screws fixing the board frame to the mechanism and 1 CPS (M3×6) screw fixing the metal stay between the board frame and the side(right) frame. Then remove the metal stay.
6. Remove 2 CPS (M3×6) screws fixing the transparency plate, then remove it.
7. Release the 3 hooks securing the FFC cable to the board frame then remove the board frame.



**Figure 3-4. Board Frame and Metal Stay Removal**

### 3.2.3 C160 I/F Board Removal

1. Remove the upper case (see Section 3.2.1).
2. Remove 2 CPS (M3×6) screws and 1 CBB (M3×10) securing the C106 I/F Board to the mechanism and bottom case.
3. Disconnect CN1 on this board; then remove it by lifting it up.



**Figure 3-5. C160 I/F Board Removal**

### 3.2.4 C160 PSB/PSE Board Removal

1. Remove the upper case (see Section 3.2.1).
2. Remove 1 CBB (M3×10) screw securing the power supply board to the lower case, 1 CPS (M3×6) screw securing the board frame to the grounding plate, 1 CBB (M3×10) screw fixing the board frame and 1 big screw securing the board frame to the lower case via the grounding plate.

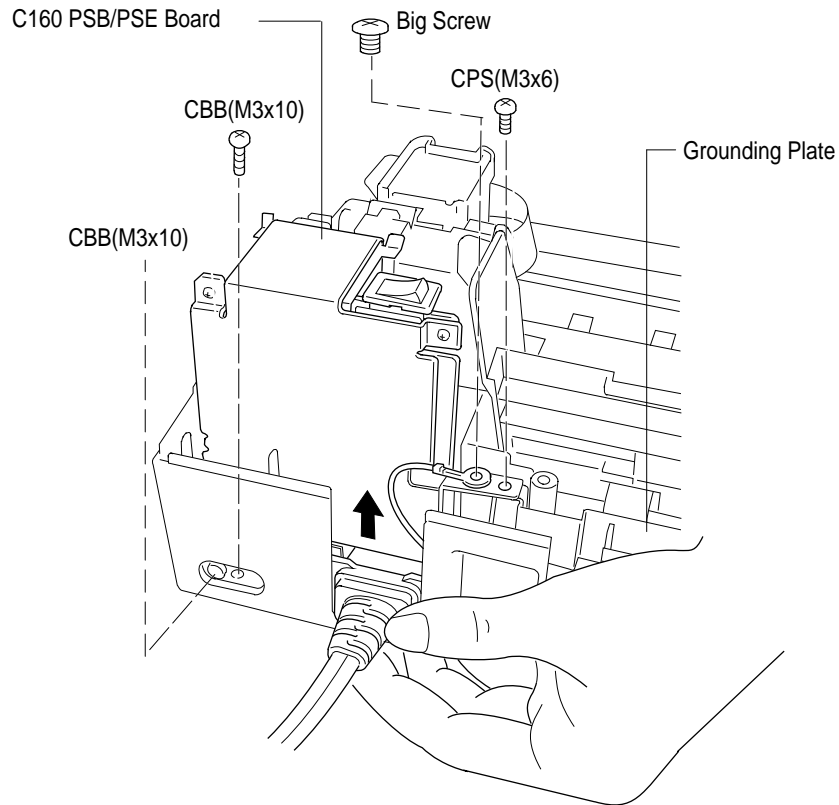


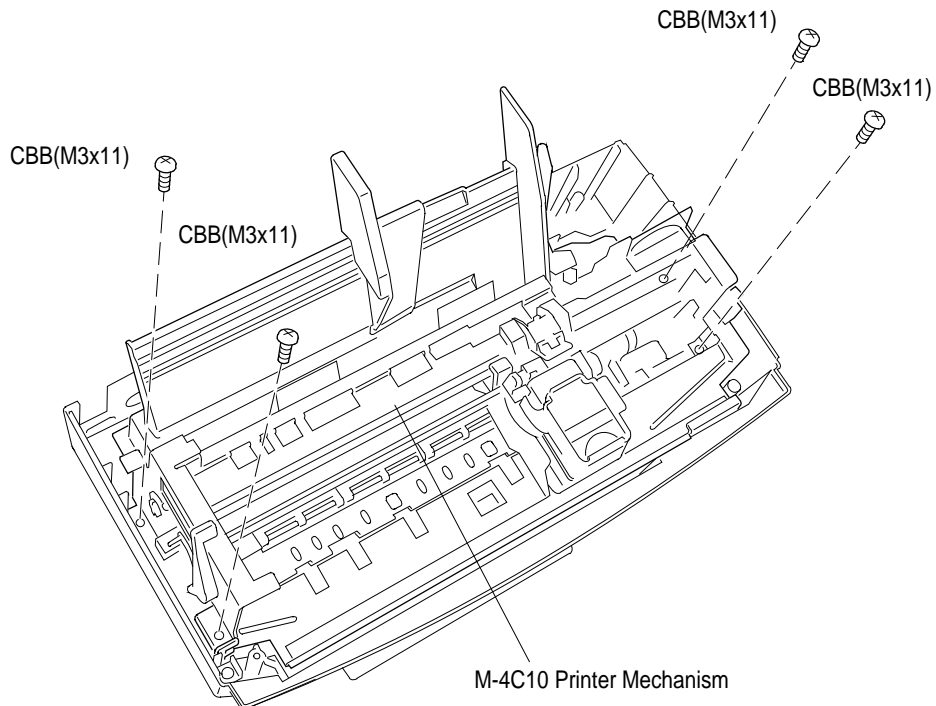
Figure 3-6. C160 PSB/PSE Board Removal

### 3.2.5 M-4C10 Printer Mechanism Removal

1. Remove the upper case (see Section 3.2.1).
2. Remove the C160 MAIN Board (see Section 3.2.2).
3. Remove the C160 I/F Board (see Section 3.2.3).
4. Remove the C160 power supply board (see Section 3.2.4).
5. Remove 4 CBB (M4x11) screws securing the printer mechanism to the lower case.

#### **CAUTION**

*When you replace the printer mechanism, perform the required adjustments. (See Chapter 4.)*



**Figure 3-7. Printer Mechanism Removal**

### 3.2.6 Printer Mechanism Disassembly

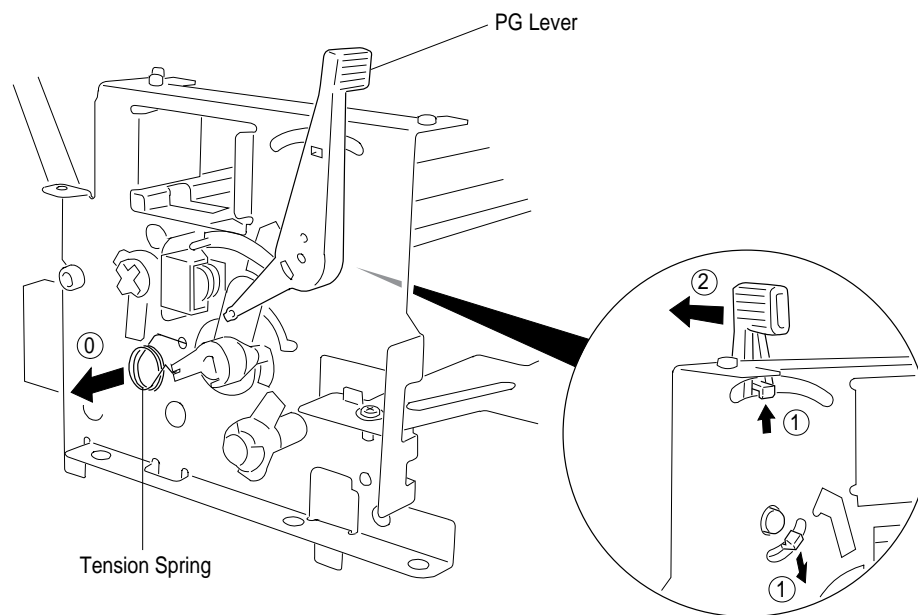
The procedures described in this section explain how to remove components within the printer mechanism.

#### 3.2.6.1 Carriage Unit Removal

1. Remove the printer mechanism (see Section 3.2.6).
2. Remove the blue PG lever.
3. Remove the tension coil securing the parallelism bushing to the side frame.

#### **CAUTION**

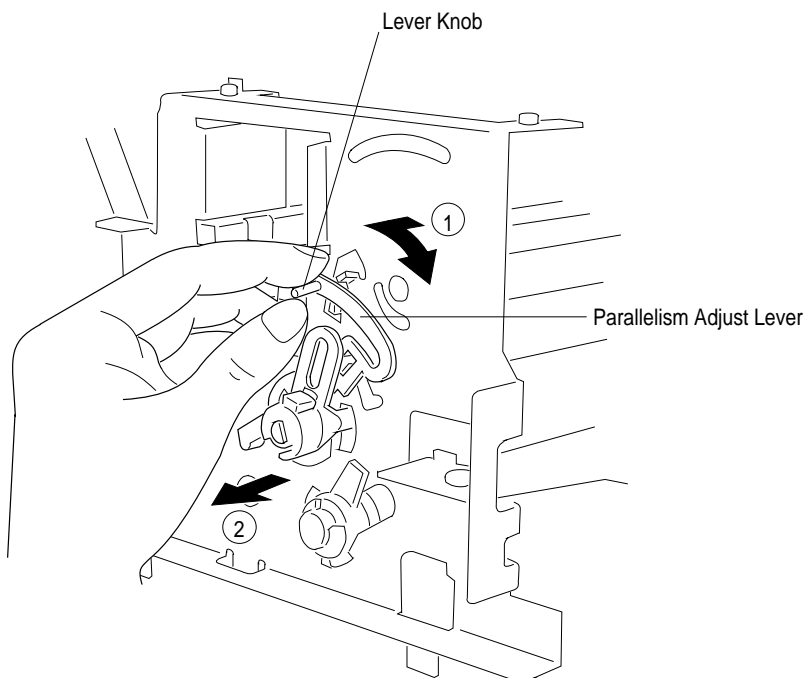
*Use only O9 oil when lubricating the carriage guide shaft.*



**Figure 3-8. PG Lever and Tension Coil Removal**

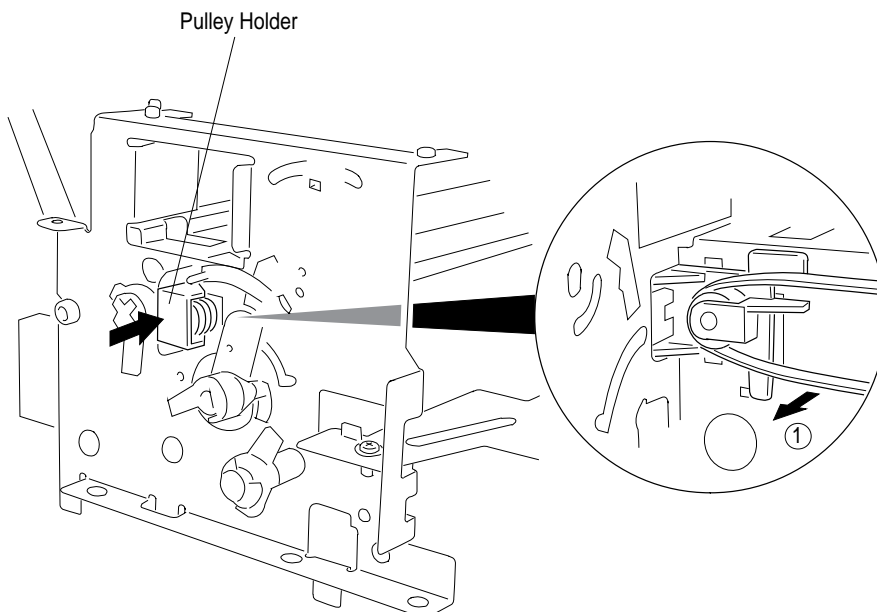


- 4. Remove the parallelism adjust lever by rotating it toward front while pulling the lever knob.



**Figure 3-9. Parallelism Adjust Lever Removal**

- 5. Remove the timing belt while pressing the pulley holder; then remove the carriage unit along with the carriage guide shaft.



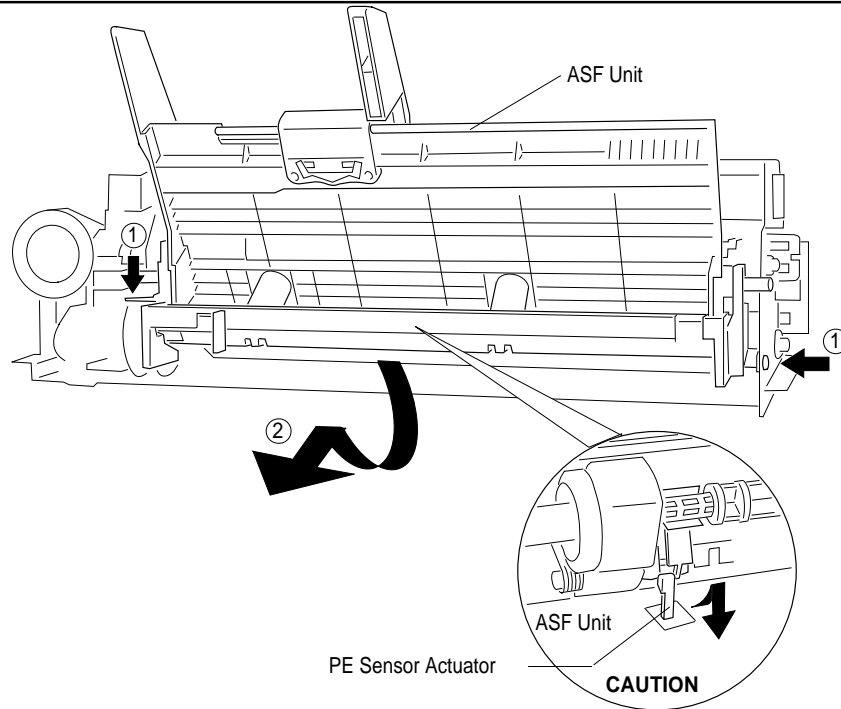
**Figure 3-10. Carriage Unit Removal**

### 3.2.6.2 ASF Unit Removal

1. Remove the printer mechanism (see Section 3.2.5).
2. Press down the tab on the left side; then pull the ASF unit toward you.
3. Press the tab on the right side; then remove the ASF unit.

#### CAUTION

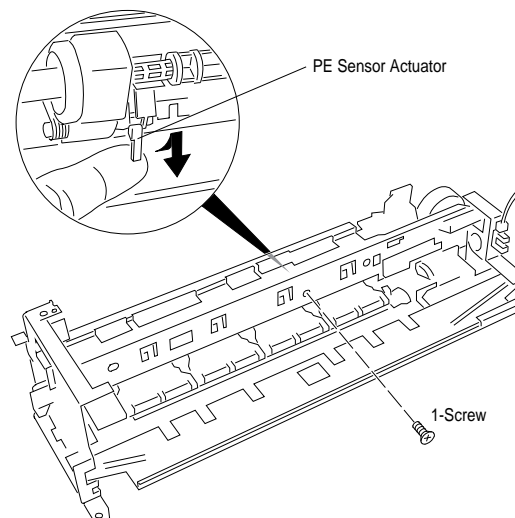
*When you remove the ASF, be extremely careful of the PE sensor. Pull the top of the ASF unit toward the front of the mechanism to clear the PE sensor.*



**Figure 3-11. ASF Unit Removal**

### 3.2.6.3 PE Sensor Removal

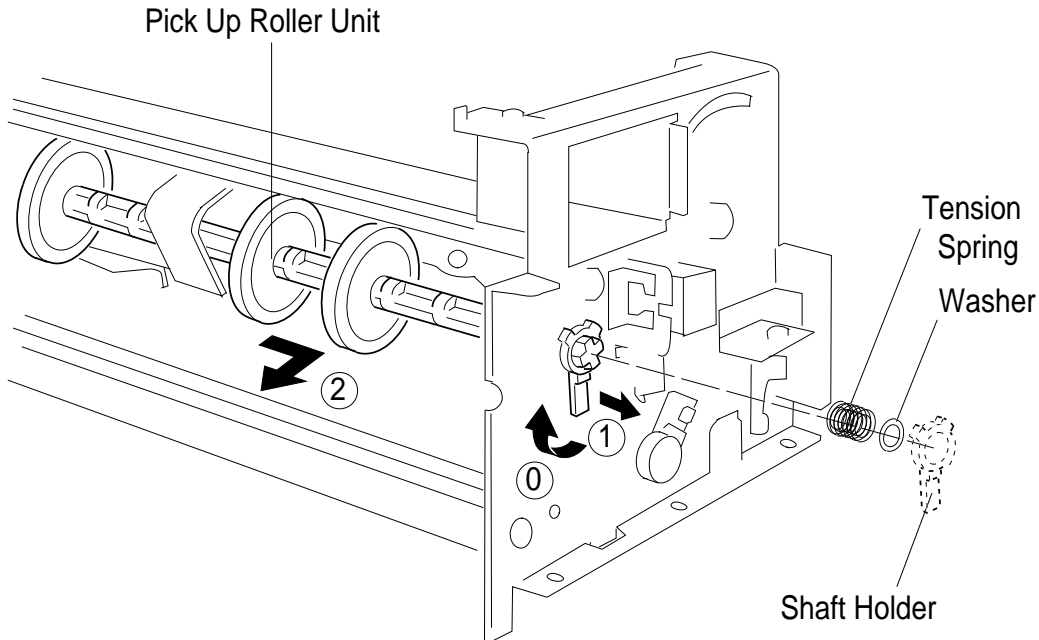
1. Remove the printer mechanism (see Section 3.2.5).
2. Remove the ASF unit (see Section 3.2.6.2).
3. Disconnect CN7 on the C160 MAIN Board, then remove the PE sensor.



**Figure 3-12. PE Sensor Removal**

### 3.2.6.4 Pickup Roller Unit Removal

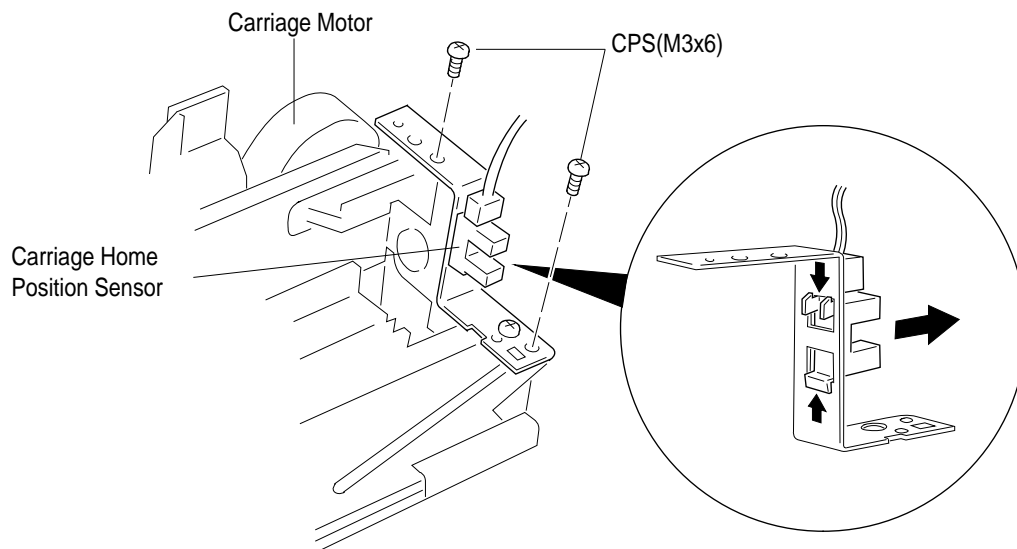
1. Remove the printer mechanism (see Section 3.2.5).
2. Remove the ASF unit (see Section 3.2.6.2).
3. Remove the PE sensor (see Section 3.2.6.3).
4. By rotating it, remove 1 shaft holder securing the roller shaft to the frame.
5. Remove the pickup roller unit, referring the following illustration.



**Figure 3-13. Pick Up Roller Unit Removal**

### 3.2.6.5 Carriage Home Position Sensor Removal

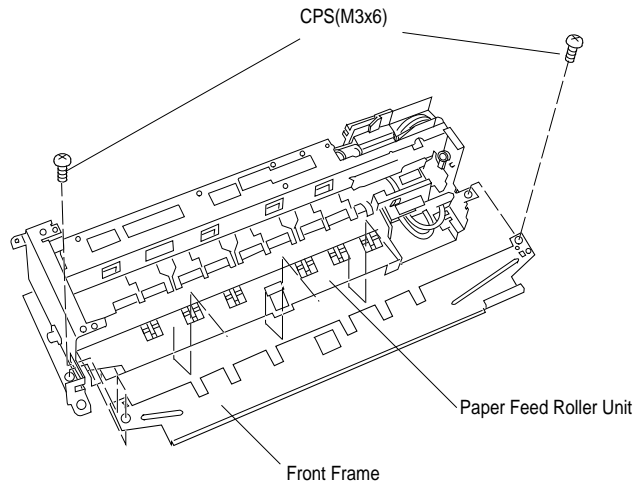
1. Remove the printer mechanism (see Section 3.2.5).
2. Disconnect the CN8 on the C160 MAIN Board.
3. Remove the 2 CPS (M3x6) screws securing the metal stay to the printer mechanism.



**Figure 3-14. Carriage Home Position Sensor Removal**

### 3.2.6.6 Paper Feed Roller Unit Removal

1. Remove the printer mechanism (see Section 3.2.5).
2. Remove the carriage unit (see Section 3.2.6.1).
3. Remove the carriage home position sensor (see Section 3.2.6.5).
4. Remove the tension spring holding the tension roller assembly to the sub frame.
5. Remove 2 CPS (M3x6) screws securing the front frame to the printer mechanism.
6. Remove the paper feed roller unit.



**Figure 3-15. Paper Feed Roller Unit Removal**

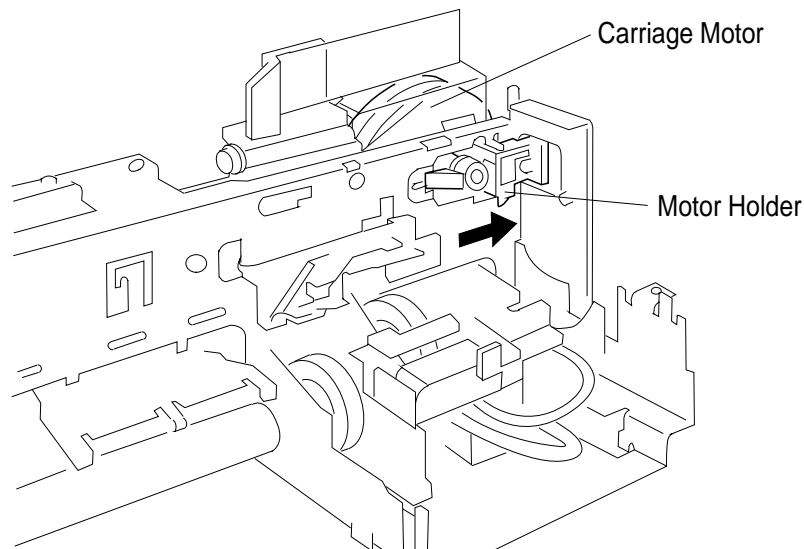
### 3.2.6.7 Carriage Motor Removal

1. Remove the printer mechanism (see Section 3.2.5).
2. Remove the carriage unit (see Section 3.2.6.1).
3. Remove the carriage (CR) motor.

**Note:** When you remove the CR motor, be sure to keep the washer on the CR motor gear.

#### **CAUTION**

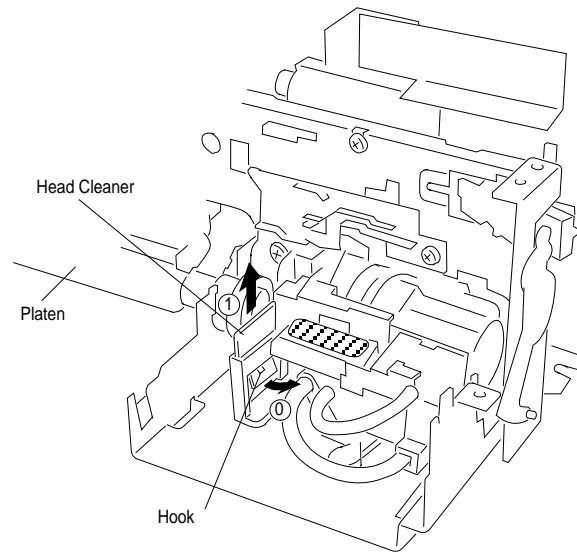
*When you remove or remount the CR motor, be careful of the post at both the top and bottom of the motor. If this post is broken, the motor will not seat correctly and can move during printing.*



**Figure 3-16. Carriage Motor Removal**

### 3.2.6.8 Head Cleaner Replacement

1. Remove the printer mechanism (see Section 3.2.5).
2. Remove the front frame (see Section 3.2.6.6).
3. Use tweezers to unhook the head cleaner.



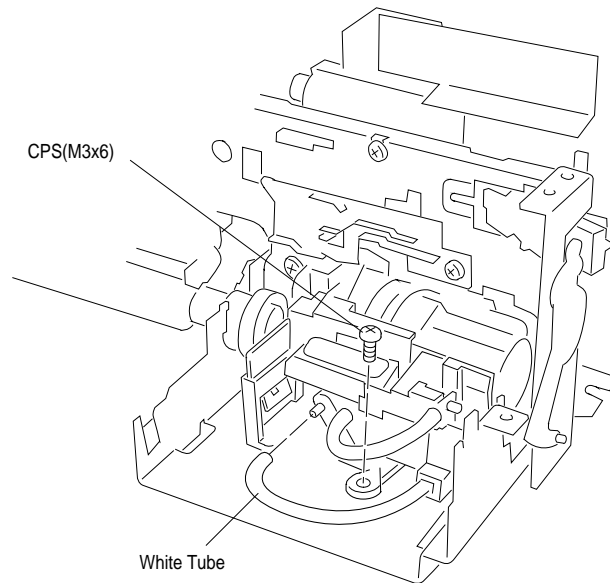
**Figure 3-17. Head Cleaner Replacement**

#### **CAUTION**

- o *Never touch the head cleaner with your bare hands.*
- o *When attaching the head cleaner, wear gloves and use clean tweezers to handle it.*

### 3.2.6.9 Cap Unit Removal

1. Remove the printer mechanism (see Section 3.2.5).
2. Remove the front frame (see Section 3.2.6.6).
3. Remove 1 CPS (M3x6) screw securing the cap unit to the lower frame.

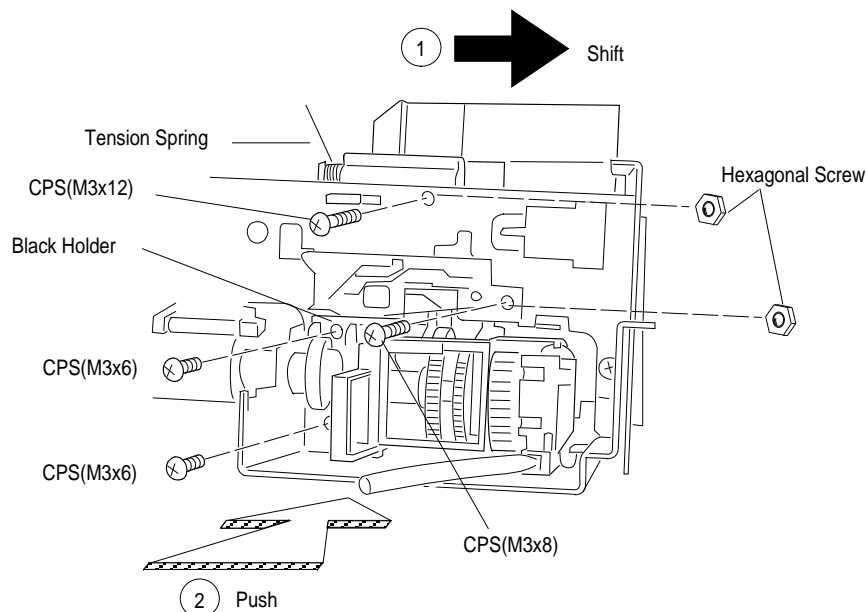


**Figure 3-18. Pump Unit Removal**

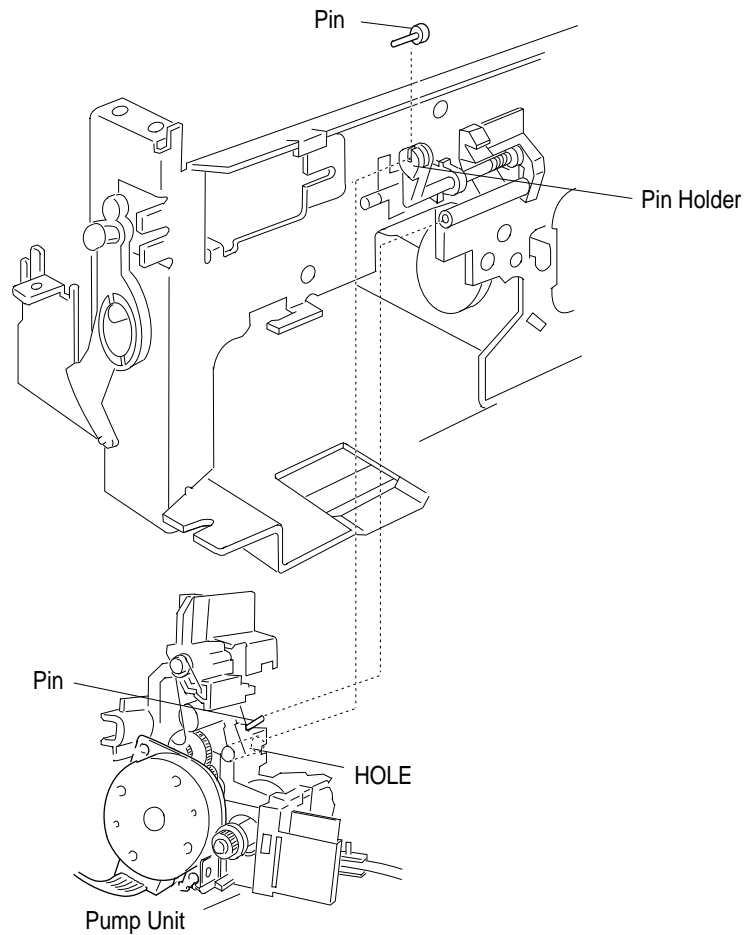
4. Remove 1 CPS (M3x6) screw securing the black holder to the frame
5. Remove the white tube connecting the cap unit to the pump unit. (Be careful an ink leak when you remove this ink tube.)
6. Remove 3 screws — 1 CPS (M3x6), 1 CPS (M3x12), and 1 CPS (M3x8) — securing the pump unit to the main frame.
7. Release a tension spring securing the paper pick up trigger holder to the pump mechanism.

**Notes:**

1. When you remove the pump unit, be sure to keep the washer, located behind the pump.
2. When you remove the pump unit, do not lose the pin in the pin holder.



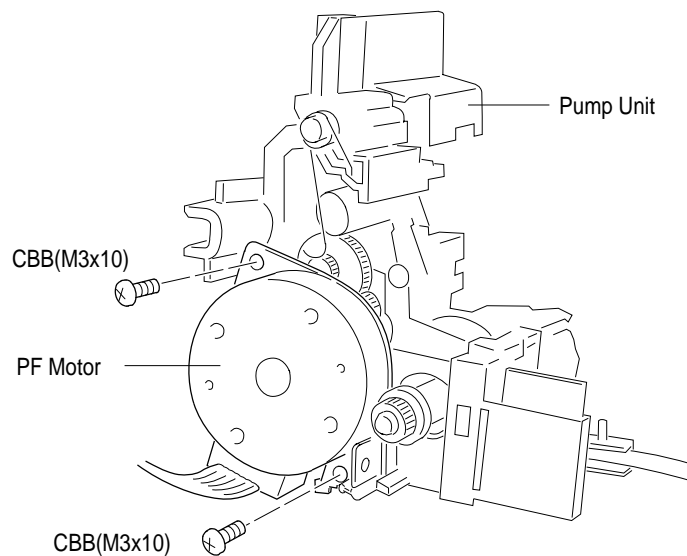
**Figure 3-19. Pump Unit Releasing**



**Figure 3-20. Pin Position**

### 3.2.6.10 Paper Feed Motor Removal

1. Remove the printer mechanism (see Section 3.2.5).
2. Remove the pump unit. (see Section 3.2.6.9).
3. Remove the 2 CBB (M3x10) screws securing the paper feed motor to the motor frame.



**Figure 3-21. Paper Feed Motor Removal**

# Chapter 4 Adjustment

---

## Table of Contents

<b>4.1 OVERVIEW</b>	<b>4-1</b>
4.1.1 Destination Data Writing Operation	4-2
4.1.2 Bi-D (Bidirectional Printing) Alignment Adjustment	4-3
4.1.3 Head Angle Adjustment (Black Head only)	4-5
4.1.4 Platen Gap Adjustment	4-7
4.1.5 EEPROM Reset Operation	4-8

### List of Figures

Figure 4-1. Nozzle Confirmation Pattern	4-3
Figure 4-2. Head Angle Pattern (Angle Correct)	4-5
Figure 4-3. Head Angle Pattern (Angle Incorrect)	4-5
Figure 4-4. Angle Lever Operation	4-6
Figure 4-5. PG Lever Operation	4-7
Figure 4-6. Confirmation Method	4-7

### List of Tables

Table 4-1. Required Adjustments	4-1
Table 4-2. Gap and Adjustment Direction	4-2

## 4.1 OVERVIEW

This section describes adjustments required when the printer is disassembled and assembled after repair.

### **WARNING**

oAfter removing an ink cartridge, always install a new cartridge immediately. During adjustments and testing, use cartridges designed exclusively for service (Monochrome: 1023206, CMY: 1023207).

oOnly adjust the black head angle when you perform the head angle adjustment.

**Table 4-1. Required Adjustments**

Service Performed	Adjustment Needed
When replacing the M-4C10 Printer Mechanism	1. Bi-D Adjustment (see Section 4.1.2).
When replacing C160 MAIN Board	1. EEPROM Reset Operation (see Section 4.1.5). 2. Destination Data Registration (see Section 4.1.1). 2. Bi-D Alignment Adjustment (see Section 4.1.2).
When replacing or disassembling the carriage unit	1. Head Angle Adjustment (see Section 4.1.3). 2. Platen Gap Adjustment (see Section 4.1.4).

### 4.1.1 Destination Data Writing Operation

The setup value that specifies the printer destination (for character generation and panel default settings) is stored in the EEPROM on the C160 MAIN Board. Therefore, this setup value must be written into the EEPROM when the main board or EEPROM chip is replaced.

#### **CAUTION**

*Before writing the destination data writing, set the interface to parallel.*

1. Connect the PC to the target printer using a parallel interface cable and turn the printer on.
2. Execute BASIC on the PC, and run the program HUDSON.BAS. You see the following menu:

```
Stylus / MJ Program H90E00E
**** Model ****
1. Stylus Color IIs
2. Stylus 820
3. MJ-500C
7. END
```

3. When the main menu appears, choose the product name by typing **1** or **2** and **Enter**.
4. You see the following menu.

```
Stylus / MJ Program H90E00E
**** Customer ****
1. EAI, EAI (Latin America), EAL, ESP, ETT
2. EUL, EDG, EFS, EIS, EIB, EUL (North Europe), EUL (Middle East), EHK
3. [EDG (NLSP)]
4. Russia

Slect Menu ?
```

5. Select your country.
6. If you have completed all your selections, turn off the printer.

**Note:** It is not necessary to turn off the printer if you want to perform the other adjustments.

### 4.1.2 Bi-D (Bidirectional Printing) Alignment Adjustment

Bidirectional alignment is required when the printer mechanism, main board, or printhead (board) is replaced. Performing this adjustment determines a compensation value to rectify any deviation in the print position. This deviation could be caused by the different print speeds, which are due to tolerances in the mechanical components, or to differences in print timing between odd-numbered lines and even-numbered lines in bidirectional printing. The printer stores the compensation data in the EEPROM on the C160 MAIN Board and refers to this data when performing bidirectional printing.

1. Perform steps 1 to 5 in Section 4.1.1. Then you see the following menu:

```

Stylus Program * H90E00E
Model      : Stylus Color IIs
Customer   : EAI, EAI (Latin America), EAL, ESP, ETT

1. Ink discharge (Black)
2. Ink discharge (Color)

3. Head Angle Adjustment
4. Bi-D Adjustment (Bi-d Center -15)

5. A4 check pattern (Black)
6. A4 check pattern (Color)
7. Envelope
8. Index Card / Post Card

0. Change Customer & Model / END

13. BLACK Ink Counter Reset
14. COLOR Ink Counter Reset

Select Menu      ?
  
```

2. Choose “Bi-D Adjustment” by typing 4 and **ENTER**. You see the following menu:

```

                BLACK head  —— 1
                COLOR head  —— 2

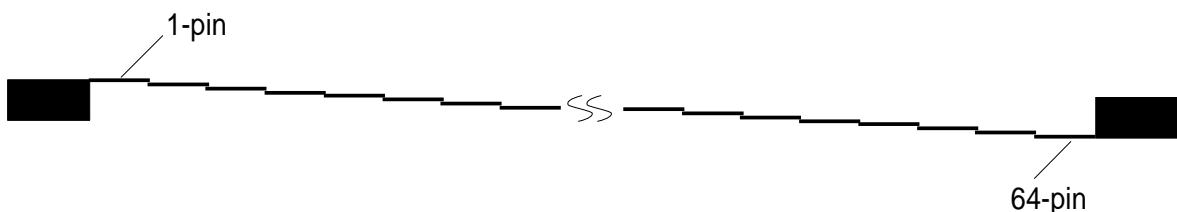
Select Menu ?
  
```

3. Choose the type of head currently installed on the main unit. The printer prints the Bi-D pattern with the current value. (The next value will automatically appear.) Also, the display will change as shown below:

```

INPUT ADJUST NO. (IF OK INPUT Y & RETURN) ?
ADJUST RANGE (from -36 to 36)
  
```

**Note:** You also can find any clogged nozzle by printing the sample pattern below.



**Figure 4-1. Nozzle Configuration Pattern**



4. If the sample print does not vertically align both odd- and even-numbered lines, enter a compensation value in the range from  $-36$  to  $+36$ .
  - o Positive compensation value: Shifts the 2nd line to the left
  - o Negative compensation value: Shifts the 2nd line to the rightWhen the sample print becomes vertically aligned for both lines, press **Y** and **ENTER**; this returns you to the main menu.
6. Choose "END" by typing **0** and **ENTER**. The initial message appears on the display. If you have completed all the adjustments you want to make, turn off the printer.

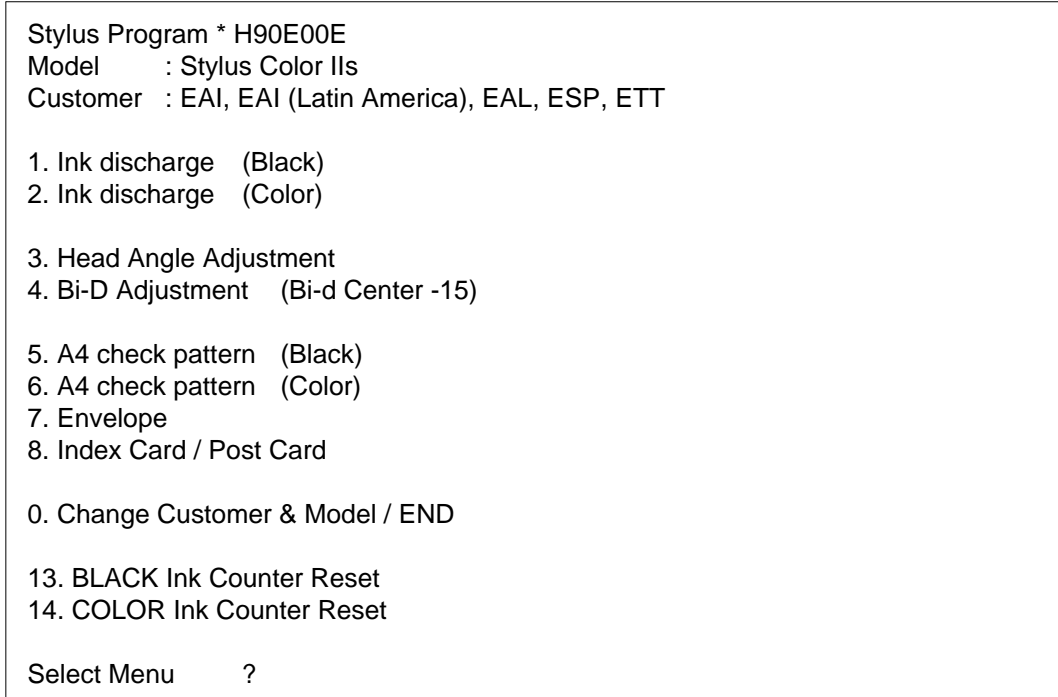
**Note:** It is not necessary to turn off the printer if you want to perform the other adjustments.

### 4.1.3 Head Gap Adjustment (Black and Color Head)

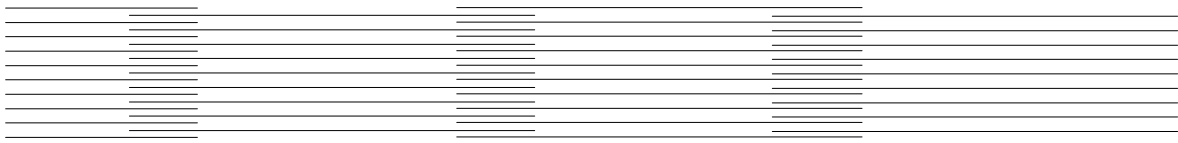
The head gap adjustment is required when the printer mechanism, main board, or printhead (board) is replaced or disassembled. This adjustment calibrates the head drive timing between the black and color head. If this adjustment is not made, the vertical alignment will not be completed.

**Note:** Use only a black head unit when you perform the head angle adjustment. Also, use only a normal plain paper, because the type of black ink is using the slow penetration type.

1. Perform steps 1 to 5 in Section 4.1.1. Then you see the following menu:

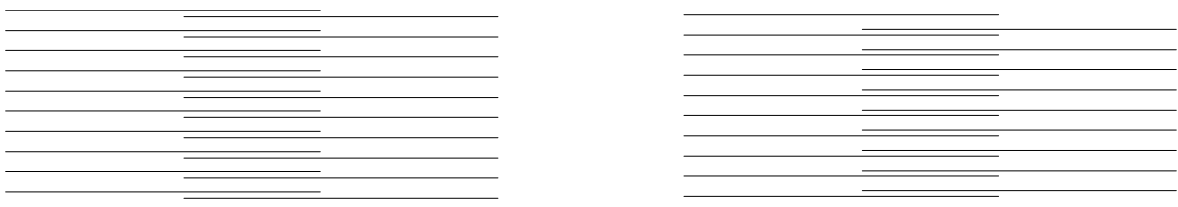


2. Choose “Head Angle Adjustment” by typing **3** and **ENTER**. Then the printer prints an angle adjustment check pattern. If the head angle is correct you see the following angle adjustment pattern.



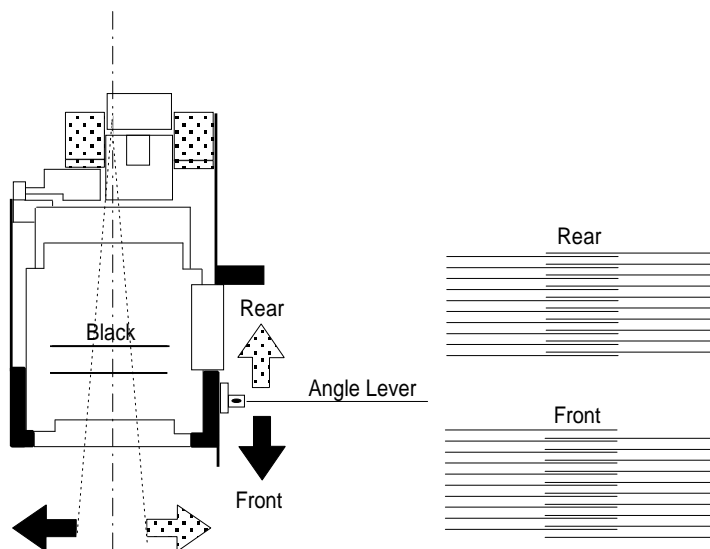
**Figure 4-2. Head Angle Pattern (Angle Correct)**

3. If the angle adjustment is incorrect, you see a pattern similar to the one below. If this is the case, go to step 4.



**Figure 4-3. Head Angle Pattern (Angle Incorrect)**

4. Change the angle lever, referring to the description below.



**Figure 4-4. Angle Lever Operation**

**Note:** You can change the angle lever without removing the upper case.

5. To confirm the head angle, then press the space key to print the modified pattern. If you want to continue adjusting the head angle, press the space key after you change the angle lever. When the head angle becomes correct, press the **Y** key to return to main menu.

### 4.1.4 Platen Gap Adjustment

This adjustment is required when the carriage unit is removed from the main unit or replaced. Adjust the distance between the printhead nose and the paper surface to 1.18 mm.

1. Remove the upper case, and place a thickness gauge (commercially available) on the paper guide plate at the adjustment position on the left side of the printer, as shown in the figure below:
2. Move the carriage unit manually onto the thickness gauge.

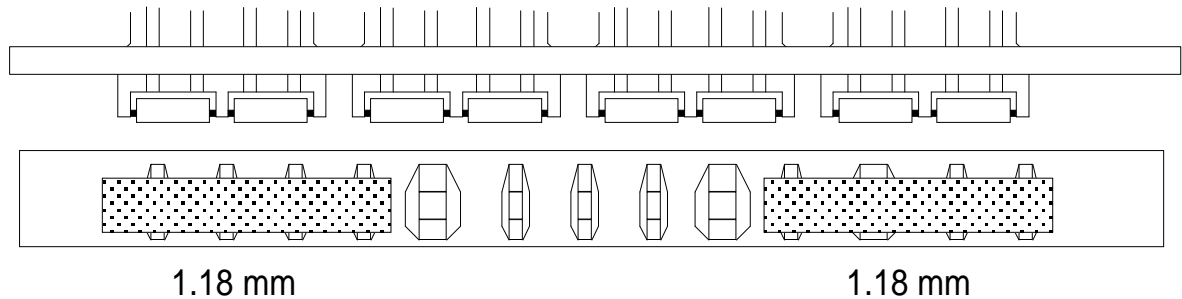


Figure 4-5. PG Lever Operation

Table 4-1. Gap and Adjustment Direction

Gap between Head Nose and Gauge Surface	Move Left Bushing	Move Right Bushing
Too narrow	Clockwise (CW)	Counterclockwise (CCW)
Too wide	Counterclockwise (CCW)	Clockwise (CW)

3. Rotate the parallelism adjustment bushing, attached to the left and right ends of the carriage guide shaft until the black or color printhead contacts the thickness gauge.
4. After placing the printheads against the gauge surface, verify the gap between the carriage flag and the front frame. (See Figure 4-6.)

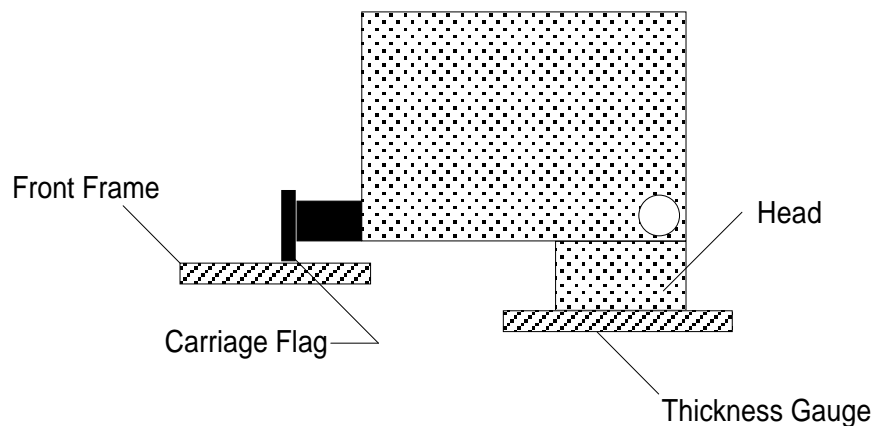


Figure 4-6. Confirmation Method

### 4.1.5 EEPROM Reset Procedure

This operation is required when the C160 MAIN Board is replaced, when the waste ink drain pad is replaced, or to recover from printer malfunction. There are two reset methods for this printer. (Reset All and Reset Maintenance Error Only)

#### Reset All

1. Turn printer power on while pressing the ALT and Load / Eject buttons.
2. Hold down the Load / Eject button for 10 seconds.

*Note:* The Pause and Economy LEDs start to blink when printer accepts the reset mode. If the Pause and Economy LEDs do not start to blink, return to step 1.

3. Press the Pause button. Then printer starts initialization automatically.

#### Reset Maintenance Error Only

1. Turn printer power on while pressing the ALT and Load / Eject buttons.
2. Hold down the Load / Eject button for 10 seconds.

*Note:* The Pause and Economy LEDs start to blink when printer accepts the reset mode. If the Pause and Economy LEDs do not start to blink, return to step 1.

3. Press the Alt button. Then printer starts initialization automatically.

# Chapter 5 Troubleshooting

---

## Table of Contents

<b>5.1 OVERVIEW</b>	<b>5-1</b>
<b>5.2 Repair the Power Supply Board</b>	<b>5-3</b>
<b>5.3 Repair the C160 Main Board</b>	<b>5-4</b>
<b>5.4 Repair of PRINTER MECHANISM (M-4C10)</b>	<b>5-6</b>

---

## LIST OF FIGURES

<b>Figure 5-1. Troubleshooting Construction</b>	<b>5-1</b>
<b>Figure 5-2. Main Flow-Chart for Recover a Dot-missing</b>	<b>5-8</b>
<b>Figure 5-3. 360-DPI Check Pattern</b>	<b>5-10</b>
<b>Figure 5-4. Standard of Dot-missing</b>	<b>5-10</b>
<b>Figure 5-5. The Bent part on the Cap Rubber</b>	<b>5-11</b>

## LIST OF TABLES

<b>Table 5-1. Motor Resistance</b>	<b>5-1</b>
<b>Table 5-2. Sensor Status</b>	<b>5-2</b>
<b>Table 5-3. Repair of the C160 PSB/PSE</b>	<b>5-2</b>
<b>Table 5-4. Repair of the C160 Main</b>	<b>5-3</b>
<b>Table 5-5. Repair of the Printer Mechanism</b>	<b>5-4</b>
<b>Table 5-6. Ink Cartridge Exclusive for the Service Side</b>	<b>5-7</b>
<b>Table 5-7. Repair of the Printer Mechanism</b>	<b>5-12</b>

## 5.1 OVERVIEW

This section describes troubleshooting at the unit level and for abnormal printing(missing-aligned dots). The EPSON Stylus Color IIs/Stylus 820 uses a new print head that is different than the previous Stylus Color print head. Because of its designs, indicating that the cartridge is low or out of ink. If you remove or even partially remove a cartridge unit before it is out of ink, air invades the print head nozzle(s) and the ink cartridge. Once air bubbles clog the nozzle(s), they are very difficult to eliminate. Refer to Section 5.5 to attempt to clear clogged nozzle(s).

### Caution

*The ink out sensor on the printer is monitored by the firmware counter. If you replace an ink cartridge before it ink sensor is activated, you must clear the EEPROM first.*

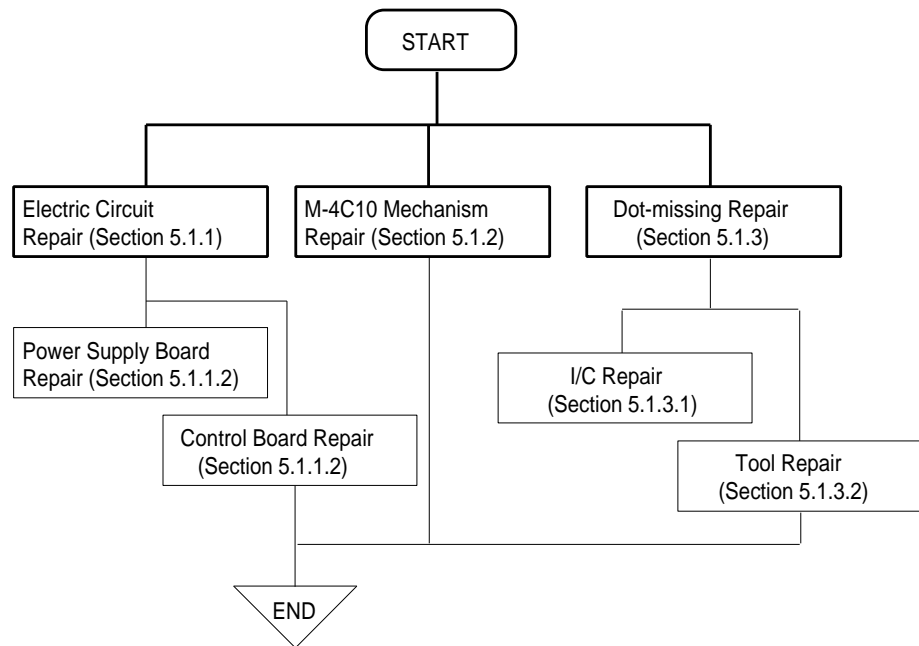


Figure 5-1. Trouble Shooting Construction

Table 5-1. Motor Resistances

Motor	Resistance Range	Temperature
CR Motor	22 Ω ± 7%	At 25 °C (77 °F)
PF Motor	21 Ω ± 1 Ω	At 25 °C (77 °F)



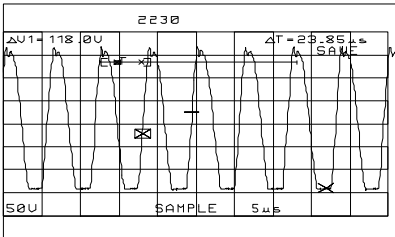
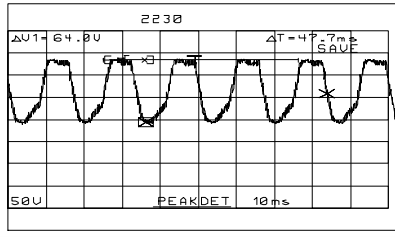
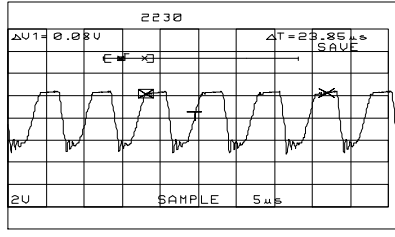
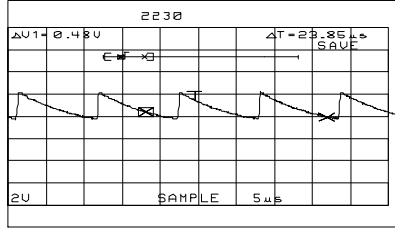
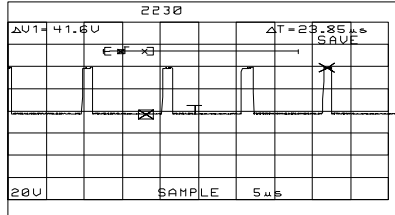
**Table 5-2. Sensor Status**

Sensor	Point	Signal Level	Status
PE Sensor	CN7 Pin 1 (PE) to Pin 2 (GND)	H (5 V)	Paper exists
		L (GND)	No paper (paper end)
CO Sensor	CN4 Pin 3 (CO) to Pin 8 (GND)	L (GND)	Cartridge exists
		H (5 V)	No cartridge
M/C Sensor	CN4 Pin 19 (M/C) to Pin 8 (GND)	L (GND)	Color cartridge exists
		H (5 V)	Black cartridge exists
HP Sensor	CN8 Pin 1 (HP) to Pin 2 (GND)	L	At home position (HP)
		H	Out of HP
ID1 - ID4	CN4 Pin10,15,16,17 (ID1,2,3,4) to Pin 2 (GND)	4-bit combination	Program ROM decides the proper voltage in the firmwear table. (15-pattern)
ASF Sensor	CN9 Pin 1 (ASF) to Pin 2(GND)	L	Manual feed mode
		H	Auto feed mode

## 5.2 Unit-Repair - C160 Power Supply Board

This section describes how to repair the C160 power supply board and main board. The table below provides various symptoms, likely causes, and check points. The checkpoints refer to waveforms, resistances, and other values to check to evaluate the operation of each component.

**Table5-3. Repair of the C160 PSB / PSE**

Sympton	Condition	Cause	Checkpoints	Solution
Printer does not operate at all.	+35V line is dead.	F1 is open.	Check the F1.	Replace F1.
		T1 is open.	Check T1 coils using the tester.	Replace T1.
		Q1 is broken.	Check the wave-form at the drain of Q1. 	Replace Q1.
		Q2 or Q3 is broken.	Check the wave-form at the drain of Q2 and Q3. 	Replace Q2 or Q3.
		PC1 is broken.	Check the wave-form at 3-pin of PC1. 	Replace PC1.
	+5V is dead.	L4962 is broken.	Check the oscillation at 5-pin of IC51. 	Replace IC51.
			Check the output wave-form at 7-pin of IC51. 	Replace IC51.

### 5.3 Unit Repair - C160 Main Control Board

This section describes the problems related to the main controller board (C160 MAIN). The table below provides various symptoms, likely causes, and checkpoints. The checkpoints refer to waveforms, resistance, and other values to be checked to evaluate the operation of each component.

**Table 5-4. Repair of C160 MAIN**

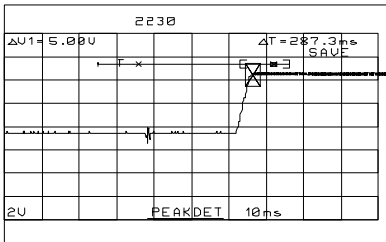
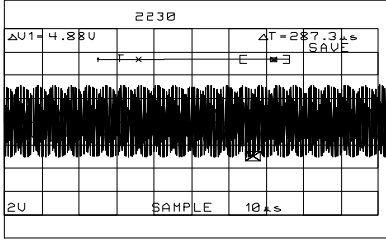
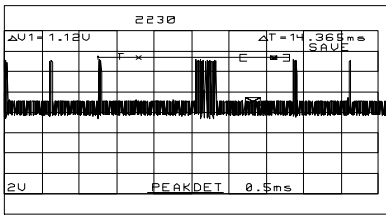
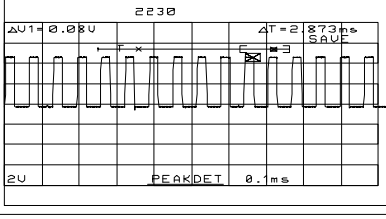
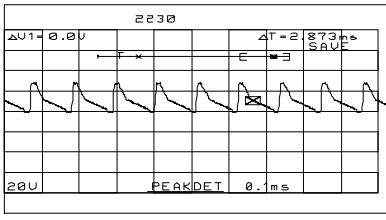
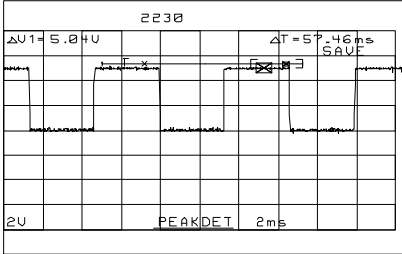
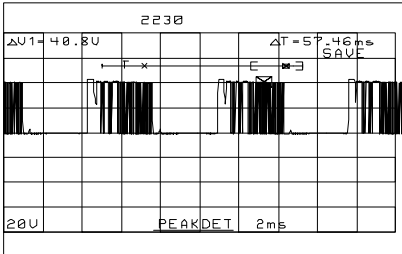
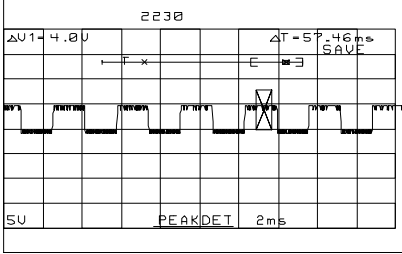
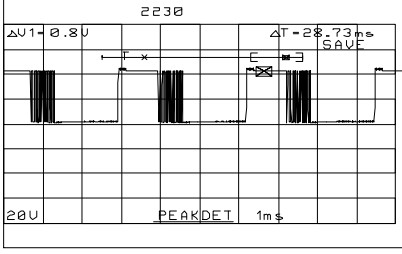
Phenomenon	Condition	Cause	Checkpoints	Solution
It does not operate at all.	CPU does not operate.	Reset circuit does not operate.	Check the wave-form at either pin 1 and 4(GND). 	Replace IC13.
		CRU1 or IC2 is defective.	Does wave-form of CRU1 is correct? (at either pin 37 and 38 of CPU) 	Correct : replace IC2. Incorrect : replace CRU1.
	Gate array does not operate.	CRU2 or IC1 is defective.	Does wave-form of CRU2 is correct? (Refer to above wave-form.)	Correct : replace IC1. Incorrect : replace CRU2.
		OE signal does not output.	Check the wave-form at the pin (52,54,56,57,58). 	Replace IC1.
Self-test printing does not abnormal.	Gate array does not operate.	PWM signal does not output.	Does PWM wave-form is correct? (Check the pin at 140.) 	Replace IC1.
	Common driver circuit does not operate.	Tr does not operate.	Check the wave-form at the pin 3 of QM3. 	Replace a defective element.(QM1,2,3,4, 5,6,7,8 or Q1,7,8.)



Table 5-4. Repair of C160 MAIN(Cont.)

Phenomenon	Condition	Cause	Checkpoints	Solution
Carriage does not operate normally.	Drive pulse does not output.	CPU is defective.	Does the wave-form correct? (Check pin either at 9 and 10.) 	Replace CPU.
		IC12 is defective.	Does the wave-form correct? (Check pin at 17,20 and 14,23.) 	Correct : replace motor. Incorrect : repalce IC12.
PF motor does not operate normally.	Drive pulse does not output.	CPU is defective.	Does the wave-form correct? (Check pin either at 3 and 4.) 	Replace CPU.
		IC16 is defective.	Does the wave-form correct? (Check pin at 17,20 and 14,23.) 	Correct : replace motor. Incorrect : repalce IC12.

## 5.4 Repair of PRINTER MECHANISM (M-4C10)

Any problems related to the printer mechanism should be repaired according to the troubleshooting procedures in Table 5-7.

**Table 5-5. Repair of the Printer Mechanism**

Symptom	Condition	Cause	Checkpoint	Solution
The pump mechanism does not operate.	The PF motor fails to rotate at power on.	PF motor is defective.	Measure the coil resistance of the CR motor. 21 Ω ± 1Ω	Remove any foreign substance.
		Carriage flag is defective.	Check the flag on the back of the carriage unit.	Replace the carriage unit.
	Used ink does not go through the used ink tube during the cleaning operation.	The tube is not properly connected to the cap.	Check that the tube is properly connected to the cap.	Insert the tube properly.
		The ink tube is damaged.	Check the ink tube visually.	Replace the tube.
		The cap is defective.	Check for any defective part.	Replace the head cap.
		The pump is defective.	Replace the pump to see if this causes the ink to be absorbed normally.	Replace the pump unit.
The printhead is defective.	Replace the printhead to see if this causes the ink to be absorbed normally.	Replace the printhead.		
The carriage motor does not rotate.	The carriage motor fails to rotate at power on.	PG value is incorrect.	Check the PG value. (1.18 mm ± 1/100)	Remove any foreign substances.
		CRHP sensor is defective.	Check voltage reaction at pin 1 on CN8.	Replace CRHP.
		The carriage motor is defective.	Measure the coil resistance of the CR motor. 22 Ω ± 7%	Replace the carriage motor.
The carriage does not operate normally at power on (after the carriage has been manually centered prior to power on).	The carriage motor rotates, but the carriage does not move.	The pulley is defective.	Check for broken or worn pulley.	Replace the driven pulley.
		The timing belt is defective.	Check that the timing belt is properly inserted into the bottom of the carriage.	Reinsert the timing belt.
	The carriage moves slightly and then stops.		Carriage movement is not smooth.	Check the timing belt for any damage.
		Check whether the carriage moves smoothly when moved manually.		Clean and lubricate the carriage.
			Check tension of the timing belt.	Adjust tension of the timing belt.

## 5.5 Dot missing Trouble shooting Guide

This section describes how to recover the clogged nozzle when you receive the dot-missing printer. Since the print head of this printer is the new system, it is very difficult to eliminate the invaded air bubble from the print head unit or the ink cartridge so that, never use again if you remove once a ink cartridge from the main unit.

Also, we prepare the special ink cartridge exclusive for your service side. Please refer to the under table for low price ink cartridge.

**Table 5-6. Ink Cartridge exclusive for the service side**

Ink Cartridge	Code
Black ink cartridge	1023206
Color Ink cartridge	1023207

Note: Please read throughly under the cautions before you start to repair.

### **WARNING 1**

*Do not re-use a removed ink cartridge when you return the printer to your user.*

### **WARNING 2**

*Since the ink end sensor is counted by the firmwear counter, it is a possibility that the life of brand-new ink cartridge can not be guranteed if you reuse the removed ink cartridge so that, perform the EEPROM reset after replace the ink cartridge.*

### **WARNING 3**

*There are two reset methods for clear the EEPROM . Select a proper method referring the Section 4.1.5.*

### 5.5.1 How to recover the dot-missing with the brand-new ink cartridge

The under flow-chart shows the way of the recovering a clogged nozzle with the ink cartridge. The section that is indicated the out of each items shows the additional explanation when you want to help a detail contents.

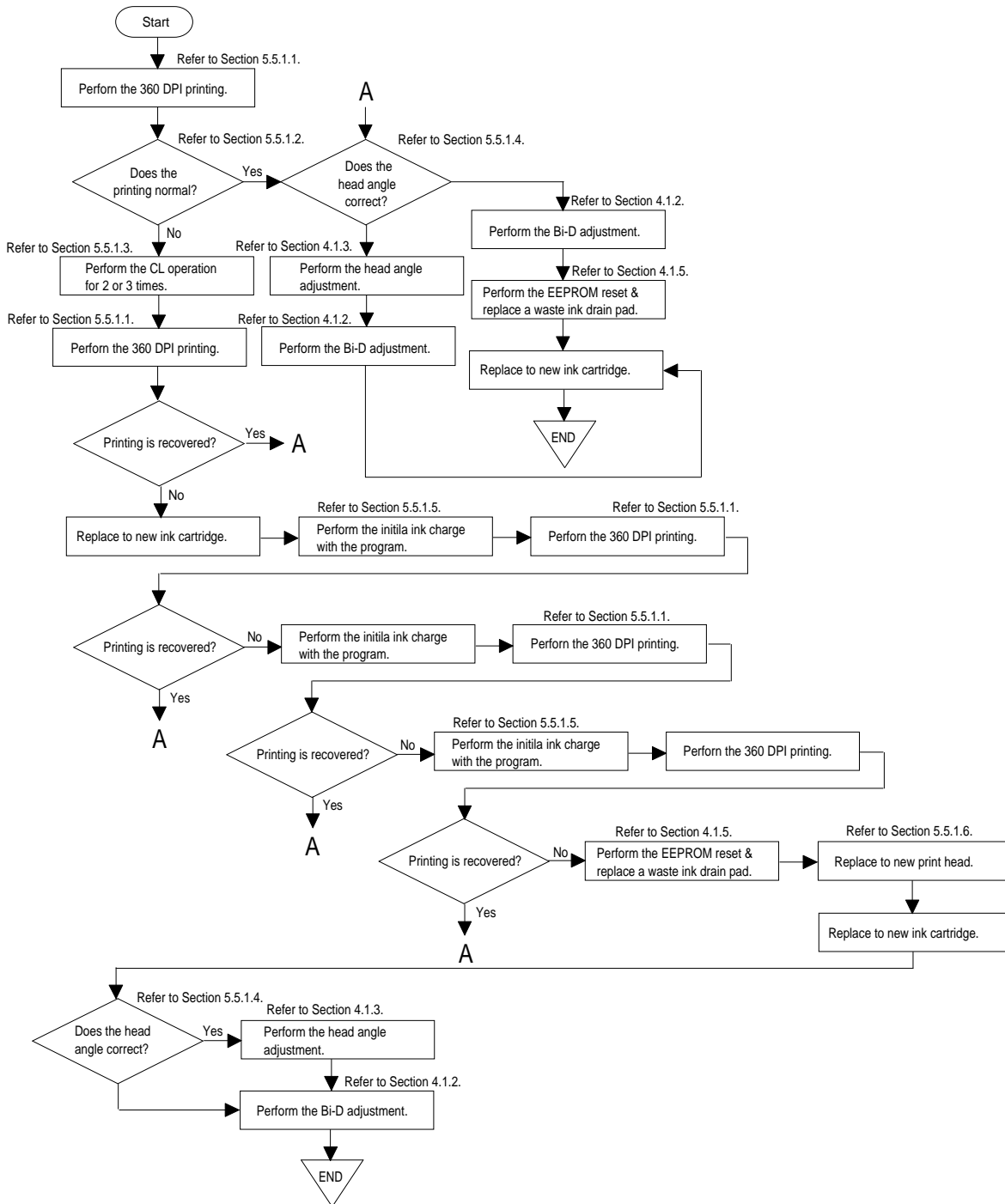


Figure 5-2. Main Flow-Chart for Recover a Dot-missing

### 5.5.1.1 How to Perform the 360-DPI Printing

It is possible to confirm the any problems with the 360-DPI check pattern printing. Also, if you receive the white banding problem, you can confirm the wrong condition quickly. Please perform the proper repair referring under explanations.

[Step 1] Connect the host computer to the printer with the printer cable.

[Step 2] Insert the paper to the hopper and load a paper.

[Step 3] Run the GWBASIC on the host computer, then execute the program. The file name is "HUDSON.BAS".

[Step 4] The initila menu will be appeared on the display.

```

STYLUS / MJ Program : H90E00E
**** Model ****
1. STYLUS COLOR IIs
2. STYLUS 820
3. MJ-500C
7. END
Select Menu ? "_ "

```

[Step 5] Select option 1 or 2 depending on the market. (**Never select option 3.**)

[Step 6] The next menu will be appeared on the display.

```

STYLUS / MJ Program : H90E00E
**** Customer ****
1. EAI, EAI (Latin America), EAL, ESP, ETT
2. EUL, EDG, EIS, EIB,EUL(North Europe), EUL (Middle EAST), EHK
3. [ EDG(NLSP) ]
4. Russia

Select Menu ? "_ "

```

[Step 7] Select your country number. you can register the CG table and the panel default set at this time. Then the adjustment menu will be appeared on the display.

```

STYLUS Program : H90E00E
Model : STYLUS COLORIIs(STYLUS 820)
Customer : EAI, EAI Latin, ——, etc.

1. Ink discharge (BLACK)
2. Ink discharge (COLOR)

3. Head Angular Adjustment
4. Bi-D Adjustment (Bi-D center -15)

5. A4 check pattern (BLACK)
6. A4 check pattern (COLOR)
7. Envelop
8. Index card/Post card

0. Change Customer & Model / END

13. BLACK Ink Counter Reset
14. COLOR Ink Counter Reset

Select Menu ? "_ "

```



- [Step 8] Select the option 5 or option 6 depending on your printer head. Then the display indicates the “MC No. ?”\_”
- [Step 9] Press the return key. Then the printer automatically prints a check pattern.  
First, the TOF line is printed, then the 360-DPI full duty pattern will be appeared.

2.BETA(With the black head)



3.BETA(With the color head)



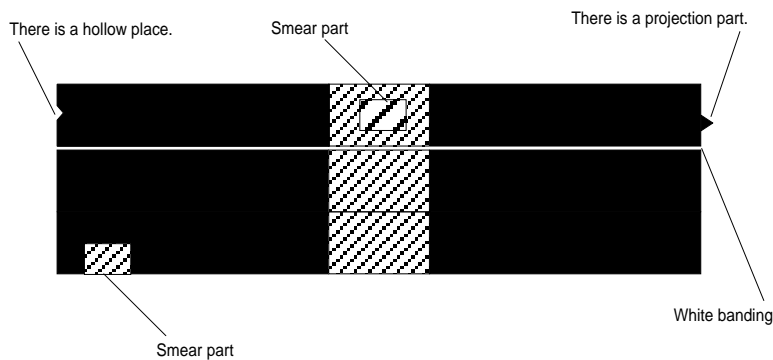
**Figure 5-3. 360-DPI Check Pattern**

Note: Select the correct value on the display because both pattern and color are different depending on the head units.

- [Step 10] We can imagine the miss-alignment or the dot-missing if the above pattern has a white banding or the smear part, so that advance to next step (Section 5.5.1.2) on the main flow-chart.

**5.5.1.2 Standard of “ Does the printing normal?”**

If the 360-DPI printing pattern has a under problem, advance to next step (Section 5.5.1.3)



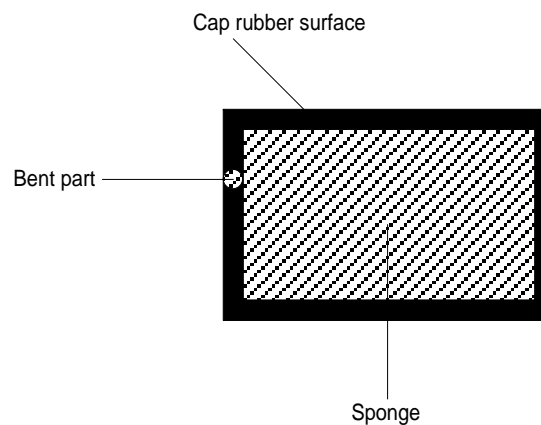
**Figure 5-4. Standard of Dot-missing**

### 5.5.1.3 Performing the CL operation for 2 ~ 3 times

This section describes the cleaning operation if you find a print missing on the 360-DPI check pattern. You need a confirmation either the CL operation is correctly performed or not in this function..

- [Step 1] Remove the upper case. (See the Section 3.2.1.)
- [Step 2] Perform the CL operation. (Under the pause state, pressing the Pause button while you pressing the Alt button.)
- [Step 3] Attention the waste ink drain tube either the ink is correctly supplied or not. If an ink is not correctly supplied, check the under items before you advance to next step on the main flow-chart.

Note:



**Figure 5-5. The Bent part on the Cap rubber**

*If you can not find a any problems about the pump unit system or the above contents, there is a possibility that an ink inside the ink cartridge has already emptied in spite of any counter values, so that it is necessary to replace to brand-new ink cartridge when you can not find any problems.*

*Also, if user perform the removing or installing with the same ink cartridge, it will not recover the dot-missing every time you perform the CL operation, because the constructure of the print head is very complexity as compair to previous head system. Therefore, replace to brand-new ink cartridge at this time.*

#### **5.5.1.4 Does the Head angle correct?**

This section describes either the head angle condition is correct or not. Refer to Section 4.1.3 in the actual adjustment.

[Step 1] Perform the head angle adjustment. (Refer to Section 4.1.3.)

Note: If the head angle condition is wrong, white or color banding problem will be appeared on the graphic pattern.

#### **5.5.1.5 Perform the initila ink charge with the program**

A clogged nozzle will be recovered with a large quantity of an ink by performing the initial ink charge operation.

[Step 1] Perform the Step 1 to Step 7 in the Section 5.5.1.1.

[Step 2] Press either the option 1 or option 2 depending on the print heads, then the next message (“Now Ink discharge”) appears on the display.

Note 1: Select a correct option with referring the current print head unit.

Note 2: There is a EEPROM all reset routine in the end of this option, so that, it is necessary to replace the waste ink drain pad if you perform this initial ink charge operation.

#### **5.5.1.6 Replace to new ink cartridge**

It is necessary to replace the print head unit if you can not recover a alogged nozzle by performing the initial ink charge, CL operation and replacing the new ink cartridge.

If you replace to new ink cartridge, do not re-use a removed ink cartridge again.

# Chapter 6 Maintenance

---

## Table of Contents

<b>6.1 PREVENTIVE MAINTENANCE</b>	<b>6-1</b>
6.1.1 Printhead Cleaning . . . . .	6-1
6.1.2 Waste Ink Drain Tank Replacement . . . . .	6-1
<b>6.2 LUBRICATION AND ADHESIVE</b>	<b>6-2</b>

---

### LIST OF FIGURES

Figure 6-1. Lubrication Points and Adhesive Points . . . . .	6-3
--	-----

### LIST OF TABLES

Table 6-1. Recommended Lubricants . . . . .	6-3
Table 6-2. Lubrication Points . . . . .	6-4
Table 6-3. Adhesive Points . . . . .	6-4

## 6.1 PREVENTIVE MAINTENANCE

This printer must be lubricated only **O9** when you need a lubrication for carriage guide shaft. If you lubricate with another oil, it could permanently damage the print head unit.

Although this printer requires no specific maintenance on a regular basis, recommends that you clean the following thoroughly whenever you get a chance.:

Outer case

Use a soft, clean cloth, dampened with mild detergent, if necessary.

Auto sheet feeder

If the inside of the auto sheet feeder is dirty (dusty), carefully brush away all dust and dirt using a soft brush. If the pickup roller of the sheet feeder is dirty, clean its surface with a soft, clean cloth.

Inside the printer

If you notice any dust or dirt that has accumulated inside the printer when you open the outer case for repair, remove all dust and dirt using a small vacuum cleaner designed for such purposes.

### **Warning**

- Use only O9 oil when lubricating the carriage guide shaft. If you lubricate with another oil, it could permanently damage the print head unit.*
- Never use paint thinner, trichloroethylene, or ketone-based solvents for cleaning. These chemicals can damage the components the printer.*
- Do not use a hard or abrasive brush for cleaning.*
- Be careful not to damage the components of the printer when using a vacuum cleaner.*

### 6.1.1 Printhead Cleaning

If print quality deteriorates, clean the printhead using the built-in printhead cleaning function. The printer also has an automatic printhead cleaning cycle to ensure proper nozzle operation for ink ejection and to preserve the printhead in the best condition. Because of the automatic cleaning cycle, you need to perform this manual printhead cleaning operation only if print quality declines. Performing the cleaning more often wastes ink.

1. Turn the printer on and press the Pause button to pause the printer. Make sure that the PAUSE LED is on.
2. Hold down the Alt button and press the Load/Eject button to clean the printhead.

When the printer accepts the panel switch operation, the PAUSE LED flashes during the cleaning cycle. When the cleaning completes, the PAUSE LED stops flashing and returns to PAUSE mode.

### 6.1.2 Waste Ink Drain Tank Replacement

The printer counts the total amount of ink drained to the waste ink tank, and this information is stored in the EEPROM on the main board (Protect counter A) for ink system operation management. If the value of this counter reaches a predetermined value, the printer displays an error ("Waste ink tank overflow," see Chapter 1, Section 1.4.1, Error Conditions, Table 1-14). When this error is displayed, replace the waste ink drain pad and reset the protect counter.

1. Open the upper case and remove the waste ink drain pad from the compartment in the lower case. Insert fresh ink pad and reassemble the printer.
2. Turn the printer while holding down the Alt and Pause buttons.
3. Then holding dawn the Load/Eject for 10-seconds.
4. If printer accepts the reset mode, the Pause and Economy LED starts to brinks. And if printer can not accept, return to step 1.
5. Under this condition, press the Alt button, then initialize operation will be automatically performed. (For detail, refer to Section 4.1.5.)

### 6.1.3 Lubrication and Adhesives

The printer must be lubricated properly when it is disassembled for component replacement, or if mechanical noise exceeds a certain level. EPSON recommends only the lubricants listed in table below for this printer. They have been tested extensively and found to comply with the requirements of this printer mechanism. Figure 6-1 shows the lubrication points.

#### **Warning**

Use only O9 oil when lubricating the carriage guide shaft. If you lubricate with another oil, it could permanently damage the print head unit.

**Table 6-1. Recommended Lubricants**

Type	Name	Quantity	Part No.	Availability
Oil	O-9	TBD	TBD	E
	O-5	40 cc	1010513	E
Grease	G-20	40 gm	B700000001	E
	G-36	40 gm	B703600001	E
Adhesive	NEJI LOCK #2 (G)	1000 g	B730200200	E

**Note:** E = EPSON Exclusive product (not commercially available)

**Table 6-2. Lubrication Points**

Ref. No.	Lubrication Point	Name/Quantity
(1)	Oil pad on the carriage	G-9 (1-3 mg)
(2)	Pick up roller hole on the Pump unit	G-36 (1-3 mg)
(3)	Both sides of the platen unit	G-36 (1-3 mg)
(4)	Pump transmission gear (Black color)	G-36 (1-3 mg)
(5)	Clutch mechanism (Between PF and pump)	G-36 (1-3 mg)
(6)	Left shaft on the paper feed roller unit	G-36 (1-3 mg)
(7)	E-ring on the paper feed roller unit (Right side)	G-36 (1-3 mg)
(8)	Pump transmission gear surface	G-36 (1-3 mg)
(9)	Rail surface on the paper select lever	G-36 (1-3 mg)

**Table 6-2. Adhesive Points**

Ref. No.	Adhesive Point	Name/Quantity
(1)	A part of timing belt securing on the carriage unit	#2 (G) (1-3 mg)

#### **CAUTION**

Do not apply too much lubricant, as it may stain the printer or cause a malfunction of the mechanism.

**Figure 6-1. Lubrication and Adhesive Point**

# Appendix

---

## Table of Contents

<b>A.1 CONNECTOR SUMMARY</b>	<b>A-1</b>
<b>A.1.1 Detail of Connector Summary</b> .....	<b>A-2</b>
<b>A.2 CIRCUIT DIAGRAMS</b>	<b>A-5</b>
<b>A.3 CIRCUIT BOARD COMPONENTS</b>	<b>A-8</b>
<b>A.4 EXPLODED DIAGRAMS</b>	<b>A-12</b>

---

## LIST OF FIGURES

<b>Figure A-1. Interconnection of Major Components</b> .....	<b>A-1</b>
<b>Figure A-2. C160 PSB Board Circuit Diagram</b> .....	<b>A-5</b>
<b>Figure A-3. C160 PSE Board Circuit Diagram</b> .....	<b>A-6</b>
<b>Figure A-4. C160 Main Control Board Circuit Diagram.</b> .....	<b>A-7</b>
<b>Figure A-5. C160 PSB Board Component Layout</b> .....	<b>A-8</b>
<b>Figure A-6. C160 PSE Board Component Layout</b> .....	<b>A-9</b>
<b>Figure A-7. C160 MAIN Control Component Layout.</b> .....	<b>A-10</b>
<b>Figure A-8. C160 I/F Board Component Layout</b> .....	<b>A-11</b>
<b>Figure A-9. Stylus Color IIs(820) Exploded Diagram (1).</b> .....	<b>A-12</b>
<b>Figure A-10. Stylus Color IIs(820) Exploded Diagram (2).</b> .....	<b>A-13</b>
<b>Figure A-11. Stylus Color IIs(820) Exploded Diagram (3).</b> .....	<b>A-14</b>

## LIST OF TABLES

<b>Table A-1. Connector Summary</b> .....	<b>A-2</b>
<b>Table A-2. Connector Pin Assignments – CN1</b> .....	<b>A-2</b>
<b>Table A-3. Connector Pin Assignments – CN2</b> .....	<b>A-3</b>
<b>Table A-4. Connector Pin Assignments – CN3.</b> .....	<b>A-3</b>
<b>Table A-5. Connector Pin Assignments – CN4</b> .....	<b>A-3</b>
<b>Table A-6. Connector Pin Assignments – CN5</b> .....	<b>A-4</b>
<b>Table A-7. Connector Pin Assignments – CN6</b> .....	<b>A-4</b>
<b>Table A-8. Connector Pin Assignments – CN7</b> .....	<b>A-4</b>
<b>Table A-9. Connector Pin Assignments – CN8</b> .....	<b>A-4</b>
<b>Table A-10. Connector Pin Assignments – CN9</b> .....	<b>A-4</b>

## A.1 CONNECTOR SUMMARY

The figure below shows the interconnection between the major components of the Stylus Color IIs / Stylus 820.

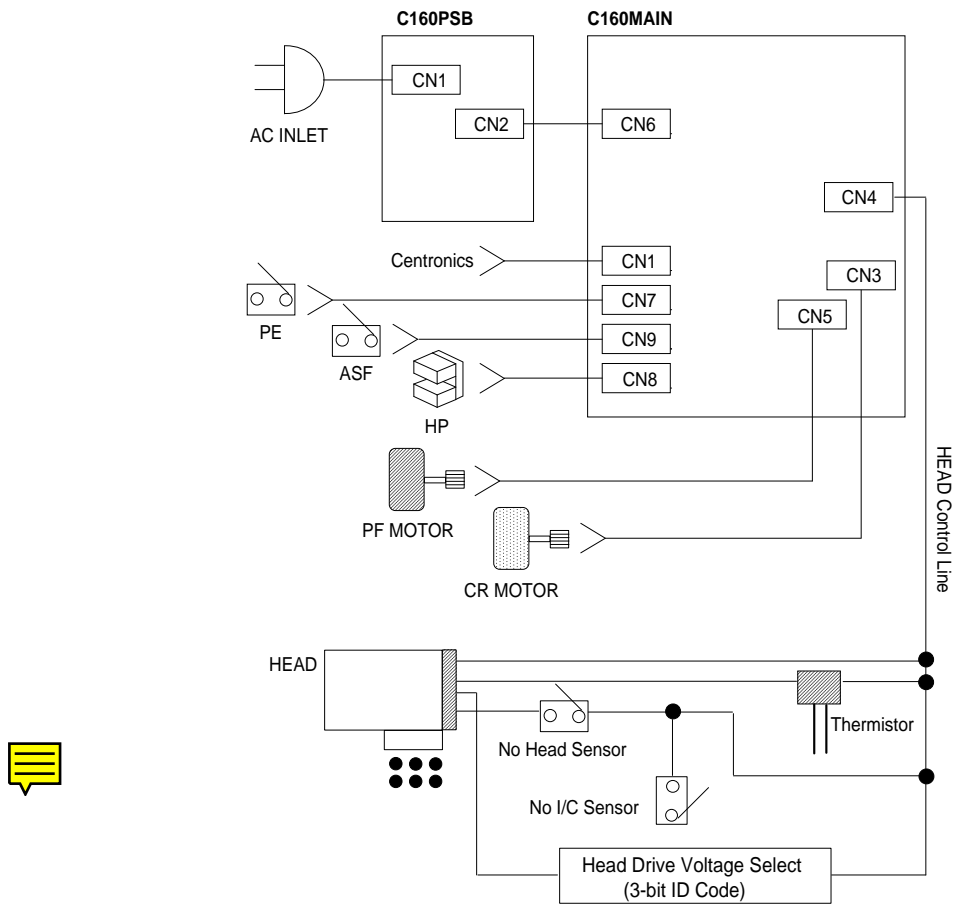


Figure A-1. Interconnection of Major Components

### A.1.1 Connector Summary

This section describes the connector summary. The table A-1 lists the connector summary for every connectors on the C160 main and the C160 power supply board. Also, the table A-2 to table A-10 lists the detail signals for every connectors.

**Table A-1. Connector Summary**

Board	Location	Pin	Description
C160 MAIN	CN1	36	Centronics parallel I/F
	CN2	—	Serial I/Fn (Not Connected)
	CN3	4	Carriage Motor Control
	CN4	19	Head Control
	CN5	4	Paper Feed Motor Control
	CN6	5	Power Supply from C160 PS board
	CN7	2	PE Sensor
	CN8	3	Carriage Home Position Sensor
	CN9	2	Paper Select lever position sensor
C160 PSB/PSE	CN1	2	AC inlet (L/N)
	CN2	8	DC output (+5 V / +35 V)

**Table A-2. Connector Pin Assignments - CN1**

Pin	I/O	Name	Description
1	I	STB	Strobe signal
2-9	I	DATA1-8	Data strobe signal
10	O	ACK	ACK signal
11	O	BUSY	Busy signal
12	O	PE	Paper end signal
13	O	SLCT	Printer select signal
14	I	AFXT	Auto line feed signal
15	—	NC	Not connected
16	—	GND	Ground
17	—	FG	Frame ground
18	—	+5 V	+5 VDC
19-30	—	GND	Ground
31	I	INIT	INIT signal
32	O	ERR	Error signal
33	—	GND	Ground
34	—	NC	Not connected
35	—	+5 V	+5 VDC
36	I	SLIN	Select in signal

**Table A-3. Connector Pin Assignments — CN2**

Pin	I/O	Name	Description
---	---	---	Not connected (Serial I/F)

**Table A-4. Connector Pin Assignments — CN3**

Pin	I/O	Name	Description
1	O	CRA	Bi-poler drive phase A
2	O	CR-A	Bi-poler drive phase -A
3	O	CRB	Bi-poler drive phase B
4	O	CR-B	Bi-poler drive phase -B

**Table A-5. Connector Pin Assignments — CN4**

Pin	I/O	Name	Description
1	—	FG	Frame ground
2	O	VDD	+5VDC
3	I	CO	Cartridge In/Out sensor
4	—	GND	Ground
5	O	HCLK	Clock pulse for transmit the serial 64 bit data
6	—	GND	Ground
7	O	LATCH	Latch signal for once store the serial 64 bit data
8	—	GND	Ground
9	O	SI	Serial 64 bit data output port
10	I	ID4	ID code (Vh level auto-selection)
11	—	GND2	Ground
12	—	GND2	Ground
13	O	COM	Head voltage (+42VDC)
14	O	COM	Head voltage (+42VDC)
15	I	ID1	ID code (Vh level auto-selection)
16	I	ID2	ID code (Vh level auto-selection)
17	I	ID3	ID code (Vh level auto-selection)
18	I	TH	Thermister alalog data
19	I	M/C	Black or Color detection sensor

**Table A-6. Connector Pin Assignments — CN5**

Pin	I/O	Name	Description
1	O	PFA	Bi-poler drive phase A
2	O	PF-A	Bi-poler drive phase -A
3	O	CRB	Bi-poler drive phase B
4	O	CR-B	Bi-poler drive phase -B

**Table A-7. Connector Pin Assignments — CN6**

Pin	I/O	Name	Description
1	I	+42VDC	Power voltage supply from power supply board
2	—	GND	Ground
3	I	+5VDC	Logic voltage supply from power supply board
4	—	GND	Ground
5	I	+42VDC	Power voltage supply from power supply board

**Table A-8. Connector Pin Assignments — CN7**

Pin	I/O	Name	Description
1	I	PE	Paper in/out state detection signal
2	—	GND	Ground

**Table A-9. Connector Pin Assignments — CN8**

Pin	I/O	Name	Description
1	I	HP	Home position detection signal
2	—	GND	Ground
3	O	HPV	Sensor drive power supply

**Table A-10. Connector Pin Assignments — CN9**

Pin	I/O	Name	Description
1	I	ASF	Paper Select lever position sensor
2	—	GND	Ground

## **A.2 CIRCUIT DIAGRAM**

**Figure A-2. C160 PSB Board Circuit Diagram**

**Figure A-3. C160 PSE Board Circuit Diagram**

**Figure A-4. C160 Main Control Board Circuit Diagram**



## **A.3 Circuit Board Component Layout**

**Figure A-5. C160 PSB Board Component Layout**

**Figure A-6. C160 PSE Board Component Layout**

**Figure A-7. C160 Main Control Board Component Layout**

**Figure A-8. C160 I/F Board Component Layout**

## **A.4 Exploded Diagram**

**Figure A-9. Stylus Color IIs(820) Exploded Diagram (1)**

**Figure A-10. Stylus Color IIs(820) Exploded Diagram (2)**

Note: A part of #136 and #134 are only used in Japan.

**Figure A-11. Stylus Color IIs(820) Exploded Diagram (3)**

## REVISION SHEET

Revision	Issue Date	Contents	
Rev.-A	August 25,1995	1st issue	
Rev.-B	October 31,1995	Add the parts list into Appendix	
Rev.-C	November 10, 1995	<b>Page</b>	<b>Detail Position</b>
		1-3	Input buffer: (64 KBto15KB)
		1-12	Table 1-12: Add the EEPROM clear
		2-20	Modify the2nd paragraph& Fig 2-21
		3-13	Modify the caption of Fig 3-18& 3-19
		4-2	Delete the <b>CAUSION</b> message
		4-5	Change the head gap to head angle
		4-8	Step 1: Load/Eject to PAUSE
		5-3	Table5-3: +35V to +42V
6-1	6.1.1, Step 2: Load/eject to Pause		

Character tables: Legal and 14 international sets

**Table 1-2. Character Tables**

Character Tables		Bitmap Fonts	Scalable Fonts	
		EPSON Roman EPSON Saris Serif EPSON Courier	EPSON Roman EPSON Saris Serif	EPSON Roman T EPSON Saris Serif H
Standard	Italic	Supported	Supported	Supported
	PC437 (U.S./Standard Europe)			
	PC850 (Multilingual)			
	PC860 (Portuguese)			
	PC861 (Icelandic)			
	PC863 (Canadian-French)			
	PC865 (Nordic)			
	Abicomp BRASCII			
NLSP	Italic	Supported	Supported	Supported
	PC437 (U.S./Standard Europe)			
	PC850 (Multilingual)			
	PC437 (Greek)	Supported	Supported	Not supported
	PC852 (East Europe)			
	PC853 (Turkish)			
	PC855 (Cyrillic)			
	PC857 (Turkish)			
	PC866 (Russian)			
	PC869 (Greek)			
	MAZOWIA (Poland)			
	Code MJK (Czechoslovakia)			
	ISO 8859-7 (Latin/Greek)			
	ISO Latin IT (Turkish)			
Bulgaria (Bulgaria)				

Fonts: *Bitmap LQ fonts*  
 - EPSON Roman (10 cpi/12 cpi/15 cpi/Proportional)  
 - EPSON **Sans Serif** (10/12/15/Proportional)  
 - EPSON Courier (10/12/15)

*Scalable fonts*  
 - EPSON Roman 10.5 points, 8-32 points (in units of 2 points)  
 - EPSON Saris Serif 10.5 points, 8-32 points (in units of 2 points)  
 - EPSON Roman T 10.5 points, 8-32 points (in units of 2 points)  
 - EPSON Saris Serif H 10.5 points, 8-32 points (in units of 2 points)

Control codes: ESC/P 2 and expanded raster graphics codes

Input data buffer: 0.5KB or 15KB(Depending on the installed printhead unit)

Table 1-12. Built-in Functions on the Panel

Button	Function
Alt	Demonstration printing
Load/Eject	Self-test
Pause	Default setting mode (with printing)
Alt + Load/Eject	Non-smear printing
Load/Eject + Pause	Data dump mode (Hex mode)
Pause + Alt	1) Default setting mode (without printing) 2) EEPROM reset mode (Refer to 4.1.5 in detail)
Pause + Load/Eject + Alt	<b>Reset</b> to the default settings
Other combinations	Not available

Table 1-13. Button Operations in Default Setting Mode

Button	Function
Alt	Move to the next item or menu
Pause	Set item

### 2.3.2 Operating Principles of the Main Control Circuit

The main control circuit for this printer is the C160 MAIN Board, which is controlled by the 16-bit CPU M3772 (IC2), running at 16 MHz. This CPU has a unique architecture capable of handling data on the data bus at either an 8-bit or 16-bit bus width. Because of this, a 16-bit or 8-bit data bus width-type ROM is used on this board, increasing the internal processing speed. Additionally, auto refresh for the IM PS-RAM is controlled by custom gate array E05B08 (IC1). Also this CPU manages the controls that create the 2-bit signal for the carriage or the paper feed motor. (The carriage and paper feed motors are controlled by current duty data with micro step control.)

Gate array E05B08 (IC1) manages printhead drive control, the parallel I/F, extension CG board, and the control panel. This board also is equipped with EEPROM 93C46 (IC10) to store certain parameters, such as the printer mechanism control parameters, default setting parameters, as well as the value in the special counter used for printhead (ink management) protection.

Because this control board has no lithium battery that allows the printer to keep track of the amount of time that has elapsed since it was last used, there is no power on cleaning operation for this printer.

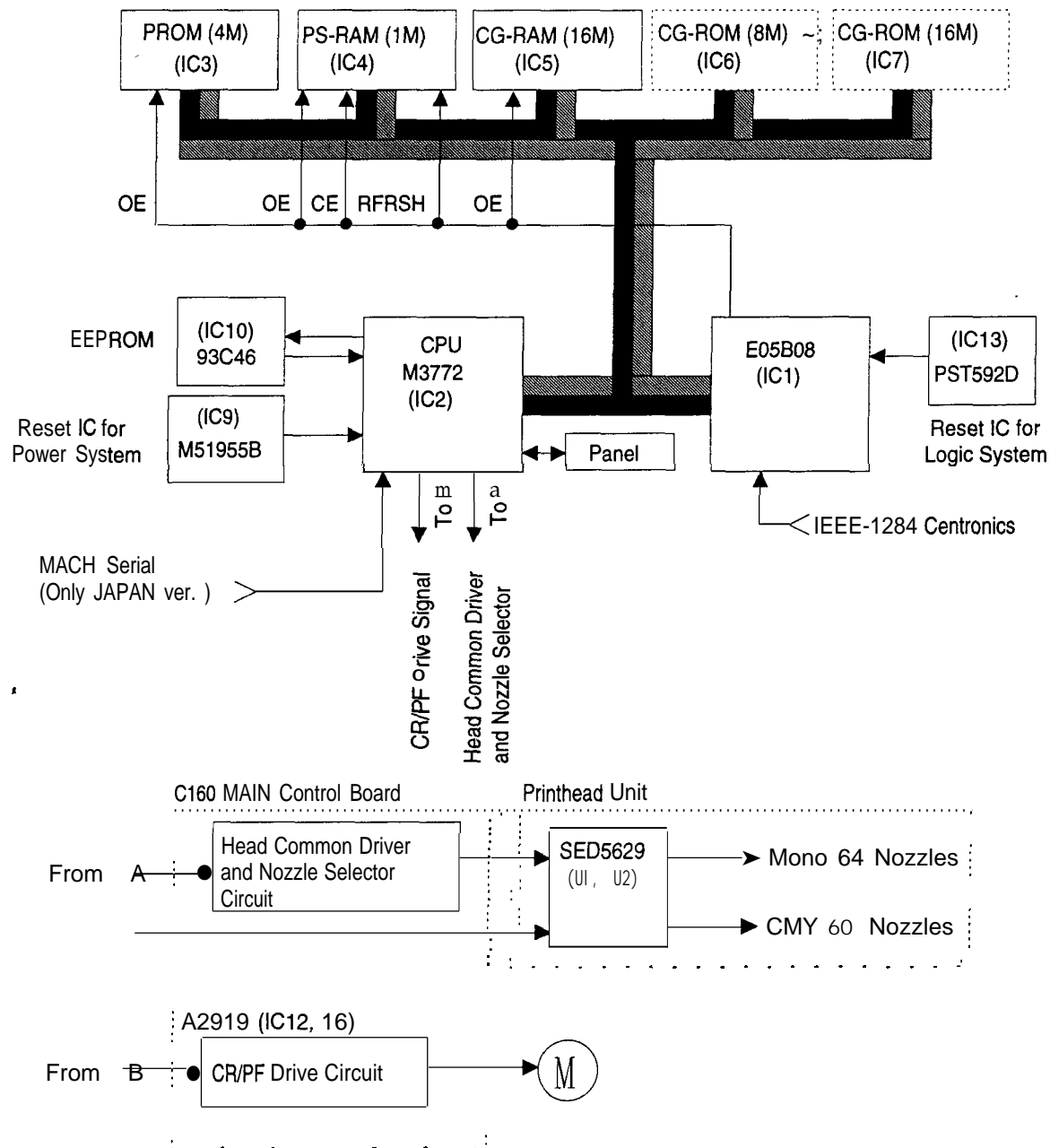
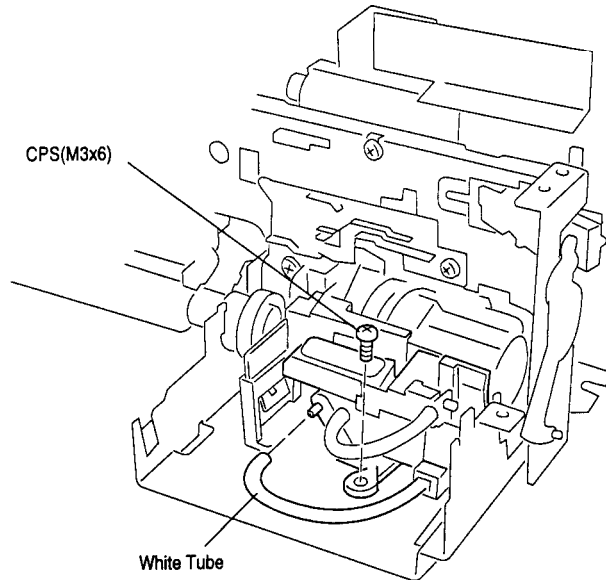


Figure 2-21. Main Control Circuit Block Diagram

### 3.2.6.9 Pump Unit Removal

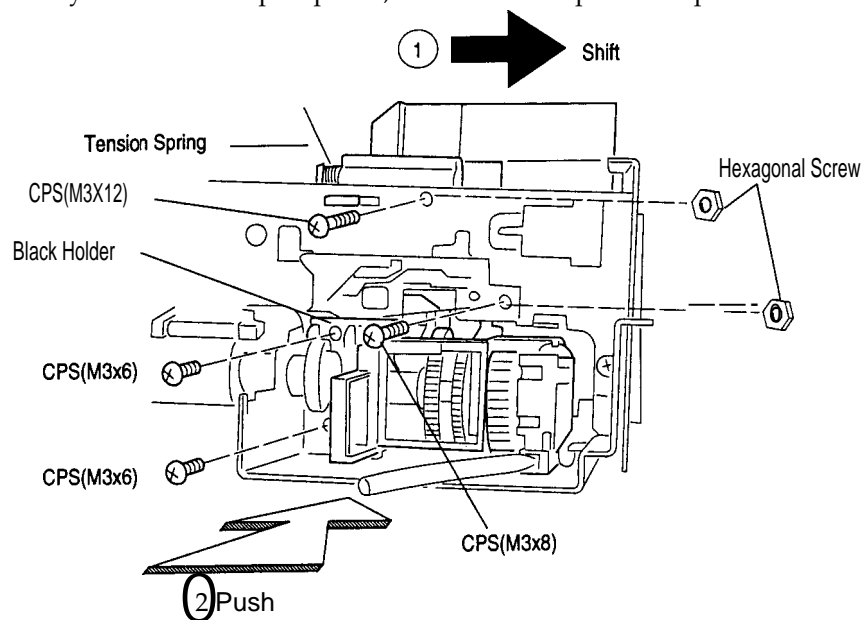
1. Remove the printer mechanism (see Section 3.2.5).
2. Remove the front frame (see Section 3.2.6.6).
3. Remove 1 CPS(M3x6) screw securing the cap unit to the lower frame.



**Figure 3-18. Pump Unit Removal (1)**

4. Remove 1 CPS(M3x6) screw securing the black holder to the frame
5. Remove the white tube **connecting** the cap unit to the pump unit. (Be careful an ink leak when you remove this ink tube.)
6. Remove 3 screws — 1 CPS (M3x6), 1 CPS (M3x12), and 1 CPS (M3x8) — securing the pump unit to the main frame.
7. Release a tension spring securing the paper pickup trigger holder to the pump mechanism.

Notes: 1. When you remove the pump unit, be sure to keep the washer, located behind the pump.  
2. When you remove the pump unit, do not lose the pin in the pin holder.



**Figure 3-19. Pump Unit Releasing (2)**

### 4.1.1 Destination Data Writing Operation

The setup value that specifies the printer destination (for character generation and panel default settings) is stored in the EEPROM on the C160 MAIN Board. Therefore, this setup value must be written into the EEPROM when the main board or EEPROM chip is replaced.

1. Connect the PC to the target printer using a parallel interface cable and turn the printer on.
2. Execute BASIC on the PC, and run the program HUDSON.BAS. You see the following menu:

```
Stylus / MJ Program H90E00E
**** Model ****
1. Stylus Color IIs
2. Stylus 820
3. MJ-500C
7. END
```

3. When the main menu appears, choose the product name by typing 1 or 2 and Enter.
4. You see the following menu.

```
Stylus / MJ Program H90E00E
**** Customer ****
1. EAI,EAI (Latin America), EAL, ESP, ETT
2. EUL, EDG, EFS, EIS, EIB, EUL (North Europe), EUL (Middle East), EHK
3. [EDG (NLSP)]
4. Russia

Sleet Menu ?
```

5. Select your country.
6. If you have completed all your selections, turn off the printer.

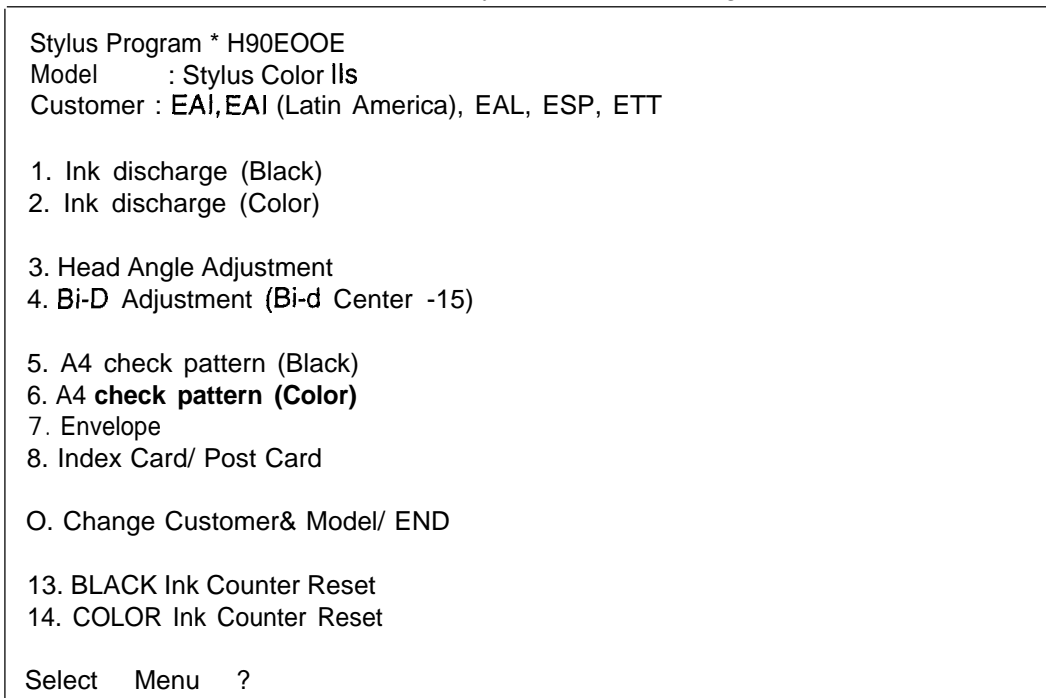
**Note:** It is not necessary to turn off the printer if you want to perform the other adjustments.

### 4.1.3 Head Angle Adjustment (Black and Color Head)

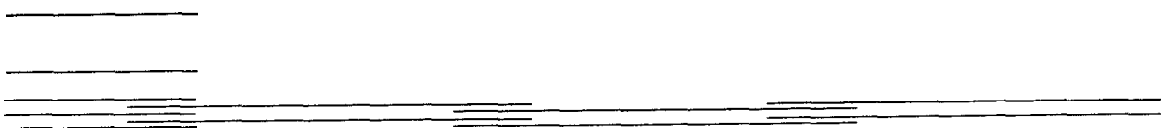
The head angle adjustment is required when the printer mechanism, main board, or printhead (board) is replaced or disassembled. This adjustment calibrates the head drive timing between the black and color head. If this adjustment is not made, the vertical alignment will not be completed.

**Note:** Use only a black head unit when you perform the head angle adjustment. Also, use only a normal plain paper, because the type of black ink is using the slow penetration type.

1. Perform steps 1 to 5 in Section 4.1.1. Then you see the following menu:

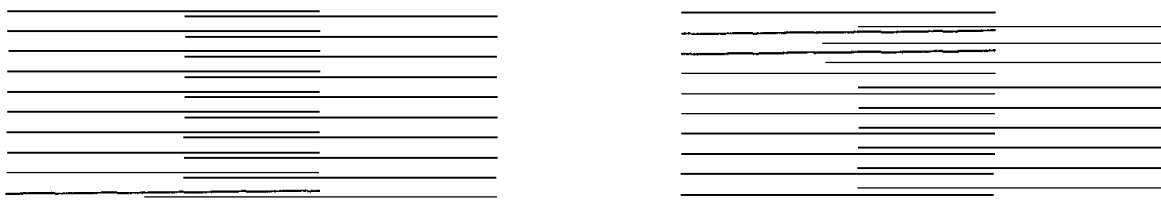


2. Choose "Head Angle Adjustment" by typing **3** and **ENTER**. Then the printer prints an angle adjustment check pattern. If the head angle is correct you see the following angle adjustment pattern.



**Figure 4-2. Head Angle Pattern (Angle Correct)**

3. If the angle adjustment is incorrect, you see a pattern similar to the one below. If this is the case, go to step 4.



**Figure 4-3. Head Angle Pattern (Angle Incorrect)**

### 4.1.5 EEPROM Reset Procedure

This operation is required when the C160 MAIN Board is replaced, when the waste ink drain pad is replaced, or to recover from printer malfunction. There are two reset methods for this printer. (Reset All and Reset Maintenance Error Only)

#### Reset All

1. Turn printer power on while pressing the ALT and Pause buttons.
2. Hold down the Load / Eject button for 10 seconds.

*Note:* The Pause and Economy LEDs start to blink when printer accepts the reset mode. If the Pause and Economy LEDs do not start to blink, return to step 1.

3. Press the Pause button. Then printer starts initialization automatically.

#### Reset Maintenance Error Only

1. Turn printer power on while pressing the ALT and Pause buttons.
2. Hold down the Load / Eject button for 10 seconds.

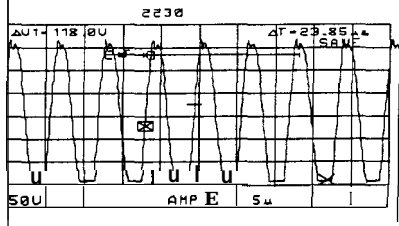
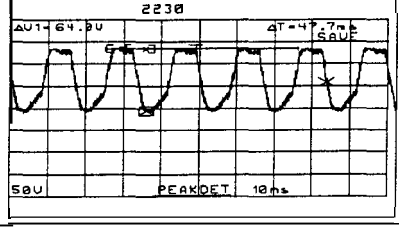
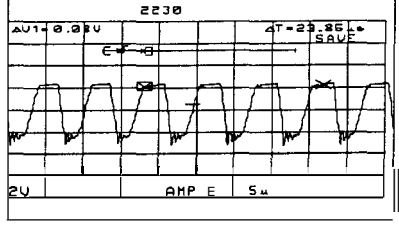
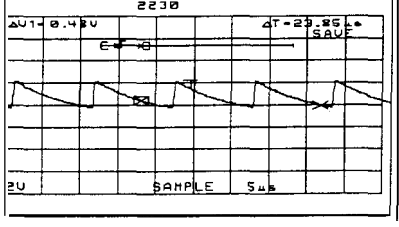
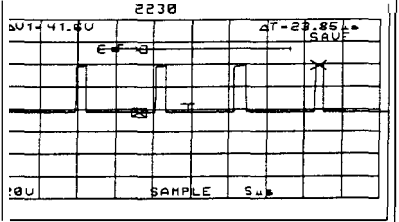
*Note:* The Pause and Economy LEDs start to blink when printer accepts the reset mode. If the Pause and Economy LEDs do not start to blink, return to step 1.

3. Press the Alt button. Then printer starts initialization automatically.

## 5.2 Unit-Repair - C160 Power Supply Board

This section describes how to repair the C160 power supply board and main board. The table below provides various symptoms, likely causes, and check points. The checkpoints refer to waveforms, resistances, and other values to check to evaluate the operation of each component.

**Table 5-3. Repair of the C160 PSB / PSE**

Symptom	Condition	Cause	Checkpoints	Solution
Printer does not operate at all.	+42V line is dead.	F1 is open.	Check the F1.	Replace F1.
		T1 is open.	Check T1 coils using the tester.	Replace T1.
		Q1 is broken	Check the wave-form at the drain of Q1. 	Replace Q1.
		Q2 or Q3 is broken.	Check the wave-form at the drain of Q2 and Q3. 	Replace Q2 or Q3.
		PC1 is broken.	Check the wave-form at 3-pin of PC1. 	Replace PC1.
		+5V is dead.	.4962 is broken.	Check the oscillation at 5-pin of IC51. 
Check the output wave-form at 7-pin of IC51. 	Replace IC51.			

## 6.1 PREVENTIVE MAINTENANCE

This printer must be lubricated only 09 when you need a lubrication for carriage guide shaft. If you lubricate with another oil, it could permanently damage the print head unit..

Although this printer requires no specific maintenance on a regular basis, recommends that you clean the following thoroughly whenever you get a chance.:

Outer case

Use a soft, clean cloth, dampened with mild detergent, if necessary.

Auto sheet feeder

If the inside of the auto sheet feeder is dirty (dusty), carefully brush away all dust and dirt using a soft brush. If the pickup roller of the sheet feeder is dirty, clean its surface with a soft, clean cloth.

Inside the printer

If you notice any dust or dirt that has accumulated inside the printer when you open the outer case for repair, remove all dust and dirt using a small vacuum cleaner designed for such purposes.

### Warning

- Use only 09 oil when **lubricating the carriage guide shaft**. If you lubricate with another oil, it could permanently damage the **print head unit**.
- Never use **paint thinner, trichloroethylene, or ketone-based solvents for cleaning**. These chemicals can damage the components the **printer**.
- Do not use a **hard or abrasive brush for cleaning**.
- Be careful not to damage the components of the printer when using a vacuum clean&.**

### 6.1.1 Printhead Cleaning

If print quality deteriorates, clean the **printhead** using the built-in **printhead** cleaning function. The printer also has an automatic **printhead** cleaning cycle to ensure proper nozzle operation for ink ejection and to **preserve the printhead** in the best condition. Because of the automatic cleaning cycle, you need to perform this manual **printhead** cleaning operation only if print quality declines. Performing the cleaning more often wastes ink.

1. **Turn the printer on and press the Pause button** to pause the printer. Make sure that the **PAUSE LED** is on.
2. Hold down **the Alt button** and press the **Pause button** to clean the **printhead**.

When the printer accepts the panel switch operation, the **PAUSE LED** flashes during the cleaning cycle. When the cleaning completes, the **PAUSE LED** stops flashing and returns to **PAUSE** mode.

### 6.1.2 Waste Ink Drain Tank Replacement

The printer counts the total amount of ink drained to the waste ink tank, and this information is stored in the EEPROM on the main board (Protect counter A) for ink system operation management. If the value of this counter reaches a predetermined value, the printer displays an error (Refer to table 1-14 in Section 1.4.2). When this error is displayed, replace the waste ink drain pad and reset the protect counter.

1. **Open the upper case and remove the waste ink drain pad** from the compartment **in the lower case**. Insert fresh ink pad and reassemble the printer.
2. **Turn the printer while holding down the Alt and Pause buttons**.
3. Then holding dawn the **Load/Eject** for 10-seconds.
4. **If printer accepts the reset mode, the Pause and Economy LED starts to brinks. And if printer can not accept, return to step 1.**
5. Under **this condition, press the Alt button, then initialize operation will be automatically performed.** (For detail, refer to Section 4.1.5.)

### 6.1.3 Lubrication and Adhesives

The printer must be lubricated properly when it is disassembled for component replacement, or if mechanical noise exceeds a certain level. EPSON recommends only the lubricants listed in table below for this printer. They have been tested extensively and found to comply with the requirements of this printer mechanism. Figure 6-1 shows the lubrication points.

#### **Warning**

**Use only O9 oil when lubricating the carriage guide shaft. If you lubricate with another oil, it could permanently damage the print head unit.**

**Table 6-1. Recommended Lubricants**

Type	Name	Quantity	Part No.	Availability
Oil	O-9	40 gm	B102588000	E
	G-36	40 gm	B703600001	E
Adhesive	NEJI LOCK #2 (G)	1000 g	B730200200	E

**Note:** E= EPSON Exclusive product (not commercially available)

**Table 6-2. Lubrication Points**

Ref. No.	Lubrication Point	Name/Quantity
(1)	Oil pad on the carriage	O-9 (1-3 mg)
(2)	Pick up roller hole on the Pump unit	G-36 (1-3 mg)
(3)	Both sides of the platen unit	G-36 (1-3 mg)
(4)	Pump transmission gear (Black color)	G-36 (1-3 mg)
(5)	Clutch mechanism (Between PF and pump)	G-36 (1-3 mg)
(6)	Left shaft on the paper feed roller unit	G-36 (1-3 mg)
(7)	E-ring on the paper feed roller unit (Right side)	G-36 (1-3 mg)
(8)	Pump transmission gear surface	G-36 (1-3 mg)
(9)	Rail surface on the paper select lever	G-36 (1-3 mg)

**Table 6-3. Adhesive Points**

Ref. No.	Adhesive Point	Name/Quantity
(1)	A part of timing belt securing on the carriage unit	#2 (G) (1-3 mg)

#### **CAUTION**

**Do not apply too much lubricant, as it may stain the printer or cause a malfunction of the mechanism.**

## **EPSON OVERSEAS MARKETING LOCATIONS**

---

### **EPSON AMERICA INC.**

20770 Madrona Avenue,  
P.O. Box 2842  
Torrance, CA 90509-2842  
Phone: (800) 922-8911  
Fax: (310) 782-5220

### **EPSON DEUTSCHLAND GmbH**

Zülpicher Straße 6, 40549 Düsseldorf  
F.R. Germany  
Phone: 0211-56030  
Fax : 0211-504-7787

---

### **EPSON UK LTD.**

Campus 100, Maylands Avenue,  
Hemel Hempstead, Herts.  
HP2 7TJ, U.K.  
Phone: 1442-61144  
Fax: 1442-227227

### **EPSON FRANCE S.A.**

68 bis, rue Marjolin 92300,  
Levallois-Perret, France  
Phone: 1-4087-3737  
Fax : 1-47-371510

---

### **EPSON IBERICA, S.A.**

Avda. de Roma, 18-26  
08290 Cerdanyola del Valles  
Barcelona, Spain  
Phone: 582.15.00  
Fax : 582.15.55

### **EPSON ITALIA S.p.A.**

V. le F. Ili Casiraghi, 427  
20099 Sesto S. Giovanni MI, Italy  
Phone: 02-262331  
Fax : 02-2440750

---

### **EPSON AUSTRALIA PTY. LTD.**

1/70 Gibbes Street,  
Chatswood 2067 NSW, Australia  
Phone: 02-415-9000  
Fax : 02-417-0077

### **EPSON (SINGAPORE) PTE, LTD.**

No. 1 Raffles Place #26-00  
OUB Centre, Singapore 0104  
Phone: 5330477  
Fax: 5338119

---

### **EPSON HONG KONG LTD.**

20/F, Harbour Centre,  
25 Harbour Road, Wanchai,  
Hong Kong  
Phone: 585-4600  
Fax: 827-4346

### **EPSON ELECTRONICS TRADING LTD.**

(TAIWAN BRANCH)  
10F, No.287 Nanking E. Road, Sec. 3,  
Taipei, Taiwan, R.O.C.  
Phone: 2-717-7360  
Fax: 2-712-9164

---

### **SEIKO EPSON CORPORATION**

PRINTER DIVISION  
80 Harashinden, Hirooka Shiojiri-shi,  
Nagano-ken, 399-07, JAPAN  
Phone: 0263-52-2552  
Fax: 0263-54-4007  
Telex: 3342-214 (SEPSON J)