

# SERVICE MANUAL

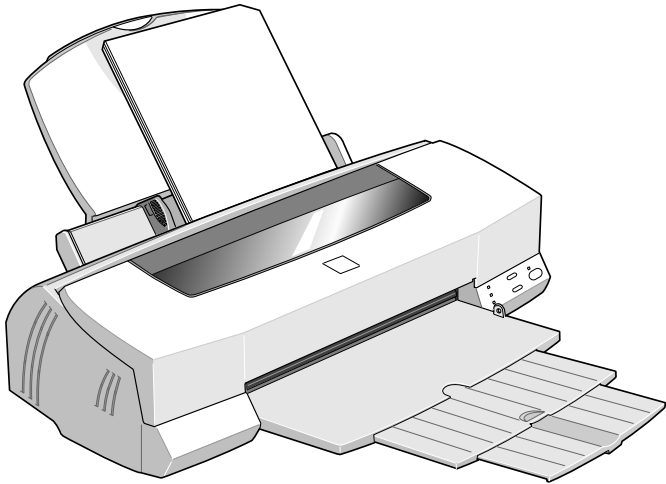

sp01

Color Inkjet Printer

**EPSON Stylus Photo 1200**



**EPSON®**

SEIJ98007

## Notice

- All rights reserved. No part of this manual may be reproduced, stored in a retrieval system, or transmitted in any form or by any means electronic, mechanical, photocopying, or otherwise, without the prior written permission of SEIKO EPSON CORPORATION.
- All effort have been made to ensure the accuracy of the contents of this manual. However, should any errors be detected, SEIKO EPSON would greatly appreciate being informed of them.
- The contents of this manual are subject to change without notice.
- All effort have been made to ensure the accuracy of the contents of this manual. However, should any errors be detected, SEIKO EPSON would greatly appreciate being informed of them.
- The above notwithstanding SEIKO EPSON CORPORATION can assume no responsibility for any errors in this manual or the consequences thereof.

EPSON is a registered trademark of SEIKO EPSON CORPORATION.

*General Notice: Other product names used herein are for identification purpose only and may be trademarks or registered trademarks of their respective owners. EPSON disclaims any and all rights in those marks.*

# PRECAUTIONS

Precautionary notations throughout the text are categorized relative to 1) Personal injury and 2) damage to equipment.

**DANGER** Signals a precaution which, if ignored, could result in serious or fatal personal injury. Great caution should be exercised in performing procedures preceded by DANGER Headings.

**WARNING** Signals a precaution which, if ignored, could result in damage to equipment.

The precautionary measures itemized below should always be observed when performing repair/maintenance procedures.

## **DANGER**

1. ALWAYS DISCONNECT THE PRODUCT FROM THE POWER SOURCE AND PERIPHERAL DEVICES PERFORMING ANY MAINTENANCE OR REPAIR PROCEDURES.
2. NO WORK SHOULD BE PERFORMED ON THE UNIT BY PERSONS UNFAMILIAR WITH BASIC SAFETY MEASURES AS DICTATED FOR ALL ELECTRONICS TECHNICIANS IN THEIR LINE OF WORK.
3. WHEN PERFORMING TESTING AS DICTATED WITHIN THIS MANUAL, DO NOT CONNECT THE UNIT TO A POWER SOURCE UNTIL INSTRUCTED TO DO SO. WHEN THE POWER SUPPLY CABLE MUST BE CONNECTED, USE EXTREME CAUTION IN WORKING ON POWER SUPPLY AND OTHER ELECTRONIC COMPONENTS.

## **WARNING**

1. REPAIRS ON EPSON PRODUCT SHOULD BE PERFORMED ONLY BY AN EPSON CERTIFIED REPAIR TECHNICIAN.
2. MAKE CERTAIN THAT THE SOURCE VOLTAGES IS THE SAME AS THE RATED VOLTAGE, LISTED ON THE SERIAL NUMBER/ RATING PLATE. IF THE EPSON PRODUCT HAS A PRIMARY AC RATING DIFFERENT FROM AVAILABLE POWER SOURCE, DO NOT CONNECT IT TO THE POWER SOURCE.
3. ALWAYS VERIFY THAT THE EPSON PRODUCT HAS BEEN DISCONNECTED FROM THE POWER SOURCE BEFORE REMOVING OR REPLACING PRINTED CIRCUIT BOARDS AND/OR INDIVIDUAL CHIPS.
4. IN ORDER TO PROTECT SENSITIVE MICROPROCESSORS AND CIRCUITRY, USE STATIC DISCHARGE EQUIPMENT, SUCH AS ANTI-STATIC WRIST STRAPS, WHEN ACCESSING INTERNAL COMPONENTS.
5. REPLACE MALFUNCTIONING COMPONENTS ONLY WITH THOSE COMPONENTS BY THE MANUFACTURE; INTRODUCTION OF SECOND-SOURCE ICs OR OTHER NONAPPROVED COMPONENTS MAY DAMAGE THE PRODUCT AND VOID ANY APPLICABLE EPSON WARRANTY.

# About This Manual

This manual describes basic functions, theory of electrical and mechanical operations, maintenance and repair procedures of EPSON Stylus Photo 1200. The instructions and procedures included herein are intended for the experienced repair technicians, and attention should be given to the precautions on the preceding page.

## Contents

This manual consists of six chapters and Appendix.

### **CHAPTER 1. PRODUCT DESCRIPTIONS**

Provides a general overview and specifications of the product.

### **CHAPTER 2. OPERATING PRINCIPLES**

Describes the theory of electrical and mechanical operations of the product.

### **CHAPTER 3. TROUBLESHOOTING**

Provides the step-by-step procedures for the troubleshooting.

### **CHAPTER 4. DISASSEMBLY AND ASSEMBLY**

Describes the step-by-step procedures for disassembling and assembling the product.

### **CHAPTER 5. ADJUSTMENTS**

Provides Epson-approved methods for adjustment.

### **CHAPTER 6. MAINTENANCE**

Provides preventive maintenance procedures and the lists of Epson-approved lubricants and adhesives required for servicing the product.

**APPENDIX** Provides the following additional information for reference:

- Connector pin assignments
- Electric circuit boards components layout
- Exploded diagram
- Electrical circuit boards schematics

## Symbols Used in This Manual

Various symbols are used throughout this manual either to provide additional information on a specific topic or to warn of possible danger present during a procedure or an action. Be aware of all symbols when they are used, and always read WARNING, CAUTION or NOTE messages.



Indicates an operating or maintenance procedure, practice or condition that, if not strictly observed, could result in injury or loss of life.



Indicates an operating or maintenance procedure, practice, or condition that, if not strictly observed, could result in damage to, or destruction of, equipment.



May indicate an operating or maintenance procedure, practice or condition that is necessary to accomplish a task efficiently. It may also provide additional information that is related to a specific subject, or comment on the results achieved through a previous action.



# Table of Contents

## *Product Description*

---

Overview.....	8
General Characteristics.....	8
Basic Specification .....	8
Interface.....	11
Operation Specification .....	11
Major Components .....	12
Consumables.....	12

## *Operating Principles*

---

Overview.....	14
---------------	----

## *Troubleshooting*

---

## *Disassembly and Assembly*

---

## *Adjustment*

---

Overview.....	20
Adjustments.....	20
Adjustment Program.....	21
Activatioin of Program .....	21

## *Maintenance*

---

## *Appendix*

---

Exploded Diagram .....	26
Circuit Boards .....	32

**CHAPTER**

**1**

**PRODUCT DESCRIPTION**

## 1.1 Overview

---

Stylus Photo 1200 is 127 digits color ink jet printer whose function and characteristics are based on Stylus Photo 750. Therefore, since only revised points for Stylus Photo 1200 are explained in this manual, refer to the Service Manual of Stylus Photo 750 for the rest of information.

### 1.1.1 General Characteristics

- High Color Print Quality
  - 1440(H) x 720(V) dpi printing
  - 6-Color printing(YMCKcm)
  - Traditional and New Microweave
- Built-in auto sheet feeder
  - Holds 100 cut-sheets (64 g/m<sup>2</sup>)
  - Holds 10 envelopes
  - Holds 30 transparency films
- Built-in 3 I/F
  - Mac. serial I/F (up to approx. 1800kbps)
  - Bi-directional parallel I/F(IEEE-1284 level 1 device)
  - USB
- Windows/Macintosh exclusive

## 1.2 Basic Specification

---

### PAPER SPECIFICATION

---

- Paper Size
  - Cut Sheet
    - A3 (297mm x 420mm)
    - B (279mm x 432mm)
    - B4 (257mm x 364mm)
  - Envelope
    - 220 x 132 (220mm x 132mm)
  - EPSON Special Media (Photo Quality Ink Jet Paper, 360 dpi Ink Jet Paper, Photo Quality Glossy Film, Photo Paper)
    - A3+ (329mm x 483mm)
    - B (279mm x 432mm)
    - B4 (257mm x 364mm)

**NOTE:** Other paper specification is same as EPSON Stylus Photo 750.

### CHARACTER TABLES

---

- 2 international character sets
  - PC 437 (US, Standard Europe)
  - PC 850 (Multilingual)

### TYPE FACE

---

- Bit map LQ font: EPSON Courier 10 CPI

**PRINTABLE AREA**

Printable area is as follows.

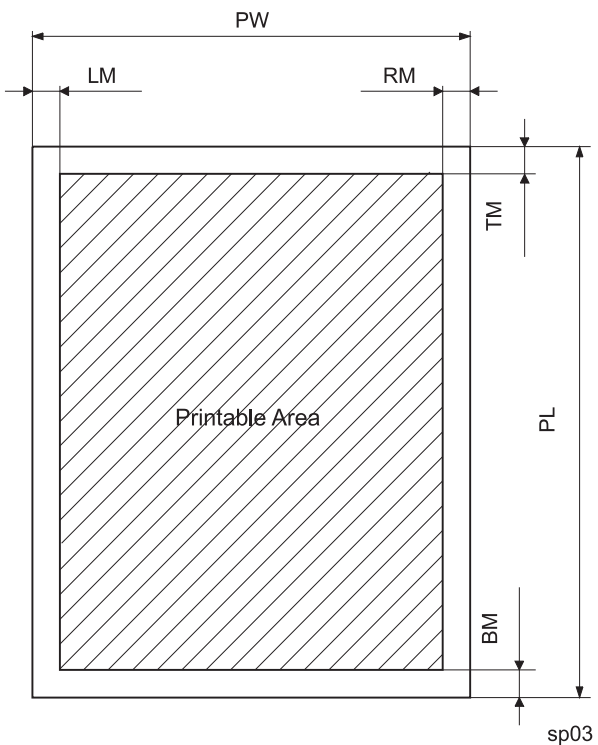

**Figure 1-1. Printable Area**

**Table 1-1. Printable Area(mm)**

Paper Size	Paper Width (PW)	Paper Length (PL)	Left Margin (LM)	Right Margin (RM)	Top Margin (TM)	Bottom Margin (BM)
A3+	329	483	More than 3	More than 3	More than 3	14 or more than 3
A3	297	420				3

---

**INK**

---

- Color Ink Cartridge
  - Type: Exclusive cartridge
  - Color: Magenta, Cyan, Yellow, Light Ma, Light Cyan
  - Print Capacity: 330 pages/A4 (360 dpi, 5% duty each color)
  - Ink life: 2 years from production date
  - Storage Temperature
    - 20 °C ~ 40 °C (Storage, within a month at 40 °C)
    - 30 °C ~ 40 °C (Packing storage, within a month at 40 °C)
    - 30 °C ~ 60 °C (Transit, within 120 hours at 60 °C and within a month at 40 °C)
  - Dimension: 42.9mm (W) x 52.7mm (D) x 38.5mm (H)

**NOTE:** Ink cartridge can not re-fill, only ink cartridge is prepared for article of consumption.

*Do not use the ink cartridge which was passed away the ink life.*

*Ink will be frozen under - 4 °C environment, however it will be usable after placing it more than 3 hours at room temperature.*

**NOTE:** Specification of black ink cartridge is same as Stylus Photo 750.

---

**PHYSICAL SPECIFICATION**

---

- Dimension: 578mm(W) x 286mm(D) x 175mm(H)
- Weight: 7 Kg

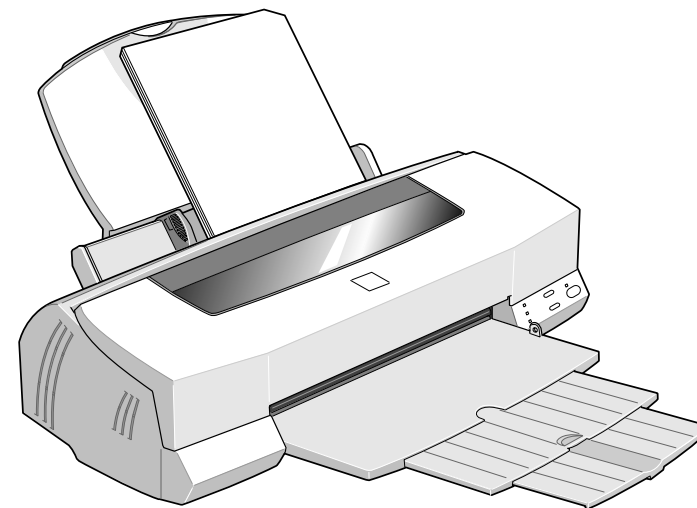

sp01

**Figure 1-2. Exterior View of Stylus Photo 1200**

## 1.3 Interface

Stylus Photo 1200 is equipped with the same interfaces as Stylus Photo 750. Therefore, refer to the Service Manual of Stylus Photo 750 for interface specification.

- IEEE-1284 Nibble Mode Parallel I/F
- Serial I/F(RS-423)
- Universal Serial Bus Specification Revision 1.0

## 1.4 Operation Specification

Although the specification and function of buttons and LED lights are the same as those of Stylus Photo 750, the panel layout is different. See the figure below.

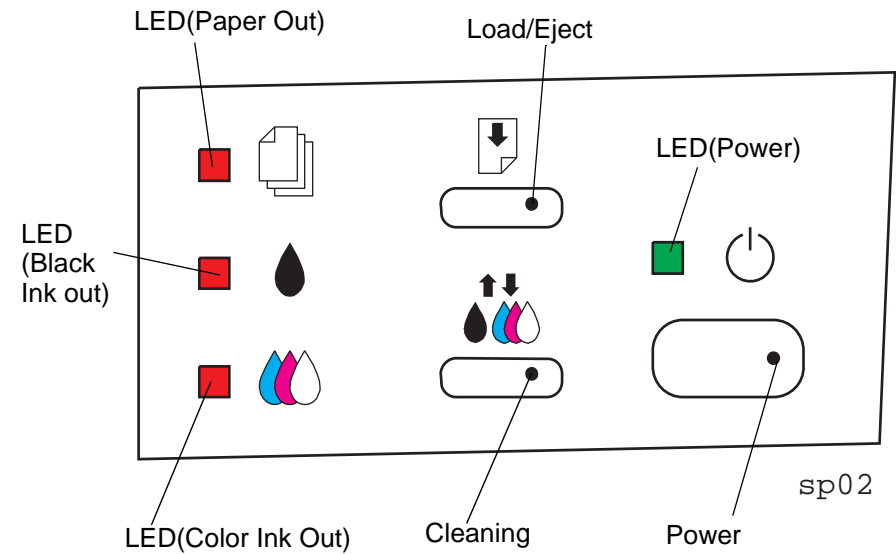

Figure 1-3. Control Panel

## 1.5 Major Components

Major components which consist Stylus Photo 1200 are as follow.

- Control Board: C264 Main or C259 Main Board  
(Circuit and pattern are same in the both boards, but connector shapes are different)
- Power Supply Board: C257 PSB Board (same board used in Stylus Photo 750)
- Control Panel: C206 PNL Board (same PNL board used in Stylus Photo EX)
- Printer Mechanism: M-4N60

## 1.6 Consumables

Consumable of this printer are as follow.

**Table 1-2. Consumables**

Code No.	Name
S020187	Black ink cartridge
T001011, T001051, T001091, T001311	Color ink cartridge

**NOTE:** Color ink cartridge for Stylus Photo 750 can not be used for Stylus Photo 1200.

**CHAPTER**

**2**

**OPERATING PRINCIPLES**

## 2.1 Overview

---

Comparing with Stylus Photo750, following points in Stylus Photo1200 are different from Stylus Photo 750.

- Printer Mechanism
  - Since Stylus Photo1200 can deal with A3+ size, mechanism is extended from 80 digits to 127 digits.
  - Size of color ink cartridge is changed, since the color ink life is improved.
- Electric Circuit
  - Circuit component of Stylus Photo1200 is same as that of Stylus Photo 750.
  - Control panel board(C206 PNL Board) is also used for Stylus Photo EX and Stylus Color 400.

Therefore, since the printer mechanism and electric circuit of Stylus Photo 1200 are basically same as those of Stylus Photo 750, refer to the Service Manual of Stylus Photo 750 for more details.

**CHAPTER**

**3**

**TROUBLESHOOTING**

Since EPSON Stylus Photo 1200 is a ink jet printer based on the function and characteristics of ESPON Stylus Photo 750, refer to the Service Manual of EPSON Stylus Photo 750 for troubleshooting.

**CHAPTER**

**4**

**DISASSEMBLY AND ASSEMBLY**

Since the basic component of EPSON Stylus Photo 1200 is same as that of EPSON Stylus Photo750, refer to the Service Manual of EPSON Stylus Photo 750 for disassembly and assembly procedures.

**CHAPTER**

**5**

**ADJUSTMENT**

## 5.1 Overview

This section will explain required adjustment procedures for this printer after disassembling or replacing parts.

### 5.1.1 Adjustments

Since the basic components and function of this printer is same as those of Stylus Photo 750, both printers share the same adjustment items. Therefore, adjustment items only for Stylus Photo 1200 are explained here.

**Table 5-1. Required Adjustments**

Priority order	1	2	3	4	5
Procedure/ Replacing parts	Paper Gap Adjustment	Ink initial charge	Head ID Writing	Head Angular Adjustment	Bi-D Adjustment
Printer Mechanism Exchange	--	O	O	---	O
Control Board Exchange	--	O	O	O	O
Print Head Exchange	--	O	O	O	---
CR Motor Exchange	---	---	---	---	O
Carriage Assembly Removal/ Exchange	O	---	---	O	O
Roller Assembly/ Removal/Exchange	O	---	---	---	---

**NOTE:** 1. "O" means adjustment is required. "---" means adjustment is not required.

**NOTE:** 2. Initial ink charge should be done after installing the new ink cartridge.

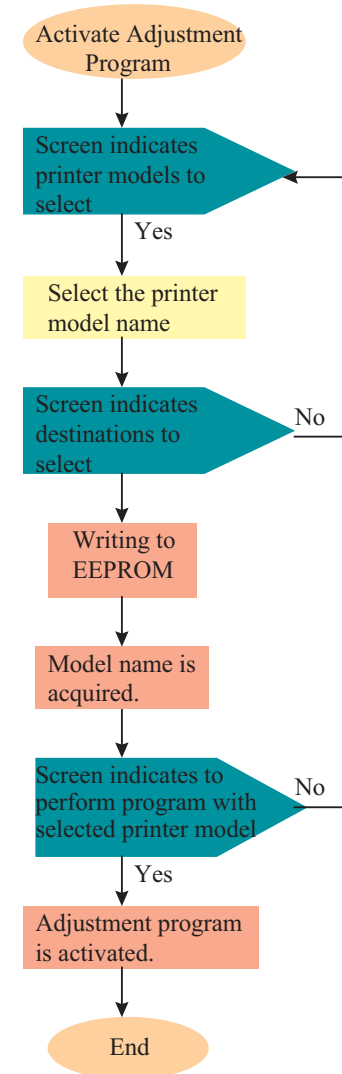

**Figure 5-1. Flow Chart**

## 5.2 Adjustment Program

Exclusive adjustment program is necessary in this section. This interface improved user interface and became easier to use than the previous programs. Comparing with the adjustment of Stylus Photo750, only modified or changed points are explained here.

### 5.2.1 Activation of Program

1. Turn off both printer and host computer, and connect them with parallel interface cable.
2. Turn on the printer and host computer.
3. Make a folder in the host computer and save the file of adjustment program in that folder. Or, insert the disk of the adjustment program into the disk drive.
4. Run the program on the DOS Prompt of the Windows. The following screen (See Figure 5-2) will appear.
5. Select "Stylus Photo 1200" by using  $\uparrow\downarrow$  key and press "Enter" key. Then, the screen for destination (See Figure 5-3) will appear.

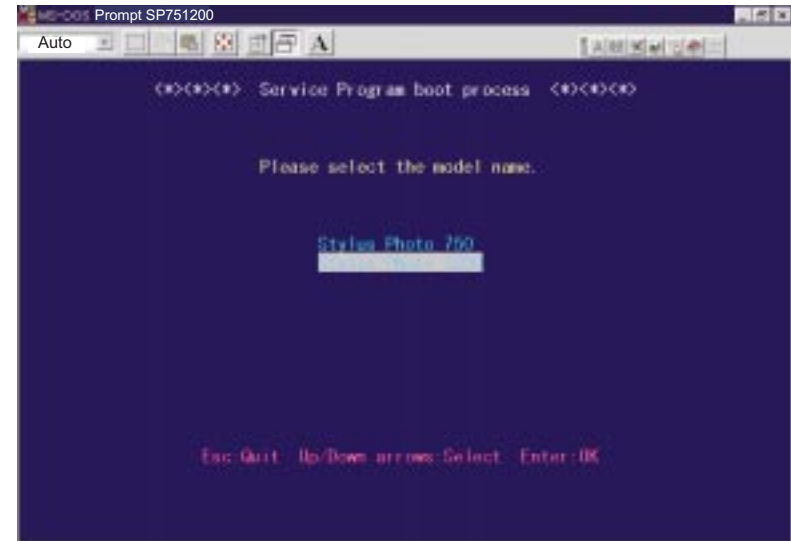

Figure 5-2. First Screen of Adjustment Program

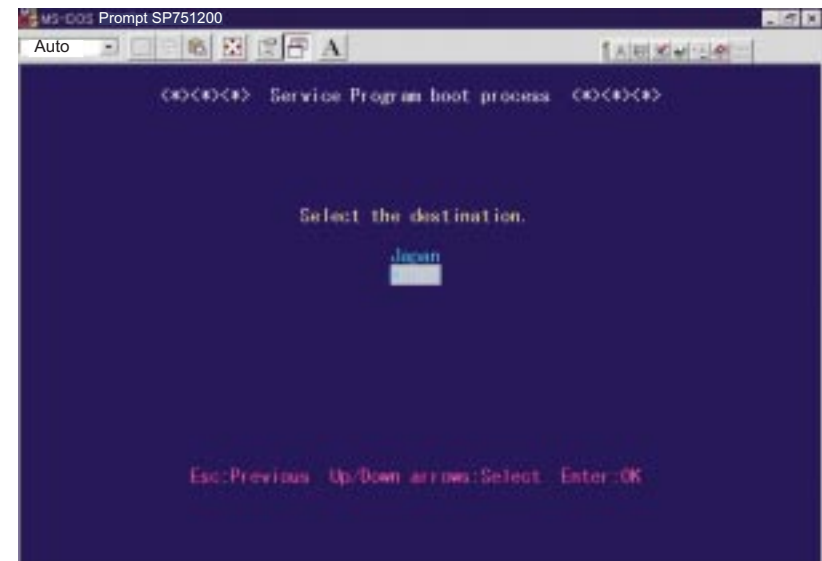

Figure 5-3. Destination Selection

6. Select "World" and press "Enter" key. The screen like figure 5-4 will appear.
7. Select "Perform (Boot this PROGRAM)". Refer to the Service Manual of Stylus Photo 750 for the rest of adjustment procedures.

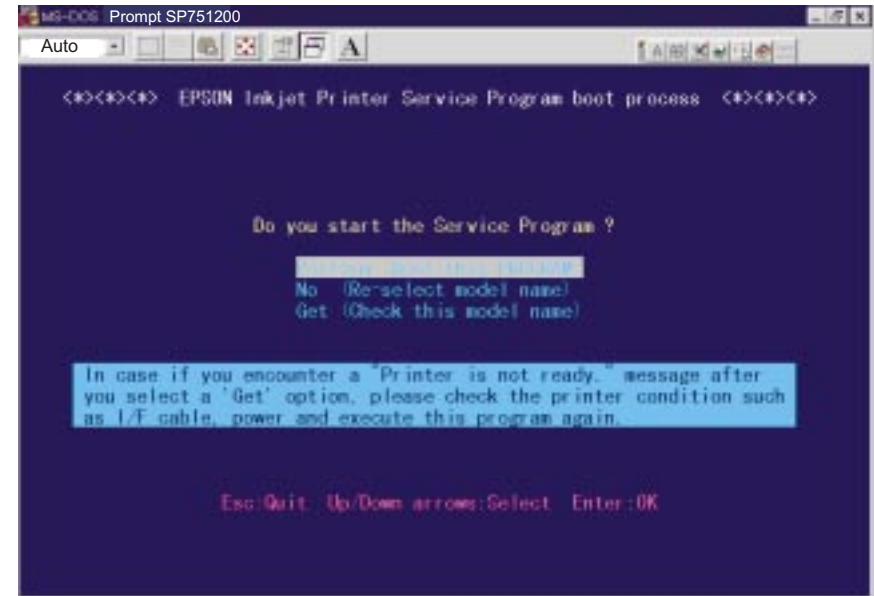

Figure 5-4. Starting the Program

**CHAPTER**

**6**

**MAINTENANCE**

Since the basic component of EPSON Stylus Photo 1200 is same as that of EPSON Stylus Photo750, refer to the Service Manual of EPSON Stylus Photo 750 for maintenance.

**CHAPTER**

**7**

**APPENDIX**

# 7.1 Exploded Diagram

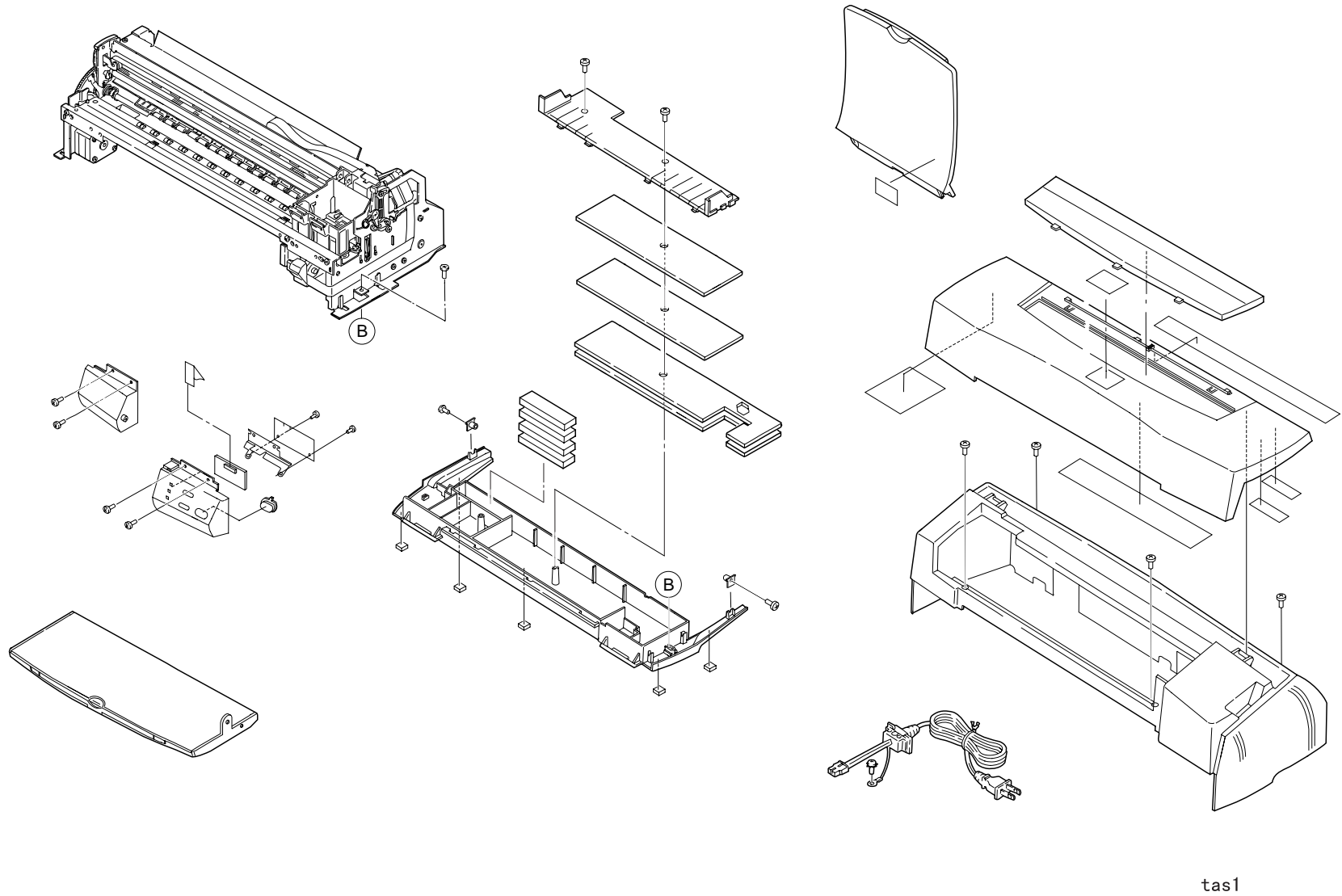
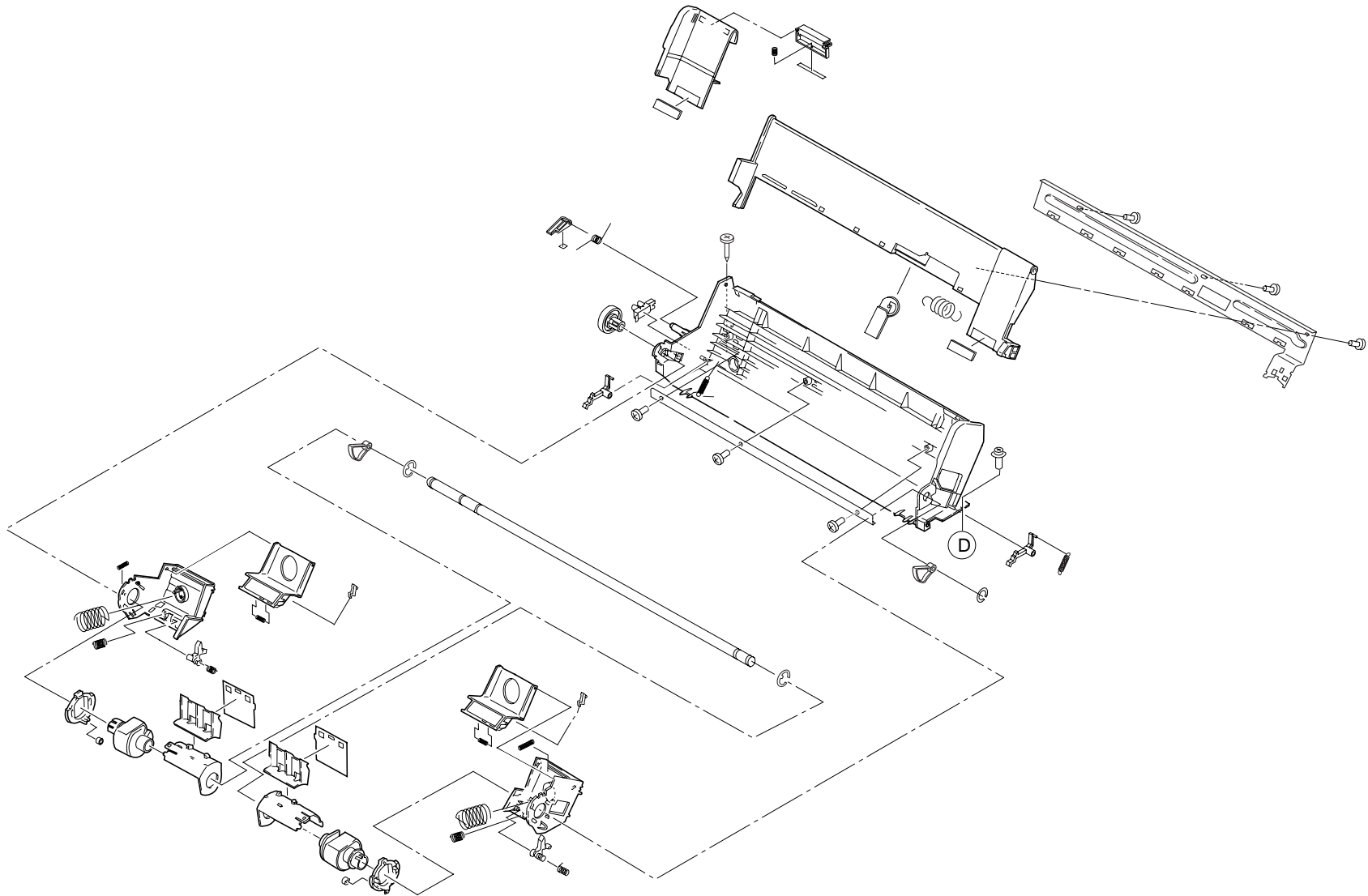
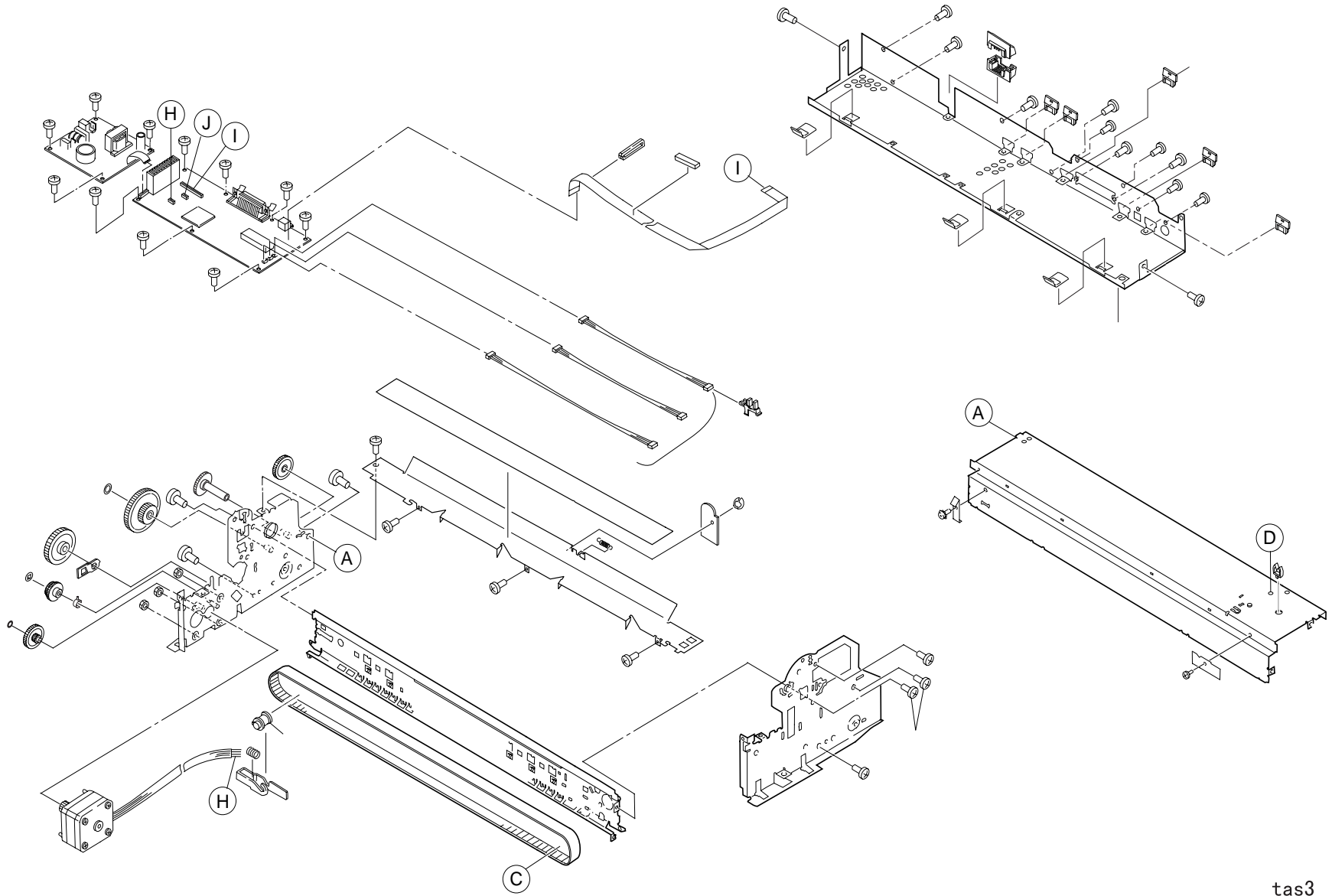

Figure 7-1. Exploded Diagram (1)



tas2

Figure 7-2. Exploded Diagram(2)



tas3

Figure 7-3. Exploded Diagram(3)

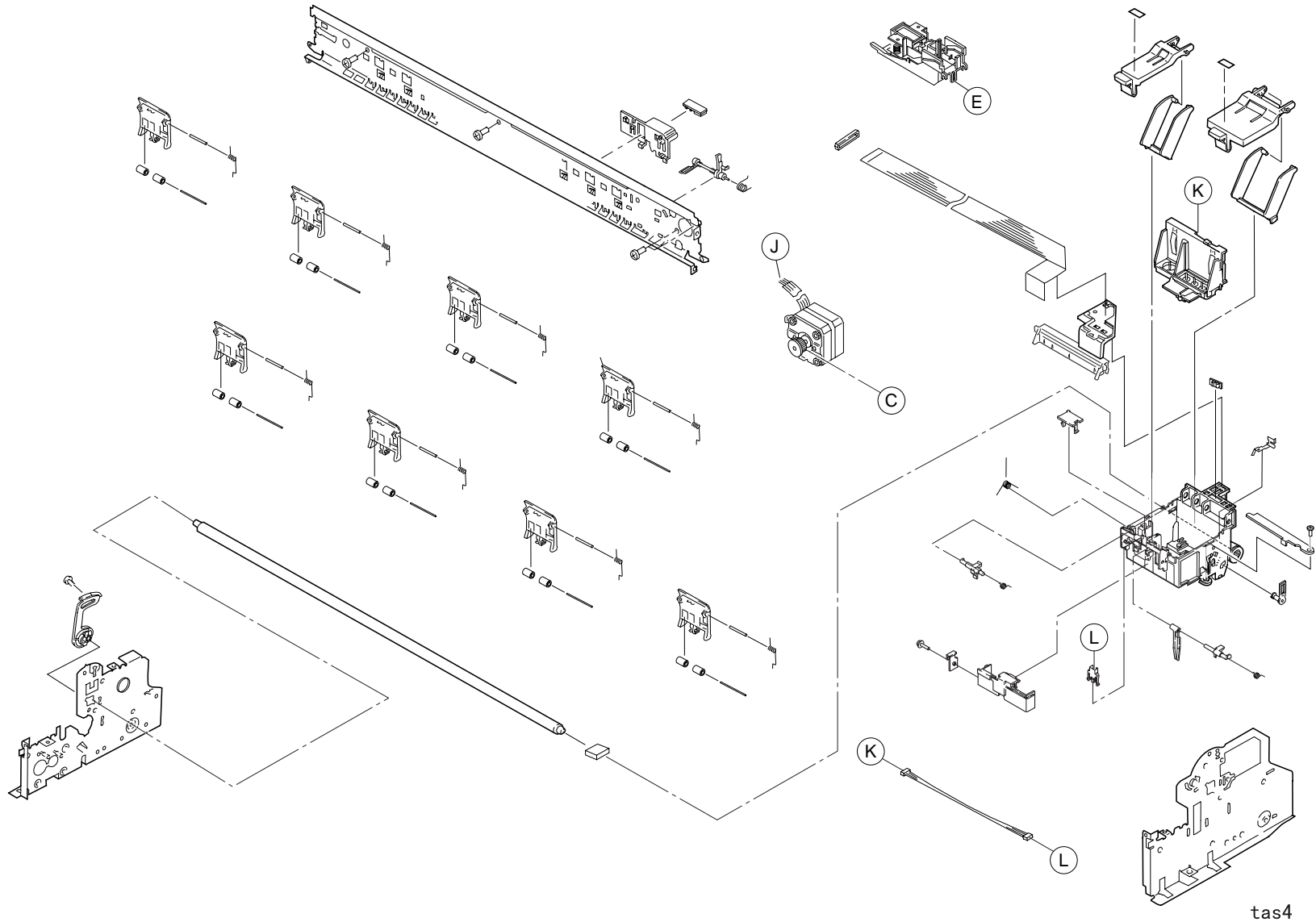
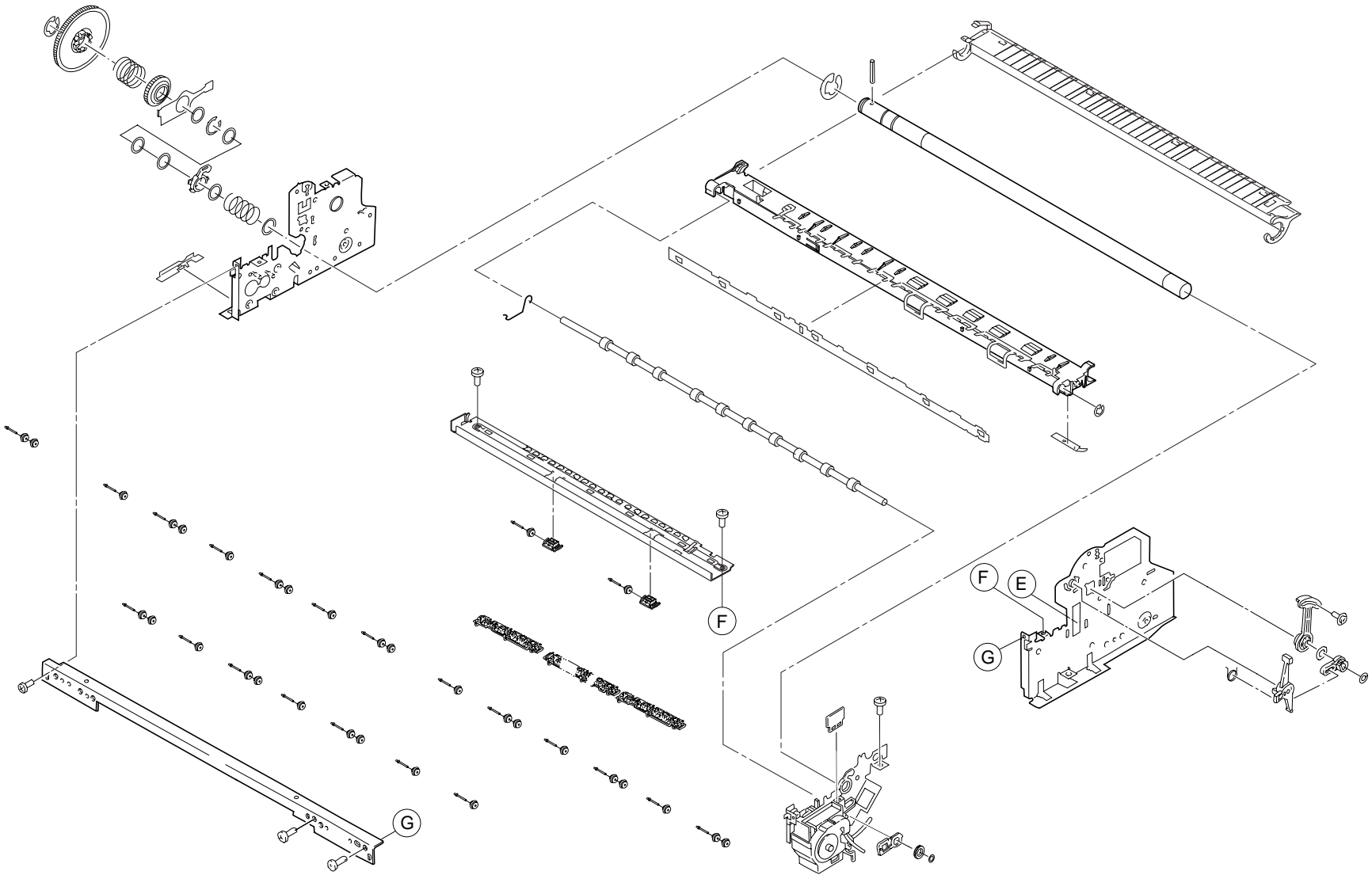

Figure 7-4. Exploded Diagram (4)



tas5

Figure 7-5. Exploded Diagram (5)



## 7.2 Circuit Boards

---

There are 2 kinds of main boards for this printer; C259 Main Board and C264 Main Board. C259 Main Board and C257 PSB Power Supply Circuit are used for Stylus Photo750. C206 PNL Control Panel Board is common with Stylus Color400 and Stylus Photo EX.

Therefore, refer to the corresponding Service Manual for each circuit diagram.



**C259 Main Board and C264 Main Board have same circuit and pattern. However, the connector shape with other elements is different, be careful of its selection.**