

SERVICE MANUAL

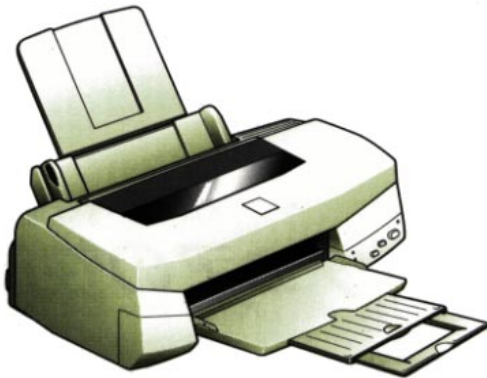

Photo Ink Jet Printer

EPSON Stylus Color 700

EPSON Stylus Color EX



EPSON®

NOTICE

- All rights reserved. No part of this manual may be reproduced, stored in a retrieval system, or transmitted in any form or by any means, electronic, mechanical, photocopying, recording, or otherwise, without the prior written permission of SEIKO EPSON CORPORATION.
- The contents of this manual are subject to change without notice.
- All effort have been made to ensure the accuracy of the contents of this manual. However, should any errors be detected, SEIKO EPSON would greatly appreciate being informed of them.
- The above notwithstanding SEIKO EPSON CORPORATION can assume no responsibility for any errors in this manual or the consequences thereof.

EPSON is a registered trademark of SEIKO EPSON CORPORATION.

General Notice: Other product names used herein are for identification purpose only and may be trademarks or registered trademarks of their respective owners. EPSON disclaims any and all rights in those marks.

Copyright © 1996 SEIKO EPSON CORPORATION. Printed in Japan.

PRECAUTIONS

Precautionary notations throughout the text are categorized relative to 1) Personal injury and 2) damage to equipment.

DANGER Signals a precaution which, if ignored, could result in serious or fatal personal injury. Great caution should be exercised in performing procedures preceded by DANGER Headings.

WARNING Signals a precaution which, if ignored, could result in damage to equipment.

The precautionary measures itemized below should always be observed when performing repair/maintenance procedures.

DANGER

1. ALWAYS DISCONNECT THE PRODUCT FROM THE POWER SOURCE AND PERIPHERAL DEVICES PERFORMING ANY MAINTENANCE OR REPAIR PROCEDURES.
2. NOWORK SHOULD BE PERFORMED ON THE UNIT BY PERSONS UNFAMILIER WITH BASIC SAFETY MEASURES AS DICTATED FOR ALL ELECTRONICS TECHNICIANS IN THEIR LINE OF WORK.
3. WHEN PERFORMING TESTING AS DICTATED WITHIN THIS MANUAL, DO NOT CONNECT THE UNIT TO A POWER SOURCE UNTIL INSTRUCTED TO DO SO. WHEN THE POWER SUPPLY CABLE MUST BE CONNECTED, USE EXTREME CAUTION IN WORKING ON POWER SUPPLY AND OTHER ELECTRONIC COMPONENTS.

WARNING

1. REPAIRS ON EPSON PRODUCT SHOULD BE PERFORMED ONLY BY AN EPSON CERTIFIED REPAIR TECHNICIAN.
2. MAKE CERTAIN THAT THE SOURCE VOLTAGES IS THE SAME AS THE RATED VOLTAGE, LISTED ON THE SERIAL NUMBER/RATING PLATE. IF THE EPSON PRODUCT HAS A PRIMARY AC RATING DIFFERENT FROM AVAILABLE POWER SOURCE, DO NOT CONNECT IT TO THE POWER SOURCE.
3. ALWAYS VERIFY THAT THE EPSON PRODUCT HAS BEEN DISCONNECTED FROM THE POWER SOURCE BEFORE REMOVING OR REPLACING PRINTED CIRCUIT BOARDS AND/OR INDIVIDUAL CHIPS.
4. IN ORDER TO PROTECT SENSITIVE MICROPROCESSORS AND CIRCUITRY, USE STATIC DISCHARGE EQUIPMENT, SUCH AS ANTI-STATIC WRIST STRAPS, WHEN ACCESSING INTERNAL COMPONENTS.
5. REPLACE MALFUNCTIONING COMPONENTS ONLY WITH THOSE COMPONENTS BY THE MANUFACTURE; INTRODUCTION OF SECOND-SOURCE ICs OR OTHER NONAPPROVED COMPONENTS MAY DAMAGE THE PRODUCT AND VOID ANY APPLICABLE EPSON WARRANTY.

PREFACE

This manual describes basic functions, theory of electrical and mechanical operations, maintenance and repair procedures of EPSON Stylus Photo 700 and EPSON Stylus Photo EX. The instructions and procedures included herein are intended for the experienced repair technicians, and attention should be given to the precautions on the preceding page. The chapters are organized as follows:

CHAPTER 1. PRODUCT DESCRIPTIONS

Provides a general overview and specifications of the product.

CHAPTER 2. OPERATING PRINCIPLES

Describes the theory of electrical and mechanical operations of the product.

CHAPTER 3. TROUBLESHOOTING

Provides the step-by-step procedures for troubleshooting.

CHAPTER 4. DISASSEMBLY AND ASSEMBLY

Describes the step-by-step procedures for disassembling and assembling the product.

CHAPTER 5. ADJUSTMENTS

Provides Epson-approved methods for adjustment.

CHAPTER 6. MAINTENANCE

Provides preventive maintenance procedures and the lists of Epson-approved lubricants and adhesives required for servicing the product.

APPENDIX

Provides the following additional information for reference:

- Connector pin assignments
- Electric circuit boards components layout
- Exploded diagram
- Electrical circuit boards schematics

TABLE OF CONTENTS

PRODUCT DESCRIPTIONS

1.1 OVERVIEW	1-1
1.1.1 Features.....	1-1

OPERATING PRINCIPLES

2.1 OVERVIEW	2-1
2.1.1 Printer Mechanism	2-1
2.1.1.1 Printhead Unit	2-1
2.1.2 Electrical Circuit	2-3

DISASSEMBLY AND ASSEMBLY

3.1 OVERVIEW	3-1
3.1.1 C233MAIN board removal for EPSON Stylus Photo 700	3-1
3.1.2 Caution for removing Printhead on EPSON Stylus Photo 700	3-2

ADJUSTMENT

4.1 OVERVIEW	4-1
4.1.1 Printhead ID Input.....	4-1

TROUBLESHOOTINGS

MAINTENANCE

6.1 OVERVIEW	6-1
6.1.1 Lubrication	6-1

APPENDIX

7.1 OVERVIEW	7-1
7.1.1 Connector Pin Assignment.....	7-1
7.2 CIRCUIT DIAGRAM	7-3

CHAPTER

1

PRODUCT DESCRIPTIONS

1.1 OVERVIEW

EPSON Stylus Photo 700 and EPSON Stylus Photo EX are photo-quality color printers developed based on EPSON Stylus Photo. Since most of functionality and operations of these printers are the same with EPSON Stylus Photo, this manual only describes the difference, and any other information not described in this manual should be referred to EPSON Stylus Photo service manual.

1.1.1 Features

The main feature and the specification of EPSON Stylus Photo 700 and EPSON Stylus Photo EX are as follows:

Table 1-1. Feature Comparison

Features	EPSON Stylus Photo 700	EPSON Stylus Photo EX	EPSON Stylus Photo
Acceptable Paper Size	Up to A4/LTR/LGL	Up to A3/B4 <ul style="list-style-type: none"> ■ A3(297x420mm) ■ B4(257x364mm) 	Up to A4/LTR/LGL
Print Resolution (Max.)	1440 x 720 dpi	↩	720 x 720 dpi
Ink Droplet size	<ul style="list-style-type: none"> ■ Normal dot ■ Super-micro dot 	<ul style="list-style-type: none"> ■ Normal dot ■ Micro dot ■ Super-micro dot 	<ul style="list-style-type: none"> ■ Normal dot ■ Micro dot
Printhead	<ul style="list-style-type: none"> ■ One-Chip Head (Black+Color) ■ 32 nozzle / color (90dpi) 	<ul style="list-style-type: none"> ■ One-Chip Head (Black+Color) ■ 32 nozzle / color (90dpi) 	<ul style="list-style-type: none"> ■ One-Chip Head (Black+Color) ■ 32 nozzle / color (90dpi)
Ink cartridge	Black: S020093 Color: S020110	↩	↩
Serial I/F Baud rate (Mac Serial / RS-423)	Up to 1.8Mbps *1	Up to 900Kbps	↩
Electrical Circuit Boards	<ul style="list-style-type: none"> ■ Main C233MAIN ■ Power supply C206PSB/PSE ■ Control panel C209PNL 	<ul style="list-style-type: none"> ■ Main C231MAIN ■ Power supply C206PSB/PSE ■ Control panel C206PNL 	<ul style="list-style-type: none"> ■ Main C209MAIN ■ Power supply C206PSB/PSE ■ Control panel C209PNL

Note) *1: Applicable cable is Apple Mini-DIN 8-pin system peripheral-8 cable (#M0197LL/B).

CHAPTER

2

OPERATING PRINCIPLES

2.1 OVERVIEW

This section describes the difference in printer mechanism design and the electrical circuitry for EPSON Stylus Photo 700 / EX and EPSON Stylus Photo.

2.1.1 Printer Mechanism

The major difference between EPSON Stylus Photo 700 / EX and EPSON Stylus Photo are as follows:

Table 2-1. Printer Mechanism

Item	EPSON Stylus Photo EX	EPSON Stylus Photo 700	EPSON Stylus Photo
Printer Mechanism	Wide-carriage unit (Up to A3/B4)	Narrow-carriage unit (Up to A4/LTR/LGL)	Same as Stylus Photo 700
Printhead Unit	Type: R-S62P <ul style="list-style-type: none"> ■ Normal dot ■ Micro dot ■ Super-Micro dot 	Type: R4C163Q <ul style="list-style-type: none"> ■ Normal dot ■ Super-Micro dot 	Same as Stylus Photo EX
Print Resolution (Max.)	1440 x 720dpi	1440 x 720dpi	720 x 720dpi

2.1.1.1 Printhead Unit

The printhead unit used on these products are basically the same, except the following:

Table 2-2. Printhead Unit

Item	EPSON Stylus Photo EX	EPSON Stylus Photo 700	EPSON Stylus Photo
Printhead Type	R-S62P	R4C163Q	Same as Stylus Photo EX
Nozzle configuration	<ul style="list-style-type: none"> ■ 6 colors ■ 32 nozzle per color ■ 90dpi nozzle pitch 	↔	↔
Head ID	<u>6 digit ID code</u> (123456) 1: Normal dot drive voltage ID 2: Pause time ID 3: Super-micro dot drive voltage ID 4: Ink weight ratio ID (A/B nozzles) 5: Ink weight ratio ID (C/D nozzles) 6: Check ID Example: <i>S2OLIX</i>	↔	<u>5 digit ID code</u> (12345) 1/2: Normal dot drive voltage ID 3: Pause time ID 4/5: Micro dot drive voltage ID Example: <i>03204</i>
Number of Connector	1	2	Same as Stylus Photo EX
Ink Cartridge	<ul style="list-style-type: none"> ■ Black: S020093 ■ Color: S020110 	↔	↔

2.1.2 Electrical Circuit

The difference in electrical circuits for EPSON Stylus Photo 700 / EX and EPSON Stylus Photo are as follows:

Table 2-3. Electrical Circuits

Item	EPSON Stylus Photo EX	EPSON Stylus Photo 700	EPSON Stylus Photo
Main Board	C231MAIN (Circuitry is the same with C209MAIN for EPSON Stylus Photo)	C233MAIN	C209MAIN
Power Supply Unit	C206PSB/PSE	↔	↔
Control Panel	C206PNL (Same with EPSON Stylus Color 400/600)	C209PNL	↔

The circuitry of C233MAIN Board for EPSON Stylus Photo 700 is partly modified compared with C209MAIN/C231MAIN for EPSON Stylus Photo and Stylus Photo EX, and a figure below illustrates the circuit diagram of C233MAIN board.

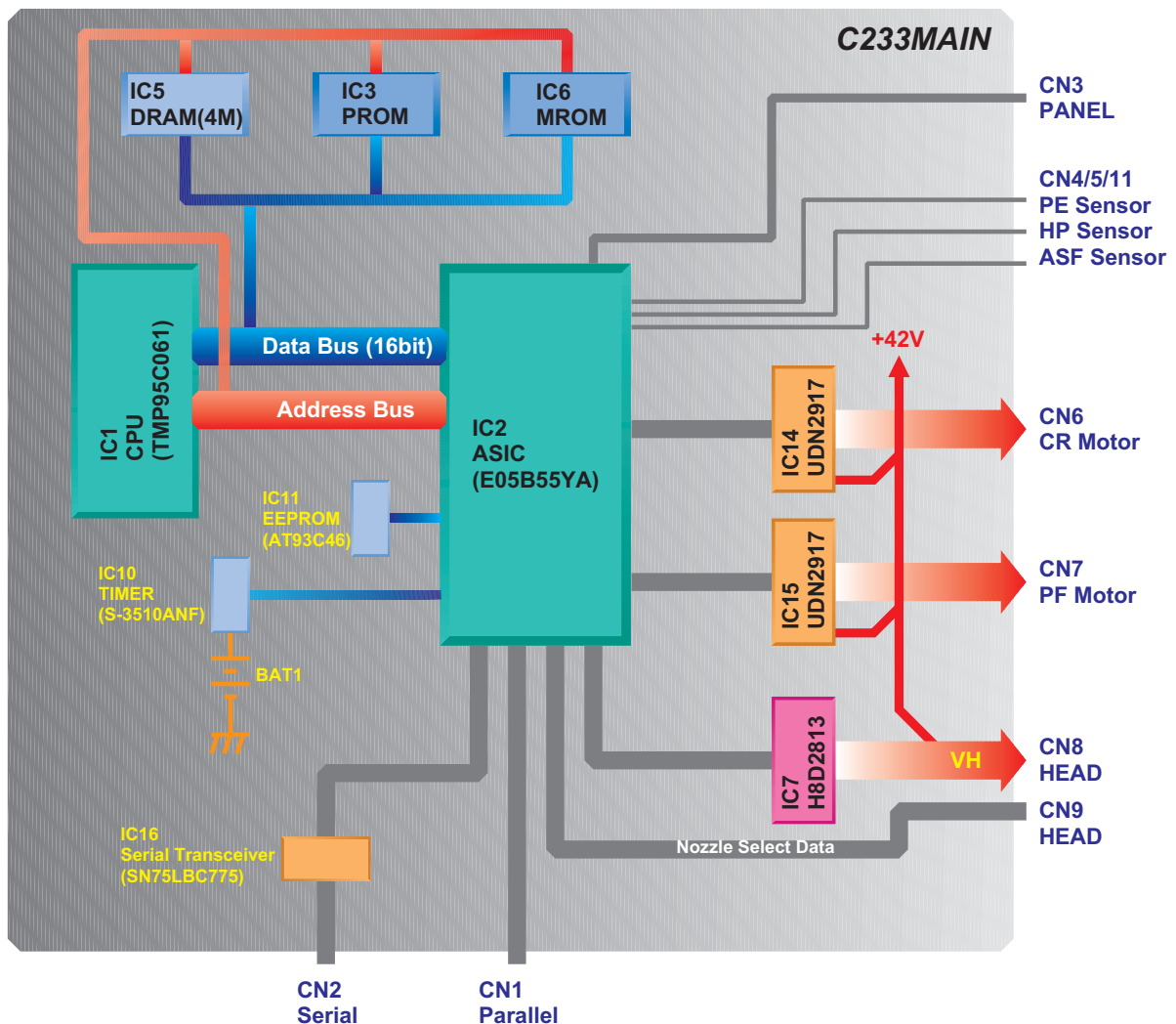

Figure 2-1. Circuit Block Diagram - C233MAIN Board

CHAPTER

3

DISASSEMBLY AND ASSEMBLY

3.1 OVERVIEW

Since the structure of printer mechanism and the connection between the mechanism and the electrical circuits are the same with EPSON Stylus Photo, disassembly and assembly of the unit can basically be made by referring to the procedures described in EPSON Stylus Photo Service manual.

The procedures described below are only applicable to EPSON Stylus Photo 700.

3.1.1 C233MAIN board removal for EPSON Stylus Photo 700

1. Housing removal. (refer to EPSON Stylus Photo Service manual / Chapter 3, Section 3.2.1)
2. "SHIELD PLATE, M/B" removal.
(refer to EPSON Stylus Photo Service manual / Chapter 3, Section 3.2.2)
3. After dismounting "SHIELD PLATE, M/B" from the printer, remove all cables from C233MAIN board.
4. Remove seven screws (4: fixing C233MAIN, 3: fixing C233MAIN from the outside of "SHIELD PLATE, M/B") and remove C233MAIN board.

Table 3-1. Cable Connection

Connector	Connected to
CN3	⇒Control panel (C209PNL)
CN4	⇒Printer mechanism (PE Sensor)
CN5	⇒Printer mechanism (HP Sensor)
CN6	⇒Printer mechanism (CR motor)
CN7	⇒Printer mechanism (PF motor)
CN8	⇒Printer mechanism (Printhead: VH, Nozzle select data)
CN9	⇒Printer mechanism (Printhead: Nozzle drive signals)
CN10	⇒Power supply unit (C206PSB/PSE)
CN11	⇒Printer mechanism (ASF Sensor)

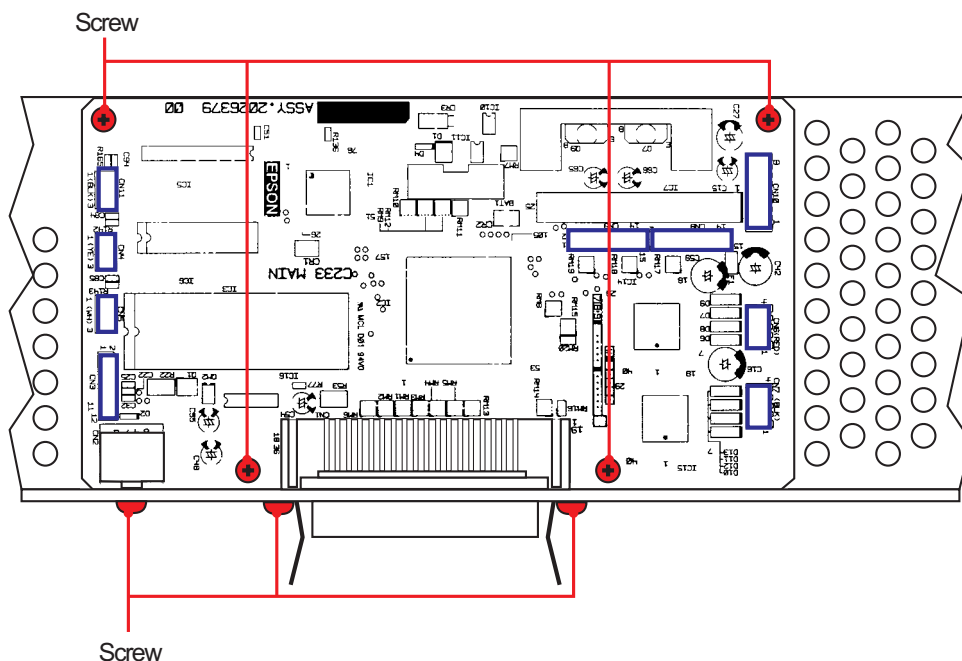

Figure 3-1. C233MAIN Removal

3.1.2 Caution for removing Printhead on EPSON Stylus Photo 700

There are two signal cables connected to the printhead of EPSON Stylus Photo 700 and both cables has the same number of terminal (15 terminals). Therefore, be careful with the cable connection either to the printhead or the main board (C233MAIN).

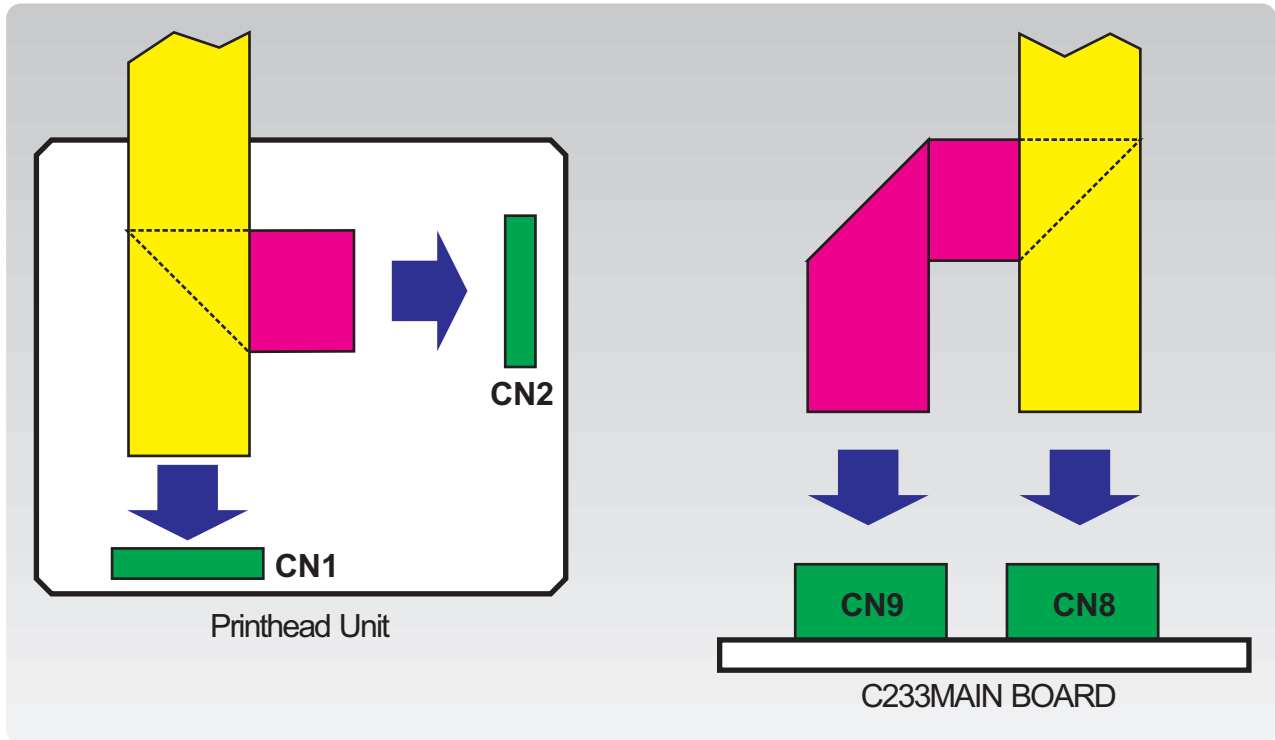

Figure 3-2. Cable Connection between Printhead and C233MAIN Board

CHAPTER

4

ADJUSTMENT

4.1 OVERVIEW

Since the adjustments required for EPSON Stylus Photo 700 and Stylus Photo EX is the same with the one for EPSON Stylus Photo, refer to the service manual (Chapter 4 Adjustment) of EPSON Stylus Photo for actual procedures.

4.1.1 Printhead ID Input

Since EPSON Stylus Photo 700 and Stylus Photo EX supports high resolution Super-micro dot printing, a unique ID number should be defined for EPSON Stylus Photo 700 and Stylus Photo EX.

When you perform the printhead ID input operation with the adjustment program, confirm the printhead ID number indicated on each printhead unit and input them with the program.

- For EPSON Stylus Photo 700 and Stylus Photo EX

Printhead ID: **6-digit number** (Example: S2OLIX)

- For EPSON Stylus Photo

Printhead ID: **5-digit number** (Example: 03204)

CHAPTER

5

TROUBLESHOOTINGS

Since the basic design and the structure of the printer mechanism and the electrical circuits are the same with EPSON Stylus Photo, refer to the service manual for EPSON Stylus Photo for detail.

CHAPTER

6

MAINTENANCE

6.1 OVERVIEW

The maintenance required for EPSON Stylus Photo 700 and Stylus Photo EX is the same with EPSON Stylus Photo, except the following. Follow the instruction below carefully when servicing EPSON Stylus Photo 700 and Stylus Photo EX.

6.1.1 Lubrication

The lubrication to the point described below is unique to EPSON Stylus Photo 700 and Stylus Photo EX.

CAUTION

- **Never use the oil and the grease other than those specified in this manual and using different type of lubricant can damage the printer and the components.**
- **Never apply oil or grease exceeding the amount specified in this manual.**

Table 6-1. Applicable Lubrication

Type	Name	EPSON Code	Supplier
Oil	O-12	1038991	EPSON

Table 6-2. Lubrication Point

No.	Lubrication Standard	Remarks
1	<p><Lubrication Point> Oil pad in the carriage assembly</p> <hr/> <p><Lubrication Type> O-12</p> <p><Lubrication Amount> 0.7cc <i>Note that this is an amount to be applied to brand-new oil pad when replacing it.</i></p>	<ul style="list-style-type: none"> ■ This lubrication must be made only when; “Replacing the carriage assembly” or “Replacing the oil pad” ■ Use a precise syringe to apply it. If accidentally apply too much oil to oil pad, thrown it away and take a new one again. ■ Leave oil pad for a while to wait until oil is evenly infiltrate and install it on the carriage assembly. <div style="text-align: center;"> </div>

CHAPTER

7

APPENDIX

A.1 OVERVIEW

Since the electrical circuit (Main board and power supply unit) of EPSON Stylus Photo EX is the same with EPSON Stylus Photo, this section only describes the main board: C233MAIN for EPSON Stylus Photo 700.

A.1.1 Connector Pin Assignment

Table A-1. Connector List - C233MAIN

Connector	Connected to	Table
CN1	Parallel I/F Connector	Refer to EPSON Stylus Photo Service manual
CN2	Serial I/F Connector	Refer to EPSON Stylus Photo Service manual
CN3	⇒Control panel (C209PNL)	Refer to EPSON Stylus Photo Service manual
CN4	⇒Printer mechanism (PE Sensor)	Refer to EPSON Stylus Photo Service manual
CN5	⇒Printer mechanism (HP Sensor)	Refer to EPSON Stylus Photo Service manual
CN6	⇒Printer mechanism (CR motor)	Refer to EPSON Stylus Photo Service manual
CN7	⇒Printer mechanism (PF motor)	Refer to EPSON Stylus Photo Service manual
CN8	⇒Printer mechanism (Printhead: VH, Nozzle select data)	Table A-2
CN9	⇒Printer mechanism (Printhead: Nozzle drive signals)	Table A-3
CN10	⇒Power supply unit (C206PSB/PSE)	Refer to EPSON Stylus Photo Service manual
CN11	⇒Printer mechanism (ASF Sensor)	Refer to EPSON Stylus Photo Service manual

Table A-2. Connector Pin Assignment - CN8

Pin	Signal Name	I/O	Fucntion
1	SI3	O	Head data output (3)
2	GND	-	Ground
3	CLK	O	Head data transfer clock signal
4	GND	-	Ground
5	LAT	O	Head data latch pulse
6	GND	-	Ground
7	VDD	-	+5V
8-10	GND2	-	Ground
11-13	COM	O	Head drive voltage
14-15	VHV	-	+42V

Table A-3. Connector Pin Assignment - CN9

Pin	Signal Name	I/O	Fucntion
1	GND	-	Ground
2	SI2	O	Head data output (2)
3	GND	-	Ground
4	SI1	O	Head data output (1)
5	GND	-	Ground
6	NCHG3	O	Head drive record control signal
7	GND	-	Ground
8	NCHG2	O	Head drive record control signal
9	GND	-	Ground
10	NCHG	O	Head all on pulse signal
11	GND	-	Ground
12	RESET	O	Drive record reset signal
13	COBC	I	Black ink cartridge detect singal H: No cartridge / L: Cartridge exist
14	COPC	I	Color ink cartridge detect signal H: No cartridge / L: Cartridge exist
15	THM	I	Thermistor output signal

A.2 CIRCUIT DIAGRAM

- ❑ EPSON Stylus Photo EX
Refer to EPSON Stylus Photo service manual (for Main board and Power supply unit)

- ❑ EPSON Stylus Photo 700
See next page for C233MAIN BOARD.

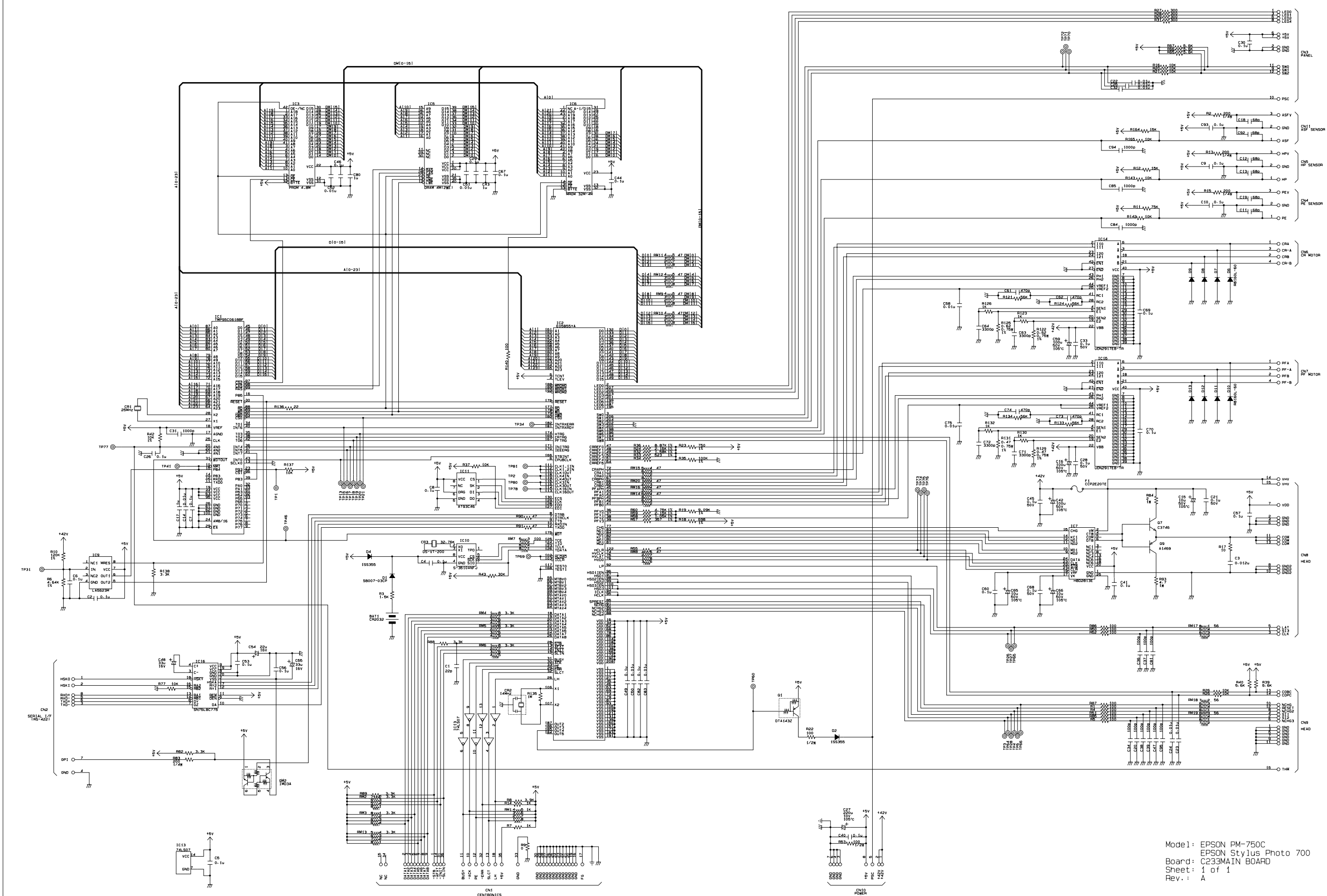

Model: EPSON PM-750C
 EPSON Stylus Photo 700
 Board: C233MAIN BOARD
 Sheet: 1 of 1
 Rev.: A