

EPSON

Color Ink Jet Printer

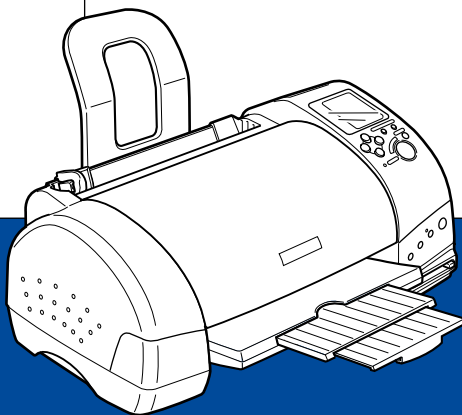

EPSON STYLUS™ PHOTO 915

Daily Use

4032203-00
EUL

Where to Find Information

Setup Guide

This guide will help you set up and begin using your printer. It includes information on setting up your printer and installing the printer software.

Photo Print Software Setup included on the CD-ROM

This guide provides information on installing EPSON PhotoQuicker, EPSON PhotoStarter and EPSON CardMonitor. It also contains uninstalling and system requirements.

Daily Use guide

This guide provides information mainly for direct printing. It also contains troubleshooting tips and customer support information. For printing with a computer, please refer to the *Online Reference Guide*.

EPSON PhotoQuicker User's Guide

Included on the printer software CD-ROM, this guide provides basic information on using the EPSON PhotoQuicker utility to print your photo data. It also contains troubleshooting tips.

Reference Guide included on the CD-ROM

The Reference Guide contained on the CD-ROM included with your printer provides detailed information about printer software settings, printing on special paper, maintenance, and problem solving.

To access the *Reference Guide*, refer to the *Setup Guide*.

All rights reserved. No part of this publication may be reproduced, stored in a retrieval system, or transmitted in any form or by any means, electronic, mechanical, photocopying, recording, or otherwise, without the prior written permission of SEIKO EPSON CORPORATION. The information contained herein is designed only for use with this EPSON printer. EPSON is not responsible for any use of this information as applied to other printers.

Neither SEIKO EPSON CORPORATION nor its affiliates shall be liable to the purchaser of this product or third parties for damages, losses, costs, or expenses incurred by the purchaser or third parties as a result of accident, misuse, or abuse of this product or unauthorized modifications, repairs, or alterations to this product, or (excluding the U.S.) failure to strictly comply with SEIKO EPSON CORPORATION's operating and maintenance instructions.

SEIKO EPSON CORPORATION shall not be liable for any damages or problems arising from the use of any options or any consumable products other than those designated as Original EPSON Products or EPSON Approved Products by SEIKO EPSON CORPORATION.

SEIKO EPSON CORPORATION shall not be held liable for any damage resulting from electromagnetic interference that occurs from the use of any interface cables other than those designated as EPSON Approved Products by SEIKO EPSON CORPORATION.

EPSON is a registered trademark and EPSON Stylus is a trademark of SEIKO EPSON CORPORATION.

Copyright 2001 SEIKO EPSON CORPORATION. All rights reserved. PRINT Image Matching is a trademark of SEIKO EPSON CORPORATION. The PRINT Image Matching logo is a trademark of SEIKO EPSON CORPORATION.

Microsoft and Windows are registered trademarks of Microsoft Corporation.

Apple and Macintosh are registered trademarks of Apple Computer, Inc.

DPOF is a trademark of CANON INC., Eastman Kodak Company, Fuji Photo Film Co., Ltd. and Matsushita Electric Industrial Co., Ltd.

SanDisk Host Developer's Tool Kit © 1999 SANDISK CORPORATION

General Notice: Other product names used herein are for identification purposes only and may be trademarks of their respective owners. EPSON disclaims any and all rights in those marks.

Copyright © 2002 by SEIKO EPSON CORPORATION, Nagano, Japan.



Printed on Recycled Paper.

Contents

Safety Instructions	1
Important Safety Instructions	1
Warnings, Cautions, and Notes	6
Printer Parts and Control Panel Functions	7
Printer Parts	7
Buttons	8
Lights	10
Using Roll Paper	11
Using the Roll Paper Holder	11
Removing Roll Paper from the Printer	17
Storing EPSON Roll Paper	18
Printing Photos Directly from PC Cards	19
Available Media Types	19
Loading Paper	22
Loading PC Cards	25
Printing from the Control Panel	30
Display	33
Printing All Photographs on a PC Card	37
Printing an Index Print	39
Printing a Selected Photo	41
Printing Multiple Selected Photos	43
Printing with the DPOF setting	45
Expanded Layout Options	46
Using Filters	52
Brightness Adjustment	54
Changing Default Settings	55
Replacing Ink Cartridges	57
Checking the Ink Supply	57

Replacing an Ink Cartridge	58
Maintenance	64
Checking the Print Head Nozzles	64
Cleaning the Print Head	65
Cleaning the Printer	67
Transporting the Printer	69
Troubleshooting	71
Error Indicators and Display	71
Print Quality Problems	74
Printout Problems Not Related to Print Quality	77
Paper Does Not Feed Correctly	78
Printer Does Not Print	81
Cancelling Printing	84
Exif Print	85
Printing with PRINT Image Matching	86
Customer Support	88
Technical Support Web Site	88
Contacting Customer Support	88
Options and Consumable Products	91
Options	91
Consumable products	93
Printer Specifications	95
Printing	95
Paper	95
Ink Cartridges	99
Mechanical	101
Electrical	101
Operating Environment	102
Standards and Approvals	102

Safety Instructions

Important Safety Instructions

Read all of the instructions in this section before using your printer. Also, be sure to follow all warnings and instructions marked on the printer.

When setting up your printer

Observe the following when setting up the printer:

- Do not block or cover the openings in the printer's cabinet.
- Use only the type of power source indicated on the printer's label.
- Be sure your AC power cord meets the relevant local safety standard.
- Connect all equipment to properly grounded power outlets. Avoid using outlets on the same circuit as photocopiers or air control systems that regularly switch on and off.
- Avoid electrical outlets controlled by wall switches or automatic timers.
- Keep the entire computer system away from potential sources of electromagnetic interference, such as loudspeakers or the base units of cordless telephones.
- Do not use a damaged or frayed power cord.

- ❑ If you use an extension cord with the printer, make sure that the total ampere rating of the devices plugged into the extension cord does not exceed the cord's ampere rating. Also, make sure that the total ampere rating of all devices plugged into the wall outlet does not exceed the wall outlet's ampere rating.
- ❑ Do not attempt to service the printer yourself.
- ❑ Unplug the printer and refer servicing to qualified service personnel under the following conditions:

The power cord or plug is damaged; liquid has entered the printer; the printer has been dropped or the cabinet damaged; the printer does not operate normally or exhibits a distinct change in performance.
- ❑ If you plan to use the printer in Germany, the building installation must be protected by a 10 or 16 amp circuit breaker to provide adequate short-circuit protection and over-current protection for this printer.

When choosing a place for the printer

Observe the following when choosing a place for the printer:

- ❑ Place the printer on a flat, stable surface that extends beyond the printer base in all directions. The printer will not operate properly if it is tilted or at an angle.
- ❑ Leave enough space in front of the printer for the paper to be fully ejected.
- ❑ Avoid places subject to rapid changes in temperature and humidity. Also, keep the printer away from direct sunlight, strong light, or heat sources.
- ❑ Avoid places subject to dust, shocks, and vibrations.

- ❑ Leave enough room around the printer to allow for sufficient ventilation.
- ❑ Place the printer near a wall outlet where the plug can be easily unplugged.

When using the printer

Observe the following when using the printer:

- ❑ Do not insert objects through the slots in the printer's cabinet.
- ❑ Take care not to spill liquid on the printer.
- ❑ Do not put your hand inside the printer or touch the ink cartridges during printing.
- ❑ Do not move the print head by hand; otherwise, you may damage the printer.
- ❑ Always turn the printer off using the  power button. When this button is pressed, the Processing light flashes briefly and then goes out. Do not unplug the printer or turn off the power to the outlet until the Processing light stops flashing.
- ❑ Before transporting the printer, make sure that the print head is in the home (far right) position and the ink cartridges are in place.

When using a memory card

- ❑ Do not remove the memory card or turn off the printer power while the computer and the memory card are communicating (when the Processing light is flashing). Doing so can corrupt memory card data.

- ❑ The handling method varies depending on the storage media. Be sure to refer to the documentation packaged with your memory card and PC card adapter for details.
- ❑ You can only use memory cards and PC card adapters that are based on PCMCIA ATA standards (Memory Card ATA standards) with this printer. For details about PCMCIA ATA standards, please see the manual packaged with your memory card or PC card adapter, or contact the manufacturer.

When using the display or the optional Preview Monitor

- ❑ Your LCD panel may contain a few small bright or dark spots. These are normal and do not mean that your LCD monitor is broken.
- ❑ Only use a dry, soft cloth to clean the display or the optional Preview Monitor. Do not use liquid or chemical cleansers.
- ❑ If the display on the printer or the Preview Monitor's LCD panel is damaged, contact your dealer. If the liquid crystal solution gets on your hands, wash them thoroughly with soap and water. If the liquid crystal solution gets into your eyes, flush them immediately with water. If discomfort or vision problems remain after a thorough flushing, see a physician immediately.
- ❑ Always attach the cover on the Preview Monitor slot, unless using the optional Preview Monitor.

When handling the ink cartridges

Observe the following when handling the ink cartridges:

- ❑ Keep ink cartridges out of the reach of children. Do not allow children to drink from or otherwise handle the cartridges.
- ❑ Be careful when you handle used ink cartridges, as there may be some ink remaining around the ink supply port. If ink gets on your skin, wash the area thoroughly with soap and water. If discomfort or vision problems remain after a thorough flushing, see a doctor immediately.
- ❑ Do not shake an ink cartridge; this can cause leakage.
- ❑ Install the ink cartridge immediately after you remove it from its package. Leaving the cartridge unpacked for a long time before use may result in reduced print quality.
- ❑ Do not use an ink cartridge beyond the date printed on the cartridge carton. For best results, use up the ink cartridges within six months of installing them.
- ❑ Do not dismantle the ink cartridges or try to refill them. This could damage the print head.
- ❑ After bringing an ink cartridge inside from a cold storage site, allow it to warm up at room temperature for at least three hours before using it.
- ❑ Store ink cartridges in a cool, dark place.
- ❑ Do not touch the green IC chip on the side of the cartridge. This may affect normal operation and printing.
- ❑ The IC chip on this ink cartridge retains a variety of cartridge related-information, such as the amount of ink remaining, so that a cartridge may be removed and reinserted freely. However, each time the cartridge is inserted, some ink is consumed because the printer automatically performs a reliability check.

- ❑ If you remove an ink cartridge for later use, protect the ink supply area from dirt and dust and store it in the same environment as the printer. A valve in the ink supply port makes covers or plugs unnecessary, but the ink may stain items that come in contact with this area of the cartridge. Do not touch the ink supply port or surrounding area.

ENERGY STAR® Compliance



As an ENERGY STAR® Partner, EPSON has determined that this product meets the ENERGY STAR® guidelines for energy efficiency.

The International ENERGY STAR® Office Equipment Program is a voluntary partnership with the computer and office equipment industry to promote the introduction of energy-efficient personal computers, monitors, printers, fax machines, copiers, and scanners in an effort to reduce air pollution caused by power generation.

Warnings, Cautions, and Notes



Warnings must be followed carefully to avoid bodily injury.



Cautions must be observed to avoid damage to your equipment.

Notes contain important information and useful tips on the operation of your printer.

Printer Parts and Control Panel Functions

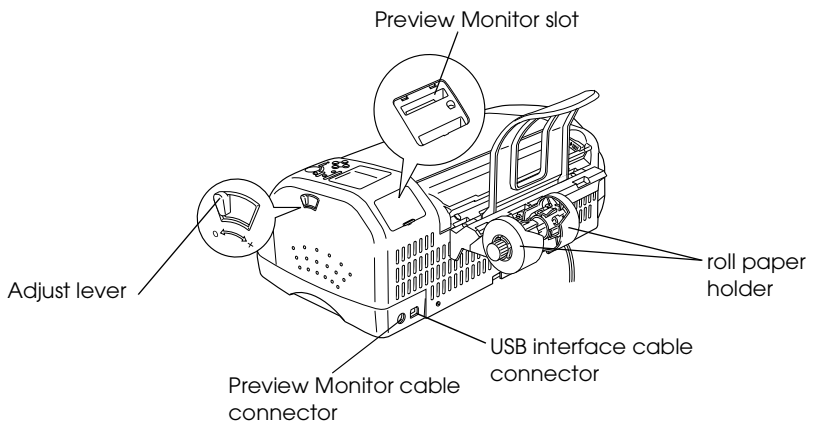
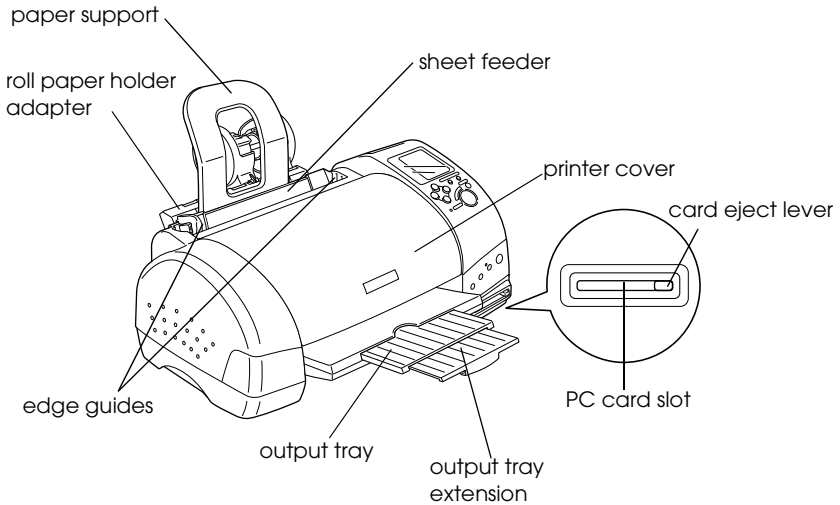

Printer Parts

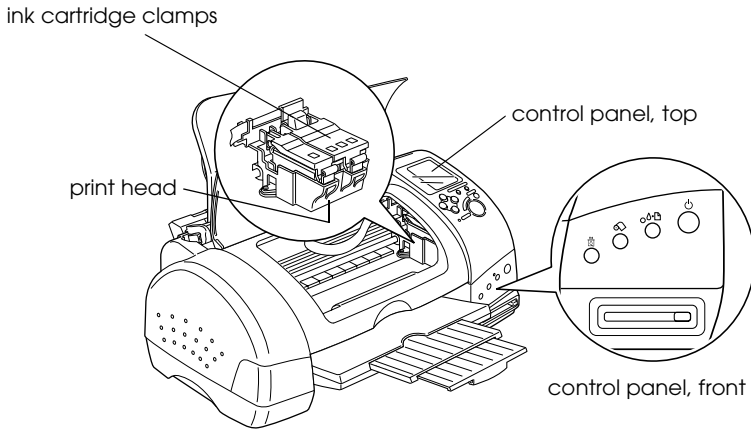





Buttons

Control panel, front

Button	Function
 power	Turns the printer on and off. Clears the printer's memory if pressed twice while the power is on.
 maintenance	Loads or ejects paper if pressed and released within two seconds. Resumes printing if pressed and released after a paper out error. Performs print head cleaning if pressed for 3 seconds while the  error light is off. Moves the print head to the ink cartridge replacement position and charges ink to the printer when ink is out.

 roll paper	Loads and ejects roll paper. Feeds roll paper in reverse to a position where it can be easily removed from the sheet feeder, if pressed for more than 3 seconds. Clears the  error light if pressed after removing roll paper.
 ink cartridge replacement	Moves the print head to the ink cartridge replacement position and charges ink to the printer when ink is out.

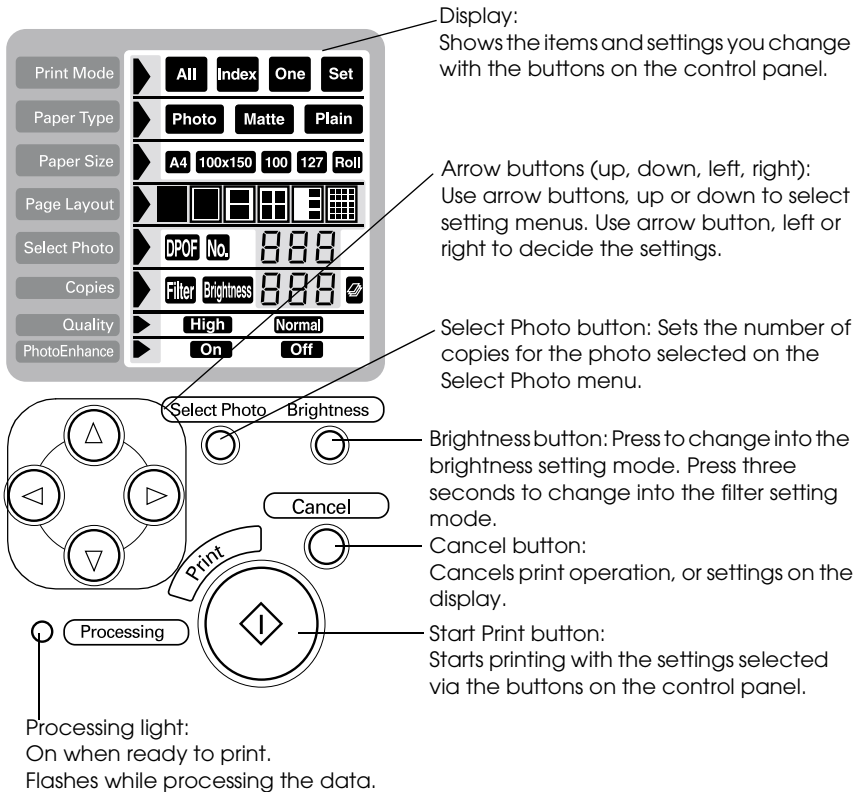

Control panel, top



Note:

The buttons on the top control panel only affect direct printing from a PC card.

Lights

Light	Description
Processing	<p>On when the printer is on.</p> <p>Flashes when the printer is receiving data, reading data from a PC card, sending PC card data to the computer, printing, charging ink, cleaning the print head, or when an ink cartridge is being replaced.</p>
 error	<p>On when the printer is out of paper. Load paper into the sheet feeder, then press the  maintenance button to resume printing.</p> <p>On when the paper is jammed. Take all of the paper out of the feeder, then reload it. If the light continues to flash, turn off the printer and gently pull all of the paper out of the printer.</p> <p>Flashes when the black or color ink cartridge is nearly empty.</p> <p>On when the black or color ink cartridge is empty. Replace the empty black ink cartridge or color ink cartridge.</p> <p>Black: T007 Standard Capacity T010 Light Capacity</p> <p>Color: T008</p> <p>Flashes when the print head has moved to the ink cartridge replacement position.</p>

Using Roll Paper

Using the Roll Paper Holder

With the roll paper holder mounted on the printer, you can print in roll paper format, which is convenient for banner printing. When you are printing using the roll paper holder, keep the following in mind:

- ❑ Load the paper printable side up.
- ❑ Use flat, undamaged paper. If the paper is curled, flatten it before loading to avoid paper feeding problems.
- ❑ Always handle the paper by the edges.
- ❑ Provide ample space in front of the printer for the paper to eject fully.
- ❑ Make sure that the output tray is down and the output tray extension is closed.
- ❑ Check that the end of the paper is cut cleanly, perpendicular to the long axis of the paper. If it is cut on a diagonal or not cleanly, the paper may not feed smoothly or the print may extend off the edge of the paper.
- ❑ EPSON recommends using media distributed by EPSON to ensure high-quality results.

Loading the roll paper

Follow the directions below to mount the roll paper holder and load the following types of roll paper.

Photo Paper (100 mm × 8 m)

Photo Paper (210 mm × 10 m)

Premium Glossy Photo Paper (100 mm × 8 m)

Premium Glossy Photo Paper (127 mm × 8 m)

Premium Glossy Photo Paper (210 mm × 10 m)

1. Load roll paper in the roll paper holder.

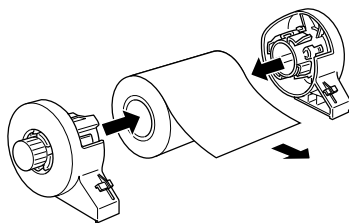

Note:

Remove the transparent sheet after setting the roll paper into the holders.

2. Check that the end of the roll is cut perpendicularly to the edges as shown, using a triangle.

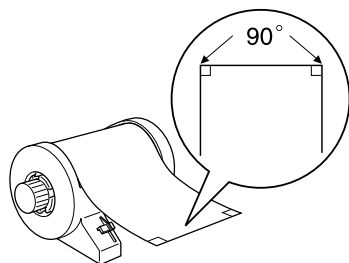



Caution:

Always use a triangle or other tool to ensure that the end of the roll is cut perpendicularly. A diagonal cut may cause paper feed problems.

3. To flatten the roll paper, place it printable-side up between the pages of the instruction booklet packaged with the roll paper to protect it. Then, roll the booklet in the direction opposite of the paper's curl.

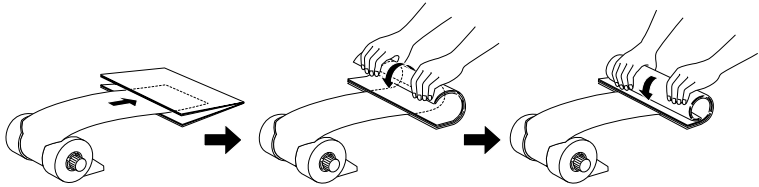

4. Remove the paper support and lower the output tray. Then turn on the printer.

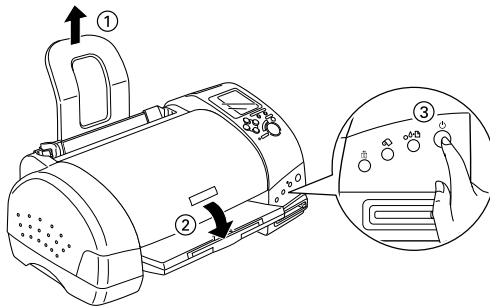

5. Insert the roll paper holder adapter into the slot at the rear of the printer, then attach the roll paper holder to the adapter.

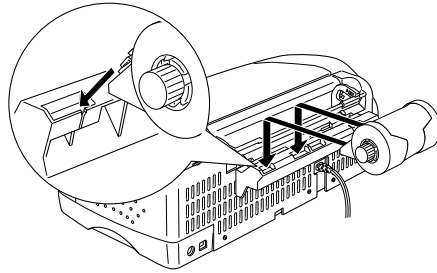

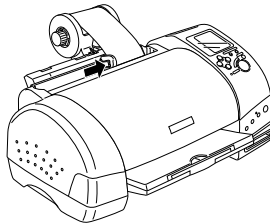

6. Gently insert the end of the paper into the printers as far as it will go, flush with the right edge guide. Slide the left edge guide against the left edge of the printer.

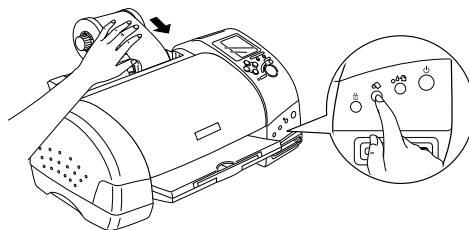

7. To load the paper correctly, you must hold the paper in place with your hand while you press the  roll paper button. The paper will feed into the printer.



8. Open the printer cover and make sure that the paper is feeding correctly. If it is not straight, press the  roll paper button for at least three seconds to eject the paper. The error light comes on. Press the  roll paper button to clear the error, then feed the paper again.

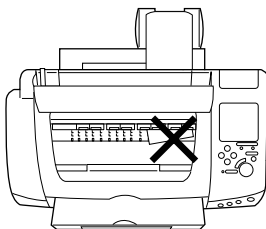

The roll paper is now loaded.



Note:

- Always check the ink levels before printing on roll paper as replacing ink cartridges while the roll paper is loaded can smear the paper.*
- We recommend replacing the roll paper with a new roll when there is 20 cm remaining. Otherwise, print quality may be compromised on the remaining portion.*
- Do not select A4 or 100 × 150 mm sheet paper for the Paper Size setting when roll paper is loaded in the sheet feeder. Doing so causes unnecessary paper to be fed after each print job. If you have already started printing, press the CANCEL button. Wait until the printer stops printing and feeding paper. Cut off the paper at the back of the printer, then turn off the printer. The remaining paper is ejected.*

Printing area and margins

Follow the steps below to change the margins between pages of printed data.

1. Select Roll Paper as the Paper Size on the control panel, top.

- When printing is finished, press the  roll paper button once to print a cutting guideline about 12 mm from the bottom of the print data.
- To print the next print job, press the  roll paper button to feed the paper back to the printing position. Then start the next print job. The space between pages is automatically set to 36 mm, as shown below.

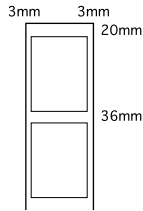

Standard margins

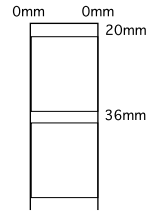

No margins



Note:

You must press the  roll paper button, or the printer will not operate even if you send a new print job. Do not press the  roll paper button more than necessary. Doing so can damage the printhead.

To print data with no margins between separate files, as shown below, do not press the  roll paper button between print jobs.

Standard margins

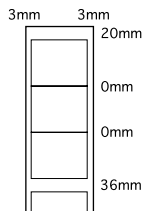

No margins

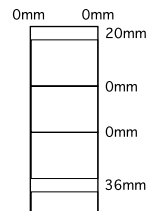

Note:

The top margin is automatically set to 20 mm, regardless of the margin setting.



Removing Roll Paper from the Printer

Follow the directions below to remove the paper from the printer.

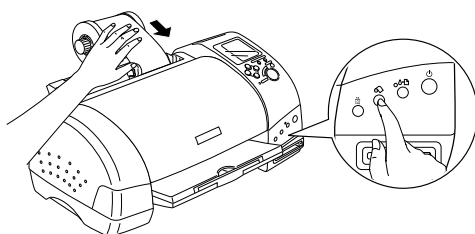
1. Press the  roll paper button to feed the paper. A cutting guide line is printed on the roll paper.



Note:

To cancel the paper removal sequence and print more data, press the  roll paper button and send the next print job. The paper will return to the printing start position before starting the next print job. Do not press the  roll paper button more than necessary. Doing so can damage the printout.

2. Cut the paper along the printed line. Never pull the paper as you cut it. Doing so may damage the printout. When cutting the paper, do not cut inside the line (closer to the printer) as this may cause paper feed problems.

Note:

EPSON recommends that you use a triangle or other tool to ensure that the end of the roll is cut perpendicularly. A diagonal cut may cause paper feed problems.

3. Once you have cut the paper, hold down the  roll paper button for about 3 seconds. The paper feeds in reverse to a position where it can be easily removed from the sheet feeder at the back of the printer. If it does not feed to this position, repeat this step.

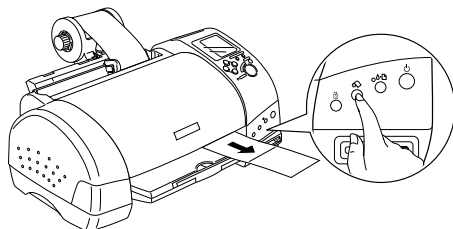

4. Gently remove the paper, then press the  roll paper button to clear error light.

Storing EPSON Roll Paper

Return unused paper to the original package as soon as you finish printing. EPSON recommends storing your printouts in a resealable plastic bag. Keep them away from high temperature, humidity, and direct sunlight.

Printing Photos Directly from PC Cards

Available Media Types

The type and quality of media determines the finish of your prints. Be sure to read the following information and select the correct paper for your needs.

Note:

- ❑ *You should always print at normal room temperature and humidity: 15 to 25°C (59 to 77°F) and 40 to 60% RH.*
- ❑ *Do not touch the printable surface of the media. Fingerprints may degrade in print quality.*

Plain paper (A4, 100 x 150 mm)

When using plain paper, please observe the following:

- ❑ Use paper of 64 to 90 g/m² weight and 0.08 to 0.11 inches thick.
- ❑ Load paper up to the arrow mark on the edge guides.

EPSON special media

EPSON provides special print media that is formulated for the ink used on EPSON ink jet printers. EPSON recommends you use media distributed by EPSON to ensure high-quality results. Before loading any media distributed by EPSON, read the instruction sheet packed with it and keep the following in mind:

Note:

- ❑ *More media types and sizes are available when you print images from a computer with the EPSON Stylus Photo 915 printer software.*
- ❑ *The availability of special media varies by country. For the latest information on available media, visit our regional customer service web site.*



Caution:

Use EPSON special media in a normal room environment (temperature and humidity) to obtain best results.

The following table lists available media types and sizes when printing directly from PC cards. Select the one best suited to your printing needs.

Media name	Size available	Product code	Characteristics
Premium Ink Jet Plain Paper	A4	S041214	EPSON plain paper for your everyday printings needs.
Bright White Ink Jet Paper	A4	S041442	Outstanding results for all your everyday printing needs.
Photo Paper	A4	S041140	This media gives you the highest quality printouts at moderate printing cost. The glossy surface provides you with a photo-like finish.
	100 × 150 mm	S041255	
	100 mm × 8 m	S041279	
	210 mm × 10 m	S041280	

Media name	Size available	Product code	Characteristics
Matte Paper-Heavyweight	A4	S041256 S041258 S041259	Bright white, ultra smooth coated paper. For photo quality color with a matte finish. Perfect for photographs, signs, crafts projects and much more.
Premium Glossy Photo Paper	A4	S041285 S041287 S041297	Borderless prints for glass frames and photo albums. Looks and feels like a real photograph.
	100 mm × 8 m	S041302 S041303	
	127 mm × 8 m	S041474	
	210 mm × 10 m	S041376 S041377	

About cleaning sheets

The cleaning sheet packaged with some special types of media cannot be used with the paper feeding mechanism in this printer. Forcing it into the printer could damage the paper feeding mechanism.

Precautions on paper storage

- Store paper flat where it is not exposed to high temperature, high humidity, or direct sunlight.
- Do not let the paper get wet.
- Keep unused paper in its original packaging and store it in a cool, dry place to preserve quality.

Loading Paper

Loading sheet paper

This section applies to the following paper types:

Plain Paper

Premium Ink Jet Plain Paper

Bright White Ink Jet Paper

Photo Paper

Matte Paper-Heavyweight

Premium Glossy Photo Paper

Note:

Read all instruction sheets packed with your EPSON special media before loading it in the printer.

1. Lower the output tray and slide out the extension.

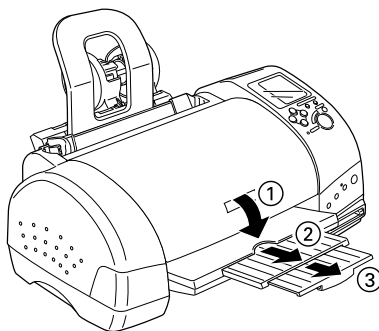

2. Fan a stack of paper; then tap it on a flat surface to even the edges.

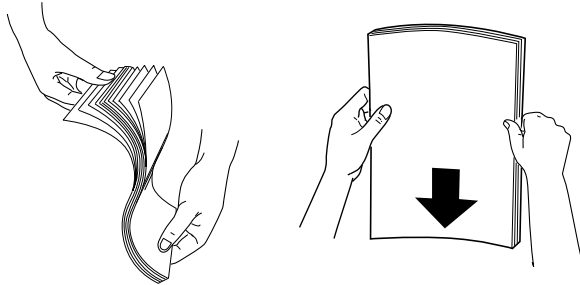

3. With the printable side up, load the paper so it is against the right edge guide, and slide it into the sheet feeder.

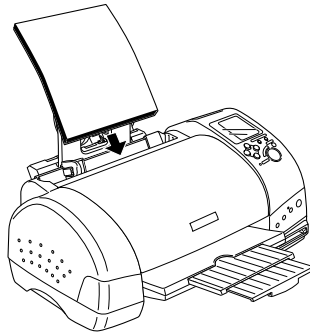

Paper	Loading Capacity
Plain paper	Up to arrow mark on the left edge guide
EPSON Photo Paper	Up to 20 Sheets
EPSON Matte Paper-Heavyweight	Up to 20 Sheets
EPSON Premium Glossy Photo Paper	One sheet at a time

4. Slide the left edge guide against the paper.

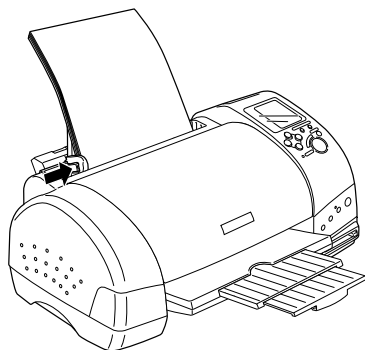

Note:

Be sure to make the left edge guide flush against the paper or the paper will not feed properly into the printer.

Loading EPSON Photo Stickers 16

To load EPSON Photo Stickers 16, follow the steps below.

Note:

Be sure to read the instruction sheet packed with the media before loading.

1. With the printable side up, set the media against the right edge guide and slide it into the sheet feeder.

Always load one sheet at a time in the feeder with the cut corner on the upper right side.

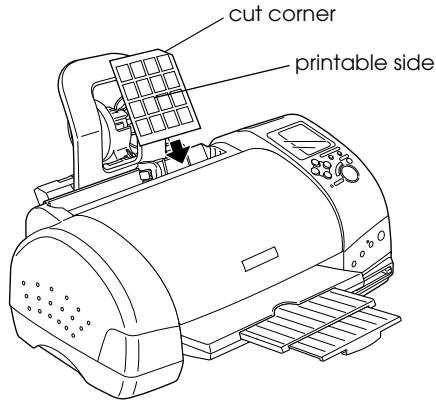

2. Slide the left edge guide against the edge of the media.

Note:

Set the left edge guide flush against the media or the media will not feed properly into the printer.

Loading PC Cards

Loadable storage media

Digital photographs are stored either in the digital camera's built-in memory or in card-type memory which can be inserted and removed from the camera. The latter is referred to as "storage media." The types of storage media that can be used with this printer are shown below.

Note:
appearance may vary.

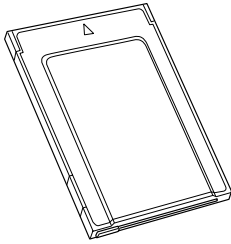

PC card (PCMCIA Type II)

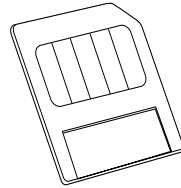

SmartMedia

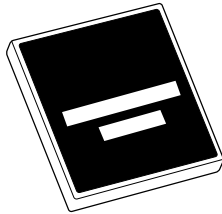

CompactFlash

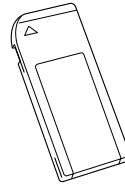

Memory Stick

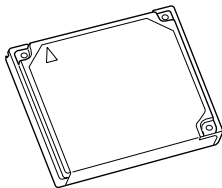

Microdrive

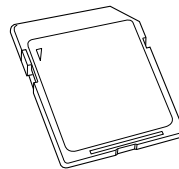

SD Memory Card



Caution:

- ❑ Always load any storage media other than a PC card into a PC card adapter before loading it into the PC card slot.
- ❑ The handling method varies depending on the storage media. Be sure to refer to the documentation packaged with your memory card and PC card adapter for details.

Note:

- ❑ Use the PC card adapter for CompactFlash packed with your printer. PC card adapters for SmartMedia, Memory Stick, Microdrive and SD Memory Card are sold separately.
- ❑ Not all storage media and PC card adapters are compatible with the EPSON Stylus Photo 915. Contact your EPSON dealer for detailed information on the compatibility of storage media and PC card adapters.

Loading PC cards

To load a PC card into the PC card slot, follow the steps below.

1. Insert the storage media into the PC card adapter as shown below.

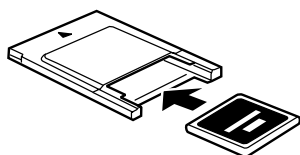

CompactFlash

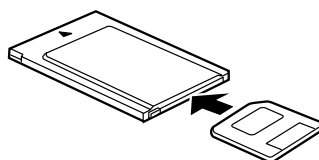

SmartMedia

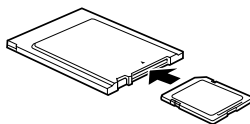

SD Memory Card

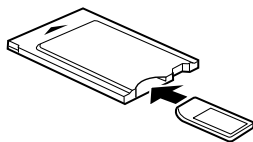

Memory Stick

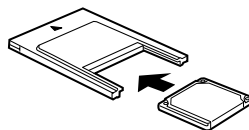

Microdrive



Caution:

The loading method varies depending on the storage media. Be sure to refer to the manuals packaged with your memory card and PC card adapter for details.

2. Load the PC card into the printer's card slot.

Load the card with the ▲ mark up. Be sure to insert the PC card as far as it will go so that the printer can read the data.

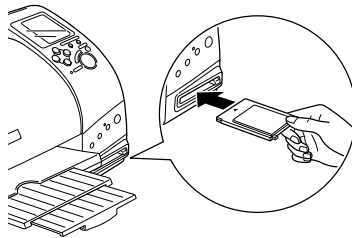

Caution:

- ❑ *Slide the PC card horizontally into the slot with the insert mark up. Forcing the card into the slot or inserting it at an angle can damage the printer and the card.*
- ❑ *Do not eject PC cards or turn off power to the printer while the printer is processing (reading or writing) data. Doing so can cause data to be lost.*

Ejecting PC cards

1. Check that the Processing light is not flashing.

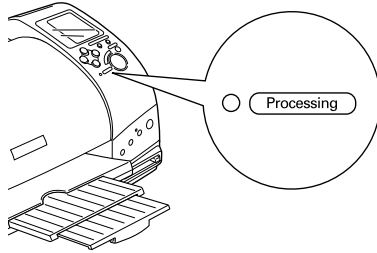

2. Press the button as shown to eject the PC card.

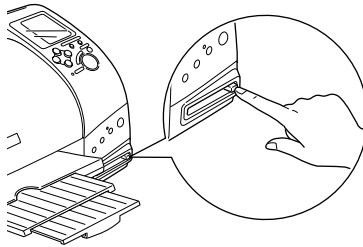

Caution:

- ❑ *Do not remove or insert CompactFlash, SmartMedia, Microdrive or SD memory card while the PC card adapter is in the slot. Doing so can cause data to be lost.*
- ❑ *The ejecting method varies depending on the storage media. Be sure to refer to the documentation packaged with your memory card and PC card adapter for details.*

3. The PC card will pop out far enough for you to pull it out.

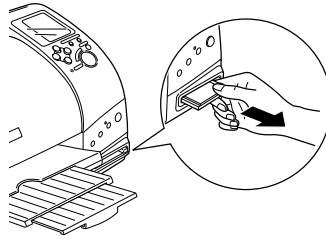

Printing from the Control Panel

This section briefly describes how to print from a PC card using the printer's control panel. Be sure to read and understand the instructions below before printing from a PC card.

Note:

- ❑ *Always test a few sheets of paper to make sure the print results before printing large jobs.*
- ❑ *We recommend disconnecting the USB cable when printing directly from PC card.*

Printing

1. Load paper and a PC card containing photo data in the printer.
2. Make print settings on the control panel using the arrow buttons.

Use the up and down arrow buttons to select menus.

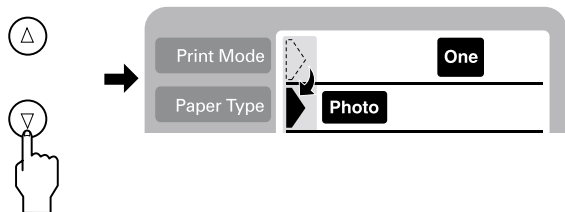

Use the right and left arrow buttons to select individual settings.

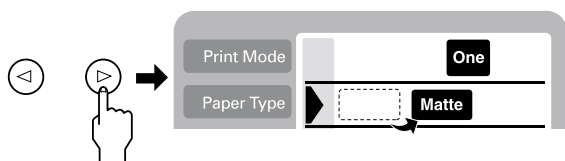

Note:

The photo numbering order may differ from your digital camera's settings. Always check the photo numbering by printing an Index. Index prints show photo information such as the photo number and the date. You can also check the photo number with the optional Preview Monitor.

3. Make sure the paper size is correct. If the roll paper icon appears on Paper Size menu, make sure that roll paper is loaded in the printer. If there is no roll paper icon, make sure that standard sheet paper is loaded. Press Start button to start printing.

Note:

When printing, Processing light flashes and Select Photo display rotates. Do not eject PC card during this process.

Cancelling printing

To stop printing in progress, press Cancel button. The printer will cancel all print jobs and stop printing, and eject any pages which is printing. Depending on the printer's status, printing may not stop immediately.

Data format

You can use image files that meet the following requirements with this printer.

Digital camera	Based on DCF version 1.0 standards*
File format	JPEG format image files taken with a DCF version 1.0 standard-compliant digital camera
Image size	Vertical 160 to 3200 pixels, horizontal 160 to 3200 pixels
Number of files	Up to 999 files on a memory card

* DCF stands for the "Design rule for Camera File system" standards, set by the Japan Electronics and Information Technology Industries Association (JEITA).

Note:

The file names containing double-byte characters are not valid when printing directly from a PC card.

Display

This section explains the Print Mode, Paper Type, Paper Size, Layout, Select Photo, Select Copies, Quality, and Photo Enhance settings.

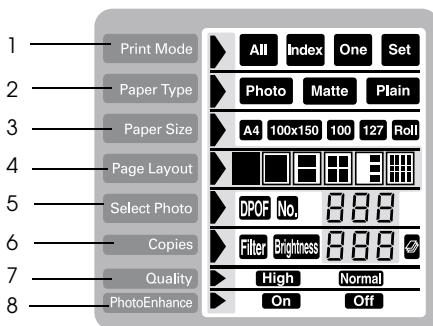

1. Print Mode

This selects the printing method.



Print all photographs on the PC card.



Print an index of all photographs on a PC card.



Print a single, selected photograph from the PC card.



Print selected photographs from the PC card.

2. Paper Type

This selects the type of paper to print on.

Photo Print on the Photo Paper.

Matte Print on the Matte paper-heavyweight.

Plain Print on the plain paper, Premium Ink Jet Plain Paper or Bright White Ink Jet Paper.

When you want to print on Premium Glossy Photo Paper, move cursor to Paper Type, then press the right arrow button for three seconds. "Pr" flashes on the Select Photo menu, and now you can print on the Premium Glossy Photo Paper. Press the left or right arrow buttons to exit.

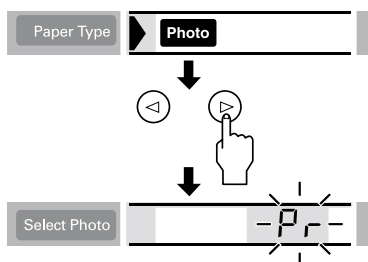

3. Paper Size

This selects the size of paper to print on.

A4 Print on A4 size (210 × 297 mm) of sheet paper

100x150 Print on 100 × 150 mm size of sheet paper

A4 **Roll** Print on 210 mm width of roll paper

100**Roll**

Print on 100 mm width of roll paper

127**Roll**

Print on 127 mm width of roll paper

Note:

Do not select A4 or 100 × 150 mm sheet paper for the Paper Size setting when roll paper is loaded in the sheet feeder. Doing so causes unnecessary paper to be fed after each print job. If you have already started printing, press the CANCEL button. Wait until the printer stops printing and feeding paper. Cut off the paper at the back of the printer, then turn off the printer. The remaining paper is ejected.

4. Select Layout

This selects the print layout. When printing more than one photograph on a sheet, you can select to print the same photograph every time or different photographs. The available settings depend on the size of the paper selected.



Print a photograph using the total surface area of the selected paper, or print on the roll paper with no left or right margins.



Print a photograph using the standard printable area of the selected paper with margins.



Print two photographs on the selected paper.



Print four photographs on the selected paper.



Print three photographs on the selected paper.



Print a photograph twenty times or twenty different photographs with the photo number, date, time or so on the selected paper. This layout is good for printing high quality index.

When printing on the total surface area of the selected paper, keep note the following.

- ❑ Printing with this setting selected takes longer than for normal printing.
- ❑ Because this setting enlarges the image to a size slightly larger than the paper size, the portion of the image that extends beyond the edges of the paper will not be printed.
- ❑ Print quality may decline in the top and bottom areas of the printout, or the area may be smeared when printing on the sheet paper.
- ❑ We recommend printing a single sheet to check quality before printing large jobs.

5. *Select Photo*

This specifies photo that you want to print by number when the printer is in One or Set mode. The total number of photographs on the PC card is displayed when the printer is in the All or Index mode.

Note:

The printer can handle up to 999 photo data files on a PC card.

6. *Copies*

This specifies the number of copies of selected photos to print, from 1 to 100 when the printer is in the All, One or Index mode. In the Set mode, you can specify the number of copies from 1 to 10.

7. Quality

This selects the photo print quality.

Note:

The Quality settings available depend on the Paper Type setting.

High Prints at high quality, but with reduced speed.

Normal Prints fast, saving ink. This setting is good for draft printing.

8. PhotoEnhance

Turns image enhancement on and off.

On Images imported from the PC card are automatically enhanced. Printing requires more time, but the image is enhanced to ensure higher picture quality.

Off Enhancement is off.

Printing All Photographs on a PC Card

You can print a specified number of copies of all of the photographs on a PC card. The instruction below show an example setting. For the other available setting options, see "Display" on page 33.

Note:

Before printing, load paper and a PC card containing digital photo data in the printer. See "Loading Paper" on page 22 and "Loading PC Cards" on page 25 for details.

1. Select ALL as the Print Mode setting.



2. Select the Paper Type that is loaded in the sheet feeder.

The example below shows printing on EPSON photo paper.



3. Select the Paper Size that is loaded in the sheet feeder.

The example below shows printing on A4-size paper.



4. Select the Page Layout setting you want.

The example below shows printing with no margins. For details on the settings, see “Display” on page 33.



Note:

The Photo No. setting in the Select Photo menu is not available when ALL is selected for the Print Mode.

5. Select the number of copies to print.

The example below is two copies of each photo.

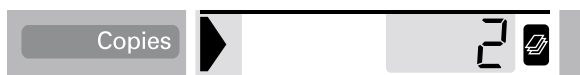

6. Select the print quality.

The example below shows printing at high quality.



7. Turn PhotoEnhance on or off.

The example below shows PhotoEnhance on.



8. Press the Print button.

Printing an Index Print

You can print one or more copies of an index of all the photographs on a loaded PC card. An index can be helpful in selecting which photos you want to print. The settings used in the instructions below are only examples. To find out what other settings are available, see “Display” on page 33.

Note:

Before printing, load paper and a PC card containing digital photo data in the printer. See “Loading Paper” on page 22 and “Loading PC Cards” on page 25 for details.

1. Select Index as the Print Mode setting.



2. Select the media type that is loaded in the sheet feeder.

The example below shows printing on plain paper.



3. Select the Paper Size that is loaded in the sheet feeder.

The example below shows printing on A4-size paper.



4. Select the number of copies to print.

The example shows printing only one sheet.



5. Select the Print Quality.

The example below shows printing at high speed.

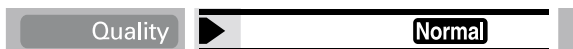

Note:

The Page Layout and PhotoEnhance settings are not available when printing an Index print.

6. Press the Print button.

All photographs on the PC card are printed out as an index.

Printing a Selected Photo

To print a selected photo, follow the instructions below. The settings used in the instructions are only examples. To find out what other settings are available, see “Display” on page 33.

1. Select One as the Print Mode setting.



2. Select the type and size of the media loaded in the sheet feeder. The example below shows A4-size EPSON Matte Paper-Heavyweight.

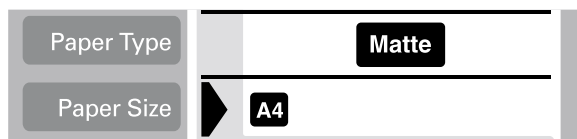

3. Select the Page Layout setting you want. The example below shows printing a photo twice on a single sheet of paper.



- Specify the number of the photo you want to print. The example below shows photo number 2.



Note:

Be sure to check the photo number with an index print or the optional Preview Monitor before you print.

- Specify the number of copies for the photo you selected in step 4.

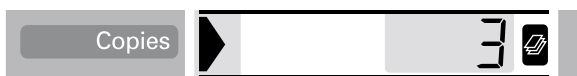

- Make the Quality and Photo Enhance settings. The example below shows printing at high quality with PhotoEnhance on.



- Press the Print button to print the specified photos.

Note:

To change the number of copies, move the cursor to the Copies setting, then select the number of copies with the left and right arrow buttons.

Printing Multiple Selected Photos

It is possible to specify the photo number and the number of copies for each photo before start printing. This function prints photos in the order that you specified on the display or with the optional Preview Monitor. The instructions below contain one example of the settings you can use. To find out about other available setting options, see “Display” on page 33.

1. Select Set as the Print Mode setting.



2. Select the type and size of the media loaded in the sheet feeder. The example below shows a 100 mm × 150 mm-size EPSON Photo Paper.

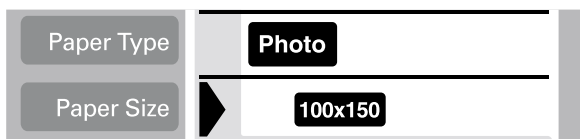

3. Select the layout that you want to print. The example below shows when printing four photos on a single sheet of paper.



- Specify the number of the photo you want to print. The example below shows photo number 2. Specify 0 as the number of photos to leave the print area blank.

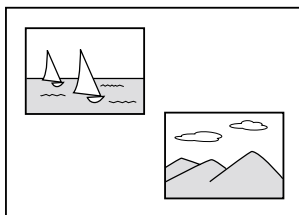

- Specify the number of copies for the photo you selected in step 4.



- Repeat steps 4 through 5 to select photos and specify the number of copies for each.
- Make the Quality and Photo Enhance settings. The example below shows printing at high quality with PhotoEnhance on.



- Press the Print button to print the selected photos.

Note:

To change the number of copies, move the cursor to the Copies setting, then select the number of copies with the left and right arrow buttons.

Printing with the DPOF setting

This printer conforms to DPOF (Digital Print Order Format) version 1.10. DPOF lets you set the photo numbers and the number of copies for photos on the digital camera before you print. To create DPOF data, you must use a digital camera that supports DPOF.

1. Load paper and a PC card which contains DPOF data. DPOF icon appears on the Select Photo menu as soon as you load the PC card into the printer's card slot. The printer is in DPOF mode.



To exit DPOF mode, move the cursor to the Select Photo menu. Then press the right or left arrow button. The DPOF icon disappears and the photo number appears.

2. Make the Paper Type, Paper Size, Page Layout, Quality, PhotoEnhance settings. The Copies menu shows the number of sheets of paper required for the selected layout.

Note:

Page Layout setting is not available when the DPOF settings are for an Index print.

3. Press the Print button to start printing.

For more details about DPOF settings, see your digital camera's documentation.

Expanded Layout Options

There are expanded layout options available for printing Stickers, Multi-sized photos, and Panoramic Layout Photos.

Printing stickers

You can print photographs directly from PC card on EPSON Photo Stickers 16.

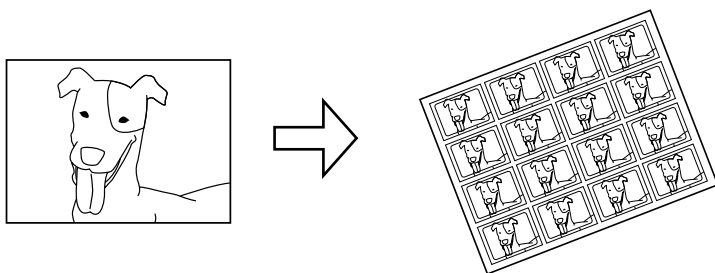

Original Photo

EPSON Photo Stickers 16

1. Load EPSON Photo Stickers 16 in the sheet feeder.
2. Insert a PC card which contains photo data.
3. Select the Print Mode; All, One or Set.
 - All: Print all photographs on a PC card one by one.
 - One: Print a selected photo on all stickers.
 - Set: Print multiple selected photos.

The example below shows the One mode.



4. Move the cursor to the Page Layout setting, then press the right or left arrow button for 3 seconds. All layout icons disappear.

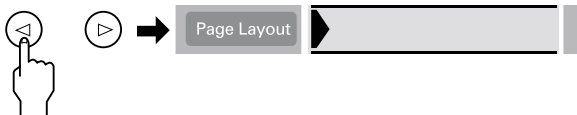

5. Select SE on the Copies menu with the left or right arrow button.

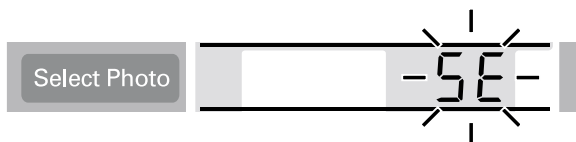

6. Specify the photo number and the number of copies that you want to print, when One or Set is selected for the Print Mode setting.

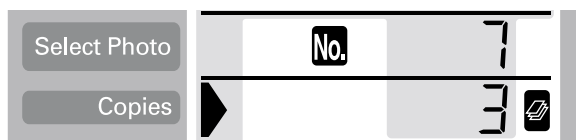

7. Make the Quality and Photo Enhance settings.

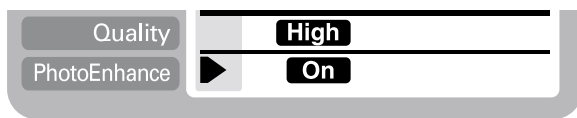

8. Press the Print button to print the stickers.

Printing Multi-sized photos

You can print several different photo sizes on a single sheet of paper.

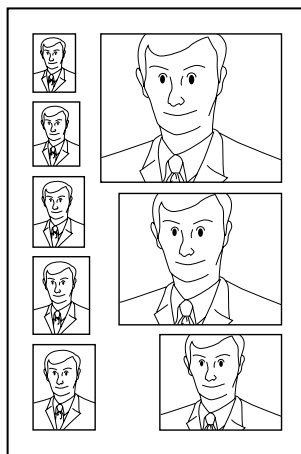

Original photo

Multi-sized photos

1. Select One for the Print Mode.



2. Select the paper type and size. Only A4 and 100 mm × 150 mm size sheet paper are available for this function.

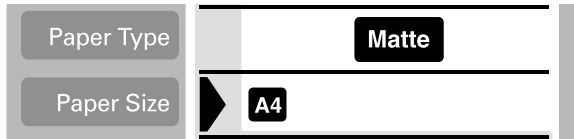

3. Move the cursor to the Page Layout setting, then press and hold the right or left arrow button for 3 seconds. All layout icons disappear.

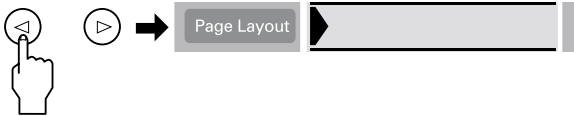

4. Select the ID with the right or left arrow buttons.

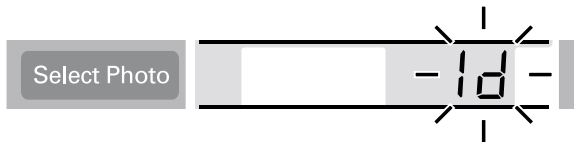

5. Specify the photo number and the number of copies that you want to print.

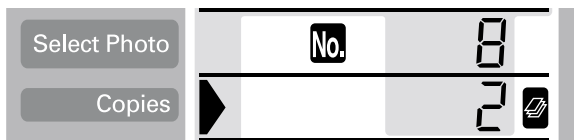

6. Make the Quality and Photo Enhance settings.



7. Press the Print button to print the Multi-sized photos.

Printing photos using the panoramic layout

You can print photos using a panoramic layout. This function adjusts the sides of photo image to the printable area. Note that data cannot be printed larger than the printable area.

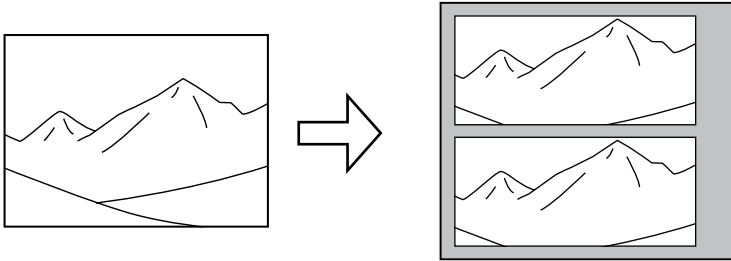

Original Photo

Panoramic Layout Photos

Note:

The purpose of this setting is to make a normal size photo look like a panoramic photo. Do not use this setting with photos taken with a digital camera in panoramic format.

1. Select the Print Mode; All, One or Set.

All: Print all photographs one by one in the panoramic layout.

One: Print a selected photo in the panoramic layout.

Set: Continuously print the selected photos in the panoramic layout.



2. Select the type and size of the media loaded in the printer.



3. Move the cursor to the Page Layout setting, then press and hold the left or right arrow button for 3 seconds. All layout icons disappear.

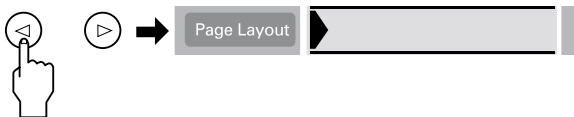

4. Select PA with the right or left arrow button.

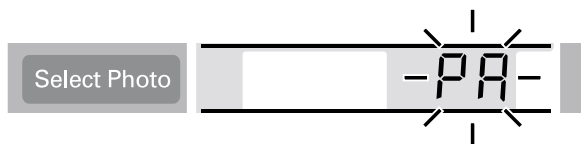

5. Specify the photo number and the number of copies that you want to print when One or Set is selected for the Print Mode setting.



6. Make the Quality and Photo Enhance settings.



7. Press the Print button to print in panoramic layout.

Using Filters

You can manually adjust the appearance of your photographs by using the filter function. There are 9 filter effects available. This function is not available when Index is selected for the Print Mode setting.

1. Make the Print Mode, Paper Type, Paper Size, Page Layout and Quality settings.

- Specify the photo number and the number of copies that you want to print, when One or Set is selected for the Print Mode setting.
- Press and hold the Brightness button for three seconds. The Filter icon flashes on the Copies menu.



- If you selected All or Set for the Print Mode setting, select the number of the photo on which you want to apply a filter.
- Select the number of the filter you want to use. The table below lists the filter numbers and their effects. Also refer to the color pages at the end of this guide for the examples of filter effects.

No.	Effect	No.	Effect
0	Off	5	Brighter
1	Monochrome	6	Slightly darker
2	Sepia	7	Darker
3	High contrast	8	Vivid
4	Slightly brighter	9	Sharp

Note:

If you select All or Set for the Print Mode setting and want to use a filter effect on all of the selected photographs, press and hold the Brightness button for 3 seconds. ALL appears on the Select Photo menu and the Filter icon stops flashing. The filter is applied to all photographs. To clear the filter setting, press the Cancel button.

- Press the Brightness button to select the filter effect. The Filter icon stops flashing.

7. When you select All or Set for the Print Mode setting, repeat the steps 3 to 5 to make filter settings for each photograph. To clear the each filter setting, select 0 (No effect) for the filter number. To clear all of filter settings, press the Cancel button.
8. Press Start to start printing.

To turn off filter effects, press the Cancel button.

Brightness Adjustment

You can adjust brightness of your printouts. This function effects all printed photographs. If you want to change the brightness levels for individual photographs, use the Filter function.

Note:

This setting is not available when Index is selected for the Print Mode setting.

1. Make the Print Mode, Paper Type, Paper Size, Page Layout and Quality settings.
2. Press the Brightness button. Brightness icon flashes on the Copies menu.



3. Select the brightness for the printouts.

The numbers correspond to the brightness effects as shown below.

Display	-2	-1	0	1	2
Brightness	Darker	Slightly darker	No effect	Slightly brighter	Brighter

4. Press the Brightness button to select the setting. The Brightness icon stops flashing.
5. Press the Start button to start printing.

Note:

The effect of the Brightness feature is the same as the filter effects of the same name. You cannot use both at the same time. If are the same as the 4. Slightly brighter, 5. Brighter, 6. Slightly darker, 7. Darker of the Filter effects, so you cannot use both of effects at the same time. In this case, always the filter effects prior to the brightness setting. However, it is possible to use the other combinations; for example, Dark Sepia, Slightly bright monochrome with using both filter and brightness setting.

Changing Default Settings

You can change the default settings to match settings you use frequently. You can make different default settings for each Print Mode, All, Index, One and Set. Any changes to the default settings are saved, even if you turn off the printer.

1. Make settings that you want to use as defaults. Photo numbers and the number of copies cannot be added.

2. Press the Select Photo and the Brightness button at the same time. The settings are saved as defaults.

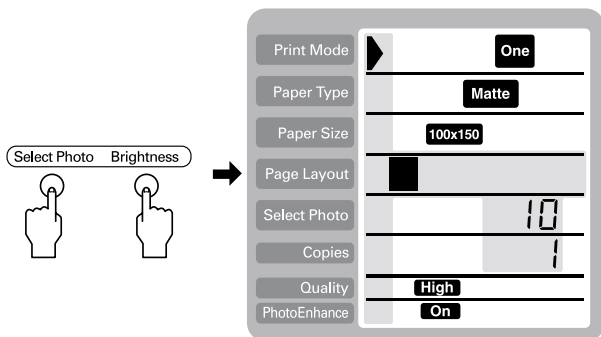

If you want to reset the default settings, specify the Print Mode that you want to reset, then press the Select Photo, Brightness and Cancel button at the same time. The Factory settings reappear and the preserved setting clears.





Replacing Ink Cartridges

Checking the Ink Supply

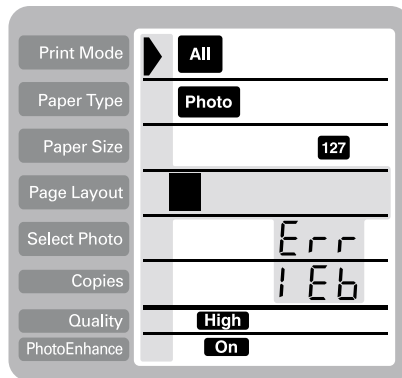
Using the LCD panel

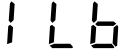
To check which cartridge requires replacing, check the LCD panel.



Error light	Display	Action
		Black ink cartridge is nearly empty.
		Color ink cartridge is nearly empty.
		Black ink cartridge is empty. Replace with a new one. Standard capacity, black: T007 Light capacity, black: T010
		Color ink cartridge is empty. Replace with a new one. Color: T008

● = on, ○ = off, ◌ = flashing

You can check the amount of ink remaining in the ink cartridges when running Nozzle Check from the printer's control panel. The Nozzle Check printout shows the percentage of remaining ink. To run the Nozzle Check from the printer's control panel, see "Using the control panel buttons" in the online *Reference Guide* for instructions.

Replacing an Ink Cartridge

This printer uses ink cartridges equipped with IC chips. The IC chip accurately monitors the amount of ink used by each cartridge, so even if a cartridge is removed and later inserted again, all of its ink can be used. However, some ink is consumed each time the cartridge is inserted because the printer automatically checks reliability.

**Warning:**

- ❑ *Keep ink cartridges out of the reach of children. Do not allow children to drink from or otherwise handle the cartridges.*

- ❑ *Be careful when you handle the used ink cartridges, as there may be some ink around the ink supply port. If ink gets on your skin, wash the area thoroughly with soap and water. If ink gets into your eyes, flush them immediately with water. If discomfort or vision problems remain after a thorough flushing, see a physician immediately.*

**Caution:**

- ❑ *EPSON recommends the use of genuine EPSON ink cartridges. Other products not manufactured by EPSON may cause damage to your printer not covered by EPSON's warranties.*

- ❑ *Leave the old cartridge installed in the printer until you have obtained a replacement, or ink remaining in the print head nozzles may dry out.*

- ❑ *Do not refill the ink cartridges. The printer calculates the amount of ink remaining using an IC chip on the ink cartridge. Even if the cartridge is refilled, the amount of ink remaining will not be recalculated by the IC chip and the amount of ink available for use will not change.*

Note:

- ❑ *You cannot continue printing with one ink cartridge empty, even if the other cartridge still contains ink. Before printing, replace the empty cartridge.*

- ❑ *In addition to the ink used during document printing, ink is consumed during the print head cleaning operation, during the self-cleaning cycle which is performed when the printer is turned on, and during ink charging when the ink cartridge is installed in the printer.*



- ❑ *If you replace the ink cartridges while the roll paper is loaded, the media may be smeared.*

For more information about ink cartridges, see “When handling the ink cartridges” on page 4.

1. Make sure that the printer is on, but not printing, then open the printer cover.

Note:

You can identify the status of the printer condition. If the error light is flashing, it means the black or color ink cartridge is low. If the error light is on and not flashing, it means the black or color ink cartridge is empty.

2. Press the  ink cartridge replacement button. The print head moves left to the Ink cartridge replacement position. The Processing light flashes, and the  error light comes on or flashes. To find out which cartridge requires replacing, see “Checking the Ink Supply” on page 57.



Caution:

Do not move the print head by hand, as this may damage the printer. Always press the  ink cartridge replacement button to move it.

3. Lift up the ink cartridge clamp as far as it will go. Take the cartridge out of the printer. If the cartridge is empty, dispose of it properly. Do not take the used cartridge apart or try to refill it.



Warning:

If ink gets on your hands, wash them thoroughly with soap and water. If ink gets into your eyes, flush them immediately with water. If discomfort or vision problems remain after a thorough flushing, see a physician immediately.

4. Remove the new ink cartridge from its protective bag and then only peel off the yellow tape seal. Do not touch the green IC chip on the side of the cartridge.

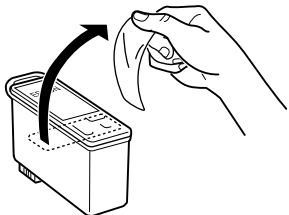

black ink cartridge (T007)

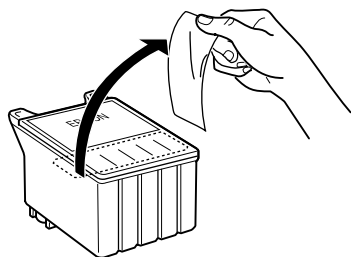

color ink cartridge (T008)



Caution:

- ❑ You must remove the yellow tape seal from the cartridge before installing it, or the cartridge will become unusable and you will be unable to print.

- ❑ If you have installed an ink cartridge without removing the yellow tape seal, you must remove the cartridge and install a new one. Prepare the new cartridge by removing the yellow tape seal, then install it in the printer.

- ❑ Do not remove the blue portion of the tape seal from the top of the cartridge, or the print head may become clogged and be unable to print.

- ❑ Do not remove the tape seal from the bottom of the cartridge or the ink will leak.

- ❑ Do not touch the green IC chip on the side of the cartridge, or normal operation and printing may not be possible.

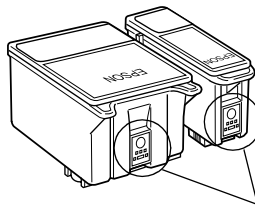

Do not touch this part.

- ❑ If an ink cartridge should be removed temporarily from the printer, be sure to protect the ink supply area of the ink cartridge from dirt and dust. Store the ink cartridge in the same environment as the printer. When storing the cartridge, be sure that it stands as shown in the illustration above (the label that identifies the color of the ink cartridge should be displayed on the top of the cartridge). The valve in the ink supply port is designed to contain any excess ink that may be released. However,

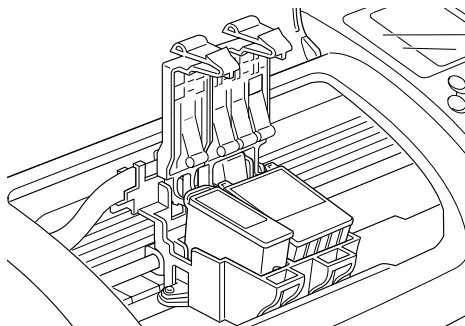

careful handling is recommended. Do not touch the supply port of the ink cartridge or its surrounding area.

5. Align the tabs on the ink cartridge so that they are resting on the tabs protruding from the base of the opened ink cartridge clamp. Push the clamps down until they lock firmly into place. Make sure that the ink cartridge tabs are not under the hinges protruding from the base of the opened ink cartridge clamp.



Caution:

After you remove an ink cartridge from the printer, please insert a new one immediately. If no cartridge is present, the print head may dry out and become unable to print.

6. Press the  ink cartridge replacement button. The print head will move and begins charging the ink delivery system. This process takes about one minute to complete. When the ink charging process is finished, the print head will return to its home position, the process light will stop flashing and remain on and the  error light will go out.



Caution:

The Processing light will continue to flash while the printer is charging ink. Never turn off the printer while this light is flashing. Doing so can result in incomplete charging of ink.



7. Close the printer cover.

Maintenance



Checking the Print Head Nozzles

If you find that the printed image is unexpectedly faint or dots in the printed image are missing, you may be able to identify the problem by checking the print head nozzles.

Follow the steps below to check the print head nozzles using the control panel buttons.

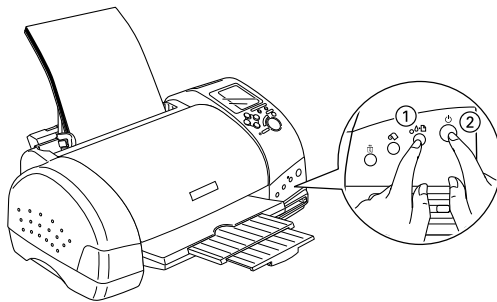
1. Turn off your printer.
2. Make sure that A4 or Letter size paper is loaded in the sheet feeder.
3. Hold down the  maintenance button (① in the illustration below) and press the  power button (② in the illustration below) to turn on the printer.



4. Release only the  power button. After the nozzle check starts, then release the  maintenance button.

The printer will print an operation check page that includes your printer's ROM version information, the ink counter code, ink levels, and a nozzle check pattern. To check the black remaining ink levels, see BK. For color ink levels, see CL. Below are sample printouts.

Good sample



Print head needs to be cleaned

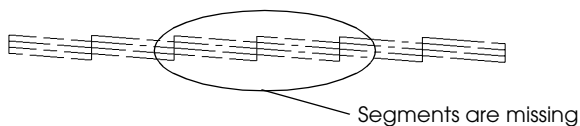

The above sample may be shown in black and white, but the actual test prints in color (CMYK).

If the nozzle check page does not print satisfactorily (for example, if any segment of the printed lines is missing), there is a problem with the printer. This could be a clogged ink nozzle or a misaligned print head. See the next section for details on cleaning the print head. For information on aligning the print head, see "Aligning the Print Head" in the online *Reference Guide*. The nozzle check page also indicates the amount of ink remaining in each cartridge. BK: shows the amount of remaining black ink, and CL: shows the amount of remaining color ink.

Cleaning the Print Head

If you find that the printed image is unexpectedly faint or dots in the printed image are missing, you may be able to solve these problems by cleaning the print head, which ensures that the nozzles are delivering ink properly.

Note:

- ❑ *Print head cleaning uses both color and black ink. To avoid wasting ink, clean the print head only if print quality declines (for example, if the printout is blurry or the color is incorrect or missing).*
- ❑ *Use the Nozzle Check utility first to confirm that the print head needs to be cleaned. This saves ink.*
- ❑ *When the Δ button error light is flashing or on, you cannot clean the print head. Replace the appropriate ink cartridge first.*
- ❑ *Do not start the Head Cleaning or Nozzle Check utility while printing is in progress, or your printout may be marred.*

Follow the steps below to clean the print head using the control panel buttons.

1. Make sure that the Processing light is on and that the Δ button error light is off.

Note:

If the Δ button error light is flashing or on, you cannot clean the head and this operation will start the ink cartridge replacement procedure. If you do not want to replace an ink cartridge at this moment, press the Δ button maintenance button to return the print head to its home position.

2. Hold down the Δ button maintenance button for three seconds.

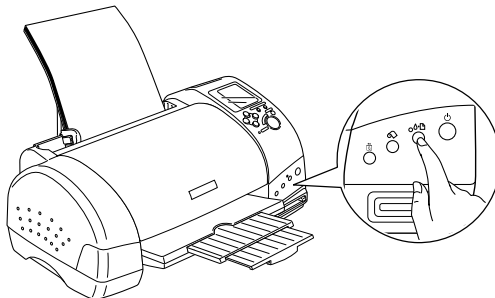

The printer will start cleaning the print head and the process light will begin flashing. Print head cleaning takes about thirty seconds to complete.



Caution:

Never turn off the printer while the Processing light is flashing. Doing so may damage the printer.

3. When the Processing light stops flashing, print a nozzle check pattern to confirm that the head is clean and to reset the cleaning cycle.

If print quality has not improved after repeating this procedure four or five times, turn the printer off and leave it alone overnight, then try head cleaning again.

If the print quality still has not improved, one or both of your ink cartridges may be old or damaged and may need to be replaced. To replace an ink cartridge before it is empty, see “Replacing an Ink Cartridge” on page 58.

If print quality remains a problem after replacing the ink cartridges, contact your dealer.

Note:

To maintain print quality, we recommend turning on the printer for at least one minute every month.

Cleaning the Printer

To keep your printer operating at its best, clean it thoroughly several times a year as follows.

1. Unplug the printer’s power cord.
2. Remove any paper from the sheet feeder.

3. Use a soft brush to carefully clean away all dust and dirt from the sheet feeder.
4. If the outer case or the inside of the sheet feeder is dirty, wipe it with a soft, clean cloth dampened with mild detergent. Keep the printer cover closed to prevent water from getting inside.
5. If the inside of the printer accidentally gets soiled with ink, wipe it off with a damp cloth.



Warning:

Be careful not to touch the gears or rollers inside the printer.



Caution:

Be careful not to wipe grease on the metal parts under the ink carriage passage.

Never use alcohol or thinner to clean the printer, as these chemicals can damage the components as well as the case.

Be careful not to get water on the printer mechanism or electronic components.

Do not use a hard or abrasive brush.

Do not spray the inside of the printer with lubricants. Unsuitable oils can damage the mechanism. Contact your dealer or a qualified service person if lubrication is needed.

Only use a dry, soft cloth to clean the display and the optional Preview Monitor. Do not use liquid or chemical cleansers.

Transporting the Printer

If you need to transport your printer, carefully prepare and repack it as described below using the original box (or a similar box that the printer fits snugly into) and packing materials. Follow the steps below.

1. Open the printer cover and make sure that the print head is in the home (far right) position. If not, plug in the printer, wait until the print head returns to the home position, then close the printer cover and unplug the printer.



Caution:

Leave the ink cartridges installed when you transport the printer. Transporting the printer without cartridges in place can damage the printer.

2. Disconnect the interface cable from the printer.
3. Remove the paper from the sheet feeder and remove the paper support.
4. Open the printer cover again. Secure the ink cartridge holder to the printer with the protective material and tape as shown below, then close the printer cover.

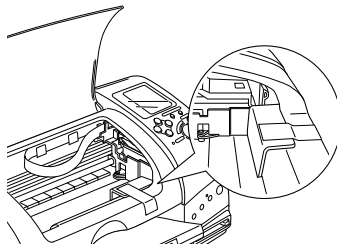

5. Raise the output tray.
6. Attach the protective materials to both sides of the printer.

7. Repack the printer and power cord in the original box.
8. Keep the printer level during transport.

Troubleshooting

Error Indicators and Display



You can identify many common printer problems using the lights or display on your printer's control panel. If the lights are on or flashing, use the following table of panel light patterns to diagnose the problem, then implement the recommended corrective measures.

Lights		Problem and Solution	
●	△□	Paper out	
		No paper is loaded in the printer.	Load paper in the sheet feeder, then press the △□ maintenance button. The printer will resume printing and the light will go out.
●	△□	Paper jam	
		Paper has jammed in the printer.	Press the △□ maintenance button to eject the jammed paper. If the error does not clear, open the printer cover and remove all of the paper inside, including any torn pieces. Reload the paper in the sheet feeder and press the △□ maintenance button to resume printing.
○	△□	Ink low	
		The black or color ink cartridge is nearly empty.	Obtain a replacement black or color ink cartridge. Black: T007 (Standard Capacity) T010 (Light Capacity) Color: T008

●	△□	Ink out	
		The black or color ink cartridge is empty or not installed.	Replace the black or color ink cartridge with a new one. See "Replacing an Ink Cartridge" on page 58 for details. Black: T007 (Standard Capacity) T010 (Light Capacity) Color: T008
		Wrong cartridge	
		The installed black or color ink cartridge cannot be used by this printer.	Use the appropriate black or color ink cartridge. See "Replacing an Ink Cartridge" on page 58 for details. Black: T007 (Standard Capacity) T010 (Light Capacity) Color: T008
○	Processing	Carriage error	
●	△□	The print head carriage is obstructed by jammed paper or other foreign material and cannot return to the home position.	Turn off the printer. Open the printer cover and remove any paper from the paper path by hand, then, turn the printer back on. If the error does not clear, contact your dealer.
◌	Processing	Unknown printer error	
◌	△□	An unknown printer error has occurred.	Turn off the printer and contact your dealer.

● = on, ○ = off, ◌ = flashing

Display	Problem	Solution
1 Lb	The black ink cartridge is nearly empty.	Obtain a replacement black ink cartridge.
1 Lc	The color ink cartridge is nearly empty.	Obtain a replacement color ink cartridge.
Err 1 Eb	The black ink cartridge is empty.	Replace the black ink cartridge with a new one.
Err 1 Ec	The color ink cartridge is empty.	Replace the color ink cartridge with a new one.
Err PE	No paper is loaded in the printer.	Load paper in the sheet feeder; then press the ⏏ maintenance button to turn this light off. The printer resumes printing.
Err PJ	Paper has jammed in the printer.	Take all the paper out of the feeder, and reload the paper; then press the ⏏ maintenance button to turn this light off. If the light continues to flash, turn off the printer and gently pull all the paper out of the printer. If it tears and pieces remain inside the printer, open the printer cover and remove the pieces of paper. Turn on the printer and try again.
Err 1 C	The black or/and color ink cartridge is not installed properly.	Reinstall cartridge.

	<p>Internal printer parts need adjustment or replacement.</p>	<p>Turn the printer off, and after a few seconds, turn it on again. If the error is not cleared, contact your dealer.</p>
	<p>The storage media or PC card is not compatible with this printer.</p>	<p>Use a compatible storage media or PC card. See "Loadable storage media" on page 25.</p>
	<p>An unknown printer error has occurred.</p>	<p>Turn the printer off, and after a few seconds, turn it on again. If the error is not cleared, contact your dealer.</p>

Print Quality Problems

Horizontal banding

Try one or more of these solutions:

- Make sure that the printable side of the paper is face up in the sheet feeder.
- Run the Head Cleaning utility to clear any clogged ink nozzles. See "Cleaning the Print Head" on page 65.
- Make sure that the Media Type selected in the Control Panel is appropriate for the type of media loaded in the printer.
- Make sure that the position of the adjust lever is appropriate for the media type. When printing on media of normal thickness, set the adjust lever to the "0" position. When printing on envelopes or thick media, set the position to "+".

Vertical misalignment or banding

Try one or more of these solutions:

- Make sure that the printable side of the paper is face up in the sheet feeder.
- Run the Head Cleaning utility to clear any clogged ink nozzles. See “Cleaning the Print Head” on page 65.
- Make sure that the Media Type setting selected in the Control Panel is appropriate for the type of media loaded in the printer.
- Make sure that the position of the adjust lever is appropriate for the media type. When printing on media of normal thickness, set the adjust lever to the “0” position. When printing on envelopes or thick media, set the position to “+”.

Color gaps

Try one or more of these solutions:

- Make sure that your paper is not damaged, dirty, or too old. Also, make sure that the printable side of the paper is face up in the sheet feeder.
- Run the Head Cleaning utility to clear any clogged ink nozzles. See “Cleaning the Print Head” on page 65.
- Check the  error light. If the light is flashing, replace the appropriate ink cartridge. See “Replacing an Ink Cartridge” on page 58.
- Make sure that the Media Type setting selected in the Control Panel is appropriate for the type of media that is loaded in the printer.

Incorrect or missing colors

Try one or more of these solutions:

- ❑ Run the Head Cleaning utility. See “Cleaning the Print Head” on page 65. If colors are still incorrect or missing, replace the color ink cartridge. If the problem persists, replace the black ink cartridge. See “Replacing an Ink Cartridge” on page 58 for details.
- ❑ Make sure that you are not using an ink cartridge with an expired date printed on the cartridge carton. Also, if you have not used the printer for a long time, replace with new ink cartridges. See “Replacing an Ink Cartridge” on page 58.

Blurry or smeared printout

Try one or more of these solutions:

- ❑ Make sure that the printer is on a flat, stable surface that extends beyond the printer base in all directions. The printer will not operate properly if it is tilted.
- ❑ Make sure that your paper is dry and that the printable side is facing up. Also, make sure that you are using an acceptable paper type. See “Paper” on page 95 for specifications.
- ❑ If the paper is curled toward the printable side, flatten it or curl it slightly in the opposite direction.
- ❑ Set the adjust lever to the “+” position, and make sure the Media Type setting in the Control Panel is correct.
- ❑ Remove each sheet from the output tray as it is printed, especially if you are using transparencies.

- ❑ If you are printing on glossy media, place a support sheet (or a sheet of plain paper) beneath the stack, or load only one sheet at a time.
- ❑ When printing on thick media, set the adjust lever to the “+” position.
- ❑ Run the Head Cleaning utility. See “Cleaning the Print Head” on page 65.
- ❑ Load and eject dry paper several times. If the problem persists, ink may have leaked inside the printer, so wipe the inside of the printer with a soft, clean cloth.

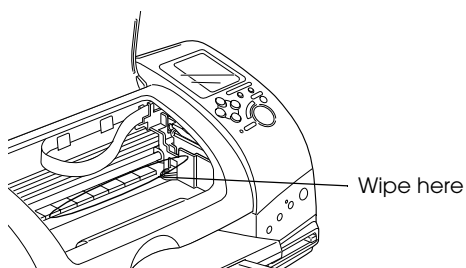

Warning:

Be careful not to touch the gears or rollers inside the printer.



Caution:

Be careful not to wipe grease on the metal parts under the print head path.

Printout Problems Not Related to Print Quality

If one of the following problems has occurred, try the solutions listed for the problem.

- ❑ Blank pages print

- Printout has smears on the bottom edge
- Printing is too slow

Blank pages print

- Run the Head Cleaning utility to clear any clogged nozzles. See “Cleaning the Print Head” on page 65.

Printout has smears on the bottom edge

- If the paper is curled toward the printable side, flatten it or curl it slightly in the opposite direction.
- Set the adjust lever to the “+” position.

Printing is too slow

- Make sure that the Media Type setting in the Control Panel is correct.

Paper Does Not Feed Correctly

If one of the following problems has occurred, try the solution(s) listed for that problem.

- Paper does not feed
- Multiple pages feed
- The paper jams
- Paper is not ejected fully or is wrinkled

Paper does not feed

Remove the stack of paper and make sure of the following:

- The paper is not curled or creased.
- The paper is not too old. See the instructions that came with the paper for more information.
- The paper is not loaded higher than the arrow on the left edge guide.
- Paper is not jammed inside the printer. If it is, remove the jammed paper.
- The black and/or color ink cartridges are not empty. If one is, replace the appropriate cartridge. To determine which cartridge is empty, see “Replacing an Ink Cartridge” on page 58.



Load the paper again. Make sure that you follow any special loading instructions that came with your paper. Also see “Available Media Types” on page 19.

Multiple pages feed

- For the users directly printing from PC card, do not select A4 or 100 × 150 mm sheet paper for the Paper Size setting when roll paper is loaded in the sheet feeder. Doing so causes unnecessary paper to be fed after each print job. If you have already started printing, press the **CANCEL** button. Wait until the printer stops printing and feeding paper. Cut off the paper at the back of the printer, then turn off the printer. The remaining paper is ejected.
- Make sure that the paper stack fits under the arrow mark located on the inside surface on the left edge guide.

- ❑ Make sure that the left edge guide is snug to the left edge of the paper.
- ❑ Make sure that the paper is not curled or folded. If so, flatten it or curl it slightly toward the opposite side before loading.
- ❑ Make sure that the position of the adjust lever is appropriate for the media type. When printing on media of normal thickness, set the adjust lever to the “0” position. When printing on envelopes and thick media, set the position to “+”.
- ❑ Remove the stack of paper and make sure that the paper is not too thin. See “Paper” on page 95 for specifications. Fan the edges of the stack to separate the sheets, then reload the paper.

Paper jams

Press the  maintenance button to eject the jammed paper. If the error does not clear, open the printer cover and remove all of the paper inside, including any torn pieces, then reload the paper in the sheet feeder and press  maintenance button to resume printing.

Note:

If you cannot remove a foreign object easily by yourself, do not use force and do not disassemble the printer. Call your dealer for assistance.

If your paper jams frequently, make sure of the following:

- ❑ The paper is smooth, not curled or wrinkled.
- ❑ The printable side of the paper is face up in the sheet feeder.
- ❑ The paper stack was fanned before loading.
- ❑ The paper is not loaded above the arrow on the left edge guide.

- ❑ The left edge guide is adjusted to fit your paper.
- ❑ The printer is on a flat, stable surface that extends beyond the printer base in all directions. The printer will not operate properly if it is tilted.

Paper improperly loaded

If you have loaded the paper too far into the printer, the printer cannot feed the paper correctly. Turn the printer off and gently remove the paper. Then turn the printer on and reload the paper properly.

Paper is not ejected fully or is wrinkled

Try one or more of these solutions:

- ❑ If the paper does not eject fully, press the ⏏ maintenance button, then open the printer cover and remove the paper. Also, check the Paper Size setting in the Control Panel.
- ❑ If the paper is wrinkled when it comes out, it may be damp or too thin. Load a new stack.

Note:

Store any unused paper in its original packaging in a dry area. See "Paper" on page 95 for specifications

Printer Does Not Print

If the printer does not print, check and see if one of the following error indications is displayed, then try the solutions listed.

- ❑ All lights are off

- Lights came on and then went out
- Only the process light is on
- The Δ -E error light is flashing or on
- One of the ink out lights is flashing or on
- Ink out lights are on and the other lights are flashing

All lights are off

Try one or more of these solutions:

- Press the  power button to make sure that the printer is on.
- Turn off the printer and make sure that the power cord is securely plugged in.
- Make sure that your outlet works and is not controlled by a wall switch or timer.

Lights came on and then went out

The printer's voltage may not match the outlet rating. Turn off the printer and unplug it immediately, then check the printer labels.

If the voltage does not match, DO NOT PLUG YOUR PRINTER BACK IN. Contact your dealer.

Only the Processing light is on

Try one or more of these solutions:





- Make sure that there is no packing material in the printer.

- ❑ If the printer sounds like it is trying to print, but is unable to, run the Head Cleaning utility. See “Cleaning the Print Head” on page 65.

If this does not work, replace the ink cartridges. See “Replacing an Ink Cartridge” on page 58 for instructions.

Error light is flashing or on

Try one or more of these solutions:

- ❑ If the  error light is on and paper is jammed in the printer, remove the paper from the printer.
- ❑ If the  error light is on and no paper is loaded, load more paper in the sheet feeder.
- ❑ If the  error light is flashing, ink is low. Obtain a replacement cartridge of the appropriate type. To determine which cartridge is low, see “Replacing an Ink Cartridge” on page 58.
- ❑ If the  error light is on and ink is out, replace the appropriate ink cartridge. To determine which ink cartridge is empty, see “Replacing an Ink Cartridge” on page 58.

Error light is on and the Processing light is flashing

Follow the steps below.

1. Press the  maintenance button, then remove any paper in the printer.

2. Turn the printer off. Check for and remove any foreign objects or pieces of paper from inside the printer. Also, make sure that there is sufficient space around the vent on the back of the printer to allow proper ventilation. Remove any objects blocking the vent, then turn the printer back on.

Note:

If you cannot remove a foreign object easily by yourself, do not use force and do not disassemble the printer. Call your dealer for assistance.

3. If the error does not clear, contact your dealer.

Cancelling Printing

If you encounter problems while printing, you may need to cancel printing. To stop printing in progress, press **CANCEL** button. The printer will cancel all print jobs and stop printing, and eject any pages which is printing. Depending on the printer's status, printing may not stop immediately.

Exif Print

Exif2.2, a new standard for digital cameras, also called “Exif Print.”, has been established to make the use of fine digital photos easier.

Printing with PRINT Image Matching

How is PRINT Image Matching used?

This product supports PRINT Image Matching and PRINT Image Matching II. When used in combination, PRINT Image Matching or PRINT Image Matching II enabled digital still cameras, printers and software help photographers to produce images more faithful to their intentions.

The PRINT Image Matching function can be utilized if this EPSON printer is used to print images from input devices, such as digital cameras, loaded with the PRINT Image Matching function. Print commands are attached to image data for printing if photos are taken with an input device loaded with the PRINT Image Matching function.

Note:

- ❑ *See the relevant input device instruction manual for details concerning the use of devices loaded with the PRINT Image Matching function.*
- ❑ *Please check with the input device manufacturer to determine whether it is loaded with the PRINT Image Matching function.*

Printing without a PC

Insert the digital camera memory card into the memory card slot, specify the image to be printed to retrieve print commands registered in the image file and print.

Media for which PRINT Image Matching is enabled

PRINT Image Matching is enabled when the following media are used:

Plain Paper/EPSON Premium Ink Jet Plain Paper/
EPSON Bright White Ink Jet Paper/EPSON Photo Paper/
EPSON Matte Paper-Heavyweight/
EPSON Premium Glossy Photo Paper/
EPSON ColorLife Photo Paper

Customer Support

Technical Support Web Site

EPSON's Technical Support Web Site provides help with problems that cannot be solved using the troubleshooting information in your printer documentation. If you have a Web browser and can connect to the Internet, access that site at:

<http://support.epson.net/StylusPhoto915/>

Contacting Customer Support

If your EPSON product is not operating properly and you cannot solve the problem using the troubleshooting information in your product documentation, contact customer support services for assistance. If customer support for your area is not listed below, contact the dealer where you purchased your product.

Customer support will be able to help you much more quickly if you give them the following information:

- Product serial number
(The serial number label is usually on the back of the product.)
- Product model
- Product software version
(Click About, Version Info, or similar button in the product software.)
- Brand and model of your computer
- Your computer operating system name and version

- ❑ Names and versions of the software applications you normally use with your product

United Kingdom

www.epson.co.uk

Stylus Products Warranty & Support: 08705 133 640

Scanner Products Warranty & Support: 08702 413 453

Sales: 0800 220 546

Republic of Ireland

www.epson.co.uk

Stylus Products Warranty & Support: 01 679 9016

Other Products Warranty & Support: 01 679 9015

Sales: 1 800 409 132

Denmark

www.epson.dk

Warranty & Support: 80 88 11 27

Sales: 38 48 71 37

Finland

www.epson.fi

Warranty & Support: 0800 523 010

Sales: (09) 8171 0083

Norway

www.epson.no

Warranty & Support: 800 11 828

Sales: 23 16 21 24

Sweden

www.epson.se

Warranty & Support: 08 445 12 58

Sales: 08 519 92 082

Israel

www.epson.com

Warranty & Support: 04 8 560 380

Middle East

www.epson.com

Warranty & Support: + 971 (0) 4 352 44 88 or 351 77 77

Support Email: www.epson-support@compubase.co.ae

South Africa

www.epson.co.za/

For details of EPSON Express centres and Service Repair centres:
<http://www.epson.co.za/support/index.htm>

Warranty & Support: (011) 444 8278 / 91 or 0800 600 578

Sales: (011) 262 9200 or 0800 00 5956

Options and Consumable Products

Options

The following options are available for your printer.

Interface cables

EPSON supplies the following interface cable for your printer. However, you can use any interface cables that meet these specifications. See your computer manual for any additional requirements.

USB Interface Cable (shielded) C83623* from Series A 4-pin (computer) to series B 4-pin (printer).

Note:

- ❑ *The asterisk (*) is a substitute for the last digit of the product number, which varies by location.*
- ❑ *Depending on your geographic location, this cable may not be supplied.*



Caution:

Use only interface cables which meet the specifications listed above. Using other cables not covered by EPSON warranties may cause the printer to malfunction.

Preview Monitor

When printing directly from PC card, the Preview Monitor C86000* lets you easily find photos on the memory card. Use the left and right arrow buttons on the Select Photo menu to select the photos that you want to print on the memory card. This monitor only displays the Page Layout and Select Photo settings.



Caution:

Be sure to turn off your printer and unplug the printer's power cord before attaching or removing the preview monitor. Failure to do so can damage the preview monitor.

Note:

- ❑ *The asterisk (*) is a substitute for the last digit of the product number, which varies by location.*
- ❑ *To adjust the tilt of the Preview Monitor, loosen the knob on the right side of the Preview Monitor.*

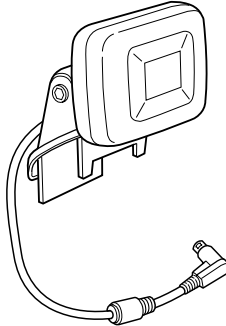

Consumable products

The following ink cartridges and EPSON special media are available for your printer.

Ink cartridges

You can use the following cartridges with your printer:

Type of ink	Product numbers of ink
Black ink cartridge	Standard Capacity: T007 Light Capacity: T010
Color ink cartridge	T008

Note:

The product numbers of ink cartridges may vary by location.

Media types

EPSON offers specially-designed media for ink jet printers to meet most high-quality printing needs.

Plain Paper

Plain paper

EPSON Premium Ink Jet Plain Paper (A4) S041214

EPSON Bright White Ink Jet Paper (A4) S041442

Photo Paper

EPSON Photo Paper (A4)	S041140
EPSON Photo Paper (100 × 150 mm)	S041255
EPSON Photo Paper (100 mm × 8 m)	S041279
EPSON Photo Paper (210 mm × 10 m)	S041280

Matte Paper-Heavyweight

EPSON Matte Paper-Heavyweight (A4)	S041256
	S041258
	S041259

Premium Glossy Photo Paper

EPSON Premium Glossy Photo Paper (A4)	S041287
	S041297
	S041285
EPSON Premium Glossy Photo Paper (100 mm × 8 m)	S041302
	S041303
EPSON Premium Glossy Photo Paper (127 mm × 8 m)	S041474
EPSON Premium Glossy Photo Paper (210 mm × 10 m)	S041376
	S041377

Photo Stickers

EPSON Photo Stickers 16 (A6)	S041144
------------------------------	---------

Printer Specifications

Printing

Printing method	On-demand ink jet
Nozzle configuration	Monochrome (black) 48 nozzles Color (cyan, magenta, yellow, light cyan, light magenta) 240 nozzles (48 × 5 colors)
Resolution	Maximum 2880 dpi × 720 dpi
Print direction	Bidirectional with logic seeking
Control code	ESC/P Raster EPSON Remote
Input buffer	32 KB

Paper

Note:

Since the quality of any particular brand or type of paper may be changed by the manufacturer at any time, EPSON cannot attest to the quality of any non-EPSON brand or type of paper. Always test samples of paper stock before purchasing large quantities or printing large jobs.

Paper specifications

Single sheets:

Size A4 (210 mm × 297 mm)

Paper types Plain bond paper, special paper distributed by EPSON

Thickness 0.08 mm to 0.11 mm (0.003 to 0.004 inch)
(for plain bond paper)

Weight 64 g/m² (17 lb) to 90 g/m² (24 lb)
(for plain bond paper)

Matte Paper-Heavyweight:

Size A4 (210 mm × 297 mm)

Paper types Special paper distributed by EPSON

Photo Paper:

Size A4 (210 mm × 297 mm)

100 mm × 150 mm

100 mm × 8 m

210 mm × 10 m

Paper types Special paper distributed by EPSON

Premium Glossy Photo Paper:

Size A4 (210 mm × 297 mm)
 100 mm × 8 m
 127 mm × 8 m
 210 mm × 10 m

Paper types Special paper distributed by EPSON

Photo Stickers:

Size A6 (105 mm × 148 mm) with 16 frames

Paper types Special paper distributed by EPSON

Note:

- ❑ *Poor quality paper may reduce print quality and cause paper jams or other problems. If you encounter problems, switch to a higher grade of paper.*
- ❑ *Do not load curled or folded paper.*
- ❑ *Use paper under normal conditions:
Temperature 15 to 25° C (59 to 77° F)
Humidity 40 to 60% RH*

Printable area

Single sheets

Normal

No Margins**

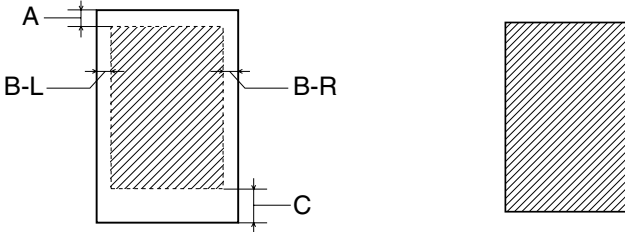

Diagonal lines show printable area.

A: The minimum top margin is 3.0 mm (0.12").

B-L: The minimum left margin is 3.0 mm (0.12").

B-R: The minimum right margin is as follows:
3.0 mm (0.12") for single sheets.

C: The minimum bottom margin is 14.0 mm (0.55").

**:

When printing with the No Margins feature, print quality may decline in the top and bottom areas of the printout, or the area may be smeared.

Note:

Always load paper into the sheet feeder short edge first. Load envelopes flap edge first with the flap side down.

Ink Cartridges

Black ink cartridge (T007, T010)

There are two types of black ink cartridges. The Light Capacity ink cartridge (T010) contains half as much ink as the standard capacity ink cartridge (T007).

Color	Black
Print capacity*	Standard Capacity (T007): 540 pages (A4, text at 360 dpi) Light Capacity (T010): 270 pages (A4, text at 360 dpi)
Cartridge life	2 years from production date (within 6 months after opening package, at 25°C (77°F))
Temperature	Storage: -20 to 40°C (-4 to 104°F) 1 month at 40°C (104°F) Transit: -30 to 60°C (-22 to 140°F) 1 month at 40°C (104°F) 120 hours at 60°C (140°F) Freezing:** -16°C (3.2°F)
Dimensions	20.1 mm (W) × 60.0 mm (D) × 38.5 mm (H)

Color ink cartridge (T008)

Color	Cyan, Magenta, Yellow, Light cyan and Light magenta
Print capacity*	220 pages (A4, 360 dpi, 5% duty each color)
Cartridge life	2 years from production date (within 6 months of opening the package at 25°C (77°F))
Temperature	Storage: -20 to 40°C (-4 to 104°F) 1 month at 40°C (104°F) Transit: -30 to 60°C (-22 to 140°F) 1 month at 40°C (104°F) 120 hours at 60°C (140°F) Freezing:** -18°C (-0.4°F)
Dimensions	49.1 mm (W) × 60.0 mm (D) × 38.5 mm (H)

* The figure given is based upon continuous printing after ink replacement. The actual print capacity may vary, depending on how often you use the print head cleaning function and how often you turn the printer on.

** Ink thaws and is usable after approximately 3 hours at 25°C (77°F).



Caution:

- ❑ *EPSON recommends the use of original EPSON ink cartridges only. Products not manufactured by EPSON may cause damage to your printer not covered by EPSON's warranties.*

- ❑ *Do not use an ink cartridge if the date on the package has expired.*

- ❑ *Do not refill the ink cartridge. The printer calculates the amount of ink remaining using an IC chip on the ink cartridge, so even if the cartridge is refilled, the IC chip will report that it is empty.*

Mechanical

Paper feed method	Friction
Paper path	Sheet feeder, rear entry
Sheet feeder capacity	About 100 sheets at 64 g/m ² (17 lb) paper
Dimensions	Storage Width: 467 mm (18.4 inches) Depth: 255.7 mm (10.1 inches) Height: 212.1 mm (8.4 inches)
	Printing Width: 467 mm (18.4 inches) Depth: 547 mm (21.5 inches) Height: 302 mm (11.9 inches)
Weight	5.25 kg (11.6 lb) without the ink cartridges

Electrical

	120 V Model	220-240 V Model
Input voltage range	99 to 132 V	198 to 264 V
Rated frequency range	50 to 60 Hz	
Input frequency range	49.5 to 60.5 Hz	
Rated current	0.45 A	0.25 A
Power consumption	Approx. 19 W (ISO10561 Letter Pattern) Approx. 3.5 W in standby mode	

Note:

Check the label on the back of the printer for the voltage of your printer.

Operating Environment

Temperature	Operation: 10 to 35°C (50 to 95°F) Storage: -20 to 40°C (-4 to 104°F) 1 month at 40°C (104°F) Transit:* -20 to 60°C (-4 to 140°F) 120 hours at 60°C (140°F)
Humidity	Operation: 20 to 80% RH Storage:*,** 5 to 85% RH

* Stored in a shipping container

** Without condensation

Standards and Approvals

U.S. model:

Safety

UL 1950
CSA C22.2 No.950

EMC

FCC Part 15 Subpart B Class B
CSA C108.8 Class B

European model:

Low Voltage Directive
73/23/EEC

EN 60950

EMC Directive
89/336/EEC

EN 55022 Class B

EN 55024

EN 61000-3-2

EN 61000-3-3

Australian model:

EMC

AS/NZS 3548 Class B

EPSON OVERSEAS MARKETING LOCATIONS

EPSON AMERICA, INC.

3840 Kilroy Airport Way
Long Beach, CA 90806
Phone: (562) 981-3840
Fax: (562) 290-5220

EPSON UK LTD.

Campus 100, Maylands Avenue,
Hemel Hempstead, Herts,
HP2 7TJ, U.K.
Phone: (+44) 01442 261144
Fax: (+44) 01442 227227

EPSON DEUTSCHLAND GmbH

Zülpicher Straße 6,
40549 Düsseldorf Germany
Phone: (0211) 56030
Fax: (0211) 5047787

EPSON FRANCE S.A.

68 bis, rue Marjolin
92300, Levallois-Perret, France
Phone: 33.1.41.86.26.56
Telex: 610657

EPSON AUSTRALIA PTY. LTD.

70 GIBBES STREET,
CHATSWOOD 2067 NSW.
Phone: 2-9903-9000
Fax: 2-9903-9177

EPSON SINGAPORE PTE. LTD.

No. 1 Temasek Avenue #36-00
Millenia Tower, Singapore 039192
Phone: (065) 633 77 911
Fax: (065) 633 41 185

EPSON HONG KONG LTD.

Rooms 4706-10, 47/F,
China Resources Bldg.,
26 Harbour Road, Wanchai, Hong Kong
Phone: 2585-4300
Fax: 2827-7083

EPSON TAIWAN TECHNOLOGY & TRADING LTD.

10F, No. 287 Nanking E. Road, Sec. 3,
Taipei, Taiwan,
Phone: (02) 2717-7360
Fax: (02) 2712-9164

EPSON ITALIA S.p.A.

V.le F.lli Casiraghi 427
20099 Sesto S.Giovanni
MI, Italy
Phone: +3902262331
Fax: +39022440750

EPSON IBERICA S.A.

Av. de Roma, 18-26
08290 Cerdanyola del Valles
Barcelona, Spain
Phone: 582. 15.00
Fax: 582. 15.55

**SEIKO EPSON CORPORATION
(Hirooka Office)**

80 Harashinden, Hirooka
Shiojiri-shi, Nagano-ken
399-0785 Japan

EPSON PORTUGAL, S.A.

R. do Progresso, 471, 1° Perafita
4460 Matosinhos, Portugal
Phone: (02) 996 14 02
Fax: (02) 996 14 11

EPSON

Color Ink Jet Printer



EPSON STYLUS™ PHOTO 915

Daily Use

Printed in Japan
02.XX-XX