

PF-124

Service Manual



CONTENTS

GENERAL

- 1. SpecificationsG-1
- 2. Revolving Parts Layout DrawingG-1
- 3. Electric Parts Layout DrawingG-2

DIS/REASSEMBLY, ADJUSTMENT

- 1. Maintenance ScheduleD-1
- 2. Disassembly and CleaningD-2
 - 2-1. Removal of the Outer CoverD-2
 - 2-2. Removal of the Pickup Roller/Take-Up Roller/Separator Roll AssyD-3
 - 2-3. Cleaning of the Pickup Roller/Paper Take-Up Roller/Separator RollD-5
 - 2-4. Cleaning of the Vertical Transport RollerD-6
- 3. AdjustmentD-7
 - 3-1. Registration CDD-7
 - 3-2. Registration FDD-10

TROUBLESHOOTING

- 1. IntroductionT-1
 - 1-1. Electrical Components Check ProcedureT-1
 - (1) SensorT-1
 - (2) SwitchT-2
 - (3) SolenoidT-2
 - (4) ClutchT-3
 - (5) MotorT-3
- 2. I/O CHECKT-5
 - 2-1. I/O Check ListT-6
- 3. Misfeed Detection/Troubleshooting ProceduresT-7
 - 3-1. Initial ChecksT-7
 - 3-2. Misfeed-Detecting Sensor LayoutT-8
 - 3-3. Misfeed DetectedT-9
 - 3-4. Misfeed Detection Timing/Troubleshooting ProceduresT-10
 - (1) Paper Take-Up MisfeedT-10
- 4. Malfunction Detection/Troubleshooting ProcedureT-11
 - 4-1. Malfunction DetectionT-11
 - (1) C0900: 3rd Drawer Lift-Up Motor FailureT-12

GENERAL



1. Specifications

Name	: 2 way Paper Take-Up Cabinet
Type	: Front loading type 2 way paper take-up device
Installation	: Desk type
Paper Type	: Plain paper 15lb. to 29.4lb. (56 g/m ² to 110 g/m ²), recycled paper 16lb. to 24lb. (60 g/m ² to 90 g/m ²)
Paper Size	: A5L to A3L, Ledger to G.Letter
Capacity	: 3rd Drawer: 550 sheets (64 g/m ²)
Document Alignment	: Center baseline
Power Requirements	: DC 24 V \pm 10 % (supplied from the copier) DC 5 V \pm 5 %
Max. Power Consumption	: 15 W or less
Dimensions	: 570 (W) x 263 (H) x 548 (D) mm 22-1/2 x 10-1/4 x 21-1/2
Weight	: Approx. 27 kg (59-1/2 lbs)
Operating Environment	: Conforms to the operating environment of the copier.

2. Revolving Parts Layout Drawing

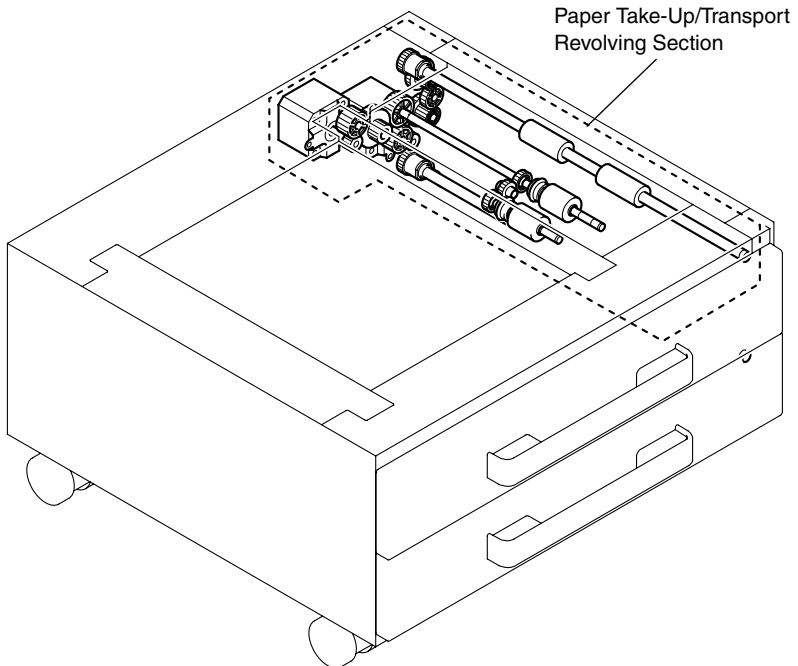

4348M005AA

3. Electric Parts Layout Drawing

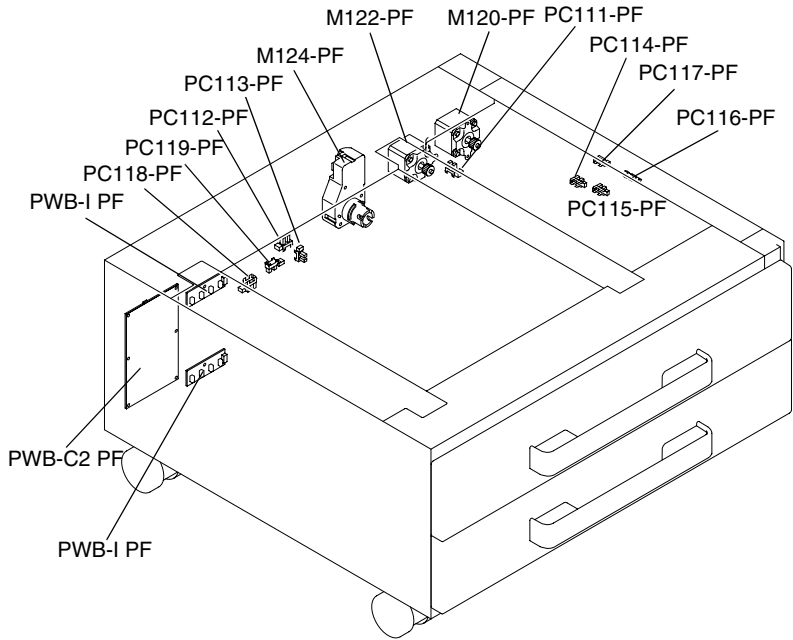

4348M006AA

Symbol	Name	Symbol	Name
PWB-C2 PF	Control Board	PC117-PF	3rd Drawer Vertical Transport Sensor
PWB-I PF	3rd Drawer FD Paper Size Detection Board	PC118-PF	3rd Drawer CD Paper Size Detecting Sensor 1
M120-PF	3rd Drawer Transport Roller Motor	PC119-PF	3rd Drawer CD Paper Size Detecting Sensor 2
M122-PF	3rd Drawer Paper Feed Motor		
M124-PF	3rd Drawer Lift-Up Motor		
PC111-PF	Door Set Sensor		
PC112-PF	3rd Drawer Set Sensor		
PC113-PF	3rd Drawer Paper Near-Empty Sensor		
PC114-PF	3rd Drawer Lift-Up Upper Limit Sensor		
PC115-PF	3rd Drawer Paper Empty Sensor		
PC116-PF	3rd Drawer Paper Take-Up Sensor		

DIS/REASSEMBLY, ADJUSTMENT



1. Maintenance Schedule

- To ensure that the copier produces good copies and to extend its service life, it is recommended that the maintenance jobs described in this schedule be carried out as instructed.

PM Parts	Job		Item Used for Cleaning	Qty	Ref. Page
	Clean	Repla ce			
Pickup Roller	○	300K	Alcohol and soft cloth	1	REF D-3,5
Paper Take-Up Roll	○	300K		1	REF D-3,5
Separator Roll Assy	○	300K		1	REF D-3,5
Vertical Transport Roller	○	—		1	REF D-6

NOTES

- K = 1,000 copies*
- Replace the Paper Take-Up Roller and Separator Roll at the same time.*
- indicates cleaning when transport failure occurs.*
- The contents of this maintenance schedule are subject to change without notice.*
- For part numbers, see Parts Manual and Parts Modification Notice.*

2. Disassembly and Cleaning

2-1. Removal of the Outer Cover

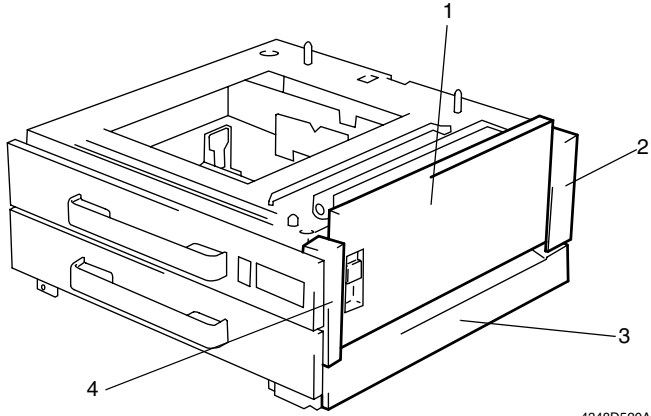

4348D520AA

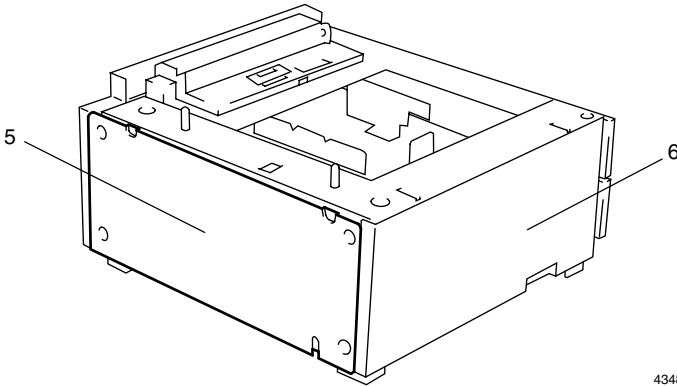

4348D015AA

No.	Name	Removal Procedure
1	Right Door	Open the Right Door. → Remove the Right Door.
2	Rear Right Cover	Remove two screws and the drawer.
3	Lower Right Cover	Remove two screws and the drawer.
4	Front Right Cover	Remove two screws and the drawer.
5	Rear Cover	Remove four screws and the cover.
6	Left Cover	Remove four screws and the cover.

2-2. Removal of the Pickup Roller/Take-Up Roller/Separator Roll Assy

1. Remove the Rear Right Cover.
2. Remove the Right Door.

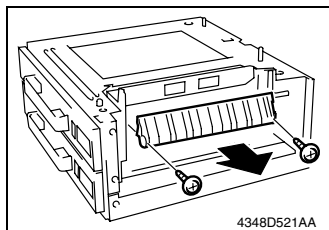

3. Remove two screws, and the guide plate.

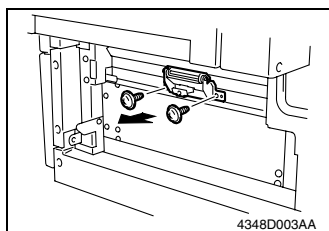

4. Remove two screws and the Paper Separator Roll Mounting Bracket Assy.

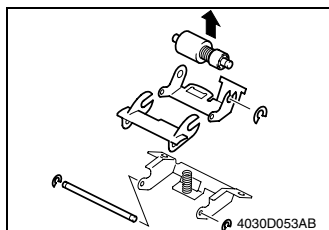

5. Remove three C rings and the Paper Separator Roll Assy.

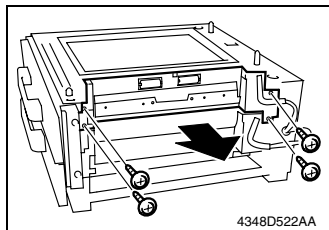

6. Remove four screws and the Paper Take-Up Unit.

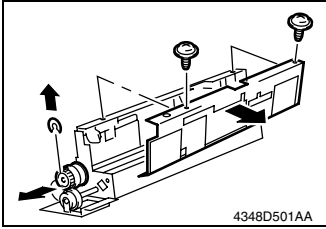

7. Remove two screws and the cover.
8. Remove one C-ring and remove the gear.

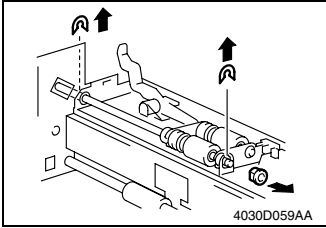

9. Remove two C-rings and remove the bushing.
10. Remove the Roll Assy.

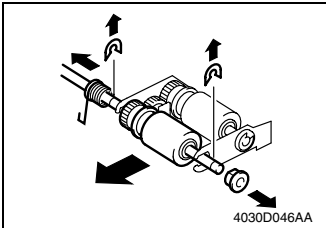

11. Remove two C-rings and remove the bushing.
12. Remove the Roll Assy.

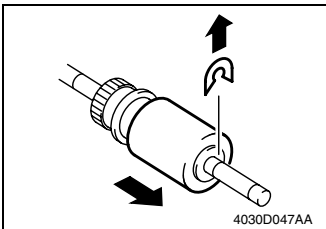

13. Remove one C-clip and remove the Paper Take-Up Roll.

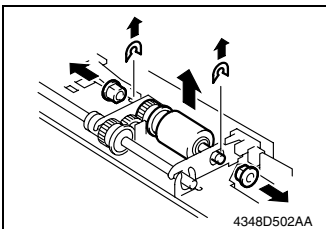

14. Remove two C-rings and remove the bushing.

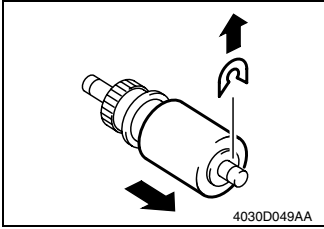

15. Remove one C-clip and remove the Pickup Roller.

Precaution for Reinstallation of the Separator Roll Assy

- Install the Separator Roll Assy while pressing the holder down so that it aligns to the metal bracket of the copier.

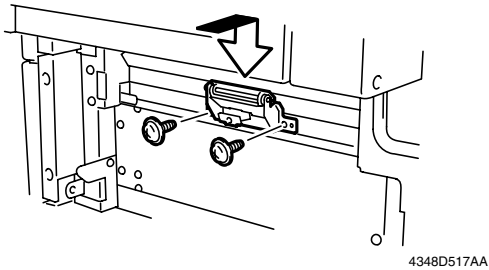

2-3. Cleaning of the Pickup Roller/Paper Take-Up Roller/Separator Roll

1. Remove the Rear Right Cover.
2. Remove the Right Door.
3. Remove two screws, and the guide plate.

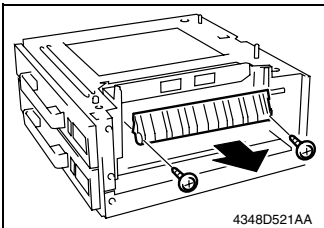

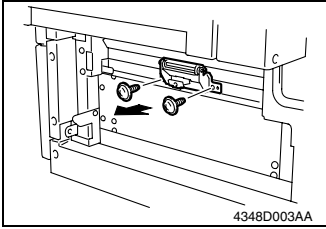

4. Remove two screws and the Paper Separator Roll Mounting Bracket Assy.

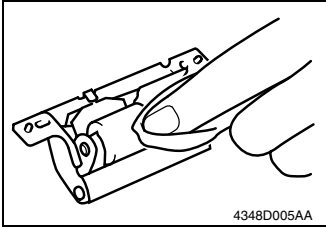

5. Using a soft cloth dampened with alcohol, wipe the Separator Roll clean of dirt.

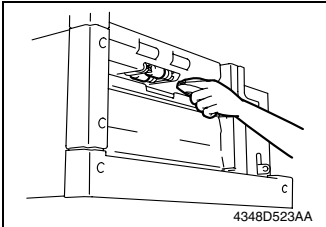

6. Using a soft cloth dampened with alcohol, wipe the Pickup Roller and Paper Take-Up Roller clean of dirt.

2-4. Cleaning of the Vertical Transport Roller

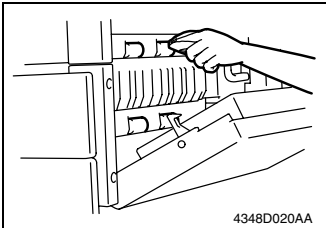

1. Open the Right Door.
2. Using a soft cloth dampened with alcohol, wipe the Vertical Transport Roller clean of dirt.

3. Adjustment

3-1. Registration CD

NOTE

Make this adjustment after any of the following procedures has been performed.

- When the PH Unit has been replaced.
- When the paper type has been changed.
- When the image on the copy is offset in the CD direction.
- When a faint image occurs on the leading edge of the image.

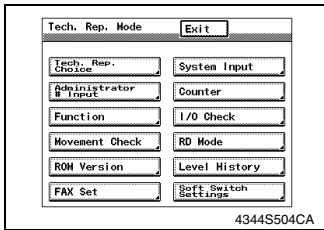

1. Display Tech. Rep. Mode.

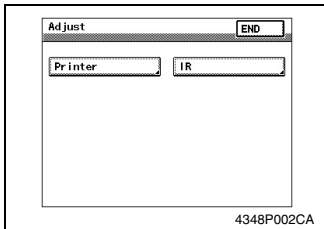

2. Press the Stop key followed by the Start key to display the Adjust Mode.
3. Touch the Printer key.

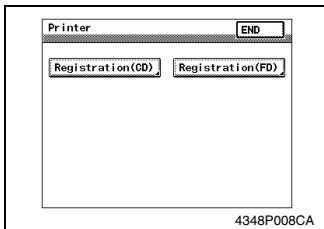

4. Touch the Registration (CD) key.

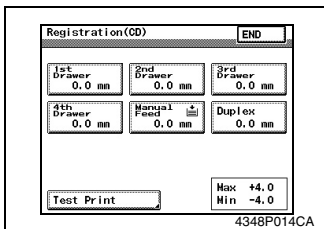

5. Touch the Test Print key.

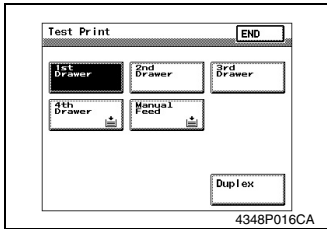

6. Touch the 3rd Drawer key.
7. Press the Start key.

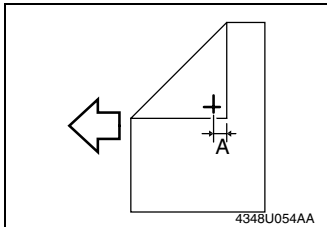

8. Measure the width of printed reference line A.
Specification: 10 mm \pm 2.0 mm
9. If width A falls within the specified range, finish the adjustment procedure.
If outside the specified range, perform the adjustment below.

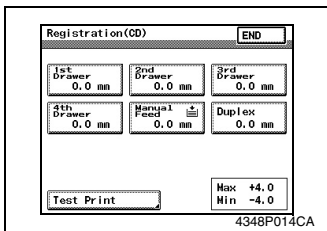

10. Touch END to display the Registration (CD) screen.
11. Touch the 3rd Drawer key.

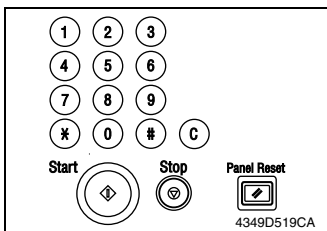

12. Press the Clear key and use the 10-Key Pad to set the value.
 - * If width A is wider than the specified range, enter a negative value.
 - * If width A is narrower than the specified range, enter a positive value.
- Adjustment range: + 4.0 max. and -4.0 min.
Use the * key to switch between + and -.

NOTE

- If width A falls outside the specified range, redo the adjustment from step 13.
-

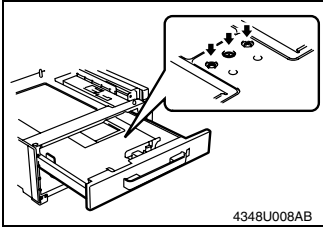

13. Slide out the Drawer and remove the paper.

14. Loosen three screws.

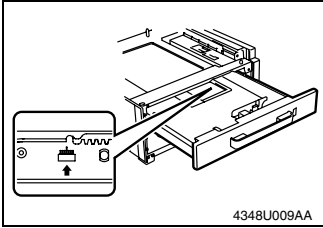

- If width A is wider than the specified range:
Move the Trail Edge Stop toward the front.
- If width A is narrower than the specified range:
Move the Trail Edge Stop toward the rear.

15. Perform another test print and check the reference deviation.

16. Repeat the adjustment until the reference line falls within the specified range.

17. After making the adjustment, tighten the three screws that were loosened at step 15.

3-2. Registration FD

NOTE

Make this adjustment after any of the following procedures has been performed.

- When the PH Unit has been replaced.
- When the paper type has been changed.
- When the image on the copy is offset in the FD direction.

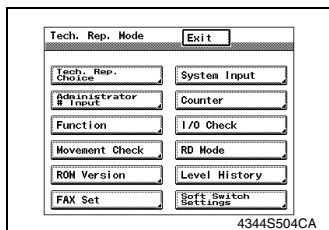

1. Display Tech. Rep. Mode.

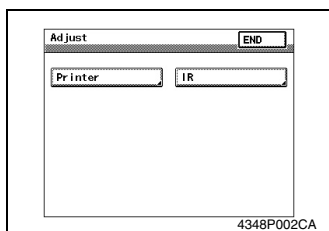

2. Press the Stop key followed by the Start key to display the Adjust Mode.

3. Touch the Printer key.

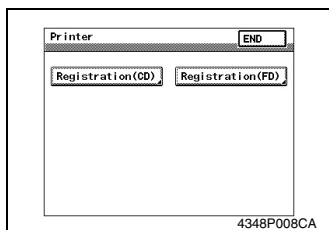

4. Touch the Registration (FD) key.

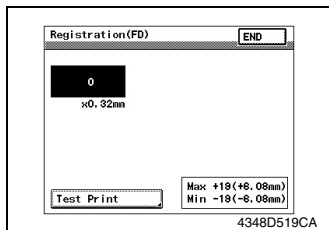

5. Touch the Test Print key.

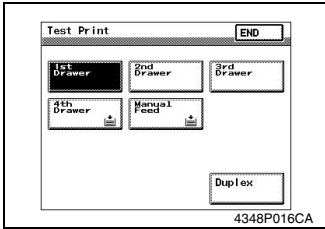

6. Touch the 3rd Drawer key.
7. Press the Start key.

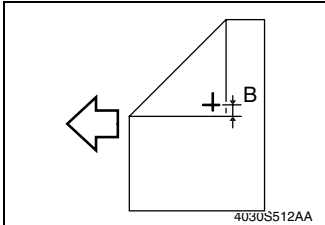

8. Measure the width of printed reference line B.
Specification: 11.3 mm±1.5 mm
9. If width B falls within the specified range, finish the adjustment procedure.
If outside the specified range, perform the adjustment below.

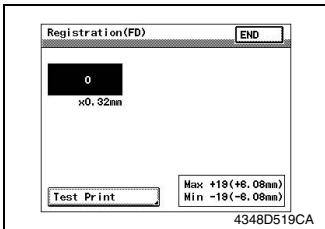

10. Touch END to display the Registration (FD) screen.
11. Touch the 3rd Drawer or 4th Drawer key.

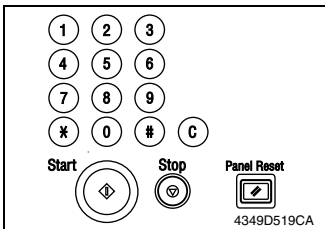

12. Press the Clear key and use the 10-Key Pad to set the value.
 - * If width B is wider than the specified range, enter a negative value.
 - * If width B is narrower than the specified range, enter a positive value.
 Adjustment range: + 4.0 max. and -4.0 min.

13. Perform another test print and check the reference deviation.
14. Repeat the adjustment until the reference line falls within the specified range.

TROUBLESHOOTING



1. Introduction

- Information required for troubleshooting and steps that must be performed are described in this chapter.

1-1. Electrical Components Check Procedure

- If a paper misfeed or malfunction occurs, perform the following operation to check the condition of the electrical components.

(1) Sensor

Step	Check	Result	Action
1	Does the input signal of the control board change when the sensor light is interrupted? (H → L, L → H)	NO	Replace the sensor.
		YES	Replace the control board.

The diagram illustrates the electrical connections for two sensors. On the left, the 4025T520AA sensor is shown with a 5-pin connector. The pins are labeled DCSV, PC ON, GND, and two unlabeled pins. On the right, the 4025T521AA sensor is shown with a 5-pin connector. The pins are labeled DCSV, PC ON, GND, and two unlabeled pins. The diagram shows the physical layout of the sensors and their respective wiring connections.

(2) Switch

Step	Check	Result	Action
1	Does the input signal (NO) of the control board change from L to H when the switch is turned on?	NO	Replace the switch.
		YES	Replace the control board.

4025T523AB

(3) Solenoid

Step	Check	Result	Action
1	Does the output signal of the control board change from H to L when the solenoid is activated?	NO	Replace the control board.
		YES	Replace the solenoid.

4025T522AA

(4) Clutch

Step	Check	Result	Action
1	Does the output signal of the control board change from H to L when the clutch is activated?	NO	Replace the control board.
		YES	Replace the clutch.

4025T528AA

(5) Motor

Step	Check	Result	Action
1	Does the LOCK signal of the control board switch to H when the machine goes into standby?	NO	Replace the control board. Replace the motor.
		YES	Replace the motor.
2	Does the REM signal of the control board change from H to L when the motor is turned on?	NO	Replace the control board.

4025T526AA

Step	Check	Result	Action
1	Does the input signal of the control board change from H to L when the motor is turned on? (Input signals differ according to the direction of rotation)	YES	Replace the motor.
		NO	Replace the control board.

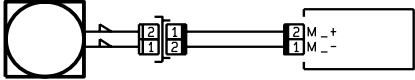

4025T525AA

Step	Check	Result	Action
1	Are the relay connector of the motor and the print jack of the control board correctly connected?	YES	Replace the motor or the control board.
		NO	Connect the connector or the print jack.

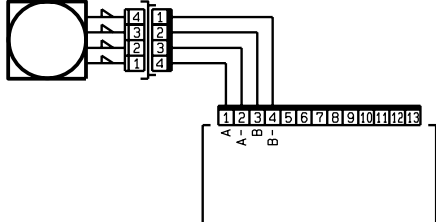

4025T527AA

2. I/O CHECK

- For an easy and safe operation check of the sensors, the sensor input data is checked when the copier is in standby (including when a misfeed or a malfunction occurs or when a part is not correctly closed) to determine if signals are properly input.
1. Display the Tech. Rep. Mode screen.
 2. Touch [I/O CHECK].
 3. Touch [Printer].
 4. Touch the button for the 3rd paper drawer.
 5. Using a sheet of paper, activate the sensor and check the display in the Touch Panel.
(Paper present: 1; Paper not present: 0)

<3rd Drawer>

3rd Drawer		END	
Drawer Set	0	Pickup	0
Paper	0		
Near Empty	0		
Paper Empty	0		
Surface	0		
CD Size 1	0		
CD Size	0		
FD Size 1	0		
FD Size 2	0		
FD Size 3	0		
FD Size 4	0		
Take-up Lower	0		

4348T504CA

2-1. I/O Check List

<3rd Drawer>

Symbol	Panel Display	Parts/Signal Name	Operation Characteristics/ Panel Display		Input Board	CN/PJ No.
			1	0		
PC112-PF	Drawer Set	3rd Drawer Set Sensor	Set	Out of position	Control Board (PWB-C2 PF)	PJ3C2 PF-9
PC113-PF	Paper Near Empty Sensor	3rd Drawer Paper Near-Empty Sensor	Unblocked	Blocked		PJ4C2 PF-3
PC115-PF	Paper Empty Sensor	3rd Drawer Paper Empty Sensor	Paper not present	Paper present		PJ6C2 PF-6
PC114-PF	Top Detector	3rd Drawer Lift-Up Upper Limit Sensor	Raised Position	Not raised		PJ6C2 PF-3
PC118-PF	CD Size Detecting 1	3rd Drawer CD Paper Size Detecting Sensor 1	Maximum value	Not at maximum value		PJ3C2 PF-3
PC119-PF	CD Size Detecting 2	3rd Drawer CD Paper Size Detecting Sensor 2	Maximum value	Not at maximum value		PJ3C2 PF-6
PWB-I PF	FD Size Detecting 1	3rd Drawer FD Paper Size Detecting Board	Maximum value	Not at maximum value		PJ3C2 PF-10
	FD Size Detecting 2		Maximum value	Not at maximum value		PJ3C2 PF-11
	FD Size Detecting 3		Maximum value	Not at maximum value		PJ3C2 PF-12
	FD Size Detecting 4		Maximum value	Not at maximum value		PJ3C2 PF-13
PC111-PF	Cabinet Cover	Door Set Sensor	Open	Closed	PJ6C2 PF-15	
PC116-PF	Pick-Up	3rd Drawer Paper Take-Up Sensor	Paper present	Paper not present	PJ6C2 PF-8	

3. Misfeed Detection/Troubleshooting Procedures

3-1. Initial Checks

- When a paper misfeed occurs, first perform the following initial checks.

Check Item	Action
Does paper meet product specifications?	Replace paper.
Is the paper curled, wavy, or damp?	Replace paper. Instruct the user on the correct paper storage procedures.
Is a foreign object present along the paper path, or is the paper path deformed or worn?	Remove object or replace the defective paper path.
Are the Paper Separator Fingers dirty, deformed, or worn?	Clean or replace the defective Paper Separator Finger.
Are rolls/rollers dirty, deformed, or worn?	Clean or replace the defective roll/roller.
Are the Edge Guide and Trailing Edge Stop at the correct position to accommodate the paper?	Set as necessary.
Are the actuators operating correctly?	Correct or replace the defective actuator.

3-2. Misfeed-Detecting Sensor Layout

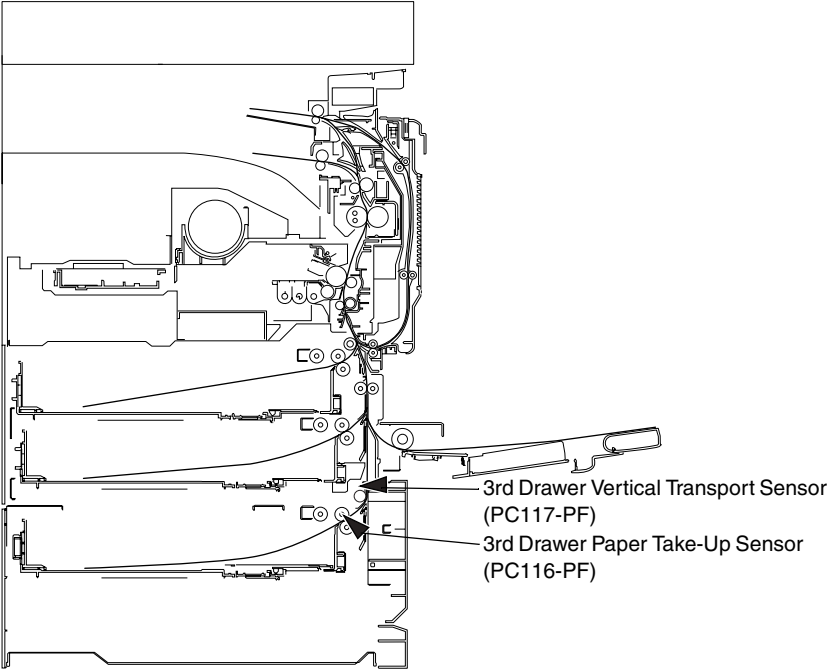

4348T508AA

3-3. Misfeed Detected

When a paper misfeed occurs, the misfeed message, misfeed location (⊗), and paper location (○) are displayed on the Touch Panel of the copier.

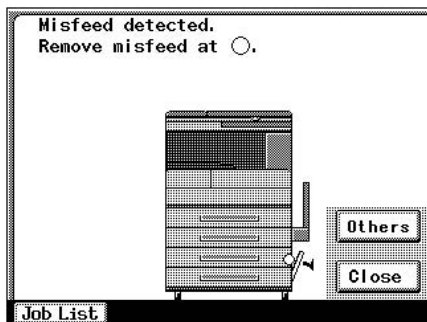

4348T507CA

3-4. Misfeed Detection Timing/Troubleshooting Procedures

(1) Paper Take-Up Misfeed





<3rd Drawer>

<Detection Timing>

Type	Description
Paper Take-Up Section misfeed detection	The leading edge of the paper does not block the 3rd Drawer Vertical Transport Sensor (PC117-PF) even after the set period of time has elapsed after the 3rd Drawer Paper Feed Motor is energized.
Detection of paper remaining in the Paper Take-Up section	The 3rd Drawer Vertical Transport Sensor (PC117-PF) is blocked when the Power Switch is set to ON, a door or cover is opened and closed, or a misfeed or malfunction is reset.
	The 3rd Drawer Paper Take-Up Sensor (PC116-PF) is blocked when the Power Switch is set to ON, a door or cover is opened and closed, or a misfeed or malfunction is reset.

Action

Relevant Electrical Components	
3rd Drawer Vertical Transport Sensor (PC117-PF) 3rd Drawer Paper Take-Up Sensor (PC116-PF) 3rd Drawer Paper Feed Motor (M122-PF)	Control Board (PWB-C2 PF)

Step	Operations	Ref. Page	WIRING DIAGRAM	
			Control signal	Location (Electrical Components)
1	Initial checks	 T-7	—	—
2	PC117-PF sensor check	 T-1	PWB-C2 PF PJ6C2 PF-11	F-2
3	PC116-PF sensor check	 T-1	PWB-C2 PF PJ6C2 PF-8	F-3
4	M122-PF operation check	 T-3	—	E-2
5	PWB-C2 PF replacement	—	—	D-5

4. Malfunction Detection/Troubleshooting Procedure

4-1. Malfunction Detection

- If any of the following incorrect operations are detected, the corresponding malfunction code appears on the copier's Touch Panel.
- To cancel the malfunction, open, then close the copier's Front Door.

Code	Description	Detection Timing
C0900	3rd Drawer Lift-Up Motor Failure	The Lift-Up Sensor is not blocked even after the set period of time has elapsed after the paper lift-up operation for the drawer began.



(1) C0900: 3rd Drawer Lift-Up Motor Failure

<Detection Timing>

Malfunction Code	Description
C0900	The Lift-Up Sensor is not blocked even after the set period of time has elapsed after the paper lift-up operation for the drawer began.

Action

Relevant Electrical Components	
Lift-Up Motor 1 (M124-PF) Lift-Up Sensor 1 (PC114-PF)	Control Board (PWB-C2 PF) Copier Master Board (PWB-A) Copier Power Supply Unit (PU1)

Step	Operations	Ref. Page	WIRING DIAGRAM	
			Control signal	Location (Electrical Components)
1	Check the connectors of each motor and sensor for proper connection, and correct as necessary.	—	—	—
2	Check the connector of each motor for proper drive coupling, and correct as necessary.	—	—	—
3	Check the PU1 connector for proper connection, and correct as necessary.	—	—	—
4	PC114-PF sensor check	 T-1	PWB-C2 PF PJ6C2 PF-3	G-3
6	M124-PF operation check	 T-3	PWB-C2 PF PJ4C2 PF-5,4	D-3
8	PWB-C2 PF replacement	—	—	E-5
9	PWB-A replacement	—	—	—
10	PU1 replacement	—	—	—