

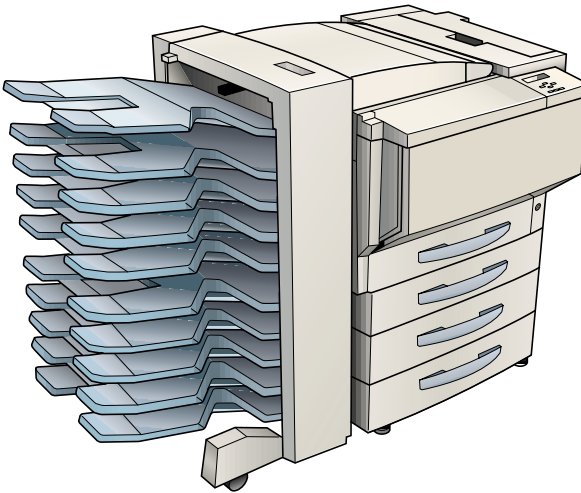

CF2001P

User Manual



If used as a MicroPress printer, refer to the manual in the Minolta MicroPress Cluster Printing System server.



Energy Star®

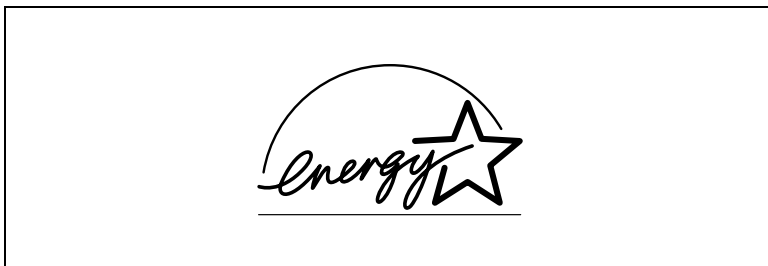

As an ENERGY STAR® Partner, we have determined that this machine meets the ENERGY STAR® Guidelines for energy efficiency.

What is an ENERGY STAR® Product?

An ENERGY STAR® product has a special feature that allows it to automatically switch to a “low-power mode” after a period of inactivity. An ENERGY STAR® product uses energy more efficiently, saves you money on utility bills and helps protect the environment.

Trademarks and Registered Trademarks

Fiery and the Fiery logo are registered trademarks of Electronics for Imaging, Inc.

Fiery X3e is a trademark of Electronics for Imaging, Inc.

T/R Systems, MicroPress and other T/R Systems’ product names are either trademarks or registered trademarks of T/R Systems, Inc. in the United States and other countries.

DiALTA and NMT are registered trademarks of Minolta Co., Ltd.

All other product names mentioned are trademarks or registered trademarks of their respective companies.

Contents

1 Introduction

1.1	We Want You to Be a Satisfied Customer	1-1
1.2	SAFETY INFORMATION.....	1-1
	Warning and Precaution Symbols.....	1-2
	Meaning of Symbols.....	1-2
	WARNING.....	1-2
	CAUTION.....	1-4
	Precautions for Routine Use	1-5
	USER INSTRUCTIONS	
	FCC PART 15 - RADIO FREQUENCY DEVICES	
	(For U.S.A. Users).....	1-6
	INTERFERENCE-CAUSING EQUIPMENT STANDARD	
	(ICES-003 ISSUE 3) (For Canada Users).....	1-6
	CE Marking (Declaration of Conformity) for Users of the European Union (EU)	1-6
	For users in countries subject to Class B regulations	1-7
	For users in countries not subject to Class B regulations	1-7
	Ozone Release	1-7
	WARNING LABEL.....	1-8
	LED Radiation Safety.....	1-8
1.3	Guide to Manuals	1-9
	Enclosed Manuals.....	1-9
	Explanation of Manual Conventions.....	1-9
1.4	Explanation of Basic Concepts and Symbols	1-11
	Paper Feeding.....	1-11
	“Width” and “Length”	1-12
	Paper Orientation	1-12
1.5	Features	1-13

2 Precautions

2.1	Installation Precautions.....	2-1
	Installation site	2-1
	Power source	2-1
	Space requirements.....	2-2
2.2	Operation Precautions.....	2-3
	Operating environment.....	2-3
	Proper use.....	2-3

Transporting the printer	2-4
Care of printer supplies	2-4

3 Before Making Prints

3.1 Components and Their Functions	3-1
3.2 Parts Names and Their Functions	3-4
Outside of Printer.....	3-4
Inside of Printer	3-6
Supplies and Parts	3-7
Duplex Unit (Optional)	3-8
10-Mailbin Sorter (Optional)	3-9
Finisher (Optional).....	3-10
Paper Feed Unit (Optional).....	3-11
Large-Capacity Cabinet (Optional).....	3-12
Printer Controller Fiery X3e	3-12
Printer Controller MicroPress PrintLink 2020m	3-12
3.3 Names of Control Panel Parts and Their Functions.....	3-13
Names of Control Panel Parts and Their Functions	3-13
3.4 Power Switch	3-14
Turning the printer on and off	3-14
To turn the printer on	3-14
To turn the printer off	3-14
Turning On the Printer	3-15
Turning Off the Printer	3-16
To turn off the printer	3-16
3.5 Total Counter	3-18
To print the total counter.....	3-18

4 Print Paper

4.1 Paper Specifications	4-1
Paper Types	4-1
Paper Sizes	4-2
Paper Types To Be Avoided.....	4-5
4.2 Print Area	4-6
4.3 Paper Storage	4-6
4.4 Loading Paper.....	4-7
To load paper into Tray 1 (250-sheet multipurpose tray)	4-7
To set the paper size for Tray 1.....	4-11
To load paper into Tray 2 or the 500-sheet paper feed unit	4-12
To load paper into the large-capacity cabinet.....	4-14
To load paper into the manual bypass tray	4-16

5 Control Panel Messages

5.1	Message List	5-1
	To load paper into Tray 1 (250-sheet multipurpose paper drawer)	5-4
	To load paper into Tray 2 or the 500-sheet paper feed unit.....	5-5
	To load paper into the large-capacity cabinet	5-7
5.2	When the Message “Xxxx toner nearly empty” Appears	5-8
	To add toner.....	5-9
5.3	When the Message “No xxxx staples” Appears	5-12
	To replace the staple cartridge.....	5-12
5.4	Clearing a Paper Misfeed and Staple Jam	5-16
	To clear a paper misfeed in the manual bypass tray	5-18
	To clear a paper misfeed in the duplex unit	5-20
	To clear a paper misfeed in the paper feed unit.....	5-21
	To clear a paper misfeed in the printer	5-23
	To clear a paper misfeed in finisher FN-107/FN-108	5-26
	To clear a paper misfeed in the 10-mailbin sorter	5-30
	To clear jammed staples	5-33
5.5	When the Message “Service Code Cxxxx” Appears	5-36
5.6	When the Message “xxxx unit near life limit” Appears	5-37
5.7	When the Message “Near trouble XX/XX” Appears	5-38

6 Troubleshooting

6.1	Improving Print Quality	6-1
------------	--------------------------------------	------------

7 Appendix

7.1	Specifications	7-1
	Printer CF2001P	7-1
	500-sheet Paper Feed Unit PF-118	7-2
	Large-capacity Cabinet PF-117	7-3
	Duplex Unit AD-14	7-3
	10-Mailbin Sorter JS-1002	7-4
	Finisher FN-107	7-5
	Finisher FN-108	7-6
7.2	Care of the Printer	7-7
	Cleaning	7-7
	Housing cover	7-7
	Control panel.....	7-7

8 Index



1 Introduction

1.1 We Want You to Be a Satisfied Customer

Thank you for choosing a Minolta CF2001P.

To ensure the best performance and effective use of your printer, this manual will provide information on the following topics:

- Getting to Know Your printer.
- Initial Steps . . .
- Troubleshooting.

Please read this manual carefully before using your printer and keep it handy at all times. Store the manual in the holder on the rear side of the printer.

1.2 SAFETY INFORMATION



This section contains detailed instructions on the operation and maintenance of this machine. To achieve optimum utility of this device, all operators should carefully read and follow the instructions in this manual. Please keep this manual in a handy place near the machine.

Please read the next section before using this device. It contains important information related to user safety and preventing equipment problems.

Make sure you observe all of the precautions listed in this manual.

* Please note that some parts of the contents of this section may not correspond with the purchased product.

Warning and Precaution Symbols

 WARNING:	Ignoring this warning could cause serious injury or even death.
 CAUTION:	Ignoring this caution could cause injury or damage to property.

Meaning of Symbols



A triangle indicates a danger against which you should take precaution.



This symbol warns against possible electrical shock.



A diagonal line indicates a prohibited course of action.



This symbol warns against dismantling the device.



A black circle indicates an imperative course of action.



This symbol indicates you must unplug the device.

WARNING



- Do not modify this product, as a fire, electrical shock, or breakdown could result. If the product employs a laser, the laser beam source could cause blindness.
- Do not attempt to remove the covers and panels which have been fixed to the product. Some products have a high-voltage part or a laser beam source inside that could cause an electrical shock or blindness.







- Only use the power cord supplied in the package. Failure to use this cord could result in a fire or electrical shock.
- Use only the specified power source voltage. Failure to do that could result in a fire or electrical shock.
- Do not use a multiple outlet adapter to connect any other appliances or machines. Use of a power outlet for more than the marked current value could result in a fire or electrical shock.



Do not unplug and plug in the power cord with a wet hand, as an electrical shock could result.



Plug the power cord all the way into the power outlet. Failure to do this could result in a fire or electrical shock.

	<ul style="list-style-type: none">• Do not scratch, abrade, place a heavy object on, heat, twist, bend, pull on, or damage the power cord. Use of a damaged power cord (exposed core wire, broken wire, etc.) could result in a fire or breakdown. Should any of these conditions be found, immediately turn OFF the power switch, unplug the power cord from the power outlet, and then call your authorized service representative.• In principle, do not use an extension cord. Use of an extension cord could cause a fire or electrical shock. Contact your authorized service representative if an extension cord is required.
	<p>Do not place a flower vase or other container that contains water, or metal clips or other small metallic objects on this product. Spilled water or metallic objects dropped inside the product could result in a fire, electrical shock, or break-down.</p> <p>Should a piece of metal, water, or any other similar foreign matter get inside the product, immediately turn OFF the power switch, unplug the power cord from the power outlet, and then call your authorized service representative.</p>
	<ul style="list-style-type: none">• If this product becomes inordinately hot or emits smoke, or unusual odor or noise, immediately turn OFF the power switch, unplug the power cord from the power outlet, and then call your authorized service representative. If you keep on using it as is, a fire or electrical shock could result.• If this product has been dropped or its cover damaged, immediately turn OFF the power switch, unplug the power cord from the power outlet, and then call your authorized service representative. If you keep on using it as is, a fire or electrical shock could result.
	<p>Do not throw the toner cartridge or toner into an open flame. The hot toner may scatter and cause burns or other damage.</p>
	<p>Connect the power cord to an electrical outlet that is equipped with a grounding terminal.</p>

CAUTION

- Do not use flammable sprays, liquids, or gases near this product, as a fire could result.
- Do not leave a toner unit or drum unit in a place within easy reach of children.
Licking or ingesting any of these things could injure your health.
- Do not let any object plug the ventilation holes of this product. Heat could accumulate inside the product, resulting in a fire or malfunction.
- Do not install this product at a site that is exposed to direct sunlight, or near an air conditioner or heating apparatus. The resultant temperature changes inside the product could cause a malfunction, fire, or electrical shock.
- Do not place the product in a dusty place, or a site exposed to soot or steam, near a kitchen table, bath, or a humidifier. A fire, electrical shock, or breakdown could result.
- Do not place this product on an unstable or tilted bench, or in a location subject to a lot of vibration and shock. It could drop or fall, causing personal injury or mechanical breakdown.
- After installing this product, mount it on a secure base. If the unit moves or falls, it may cause personal injury.
- Do not store toner units and PC drum units near a floppy disk or watch that are susceptible to magnetism. They could cause these products to malfunction.



The inside of this product has areas subject to high temperature, which may cause burns. When checking the inside of the unit for malfunctions such as a paper misfeed, do not touch the locations (around the fusing unit, etc.) which are indicated by a "Caution! High Temperature!" warning label.



Do not place any objects around the power plug as the power plug may be difficult to pull out when an emergency occurs.



- Always use this product in a well ventilated location. Operating the product in a poorly ventilated room for an extended period of time could injure your health. Ventilate the room at regular intervals.
- Whenever moving this product, be sure to disconnect the power cord and other cables. Failure to do this could damage the cord or cable, resulting in a fire, electrical shock, or breakdown.
- When moving this product, always hold it by the locations specified in the user manual or other documents. If the unit falls it may cause severe personal injury. The product may also be damaged or malfunction.
- Remove the power plug from the outlet more than one time a year and clean the area between the plug terminals. Dust that accumulates between the plug terminals may cause a fire.
- When unplugging the power cord, be sure to hold onto the plug. Pulling on the power cord could damage the cord, resulting in a fire or electrical shock.

Precautions for Routine Use



- Do not store toner units, PC drum units, and other supplies and consumables in a place subject to direct sunlight and high temperature and humidity, as poor image quality and malfunction could result.
- Do not attempt to replace the toner unit and PC drum unit in a place exposed to direct sunlight. If the PC drum is exposed to intense light, poor image quality could result.
- Do not unpack a toner unit or PC drum unit until the very time of use. Do not leave an unpacked unit standing. Install it immediately or poor image quality could result.
- Do not keep toner units and PC drum units in an upright position or upside down, as poor image quality could result.
- Do not throw or drop a toner unit or PC drum unit as poor image quality could result.
- Do not use this product in an area where ammonia or other gases or chemicals are present. Failure to do so may shorten the service life of the product, cause damage or decrease performance.
- Do not use this product in an environment with a temperature outside the range specified in the user manual, as a breakdown or malfunction could result.
- Do not attempt to feed stapled paper, carbon paper or aluminum foil through this product, as a malfunction or fire could result.



Do not touch or scratch the surface of the toner unit developing roller and the PC drum, as poor image quality could result.



Use the supplies and consumables recommended by the dealer. Use of any supply or consumable not recommended could result in poor image quality and breakdown.

USER INSTRUCTIONS

FCC PART 15 - RADIO FREQUENCY DEVICES (For U.S.A. Users)

NOTE: This equipment has been tested and found to comply with the limits for a Class A digital device, pursuant to Part 15 of the FCC Rules. These limits are designed to provide reasonable protection against harmful interference when the equipment is operated in a commercial environment. This equipment generates, uses and can radiate radio frequency energy and, if not installed and used in accordance with the instruction manual, may cause harmful interference to radio communications. Operation of this equipment in a residential area is likely to cause harmful interference in which case the user will be required to correct the interference at his own expense.

WARNING: The design and production of this unit conform to FCC regulations, and any changes or modifications must be registered with the FCC and are subject to FCC control. Any changes made by the purchaser or user without first contacting the manufacturer will be subject to penalty under FCC regulations.

This device must be used with a shielded interface (Parallel) cable and shielded network (10/100BaseT) cable. The use of non-shield cables is likely to result in interference with radio communications and is prohibited under FCC rules.

INTERFERENCE-CAUSING EQUIPMENT STANDARD (ICES-003 ISSUE 3) (For Canada Users)

This Class A digital apparatus complies with Canadian ICES-003.

Cet appareil numérique de la classe A est conforme à la norme NMB-003 du Canada.

CE Marking (Declaration of Conformity) for Users of the European Union (EU)

This product complies with the following EU directives: 89/336/EEC, 73/23/EEC and 93/68/EEC directives.

This declaration is valid for the area of the European Union.

This device must be used with a shielded interface (Parallel) cable and shielded network (10/100BaseT) cable. The use of non-shield cables is likely to result in interference with radio communications and is prohibited under 89/336/EEC rules.

For users in countries subject to Class B regulations

This device must be used with shielded interface (Parallel) cable and shielded network (10/100Base-T) cable.

The use of non-shield cables is likely to result in interference with radio communications and is prohibited under CISPR 22 and local rules.

For users in countries not subject to Class B regulations**WARNING**

This is a Class A product. In a domestic environment this product may cause radio interference in which case the user may be required to take adequate measures.

This device must be used with shielded interface (Parallel) cable and shielded network (10/100Base-T) cable.

The use of non-shield cables is likely to result in interference with radio communications and is prohibited under CISPR 22 and local rules.

Ozone Release

Locate the machine in a Well Ventilated Room

A negligible amount of ozone is generated during normal operation of this machine. An unpleasant odor may, however, be created in poorly ventilated rooms during extensive machine operations. For a comfortable, healthy and safe operating environment, it is recommended that the room be well ventilated.

Placer l'appareil dans une pièce largement ventilée

Une quantité d'ozone négligeable est dégagée pendant le fonctionnement de l'appareil quand celui-ci est utilisé normalement. Cependant, une odeur désagréable peut être ressentie dans les pièces dont l'aération est insuffisante et lorsque une utilisation prolongée de l'appareil est effectuée. Pour avoir la certitude de travailler dans un environnement réunissant des conditions de confort, santé et de sécurité, il est préférable de bien aérer la pièce où se trouve l'appareil.

WARNING LABEL

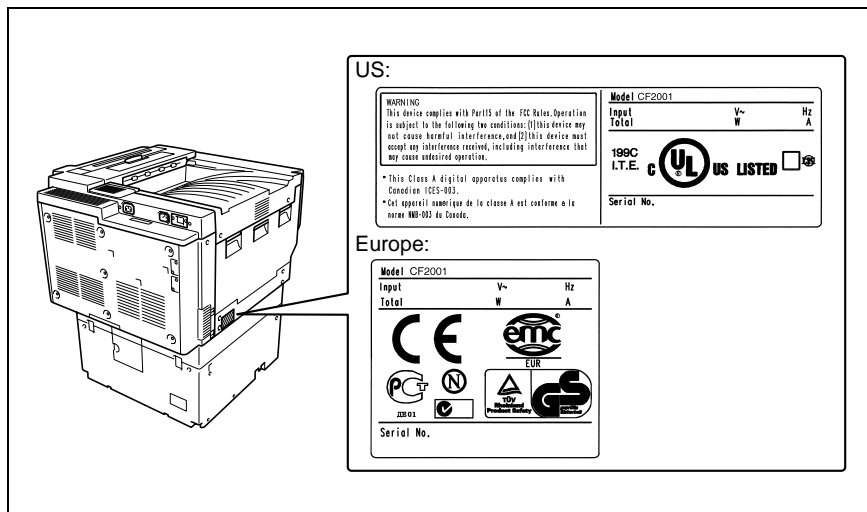
**CAUTION**

Install this machine so that it can quickly be unplugged from the electrical outlet in case of an emergency.

→ The socket-outlet shall be installed near the machine and shall be easily accessible.

LED Radiation Safety

This product is a printer which operates by means of a LED (light emitting diodes) exposure system. There is no possibility of danger from the LED optical radiation, because the LED optical radiation level does not exceed the accessible radiation limit of class 1 under all conditions of operation, maintenance, service and failure.

1.3 Guide to Manuals

Enclosed Manuals

In order to refer to the User Manual quickly when necessary, store it near the printer.

- User Manual

The User Manual describes the functions, operating procedures, precautions, and basic troubleshooting for this printer. Before using this printer, be sure to read the User Manual thoroughly in order to ensure that the printer operates properly and is used efficiently.

Explanation of Manual Conventions

The marks and text formats used in this manual are described below.



WARNING

Failure to observe instructions highlighted in this manner may result in fatal or critical injuries.

→ Observe all warnings in order to ensure safe use of the printer.



CAUTION

Failure to observe instructions highlighted in this manner may result in serious injuries or property damage.

→ Observe all cautions in order to ensure safe use of the printer.

**Note**

*(*May also appear as "Important" or "Tip")*

Text highlighted in this manner contains useful information and tips to ensure safe use of the printer.

- 1 The number 1 as formatted here indicates the first step of a sequence of actions.
- 2 Subsequent numbers as formatted here indicate subsequent steps of a sequence of actions.

? *Text formatted in this style provides additional assistance.*

→ Text formatted in this style describes the action that will ensure the desired results are achieved.

An illustration inserted here shows what operations must be performed.

1.4 Explanation of Basic Concepts and Symbols

The use of words and symbols in this manual are explained below.

Paper Feeding

During printing, paper is supplied from the right side of the printer and fed into the output tray on top or the output option at the left with the printed surface of the page facing down. The paper feed direction is shown by the arrows in the diagram below.

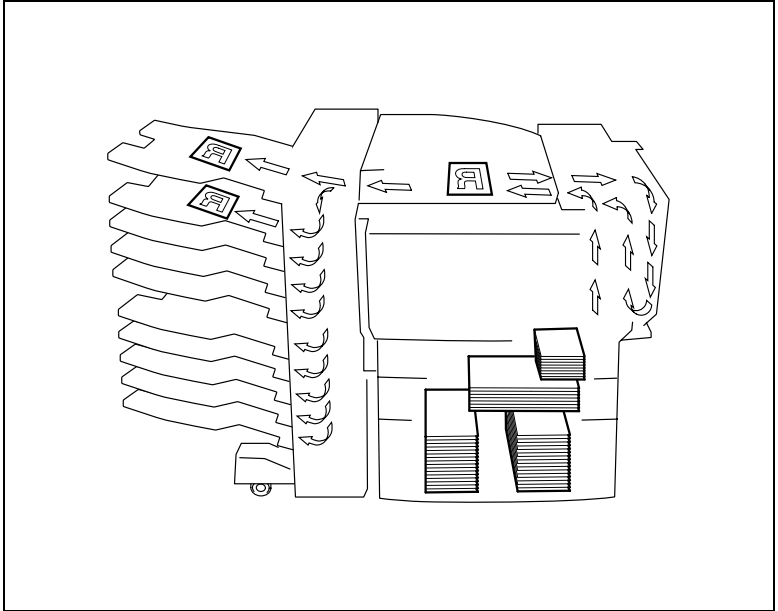

“Width” and “Length”

Whenever paper dimensions are mentioned in this manual, the first value always refers to the width of the paper (shown as “A” in the illustration) and the second to the length (shown as “B”).

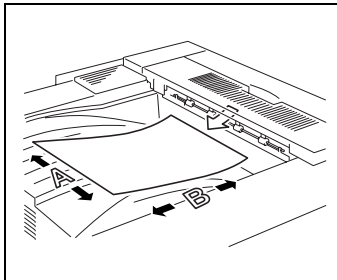

Paper Orientation

Lengthwise ()

If the width (A) of the paper is shorter than the length (B), the paper has a vertical or portrait orientation, indicated by either “L” or .

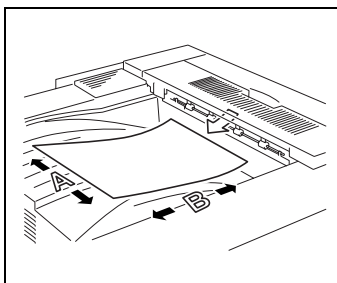

Crosswise ()

If the width (A) of the paper is longer than the length (B), the paper has a horizontal or landscape orientation, indicated by either “C” or .

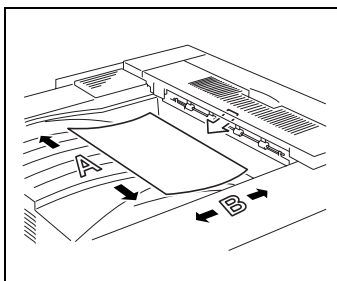

1.5 Features

The Minolta CF2001P is a high-speed, high-quality full-color printer, combining the functionality and compactness best suited for any office.

- Delivers high-speed, high-quality full-color printouts
High-quality, business-standard images with a resolution of 600 dpi x 600 dpi (simulated)/256 variations
High-speed full-color printing (Letter/A4 landscape/continuous printing) at 20 sheets per minute
- Combines handling of a large paper capacity in a compact design:
Lightweight, space-saving full-color printer
Maximum paper capacity of 3,250 sheets (including optional paper cassettes)
- Can be combined with a wide variety of options:
10-mailbin sorter, paper feed unit, and duplex unit, etc., providing even more features

2 Precautions

2.1 Installation Precautions

Installation site

To ensure utmost safety and prevent possible malfunctions, install the printer in a location that meets the following requirements.

- A location away from curtains, etc. that may catch fire and burn easily
- A location that is not exposed to water or other liquids
- A location free from direct sunlight
- A location out of the direct airflow of an air conditioner or heater, and not exposed to extremely high or low temperatures
- A well-ventilated location
- A location that is not exposed to high humidity
- A location that is not extremely dusty
- A location not subjected to undue vibrations
- A stable and level location
- A location where ammonia or other organic gases are not generated
- A location that does not place the operator in the direct airflow of exhaust from the printer
- A location that is not near any kind of heating devices

Power source

The power source requirements are as follows.

- Voltage fluctuation: Maximum $\pm 10\%$
(AC 127 V areas only: between -10% and +6%)
- Frequency fluctuation: Maximum $\pm 0.3\%$
- Use a power source with as little voltage or frequency fluctuations as possible.

Space requirements

To ensure easy printer operation, supply replacement, and maintenance, adhere to the recommended space requirements detailed below.

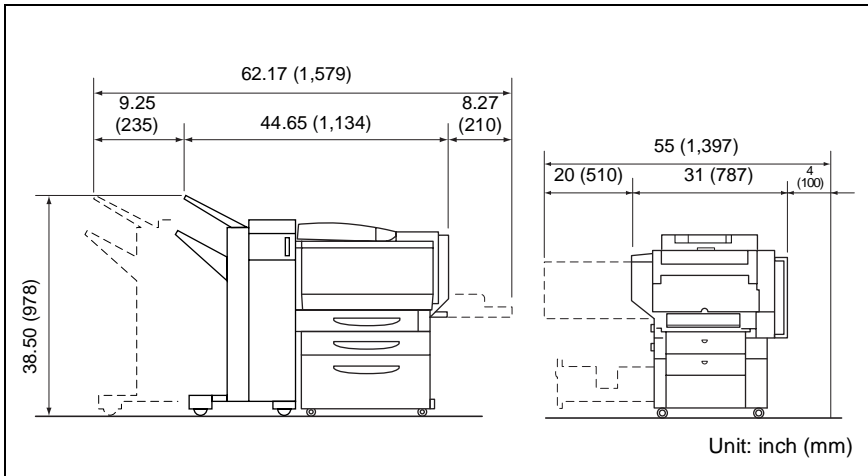
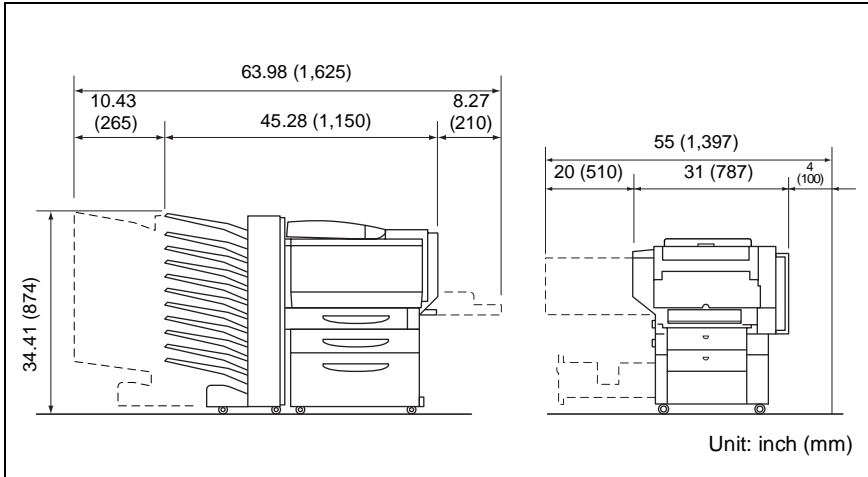

Note

Be sure to allow a clearance of 4 in. (100 mm) or more at the back of the printer for the ventilation duct.

2.2 Operation Precautions

Operating environment

The environmental requirements for correct operation of the printer are as follows.

- Temperature: 50°F (10°C) to 86°F (30°C) with fluctuations of no more than 18°F (10°C) within an hour
- Humidity: 25% to 85% with fluctuations of no more than 20% within an hour

Proper use

To ensure the optimum performance of the printer, follow the precautions listed below.

- Never open any printer doors or turn off the printer while it is printing; otherwise, a paper jam will occur.
- Never bring any magnetized object or use flammable sprays or liquids near the printer.
- + Always make sure that the power plug is completely plugged into the electrical outlet.
- Always make sure that the printer's power plug is visible and not hidden by the printer.
- + Always unplug the printer from the electrical outlet if the unit is not to be used for a long period of time.
- + Always provide good ventilation when making a large number of continuous prints.



CAUTION

A negligible amount of ozone is generated during normal operation of this printer. An unpleasant odor may, however, be detected in poorly ventilated rooms during extensive printer operations.

- For a comfortable operating environment, it is recommended that the room be well ventilated.
-



CAUTION

If the ventilation duct at the top of the printer becomes blocked, the inside of the printer will accumulate heat, resulting in a malfunction or fire.

- Do not place any objects over the ventilation duct.
-



CAUTION

The area around the fusing unit is extremely hot.

- Be careful not to touch any parts around the fusing unit, other than those indicated in this manual, in order to reduce the risk of burns. Be especially careful not to touch parts marked with warning labels, and their surrounding areas.
 - If you get burnt, immediately cool the skin under cold water, and then seek professional medical advice.
-

Transporting the printer

If you need to transport the printer over a long distance, consult your service representative.

Care of printer supplies

Use the following precautions when handling the printer supplies (toner, paper, etc.).

- ✦ Store the supplies in a location that meets the following requirements:
 - free from direct sunlight
 - away from any heating apparatus
 - not subjected to high humidity
 - not extremely dusty
- ✦ Store in a sealed plastic bag in a cool, dark place paper that has been removed from its wrapper but not loaded into the printer.
- Only use toner that has been manufactured specifically for this printer. Never use other types of toner.
- Keep all supplies out of the reach of children.



CAUTION**Precautions for handling toner:**

- Be careful not to spill toner inside the printer or get toner on your clothes or hands.
 - If your hands become soiled with toner, immediately wash them with soap and water.
 - If toner gets in your eyes, immediately flush them with water, and then seek professional medical advice.
-

3 Before Making Prints

3.1 Components and Their Functions

The following describes each of the units that the printer is composed of as well as their functions.

- **Printer**
Prints out the image received from the computer

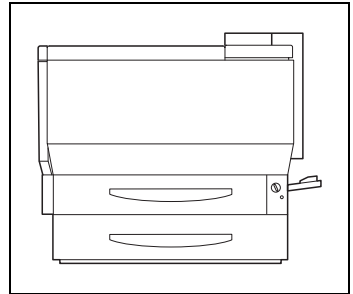

- **10-Mailbin sorter JS-1002 (optional)**
Feeds pages into the mailbin specified at the computer

Note)

If Fiery X3e has been installed, the 10-mailbin sorter is not operational.

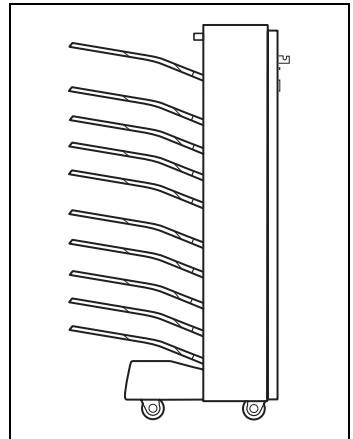

- Finisher FN-107/FN-108 (optional) finishes pages according to the mode (electronic sorting, stapling or hole-punching) selected at the computer, then feeds out the pages

Note)

If MicroPress PrintLink 2020m is installed, only FN107 is supported.

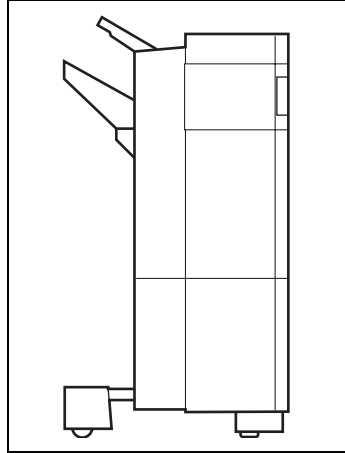

- Duplex unit AD-14 (optional) Automatically turns over prints, allowing double-sided prints to be made

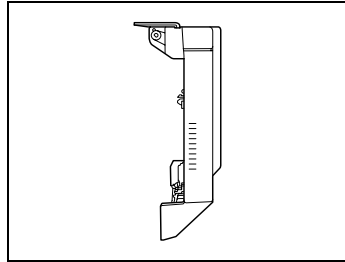

- Paper feed unit PF-118 (optional) Can supply 500 sheets of paper; up to two paper feed units can be installed

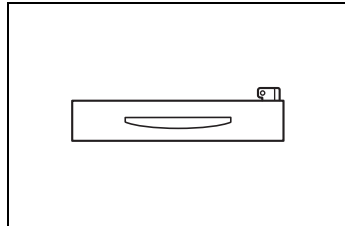

- Large-capacity cabinet PF-117 (optional) Can supply 2,500 sheets of paper

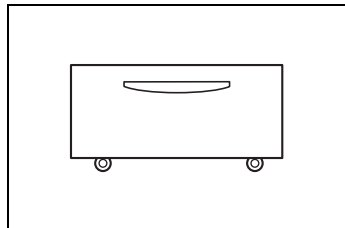

- Copy desk (optional)
Used when the optional 10-mailbin sorter (JS-1002) or an optional finisher (FN-107/FN-108) is installed without an optional paper feed unit

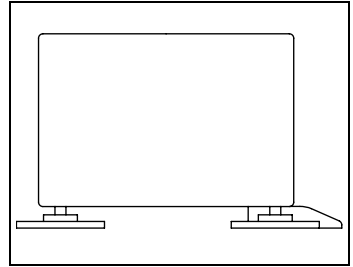

- Copy table (optional)
Used when the optional 10-mailbin sorter (JS-1002) or an optional finisher (FN-107/FN-108) is installed with two optional paper feed units installed

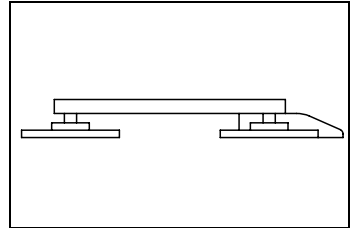

- Printer controller Fiery X3e
Internal printer controller that allows the printer to be used as a color printer on a network
- Printer controller MicroPress PrintLink 2020m
Internal printer controller that allows the printer to be used as a color printer on a network

3.2 Parts Names and Their Functions

Outside of Printer

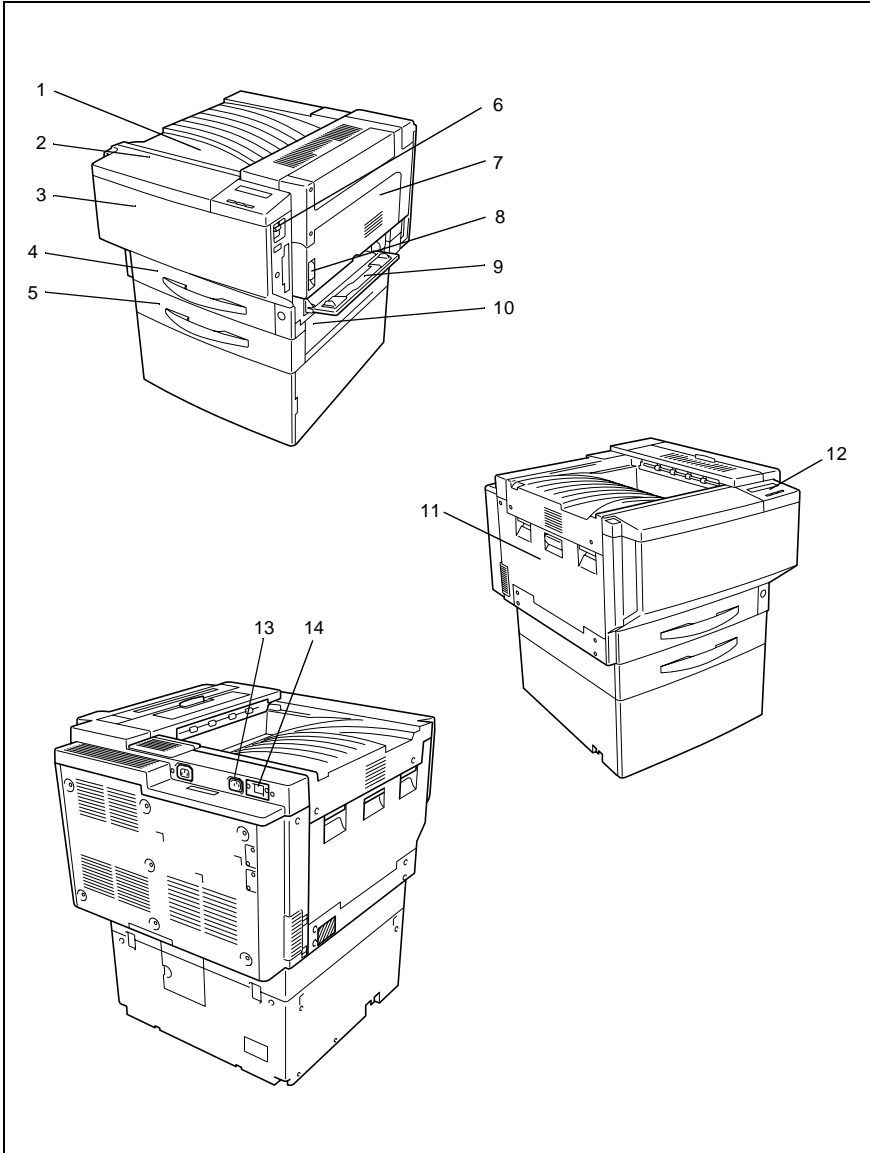

* The copy desk shown installed in the illustration is optional.

No.	Part Name	Description
1	Print output tray	Holds printouts fed from the printer
2	Toner supply door	Opened when adding toner
3	Front door	Opened when servicing the printer.
4	Tray 1	Holds 250 sheets of paper The paper size can be adjusted freely. Special paper can be used. See p. 4-7.
5	Tray 2	Holds 500 sheets of paper The paper size can be adjusted freely. See p. 4-12.
6	Power switch	Used to turn the printer on and off See p. 3-14.
7	Right-side door	Opened when servicing the printer and clearing misfeeds
8	Right-side door release lever	Used to open and close the right-side door
9	Manual bypass tray*	Used for manual feeding of paper The paper is fed one sheet at a time
10	Lower right-side door	Opened when clearing misfeeds
11	Left-side door	Opened when servicing the printer
12	Control panel	Displays the current status of the printer
13	Printer power cord socket	Used for connecting the printer's power cord
14	Sorter/finisher connector	Used for connecting the sorter or finisher hookup cord

* When Fiery X3e is installed, printing from the manual bypass tray is not supported.

Inside of Printer

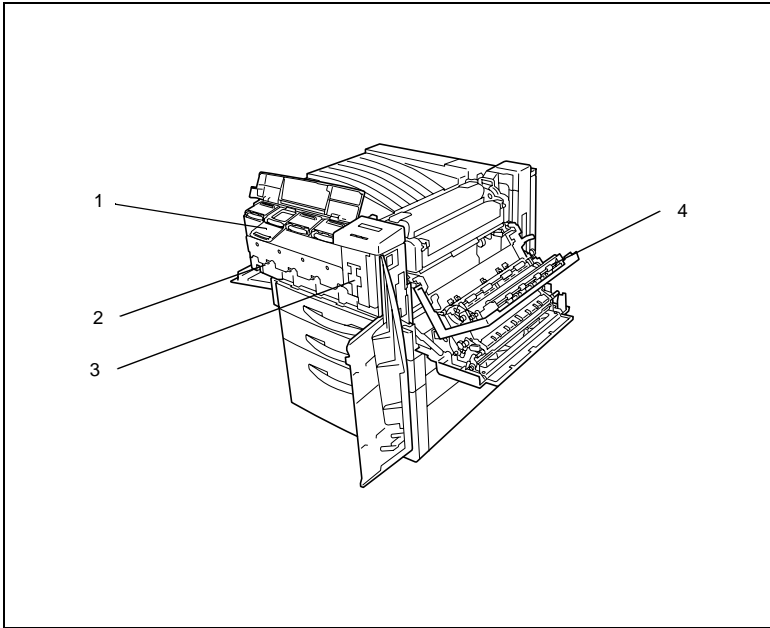

No.	Part Name	Description
1	Toner hopper lid	Opened when adding toner
2	Imaging unit release lever	Used to install and replace the imaging unit
3	Imaging unit removing bracket	Used to remove the imaging unit
4	Upper right-side door	Opened when replacing the fusing unit or clearing misfeeds

Supplies and Parts

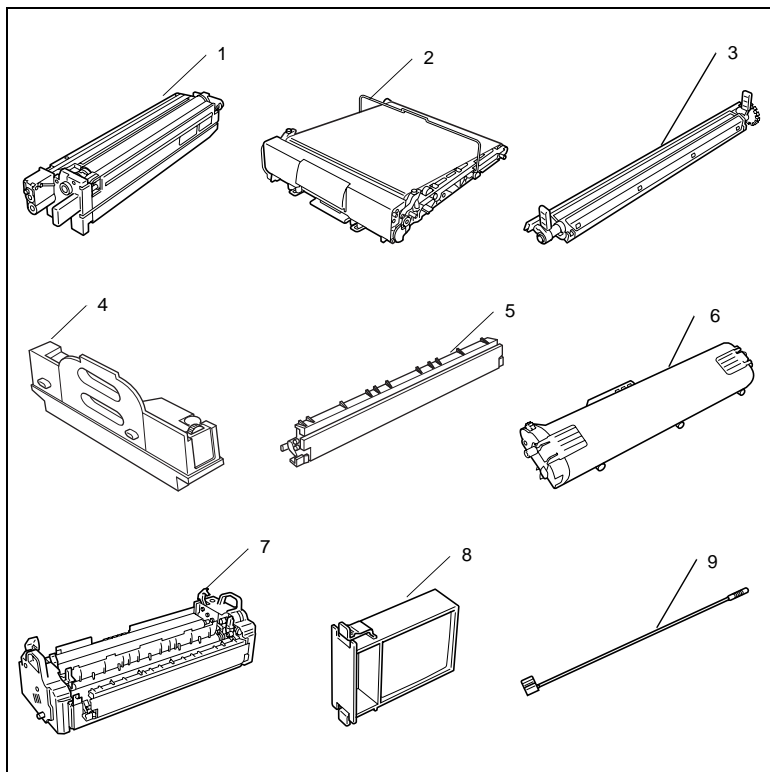

No.	Part Name	Description
1	Imaging unit	Generates the printed image
2	Image transfer belt unit	Lays onto the image transfer belt each of the single colors of the image generated by the imaging unit in order to create a full-color image
3	Image transfer roller unit	Transfers onto the paper a full-color image generated by the image transfer belt unit
4	Waste toner bottle	Collects waste toner
5	Oil-coating unit	Supplies oil to the fusing roller
6	Fusing web unit	Supplies oil to the fusing belt
7	Fusing unit	Fuses the transferred toner to the paper
8	Ozone filter	Collects the ozone generated in the printer
9	LED cleaning tool	Used to clean the surface of the LED unit, for example when replacing the imaging unit Store in a safe place for later use.

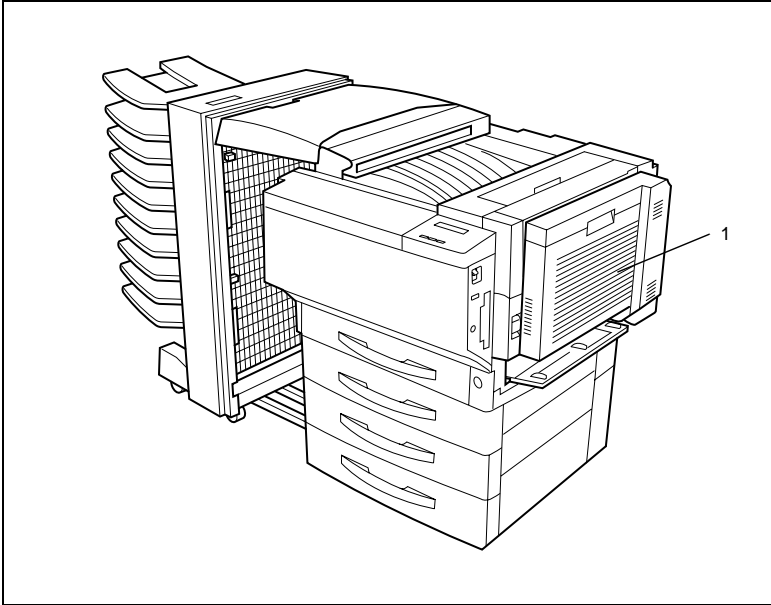
Duplex Unit (Optional)

No.	Part Name	Description
1	Duplex unit door	Opened when clearing paper misfed within the duplex unit

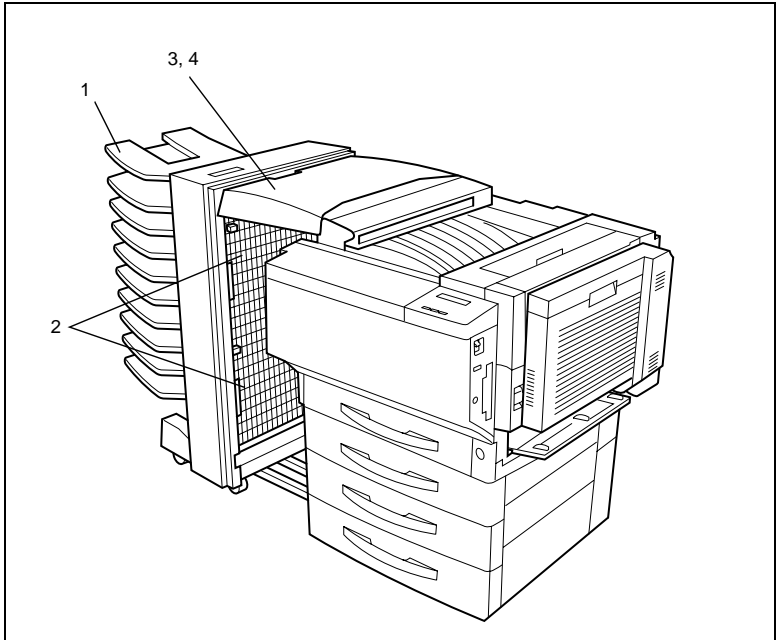
10-Mailbin Sorter (Optional)

No.	Part Name	Description
1	Mailbins	Paper is fed to the mailbin specified with the printer driver
2	Upper door/Lower door	Opened when clearing paper misfed within the sorter
3	Horizontal transport unit cover	Transports prints to the sorter or finisher
4	Horizontal transport unit	Opened when clearing paper misfed within the horizontal transport unit

Finisher (Optional)

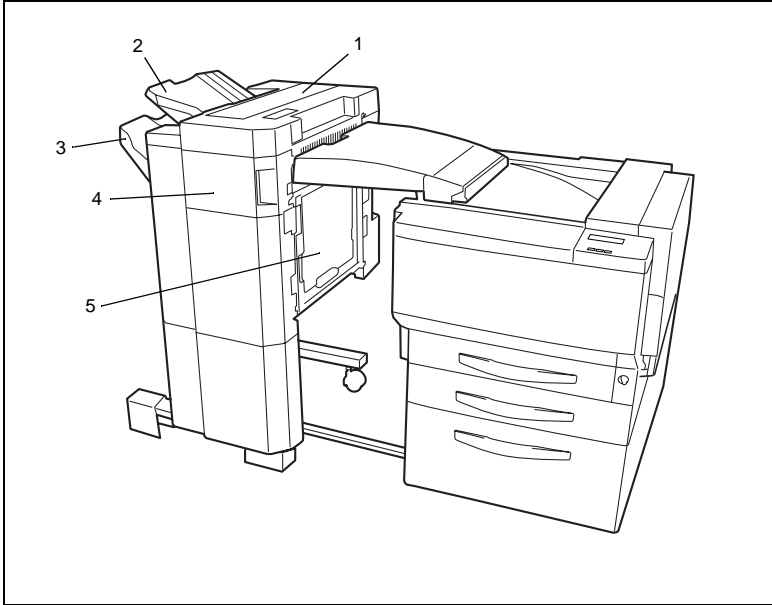

No.	Part Name	Description
1	Upper cover	Opened when clearing paper misfed within the finisher
2	Upper paper output tray	Collects printouts on special paper. (overhead projector transparencies, thick paper 1, thick paper 2, and postcards)
3	Lower paper output tray	Collects printouts on normal paper.
4	Front door	Opened when clearing paper misfed within the finisher
5	Right-side door (Finisher FN-107 only)	Opened when replacing the staple cartridge or clearing paper misfeeds

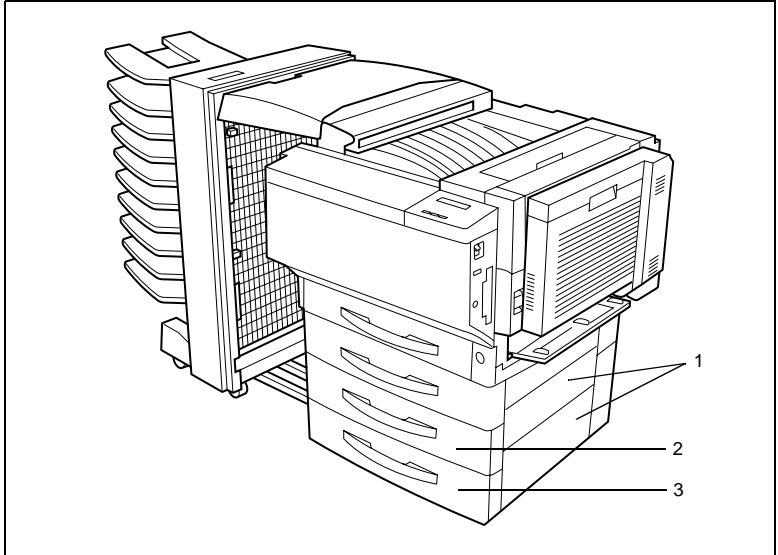
Paper Feed Unit (Optional)

No.	Part Name	Description
1	Side door	Opened when clearing paper misfeeds
2	Tray 3	Holds 500 sheets of paper The paper size can be adjusted freely.
3	Tray 4	As many as two units can be installed. See p. 4-12.

Large-Capacity Cabinet (Optional)

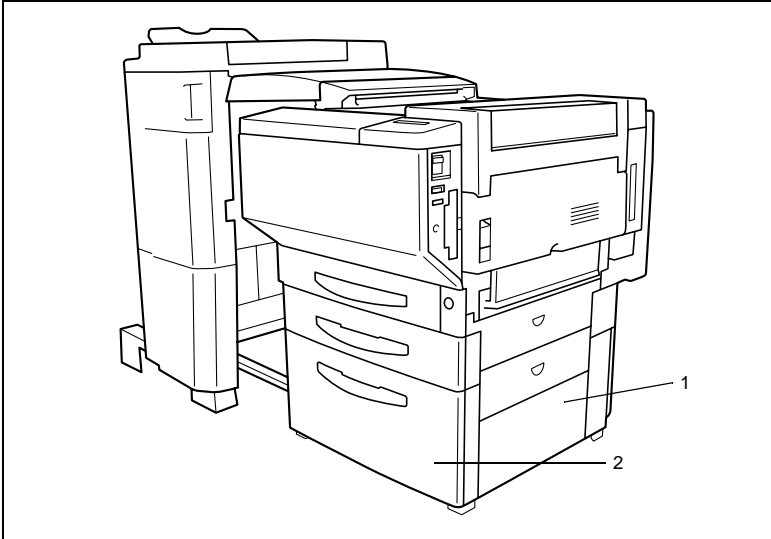

No.	Part Name	Description
1	Side door	Opened when clearing paper misfeeds
2	Large-Capacity Cabinet	Holds 2,500 sheets of paper See p. 4-14.

Printer Controller Fiery X3e

For more details, refer to the manual of the printer controller.

Printer Controller MicroPress PrintLink 2020m

For more details, refer to the manual of the printer controller.

3.3 Names of Control Panel Parts and Their Functions

Names of Control Panel Parts and Their Functions

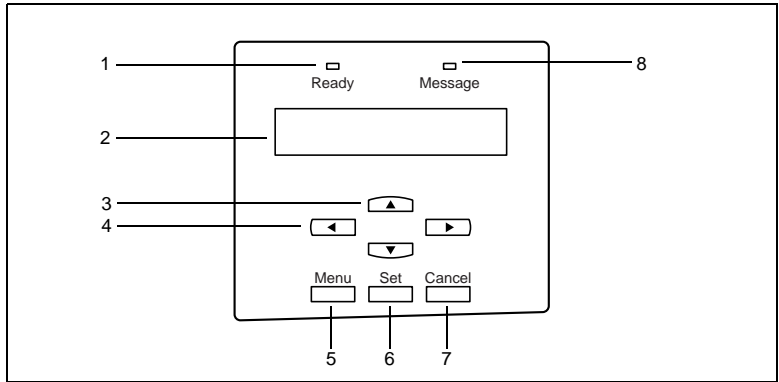

No.	Part Name	Description
1	Ready light	<ul style="list-style-type: none"> Off when the Fiery X3e is off or starting up Lights up in green to indicate the normal operating condition Flashes green when the Fiery X3e is proceeding to RIP or printing a job, or communicating with a remote computer. (for example, through the Fiery Spooler)
2	Display window	<ul style="list-style-type: none"> Displays information about the current status
3	Up/down buttons	<ul style="list-style-type: none"> Up button: Returns to the previous option or setting if pressed when a menu is displayed; displays the previous character if pressed when entering text Down button: Advances to the next option or setting if pressed when a menu is displayed; displays the next character if pressed when entering text
4	Right/left buttons	<ul style="list-style-type: none"> Right arrow: Advances the cursor to the next entry position on the right Left arrow: Deletes the character to the left if pressed when entering text
5	Menu button	<ul style="list-style-type: none"> Displays the Functions menu; returns to the menu if pressed after an option has been selected
6	Set button	<ul style="list-style-type: none"> Activates the currently selected option and, if applicable, proceeds to the next menu
7	Cancel button	<ul style="list-style-type: none"> Exits the setup and returns to Info; stops printing or processing the current job if pressed when printing
8	Message light	<ul style="list-style-type: none"> Lights up in red for more than 30 seconds to indicate a communication error between the Fiery X3e and the printer Flashes red if there is an error that prevents printing

3.4 Power Switch

Turning the printer on and off

To turn the printer on

→ Set the power switch to “I”.

To turn the printer off

→ Set the power switch to “O”.

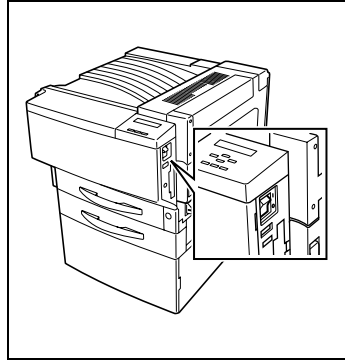

Note

Do not turn off the printer while it is printing, otherwise a paper misfeed may occur. Make sure that all print operations are finished before turning off the printer.



Note

With Fiery X3e installed, if the printer is turned off directly, instead of turning off the system using the control panel, the controller may be damaged.



Note

If the printer is not used for 15 minutes, it automatically enters Energy Saver mode.

The printer will automatically start warming up as soon as it receives a print job, or when any cover is opened, then closed.

Turning On the Printer

After the printer is turned on, the controller is initialized. After the controller has finished warming up, the Ready light lights up in green and “Info XXXX” appears in the display.

However, a print operation is not performed until the printer has finished warming up (after about 5 minutes at normal room temperature (68 °F/20 °C)).

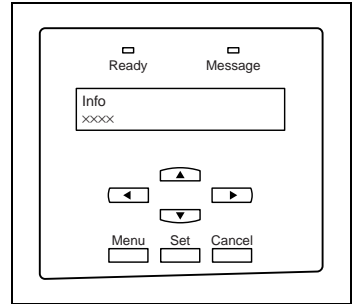

Note

“XXXX” indicates the name specified when the controller was set up. (For more details, refer to the manual of the printer controller.)

Turning Off the Printer



Note

If Fiery X3e is installed, be sure to shut down the controller system before turning off the printer.

If MicroPress PrintLink 2020m is installed, turn off the printer by performing just step 5.

To turn off the printer

- 1 Check that “Info XXXX” appears in the display, and then press the [Menu] button in the control panel.

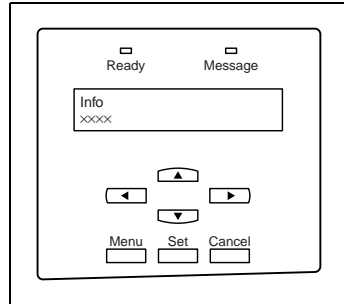

- 2 Press ▲ or ▼ until “Functions Shut Down” appears, and then press the [Set] button.

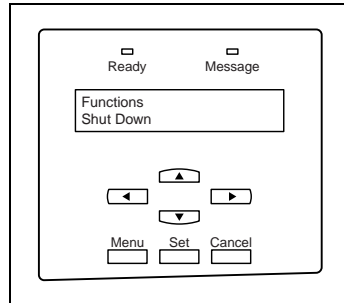

- 3 Press ▼ once to display “Shut Down Shut Down System”, and then press the [Set] button to begin shutting down the system.

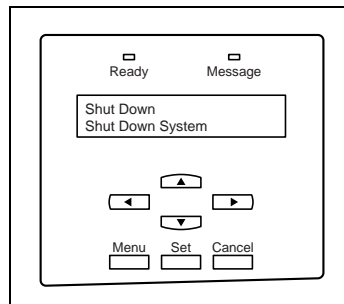

- 4 When the system has finished shutting down, “Safe to power off the system” appears.

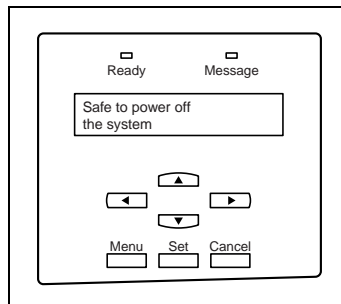

- 5 Set the power switch to “O”.

3.5 Total Counter

The total counter can be printed out by following the procedure below.

To print the total counter

- 1 Check that “Info XXXX” appears in the display, and then press the [Menu] button in the control panel.

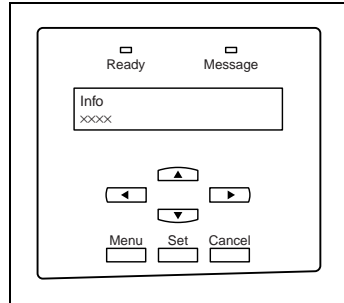

- 2 Press ▲ or ▼ until “Function Print Pages” appears, and then press the [Set] button.

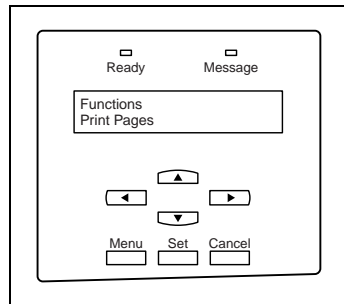

- 3 Press ▲ or ▼ until “Functions Total Counter” appears, and then press the [Set] button.

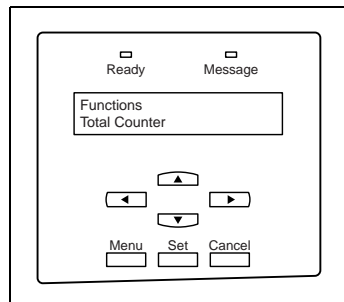

- 4 The total counter is printed out. (Refer to page 4-7 for Loading Paper.)

2001 6 26 16 29			
Serial #			
Total Check			
	Full Color	Black	Dup. Copy
Copy	0	0	0
Large	0	0	
Print	71	10	Dup. Print
Large	0	0	0
G.Total	81		

4 Print Paper

4.1 Paper Specifications

Use paper that meets the following specifications.

Paper Types

Paper Types	Standard Paper	Special Paper			
		Thick Paper1	Thick Paper2	Overhead Projector Transparencies	Postcards
Weight (lbs.)	17.02 lbs. to 23.94 lbs.	24. 21 lbs. to 43.36 lbs.	43.62 lbs. to 55.59 lbs.		
Weight (g/m ²)	(64 g/m ² to 90 g/m ²)	(91 g/m ² to 163 g/m ²)	(164 g/m ² to 209 g/m ²)		
Tray 1	<input type="radio"/>	<input type="radio"/>	—	<input type="radio"/>	<input type="radio"/>
Tray 2	<input type="radio"/>	—	—	—	—
Manual bypass tray ^{*1}	<input type="radio"/>	<input type="radio"/>	<input type="radio"/>	<input type="radio"/>	<input type="radio"/>
Paper Feed Unit ²	<input type="radio"/>	—	—	—	—
Large-Capacity Cabinet ²	<input type="radio"/>	—	—	—	—

* 1: When Fiery X3e is installed, printing from the manual bypass tray is not supported.

2: The paper feed unit and large-capacity cabinet are optional.

Paper Sizes

Standard paper:

Paper Size	12.25 x 18L ^{*3}	11 x 17 L	11 x 14 L	LegalL	LetterL	LetterC	Execu-tiveL
Paper Source							
Tray 1	○	○	○	○	○	○	○
Tray 2	—	○	○	○	○	○	—
Manual bypass tray ^{*1}	○	○	○	○	○	○	○
Paper Feed Unit ^{*2}	—	○	○	○	○	○	—
Large-Capacity Cabinet ^{*2}	—	—	—	—	—	○	—

Paper Size	Execu-tiveC	5.5 x 8.5L	5.5 x 8.5C	4 x 6L ^{*3}	A3Wide L ^{*4}	A3L	A4L
Paper Source							
Tray 1	○	○	○	○	○	○	○
Tray 2	—	—	—	—	—	○	○
Manual bypass tray ^{*1}	○	○	○	○	○	○	○
Paper Feed Unit ^{*2}	—	—	—	—	—	○	○
Large-Capacity Cabinet ^{*2}	—	—	—	—	—	—	—

Paper Size Paper Source, Etc.	A4C	A5L	A5C	A6L^{*4}
Tray 1	○	○	○	○
Tray 2	○	—	—	—
Manual bypass tray ^{*1}	○	○	○	○
Paper Feed Unit ^{*2}	○	—	—	—
Large-Capacity Cabinet ^{*2}	○	—	—	—

- * 1: When Fiery X3e is installed, printing from the manual bypass tray is not supported.
2: The paper feed unit and large-capacity cabinet are optional.
3: For North America only
4: For Europe only

Paper capacity:

Paper Type Paper Source, Etc.	Standard Paper	Special Paper			
		Thick Paper1	Thick Paper2	Overhead Projector Transpar- encies	Postcards
Tray 1	250 sheets	20 sheets	—	20 sheets	20 sheets
Tray 2	500 sheets	—	—	—	—
Manual bypass tray ^{*1}	1 sheet	1 sheet	1 sheet	1 sheet	1 sheet
Paper Feed Unit ^{*2}	500 sheets	—	—	—	—
Large-Capacity Cabinet ^{*2}	2,500 sheets	—	—	—	—

- * 1: When Fiery X3e is installed, printing from the manual bypass tray is not supported.
 2: The paper feed unit and large-capacity cabinet are optional.

Recommended paper:

Paper Type		Recommended Paper
Standard Paper	For full-color prints	CF80 Hammermill Laser Print New Radiant White ^{*1} Color Copy 90 ^{*2}
	For black-and-white prints	MINOLTA bond ^{*1} MINOLTA bond IV ^{*1} Original ^{*2}
Thick Paper 1		CF105 NS 700
Thick Paper 2		NS 1000C
Overhead Pro- jector Transpar- encies	For full-color prints	CF-300D
	For black-and-white prints	M-100D

- * 1: The paper is available for North America only.
 2: The paper is available for Europe only.

Paper Types To Be Avoided

The following types of paper should not be used, otherwise decreased print quality, paper misfeeds or damage to the printer may occur.

- Overhead transparencies that have already been fed through the printer (even if the transparency is still blank)
- Paper that has been printed on by a heat-transfer printer or an inkjet printer
- Paper that is either extremely thick or extremely thin
- Folded, rolled, wrinkled, or torn paper
- Perforated paper or paper with holes punched in it
- Extremely smooth or extremely rough paper, or paper with an uneven surface
- Paper that has been treated, such as carbon-backed paper, or heat-sensitive or pressure-sensitive paper
- Paper that has been decorated with foil or embossing
- Paper of various sizes
- Paper of a non-standard shape (not rectangular)
- Paper that is bound with glue, staples, or clips
- Paper with labels attached
- Paper with ribbons, hooks, buttons, etc. attached

4.2 Print Area

When using a printer controller to print from a computer, any part of the original image within the areas indicated below is not printed.

The sizes of the paper margins differ according to the controller that is used.

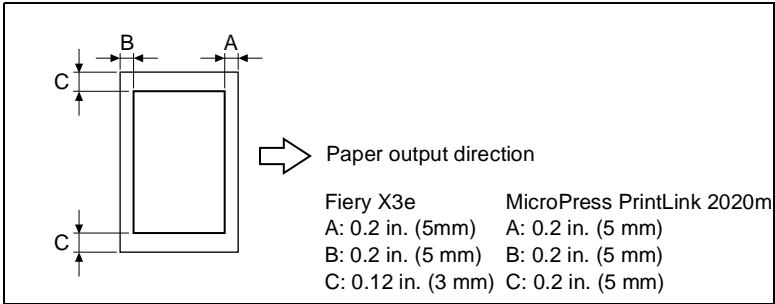

4.3 Paper Storage

Observe the following precautions when storing the paper.

- + Store the paper in a location that meets the following requirements.
 - Not exposed to direct sunlight
 - Not exposed to fire
 - Not exposed to high humidity
 - Not extremely dusty
- + Unwrapped paper should be stored in a plastic bag in a cool, dry location.
- Keep paper out of the reach of children.

4.4 Loading Paper

To load paper into Tray 1 (250-sheet multipurpose tray)

- 1 Pull out the paper drawer for Tray 1.

? *Has the paper take-up roller been touched?*

- Be careful not to touch the surface of the paper take-up roller with your hands. If the roller has been touched, wipe it with a dry cloth.

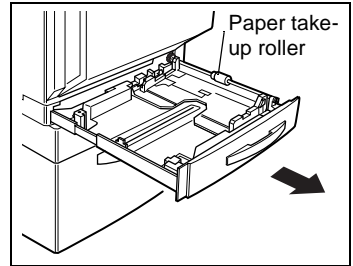

- 2 Press down on the paper-lifting plate until it locks into place.

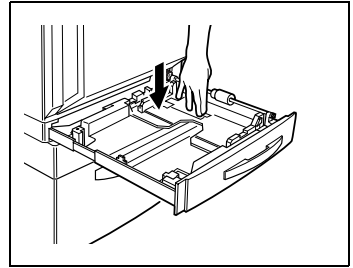

- 3 Slide the lateral guides to fit the size of paper to be loaded.

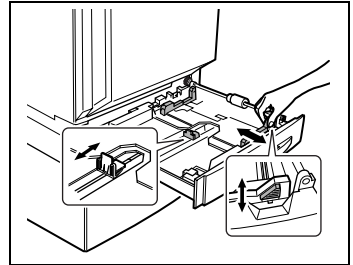

- For “12-1/4 × 18” or A3Wide paper, adjust the trailing-edge guides as shown in the illustration.

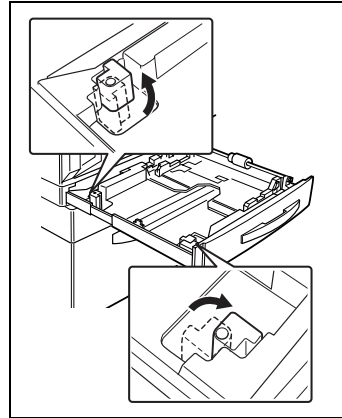

- 4 Load the paper into the drawer so that the front side of the paper (the side facing up when the package was unwrapped) faces up.

? *Has the paper been loaded correctly?*

If the paper is not loaded correctly, a paper misfeed may occur.

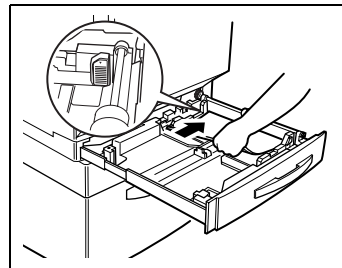

- Do not load so much paper that the top of the stack is higher than the ▼ mark.
- Do not load more than 20 sheets of thick paper 1, overhead projector transparencies, or postcards.
- When loading additional paper, remove any paper remaining in the drawer, place it on the new paper, and then align the paper in the stack well before loading it into the drawer.
- We recommend replenishing the paper only after all of the paper in the drawer has been used.

? *Are postcards loaded?*

→ When loading postcards, load them as shown.

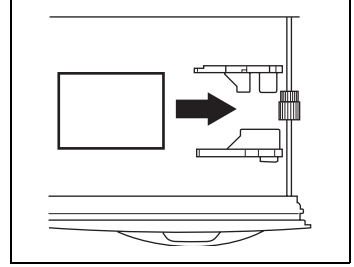

→ Do not load postcards cross-wise, as shown.

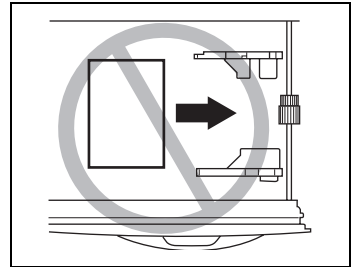

? *Are the recommended overhead projector transparencies (MINOLTA CF300D) loaded?*

→ When loading the recommended overhead projector transparencies (MINOLTA CF300D), load them as shown in the illustration.

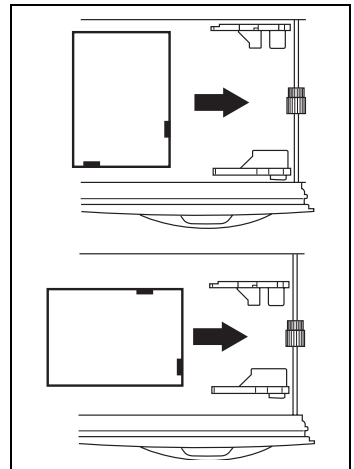

- 5 Slide the lateral guides against the edges of the paper.

- Make sure that the paper is not curled when it is loaded. Check that the lateral guides are pushed up against the edges of the paper.

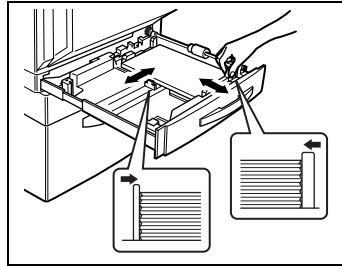

- 6 Close the paper drawer.

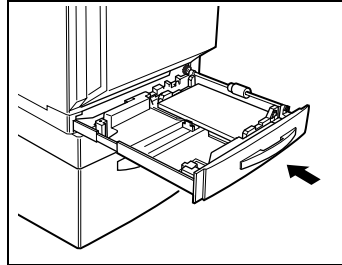

- 7 Turn the media type selection dial on the drawer to the setting for the type of paper loaded.

? *Are postcards loaded into Tray 1?*

- If postcards (4 × 6 or A6) are loaded, the paper type setting cannot be selected using the media type selection dial on the drawer. Instead, use the control panel buttons to select the paper size setting for postcards (4 × 6 or A6).

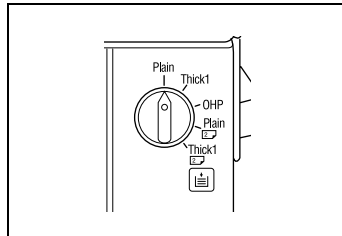

To set the paper size for Tray 1

- 1 Check that “Info XXXX” appears in the display, and then press the [Menu] button in the control panel.

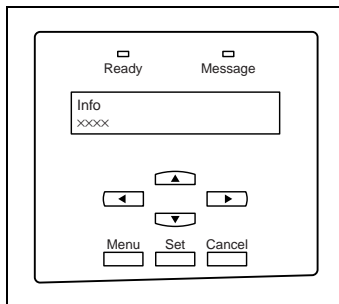

- 2 Press ▲ or ▼ until “Engine Setup” appears, and then press the [Set] button.

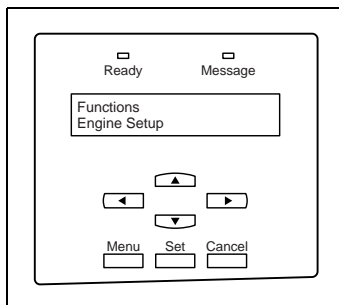

- 3 Press ▲ or ▼ until the desired paper size appears, and then press the [Set] button.

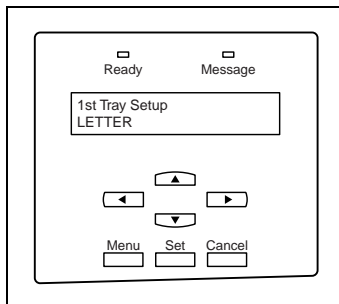

- 4 Press the [Cancel] button.

To load paper into Tray 2 or the 500-sheet paper feed unit

- 1 Pull out the paper drawer.

? *Has the paper take-up roller been touched?*

- Be careful not to touch the surface of the paper take-up roller with your hands. If the roller has been touched, wipe it with a dry cloth.

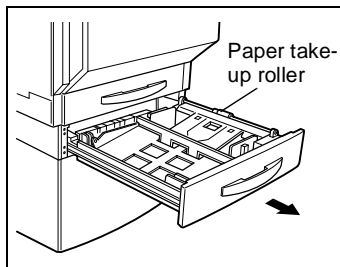

- 2 Press down on the paper-lifting plate until it locks into place.

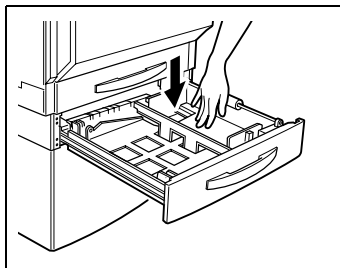

- 3 Remove the trailing-edge guide, and then re-install it for the size of paper to be loaded.

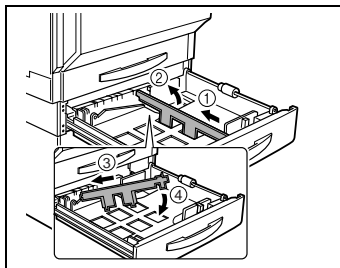

- 4 Slide the lateral guides to fit the size of paper to be loaded.

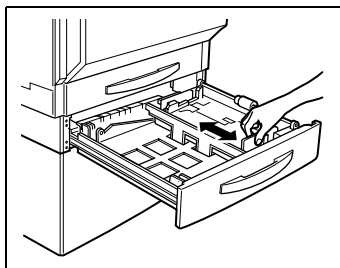

- 5 Load the paper into the drawer so that the front side of the paper (the side facing up when the package was unwrapped) faces up.

? *Has the paper been loaded correctly?*

If the paper is not loaded correctly, a paper misfeed may occur.

- Do not load so much paper that the top of the stack is higher than the ▼mark.
- Special paper cannot be fed from Tray 2 or optional paper feed units. If you wish to make prints onto special paper, feed it through Tray 1.
- When loading additional paper, remove any paper remaining in the drawer, place it on the new paper, and then align the paper in the stack well before loading it into the drawer.
- We recommend replenishing the paper only after all of the paper in the drawer has been used.

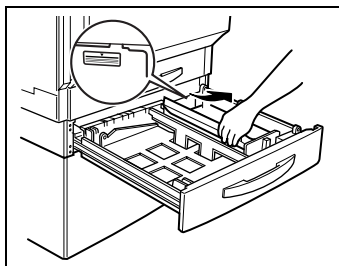

- 6 Slide the lateral guides against the edges of the paper.

- Make sure that the paper is not curled when it is loaded. Check that the lateral guides are pushed up against the edges of the paper.

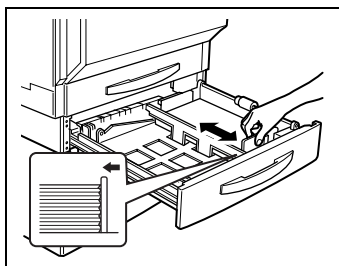

- 7 Close the paper drawer.

To load paper into the large-capacity cabinet

- 1 Pull out the paper drawer.

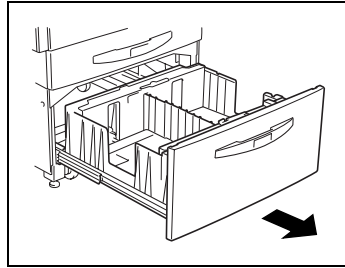

- 2 Load paper into the right side of the drawer so that the front side of the paper (the side facing up when the package was unwrapped) faces up.

? *Has the paper been loaded correctly?*

If the paper is not loaded correctly, a paper misfeed may occur.

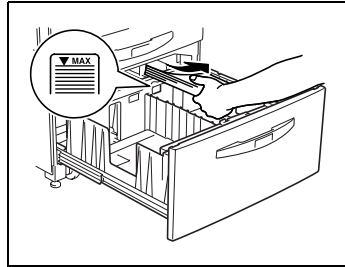

- Make sure that the paper is not curled when it is loaded.
- Do not load so much paper that the top of the stack is higher than the ▼mark.
- Special paper cannot be fed from Tray 2 or optional paper feed units. If you wish to make prints onto special paper, feed it through Tray 1.
- When loading additional paper, remove any paper remaining in the drawer, place it on the new paper, and then align the paper in the stack well before loading it into the drawer.
- We recommend replenishing the paper only after all of the paper in the drawer has been used.

- 3 Load paper into the left side of the drawer so that the front side of the paper (the side facing up when the package was unwrapped) faces up.

? *Has the paper been loaded correctly?*

If the paper is not loaded correctly, a paper misfeed may occur.

- Make sure that the paper is not curled when it is loaded.
- Do not load so much paper that the top of the stack is higher than the ▼mark.
- Special paper cannot be fed from Tray 2 or optional paper feed units. If you wish to make prints onto special paper, feed it through Tray 1.
- When loading additional paper, remove any paper remaining in the drawer, place it on the new paper, and then align the paper in the stack well before loading it into the drawer.
- We recommend replenishing the paper only after all of the paper in the drawer has been used.

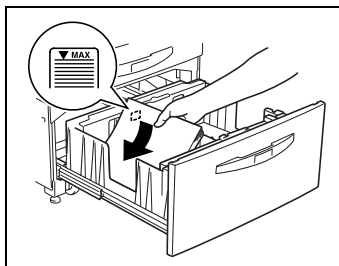

- 4 Close the paper drawer.

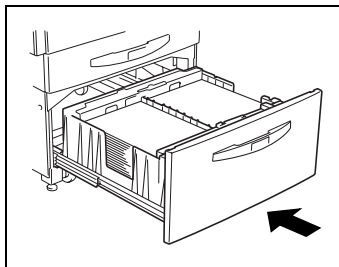

To load paper into the manual bypass tray

Paper can be fed manually through the manual bypass tray if you wish to print onto paper that is not loaded into a drawer or if you wish to print onto special paper, such as overhead transparencies, postcards, or thick paper 1 or 2.

Note

- ✓ When Fiery X3e is installed, printing from the manual bypass tray is not supported.

- 1 Open the manual bypass tray.

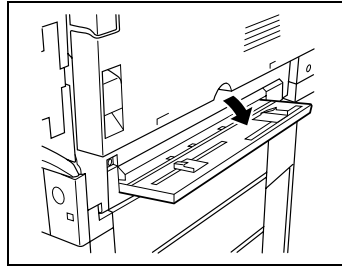

- 2 Adjust the paper guides to the size of the paper, and then load the paper so that the front side of the paper (the side facing up when the package was unwrapped) faces down. Lightly slide the paper into the feed slot as much as possible so that it is ready to be fed into the printer.

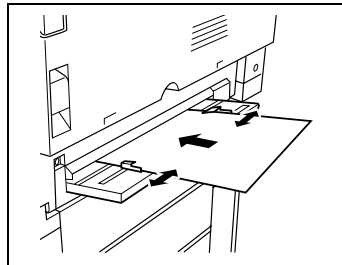

? *Do you need more information on feeding paper through the manual bypass tray?*

- Feed only one sheet of paper at a time.
- Prints will be made on the surface of the paper facing down when it is loaded into the manual bypass tray.

? *Is a postcard loaded?*

- When loading a postcard, load it as shown.

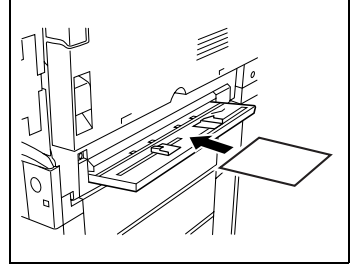

- Do not load the postcard cross-wise, as shown.

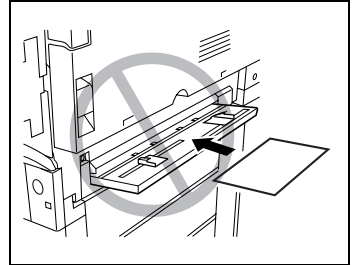

? *Is the recommended overhead projector transparency (MINOLTA CF300D) loaded?*

- When loading the recommended overhead projector transparency (MINOLTA CF300D), load it as shown in the illustration.

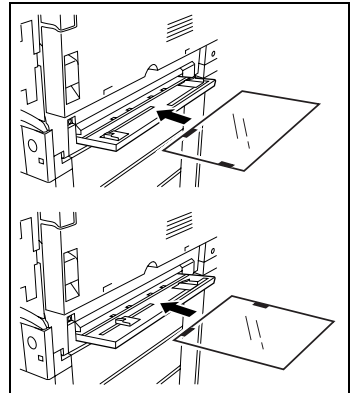

5 Control Panel Messages

5.1 Message List

When a message appears in the control panel display, refer to the section for details about the message and the action to be taken.



Note

The display window only displays two lines of a message at one time. To view messages longer than two lines, press ▼ to display the next line of the message.

Message	Cause	Action
Busy	The printer is printing.	Wait for a while.
Check power of DT105	Power is not being supplied to the DT105.	Check that power is supplied to the DT105.
Cover open at xx	The indicated cover is open.	Press ▼ once, check which cover is open, and then close it. <ul style="list-style-type: none"> • Front p. 3-5, #3 • Right Side p. 3-5, #7 • Left Side p. 3-5, #11 • Fusing Unit p. 3-6, #4 • 2nd Feed p. 3-5, #10 • 3rd Feed p. 3-11, #1 • 4th Feed p. 3-11, #1 • LCC Feed p. 3-12, #1 • Duplex p. 3-8, #1 • Horizontal Transport p. 3-9, #4 • Finisher Front p. 3-10, #4 • Finisher Upper p. 3-10, #1 • Sorter Correctly attach the sorter to the printer. <ul style="list-style-type: none"> • Finisher Correctly attach the finisher to the printer.
Image Stabilizing	The printer is now image stabilizing.	No action required.
Load xx in xx	Paper of size xx and type xx is not loaded in the specified tray.	Load paper of size xx and type xx into the specified tray.
Load xx in xx	Xx-size paper is not loaded into the specified tray.	Load xx-size paper into the specified tray.

Message	Cause	Action
Load xx OHP in tray1	Xx-size overhead projector transparencies is not loaded into tray 1.	Load xx-size overhead projector transparencies into tray 1.
Load xx in any tray	Xx-size paper has not been loaded into any tray.	Load xx-size paper into any tray.
Load xx Thick 1 in tray1	Xx-size thick 1 is not loaded into tray 1.	Load xx-size thick 1 into tray 1.
Near trouble ## / ##	Some malfunction occurred in the printer.	Contact your technical representative and inform them of the error code.
No back staples	The back staples have run out.	Install new back staples.
No front staples	The front staples have run out.	Install new front staples.
No xxxx toner Call service	The toner for the indicated color is empty.	Ask your technical representative to refill the toner for the indicated color.
No xxxx toner Please change	The toner for the indicated color is empty.	Refill the toner for the indicated color.
Paper jam at Jx	A paper jam or staple jam occurred at the indicated location.	Remove the jammed paper or the jammed staple. See page 5-16
Power save mode	The printer has entered Energy Saver mode.	<ul style="list-style-type: none"> • To cancel Energy Saver mode, send a print job, or open and close a cover. • To change the time for the printer to enter Energy Saver mode, contact a technical representative.
Printing stopped	Paper is loaded into the manual bypass tray.	Remove all paper from the manual bypass tray.
	A communication error occurred.	No action required
Printing suspended	Printing has been stopped.	No action required.
Replace Trans. Belt Unit	The service life of the transfer belt unit has expired.	Replace the transfer belt unit.
Service Code Cxxxx	An error occurred.	Contact your technical representative and inform them of the error code.
Sleep mode	The printer has entered Sleep mode.	<ul style="list-style-type: none"> • To cancel Sleep mode, send a print job, or open and close a cover. • To change the time for the printer to enter Sleep mode, contact a technical representative.
The guides in tray # not set right	The size of the paper loaded into tray # is incorrect.	Load paper of an appropriate size into tray #.

Message	Cause	Action
To print, clear 1st tray	The upper paper output tray of the finisher is full of paper.	Remove paper from the upper paper output tray.
To print, clear elevator tray	The lower paper output tray of the finisher is full of paper.	Remove paper from the lower paper output tray.
To print, clear mail bin #	The mail bin # of the 10-mailbin sorter is full of paper.	Remove paper from the mail bin #.
To print, clear sorter area	All bins in the 10-mailbin sorter are full of paper.	Remove all paper from the mailbins.
Warming up	Warming up	No action required.
Waste toner full. Call service	The waste toner bottle is full.	Ask your technical representative to refill the toner for the indicated color.
Waste toner full. Please change	The waste toner bottle is full.	Replace the waste toner bottle.
Waste toner nearly full	The waste toner bottle will soon be full.	Replace the waste toner bottle as soon as possible.
Waste toner bottle not set	The waste toner bottle is not installed.	Install the waste toner bottle.
Xxxx toner nearly empty	The toner for the indicated color will soon be empty.	Refill the toner for the indicated color.
Xxxx unit near life limit	The indicated unit will soon reach the end of its service life.	Replace the indicated unit.
Xxxx unit not set	The indicated unit is not installed.	Install the indicated unit.
Xxxx unit not set right	The indicated unit is not installed correctly.	Install the indicated unit correctly or contact your technical representative.
Xxxx unit over life limit Call service	The service life for the indicated unit has expired.	Ask your technical representative to replace the indicated unit.
Xxxx unit over life limit Please change	The service life for the indicated unit has expired.	Replace the indicated unit.

To load paper into Tray 1 (250-sheet multipurpose paper drawer)

- 1 Pull out the paper drawer.

? *Has the paper take-up roller been touched?*

- Be careful not to touch the surface of the paper take-up roller with your hands. If the roller has been touched, wipe it with a dry cloth.

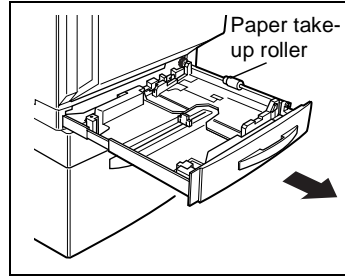

- 2 Press down on the paper-lifting plate until it locks into place.

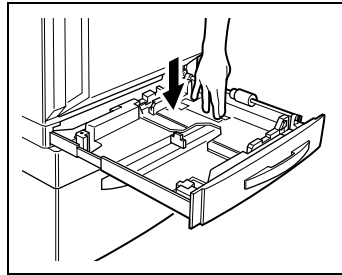

- 3 Load the paper into the drawer so that the front side of the paper (the side facing up when the package was unwrapped) faces up.

? *Have you loaded too much paper into the drawer?*

- Do not load so much paper that the top of the stack is higher than the ▼ mark.

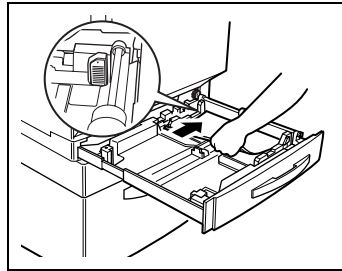

? *Has the paper been loaded correctly?*

- Make sure to align the stack of paper.

? *Do you wish to load a paper size or type different from that previously loaded?*

- For more details on changing the paper size and type, refer to "Loading Paper" on page 4-7.

- 4 Slide the lateral guides against the edges of the paper.
 - Make sure that the paper is not curled when it is loaded. Check that the lateral guides are pushed up against the edges of the paper.

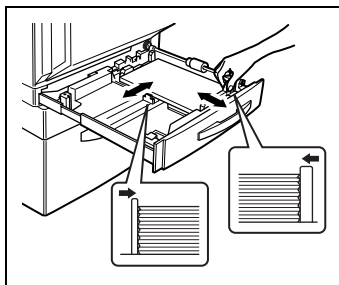

- 5 Close the paper drawer.

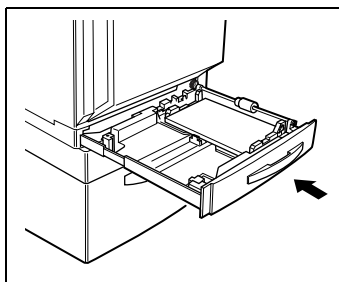

To load paper into Tray 2 or the 500-sheet paper feed unit

- 1 Pull out the paper drawer.
 - ? *Has the paper take-up roller been touched?*
 - Be careful not to touch the surface of the paper take-up roller with your hands. If the roller has been touched, wipe it with a dry cloth.

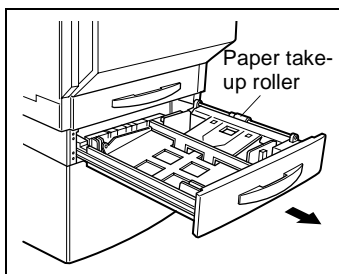

- 2 Press down on the paper-lifting plate until it locks into place.

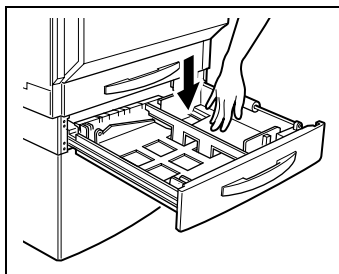

- 3 Load the paper into the drawer so that the front side of the paper (the side facing up when the package was unwrapped) faces up.

? *Have you loaded too much paper into the drawer?*

- Do not load so much paper that the top of the stack is higher than the ▼ mark.

? *Has the paper been loaded correctly?*

- Make sure to align the stack of paper.

? *Do you wish to load a paper size or type different from that previously loaded?*

- For more details on changing the paper size and type, refer to "Loading Paper" on page 4-7.

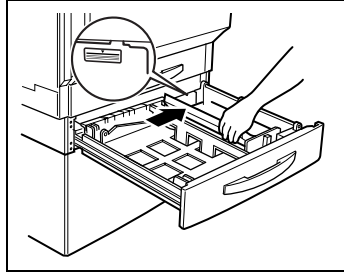

- 4 Slide the lateral guides against the edges of the paper.

- Make sure that the paper is not curled when it is loaded. Check that the lateral guides are pushed up against the edges of the paper.

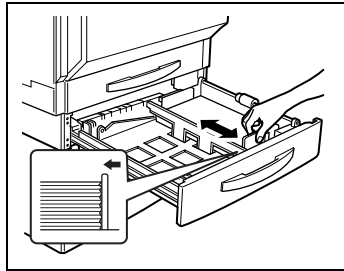

- 5 Close the paper drawer.

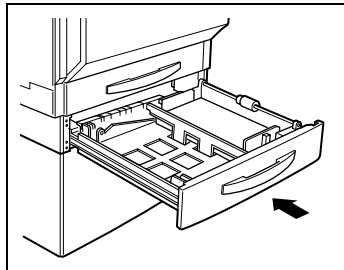

To load paper into the large-capacity cabinet

- 1 Pull out the paper drawer.

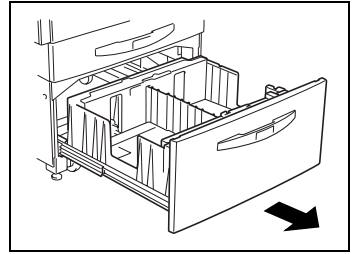

- 2 Load paper into the right side of the drawer so that the front side of the paper (the side facing up when the package was unwrapped) faces up.

? *Have you loaded too much paper into the drawer?*

- Do not load so much paper that the top of the stack is higher than the ▼ mark.

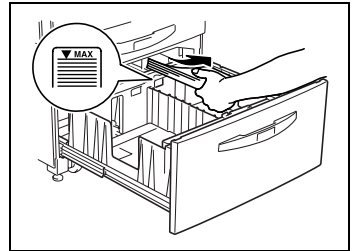

- 3 Load paper into the left side of the drawer so that the front side of the paper (the side facing up when the package was unwrapped) faces up.

? *Have you loaded too much paper into the drawer?*

- Do not load so much paper that the top of the stack is higher than the ▼ mark.

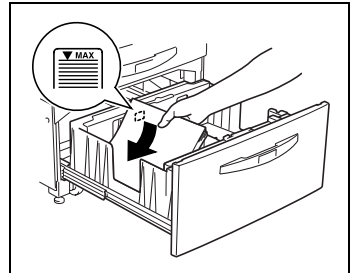

- 4 Close the paper drawer.

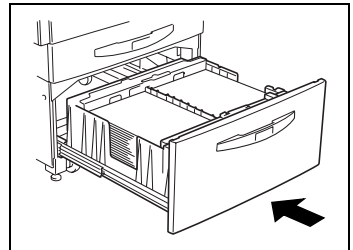

5.2 When the Message “Xxxx toner nearly empty” Appears



Note

Do not refill the toner until the message indicating that “Xxxx toner nearly empty” appears on the control panel display. In addition, do not refill the toner of any color other than the one indicated in the message on the control panel.



CAUTION

Be careful not to spill toner inside the printer or get toner on your clothes or hands.

- If toner gets on your hands, wash them using water and a neutral soap.
 - If toner gets in your eyes, immediately rinse them, and then consult a medical professional.
-



CAUTION

Precaution for the disposal of the used toner bottle

- Do not throw away the used toner bottle; instead, keep it to be collected by your technical representative.
-



WARNING

Precautions for handling toner and the toner bottle:

- Do not throw toner or the toner bottle into a fire. Toner expelled from the fire may cause burns.
-

To add toner

- 1 Open the toner supply door, and then open the toner hopper lid for the toner that you wish to refill.
 - For example: If the yellow toner is empty, open the leftmost toner hopper lid.

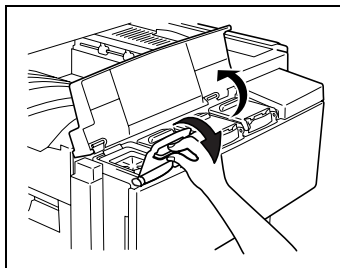

- 2 With the opening of the new toner bottle pointing up, hit the bottom of the bottle against a strong surface, such as a desk or table, four or five times from a height of about 4 in. (10 cm). (Since the toner within the bottle may have become compacted, be sure to break it up by performing this step.)

? *Is the toner bottle being held correctly?*

- When hitting the toner bottle against a surface, be sure to hold the bottle so that the opening of the bottle is pointing up.

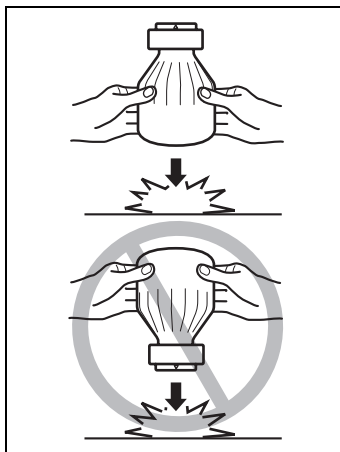

- 3 While firmly grasping the new toner bottle, shake it well.

? *Is the toner within the bottle hard?*

- The toner within the bottle may become compacted. If it does, be sure to shake the bottle until the toner is mostly broken up before adding it to the hopper.

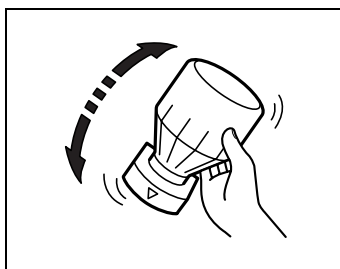

- 4 With the rounded side (marked with “▼”) of the bottle mouth facing towards you, place the toner bottle on top of the hopper, and then press down on the bottle until it snaps into place.

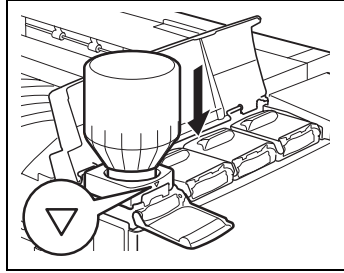

- 5 Fully pull the toner hopper shutter out toward you.
- Pulling out the toner hopper shutter allows the toner to fill the toner hopper.
- Check that all of the toner has emptied out of the toner bottle and into the hopper, which may take a while.

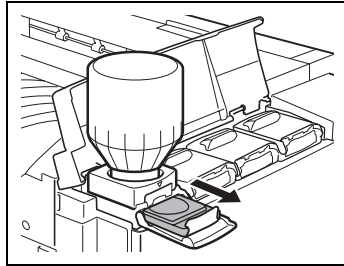

? *Do you know what precautions should be taken when refilling the toner?*

- Do not tap on the toner bottle while refilling the hopper; otherwise, the toner may spurt out.

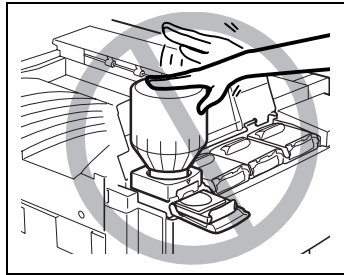

- 6 Push the toner hopper shutter closed.

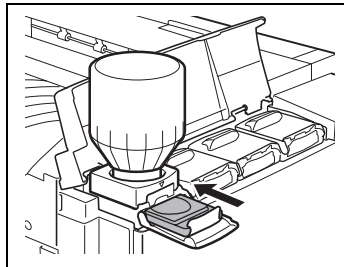

- 7 Tilt the toner bottle backward, and then pull the opening of the bottle up and toward you to remove it.

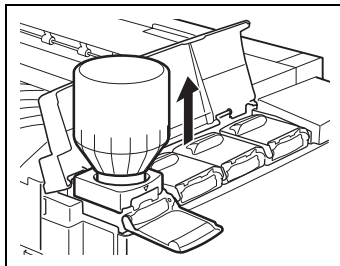

- 8 Close the toner hopper lid, and then close the toner supply door.

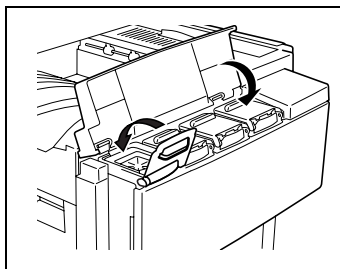

5.3 When the Message “No xxxx staples” Appears



Note

Be sure to replace the staple cartridge only after the message “No xxxx staples” appears. Injuries may occur if the staple cartridge is removed before the message appears.

To replace the staple cartridge

- 1 Slide the finisher away from the printer.

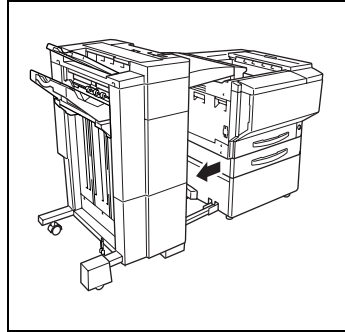

- 2 If finisher FN-107 is installed, open right-side door FN7.

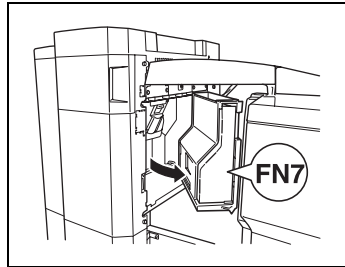

- 3 Turn the dial to the left in order to position the stapler at the center.

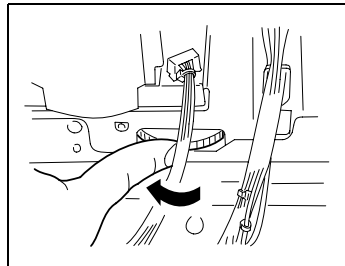

4 Pull the staple holder out toward you.

- Finisher FN-107

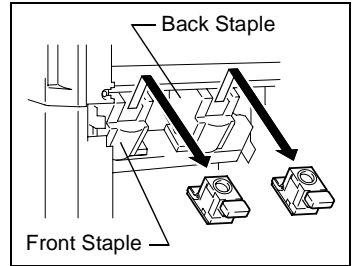

- Finisher FN-108

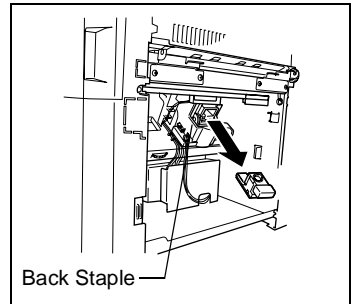

? *Since finisher FN-107 is equipped with two staple holders, which staple holder should be pulled out?*

→ The message on the control panel indicates which staple holder should be pulled out.

- 5** (Finisher FN-107)
Remove the empty staple cartridge from the staple holder.

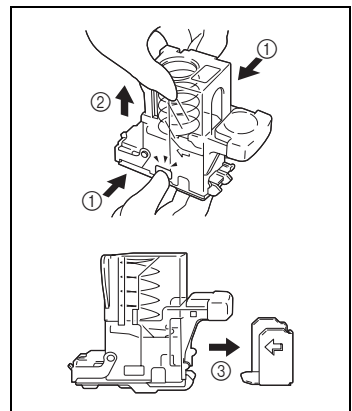

- 6 (Finisher FN-107)
Insert the new staple cartridge into the staple holder, and then carefully remove the stopper.

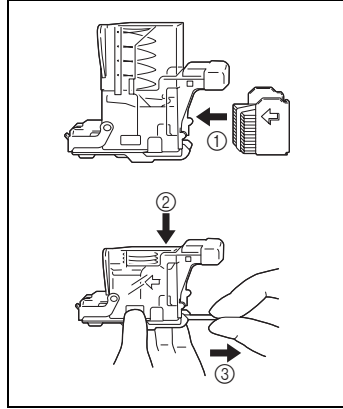

- 7 (Finisher FN-108)
Remove the empty staple cartridge from the staple holder.

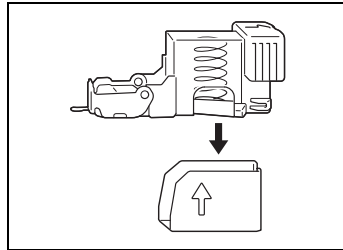

- 8 (Finisher FN-108)
Insert the new staple cartridge into the staple holder, and then carefully remove the stopper.

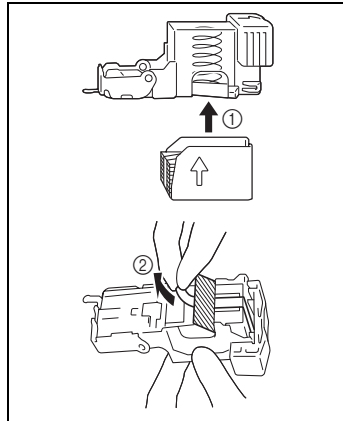

9 Insert the refilled staple holder until it locks into place.

- Finisher FN-107

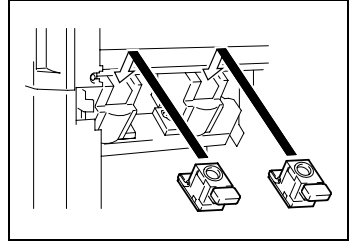

- Finisher FN-108

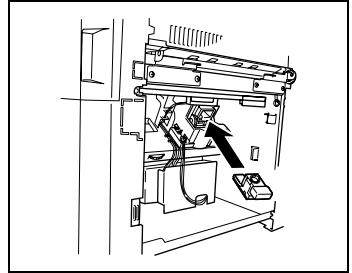

10 If finisher FN-107 is installed, close right-side door FN7.

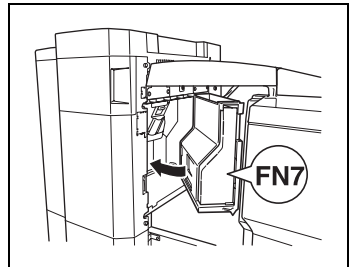

11 Slide the finisher back against the printer.

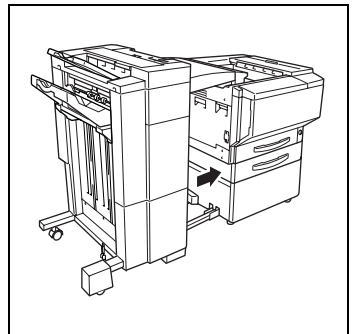

5.4 Clearing a Paper Misfeed and Staple Jam

If a paper misfeed or a staple jam occurs during printing, the message shown below appears.

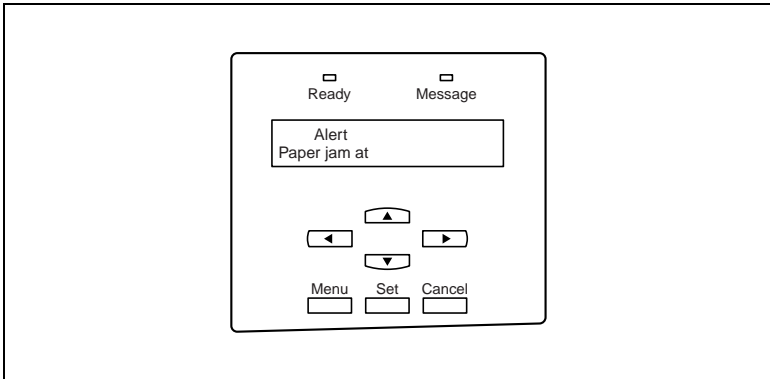

Press ▼ once and check where the paper misfeed occurred.

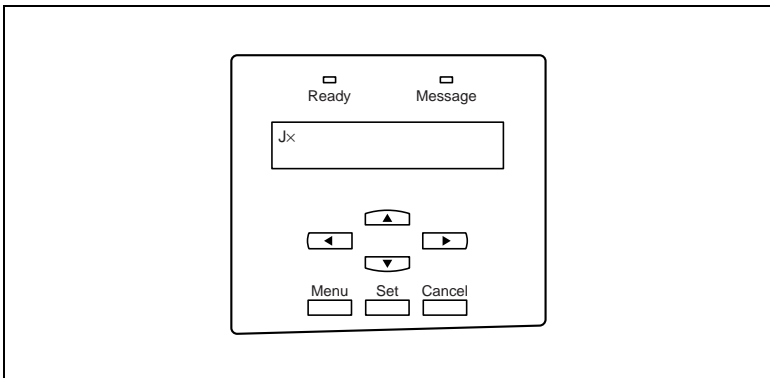

Follow the procedure below to clear the misfed paper or the jammed staples.

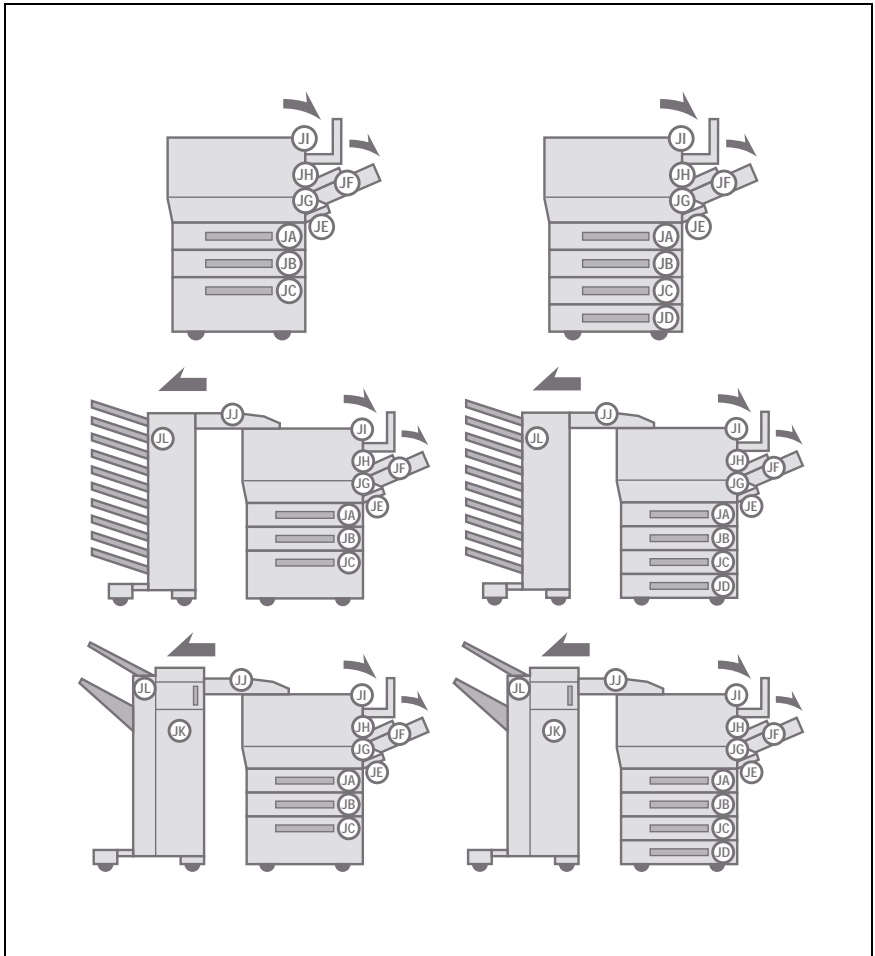

Message	Description	Message	Description
JA	Paper drawers p. 5-21	JB	Paper drawers p. 5-21
JC	Paper drawers p. 5-21	JD	Paper drawers p. 5-21
JE	Manual bypass tray p. 5-18	JF	Duplex unit p. 5-20
JG	Printer p. 5-23	JH	Printer p. 5-23
JI	Printer p. 5-23	JJ	Finisher FN-107/FN108 p. 5-26 10-mailbin sorter p. 5-30
JK	Finisher FN-107/FN108 p. 5-26 10-mailbin sorter p. 5-30	JL	Finisher FN-107/FN108 p. 5-26 10-mailbin sorter p. 5-30

To clear a paper misfeed in the manual bypass tray



CAUTION

Decreased print quality may result if the surface of the image transfer belt at the bottom of the printer's fusing unit is touched.

- Be careful not to touch the surface of the image transfer belt at the bottom of the printer's fusing unit.

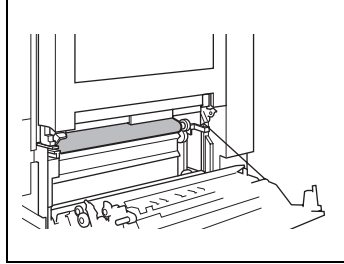

- 1 Pull up the lock release lever to open the right-side door.

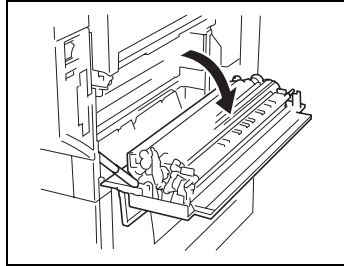

- 2 Carefully pull out the paper.

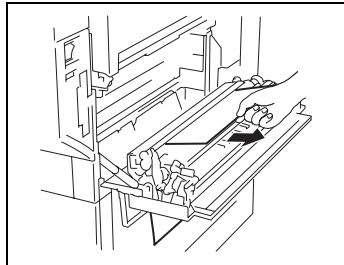

- 3 Close the right-side door.

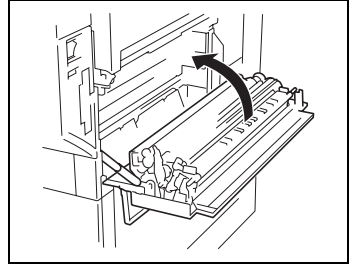

To clear a paper misfeed in the duplex unit

- 1 Open the duplex unit door.

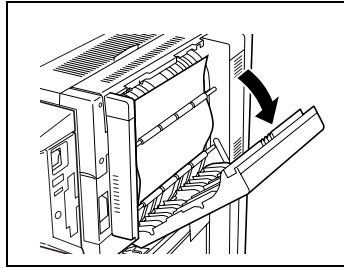

- 2 Carefully pull out the paper.

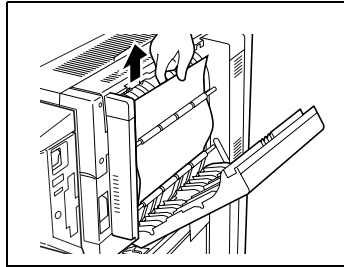

- 3 Close the duplex unit door.

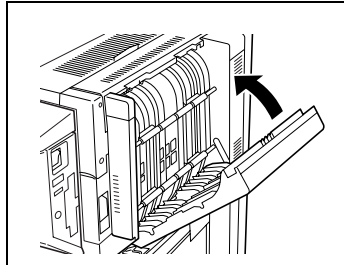

To clear a paper misfeed in the paper feed unit

- 1 Open the lower right-side door.

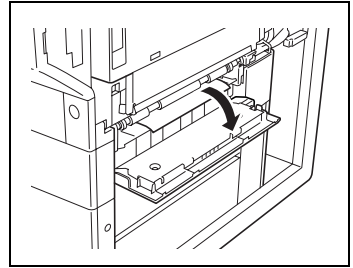

- 2 Turn the green wheels to feed the paper so that it can be easily removed.

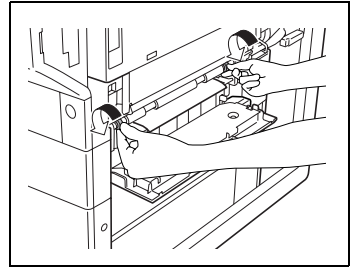

- 3 Carefully pull out the paper.

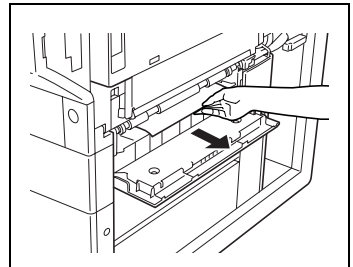

? *Is the large-capacity cabinet installed?*

- While turning the green dial in the direction of the arrow, carefully pull out the paper.

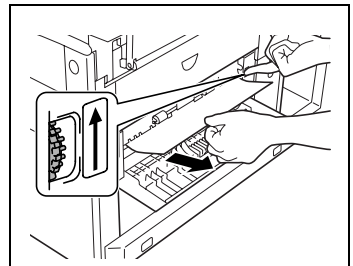

- 4 Close the lower right-side door.
- 5 Pull out the paper drawer being used, and then remove any paper remaining in the drawer.

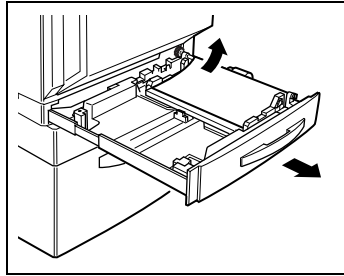

- 6 Load the paper in the drawer again, and then close the drawer.

? *Has the paper take-up roller been touched?*

- Be careful not to touch the surface of the paper take-up roller with your hands. If the roller has been touched, wipe it with a dry cloth.

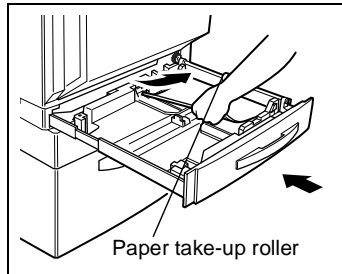

To clear a paper misfeed in the printer**CAUTION**

Decreased print quality may result if the surface of the image transfer belt at the bottom of the printer's fusing unit is touched.

- Be careful not to touch the surface of the image transfer belt at the bottom of the printer's fusing unit.

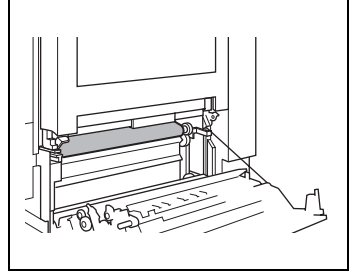
**CAUTION**

The area around the fusing unit is extremely hot.

- Touching anything other than the paper within the area around the fusing unit may result in burns.
- If you get burnt, immediately cool the skin under cold water, and then seek professional medical advice.

- 1 Pull up the lock release lever to open the right-side door.

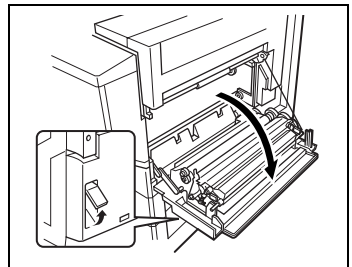

- 2 Grasp the upper right-side door as shown, and then carefully open the door completely while making sure to support it.

? *Is the upper right-side door being opened correctly?*

- Be sure to support the door while carefully opening it; otherwise, it may be damaged.

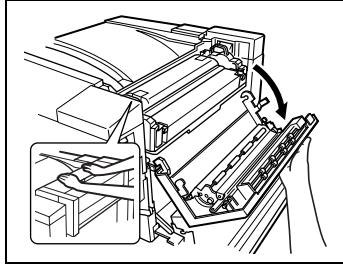

- 3 While moving the green lever on the inside of the upper right-side door in the direction of the arrow, carefully pull out the paper.



- 4 Carefully pull out the paper.

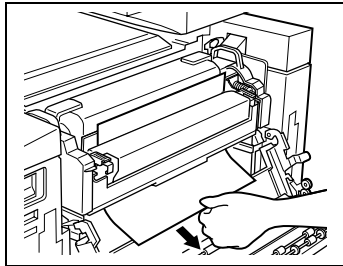

- 5 Move the two lock release levers for the oil-coating unit in the direction of the arrows.

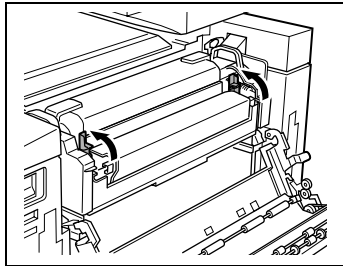

- 6 Move the levers (one on each end of the oil-coating unit) in the direction of the arrows and carefully pull out the paper.

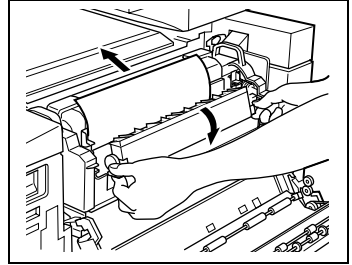

- 7 While holding the levers on the ends of the oil-coating unit, move the unit back to its original position.

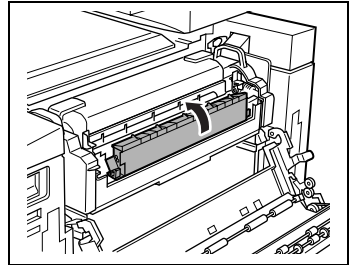

- 8 Fully move the two lock release levers for the oil-coating unit in the direction of the arrows.

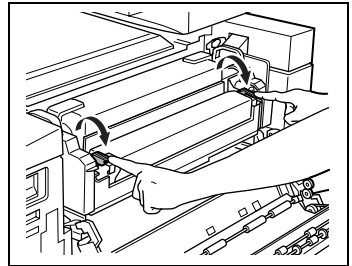

- 9 Close the upper right-side door.

- 10 Close the right-side door.



CAUTION

The area around the fusing unit is extremely hot.

- Touching anything other than the indicated levers around the fusing unit may result in burns.
- If you get burnt, immediately cool the skin under cold water, and then seek professional medical advice.

To clear a paper misfeed in finisher FN-107/FN-108**CAUTION**

Metallic parts inside Misfeed Clearing Guide [FN1] are very hot. (Part indicated in Step 10.)

- Do not touch anything but the paper to prevent you from getting burned.

- 1 Slide the finisher away from the printer.

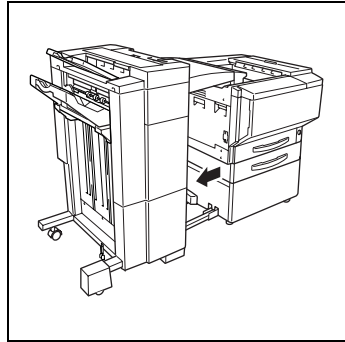

- 2 Open the cover of the horizontal transport unit.

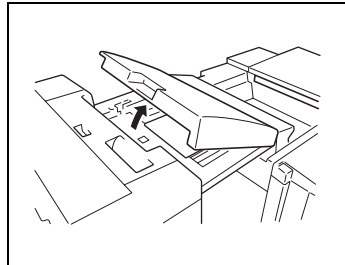

- 3 Remove any paper, and then close the cover of the horizontal transport unit.

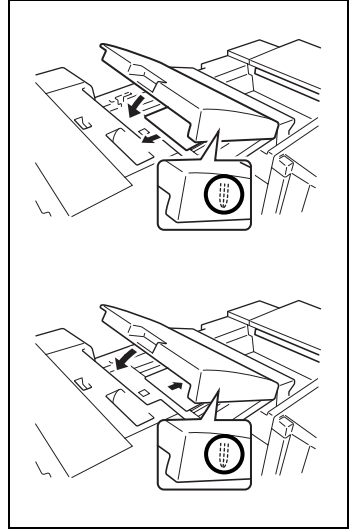

- 4 If finisher FN-107 is installed, open right-side door FN7.

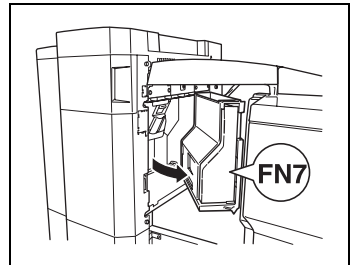

- 5 While holding open misfeed clearing guide FN8 (for finisher FN-107) or FN7 (for finisher FN-108), remove any paper.

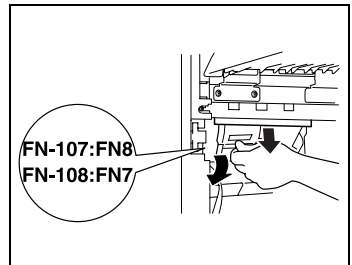

- 6 If finisher FN-107 is installed, close right-side door FN7.
- 7 Open front door FN4.

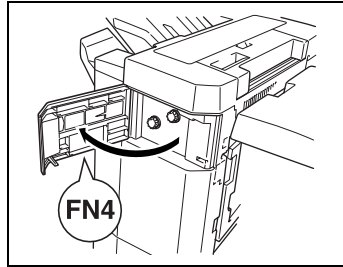

- 8 Turn knobs FN5 at the same time to feed out any paper.

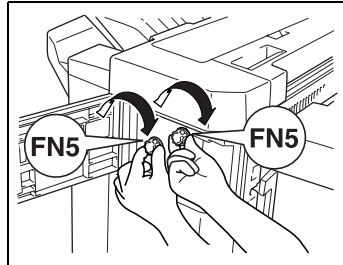

- 9 Close front door FN4.

- 10 Open upper cover FN1.

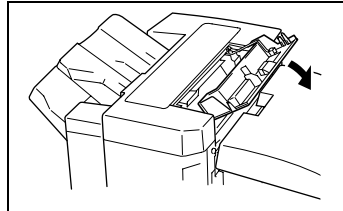

- 11 While holding misfeed clearing guide FN2 open, remove any paper.

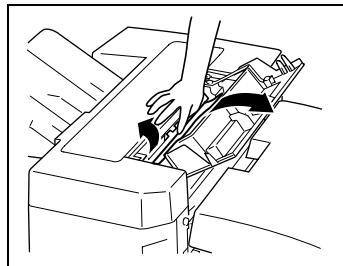

- 12 While holding misfeed clearing guide FN3 open, remove any paper.

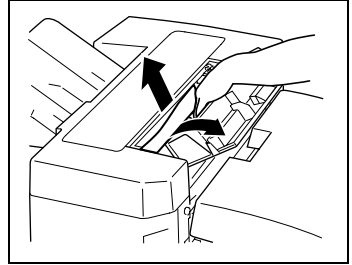

- 13 Close upper cover FN1.

- 14 While holding misfeed clearing guide FN6 open, remove any paper.

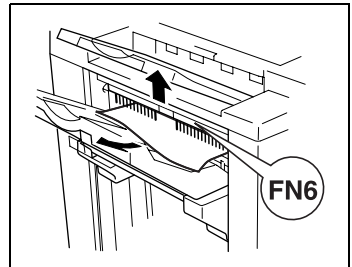

- 15 Slide the finisher back against the printer.

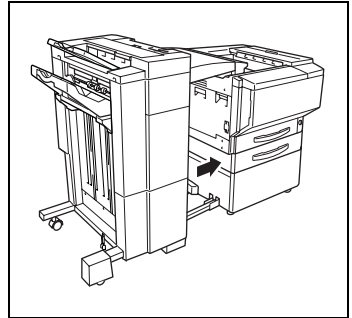

Note

Be careful about a protrusion on the backside of the horizontal transport unit cover.

It can hurt you! (Part indicated in Step3.)

To clear a paper misfeed in the 10-mailbin sorter

- 1 Slide the 10-mailbin sorter away from the printer.

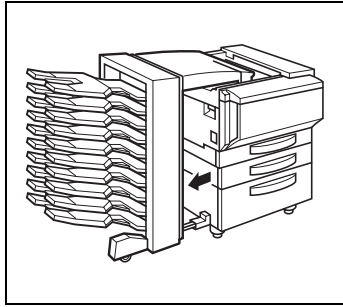

- 2 Remove any paper from the mailbins.

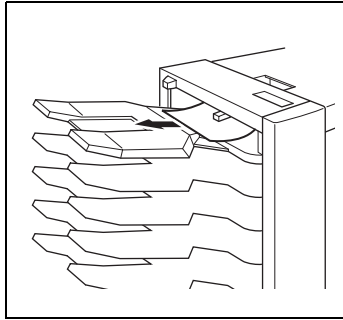

- 3 Open the cover of the horizontal transport unit.

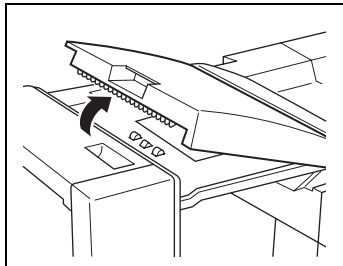

- 4 Remove any paper, and then close the cover of the horizontal transport unit.

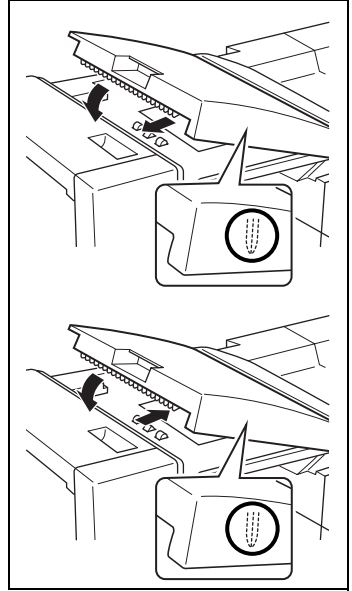

- 5 Open the upper door and the lower door.

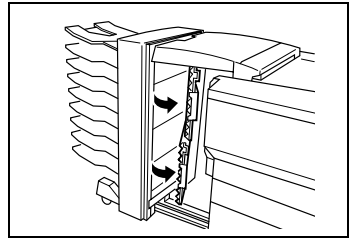

- 6 Remove any paper.

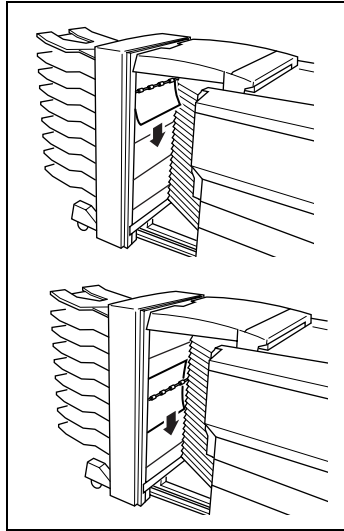

- 7 Close the upper door and the lower door.

- 8 Slide the 10-mailbin sorter back against the printer.

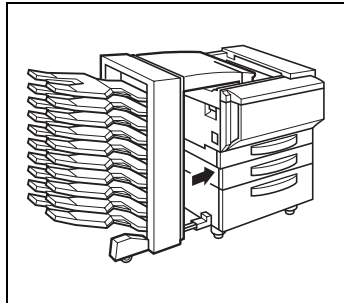

Note

Be careful about a protrusion on the backside of the horizontal transport unit cover.

It can hurt you! (Part indicated in Step 4.)

To clear jammed staples

- 1 Slide the finisher away from the printer.

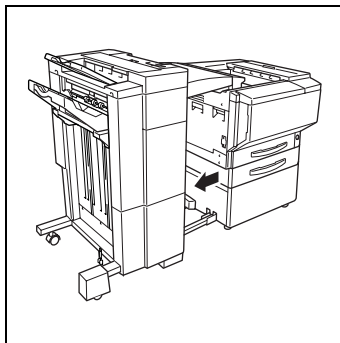

- 2 If finisher FN-107 is installed, open right-side door FN7.

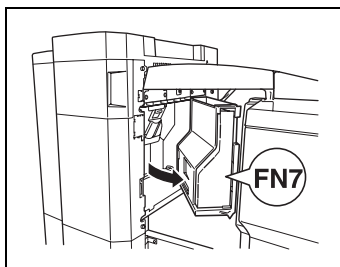

- 3 Turn the dial to the left in order to position the stapler at the center.

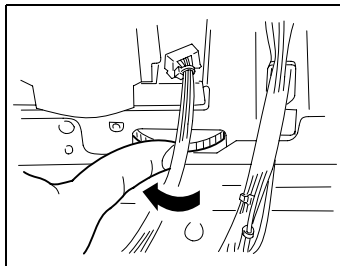

4 Pull the staple holder out toward you.

- Finisher FN-107

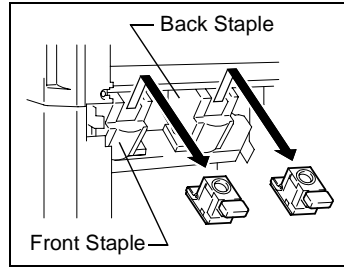

- Finisher FN-108

? *Since finisher FN-107 is equipped with two staple holders, which staple holder should be pulled out?*

- The message on the control panel indicates which staple holder should be pulled out.

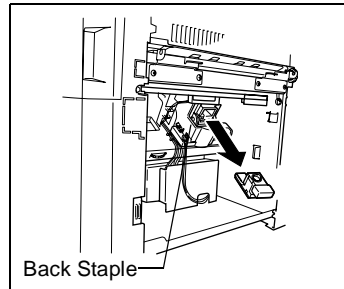

5 Push the staple holder guide up, and then pull out one sheet of staples.

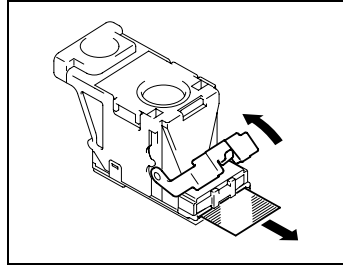

6 Move the guide back to its original position.

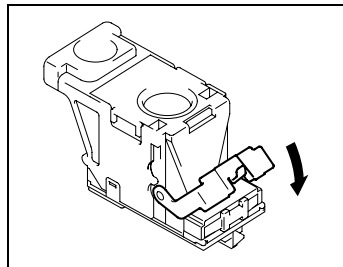

7 Insert the staple holder until it locks into place.

- Finisher FN-107

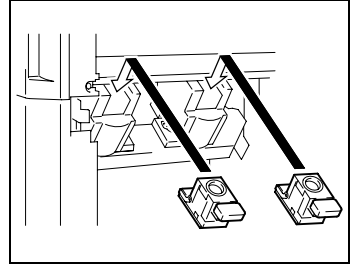

- Finisher FN-108

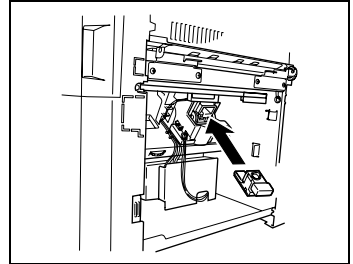

8 If finisher FN-107 is installed, close right-side door FN7.

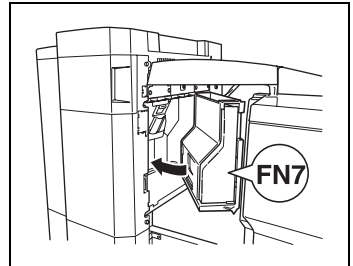

9 Slide the finisher back against the printer.

- ? *Are the staples still jammed, even after performing the above procedure?*

- Contact a qualified technical representative.

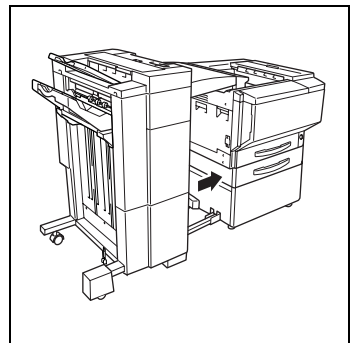

5.5 When the Message “Service Code Cxxxx” Appears

When the message shown below appears in the control panel display, a malfunction has occurred within this printer.

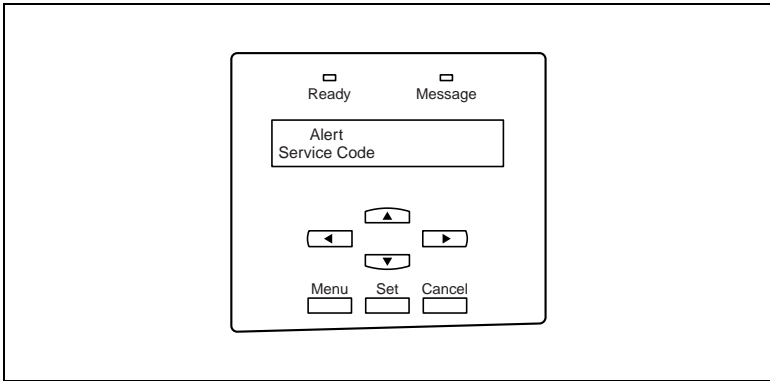

Press ▼ once and check which error code is displayed.

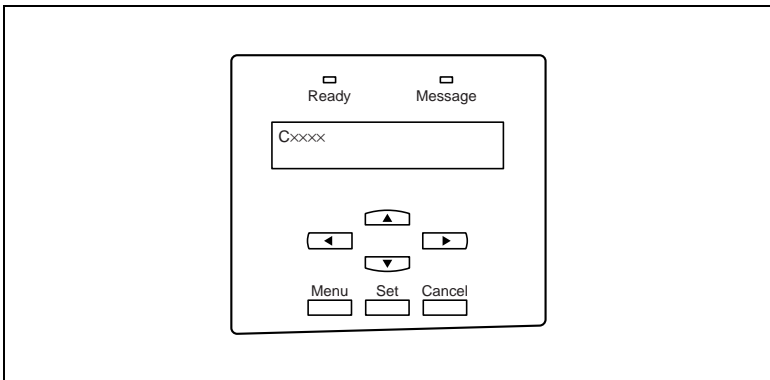

If this message appears, contact your technical representative and inform them of the error code that is indicated.

5.6 When the Message “xxxx unit near life limit” Appears

When it is almost time to replace a unit within this printer, a message like the one shown below appears in the control panel.

When the message appears, replace the unit according to your maintenance agreement.



Note

The display window only displays two lines of a message at one time. To view messages longer than two lines, press ▼ to display the next line of the message.

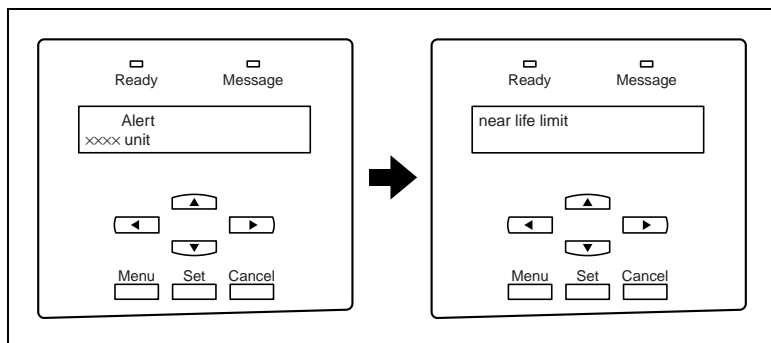

Displayed Messages

- Advance warning message**
 When it is almost time to replace a unit, the message “xxxx unit near life limit” appears in the control panel.
 Prepare the new unit and replace it as soon as possible.
- Replacement warning message**
 After the advance warning message has appeared, about 1,000 printouts can be made before the printer stops operating. (The number of printouts depends on the selected print settings and the unit.) In addition, the message “xxxx unit over life limit xxxx” appears in the control panel followed by instructions for replacing the unit.
 Replace the unit according to the instructions that appear.



Disposing of Used Parts

Dispose of used units according to your local regulations, or contact your technical representative.

5.7 When the Message “Near trouble XX/XX” Appears

When the message shown below appears in the control panel display, image stabilization and printing functions for the printer have become unstable.

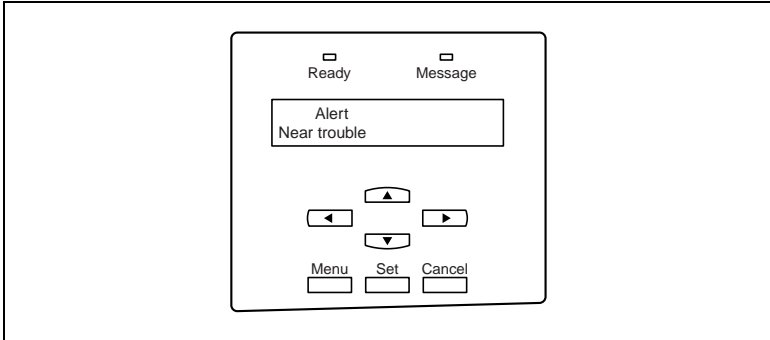

Press ▼ once and click which error code is displayed.

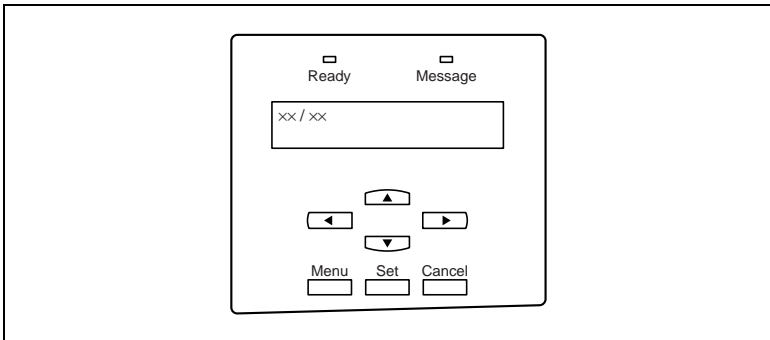



If this message appears, contact your technical representative and inform them of the error code that is indicated.

6 Troubleshooting

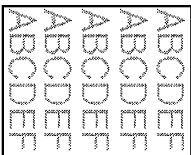
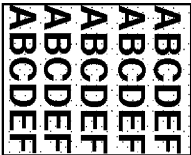
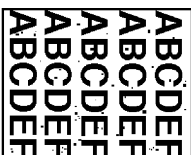
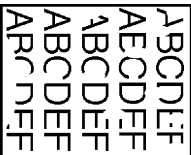
6.1 Improving Print Quality

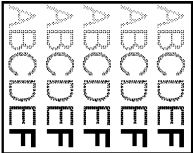
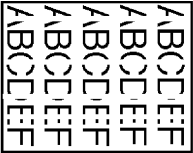
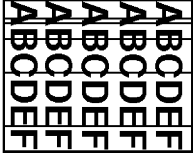
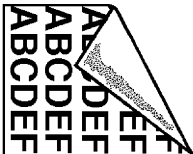
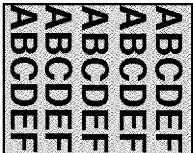
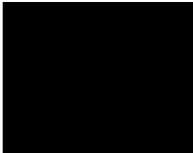
Symptom	Cause	Action
The image is too light. 	The setting in the printer driver is not set properly.	Adjust the setting in the printer driver to the desired level.
	The paper loaded in the tray is damp.	Replace the old paper with fresh dry paper. p. 4-7
	The toner hopper is running out of toner.	Refill the toner. p. 5-8
	The imaging unit may be defective.	Contact your technical representative.
	The image transfer belt unit may be defective.	Contact your technical representative.
The image is too dark. 	The setting in the printer driver is not set properly.	Adjust the setting in the printer driver to the desired level.
	The imaging unit requires replacement.	Contact your technical representative.
	The image transfer belt unit requires replacement.	
The toner smudges. 	The image transfer roller unit requires replacement.	Contact your technical representative.
	The oiling roller requires replacement.	
Partial void image 	The paper loaded in the tray is damp.	Replace the old paper with fresh dry paper.
	The imaging unit requires replacement.	Contact your technical representative.
	The image transfer belt unit requires replacement.	

Symptom	Cause	Action
Inconsistent image density. 	The imaging unit requires replacement.	Contact your technical representative.
	The image transfer belt unit requires replacement.	
White lines. 	The imaging unit requires replacement.	Contact your technical representative.
	The image transfer belt unit requires replacement.	
Black (or color) stripes 	The printer's internal paper path is dirty.	Run several prints to flush out the debris.
	The imaging unit requires replacement.	Contact your technical representative.
	The image transfer roller unit requires replacement.	
Soiled back side 	The printer's internal paper path is dirty.	Run several prints to flush out the debris.
	The oiling roller requires replacement.	Contact your technical representative.
Blurred background 	The imaging unit requires replacement.	Contact your technical representative.
Black pages 	The imaging unit requires replacement.	Contact your technical representative.

Symptom	Cause	Action
Blank pages 	The imaging unit requires replacement.	Contact your technical representative.
Paper wrinkles during printing.	The paper being used is not compatible with the printer.	See "4.1 Paper Specifications" for compatible types of paper. p. 4-1
	Paper is not loaded properly in the tray.	See "4.4 Loading Paper". p. 4-7
	The fusing unit requires replacement.	Contact your technical representative.
The print image is not fixed and easily smears.	The paper loaded in the tray is damp.	Replace the old paper with fresh dry paper.
	The paper being used is not compatible with the printer.	See "4.1 Paper Specifications" for compatible types of paper. p. 4-1
	The fusing unit requires replacement.	Contact your technical representative.
The printer takes too long to output prints.	The printer was in Energy Saver mode when the print command was issued.	If you do not want to use this mode, disable it. Contact your technical representative.
	The printer setting was for color transparency (transparency sheet) or thick paper printing.	Wait a few moments.

7 Appendix

7.1 Specifications

Printer CF2001P

Specification	
Type	Desktop
Photo conductor	OPC
Printing system	Digital Full-Color Printing
Developing system	NMT(New Micro-toning) system
Fusing system	Belt-fixing
Resolution	600 dpi × 600 dpi
Paper types	Standard paper (17.02 to 23.94 lbs.(64 to 90 g/m ²)), thick paper 1 ^{*1} (24.21 to 43.36 lbs.(91 to 163 g/m ²)), thick paper 2 ^{*2} (43.62 to 55.59 lbs.(164 to 209 g/m ²)), overhead projector transparencies ^{*1} , postcards ^{*1} ^{*1} : Can only be fed through Tray 1. ^{*2} : Thick paper 2 can be used for only postcards sizes.
Paper sizes	<ul style="list-style-type: none"> • Tray 1 12.25 × 18L^{*1}, 11 × 17L, 11 × 14L, LegalL, LetterL, LetterC, ExecutiveL, ExecutiveC, 5.5 × 8.5L, 5.5 × 8.5C, 4 × 6L^{*1}, A3WideL^{*2}, A3L, A4L, A4C, A5L, A5C, A6L^{*2} • Tray 2/500-sheet paper feed unit 11 × 17L, 11 × 14L, LegalL, LetterL, LetterC, A3L, A4L, A4C • Manual bypass tray^{*3} 12.25 × 18L^{*1}, 11 × 17L, 11 × 14L, LegalL, LetterL, LetterC, ExecutiveL, ExecutiveC, 5.5 × 8.5L, 5.5 × 8.5C, 4 × 6L^{*1}, A3WideL^{*2}, A3L, A4L, A4C, A5L, A5C, A6L^{*2} • Large-capacity cabinet LetterC^{*1}, A4C^{*2} ^{*1} : For US only ^{*2} : For Europe only ^{*3} : MicroPress PrintLink 2020m only
Input capacity	<ul style="list-style-type: none"> • Tray 1 250 sheets (when using 21.28 lbs.(80 g/m²) standard paper) • Tray 2/500-sheet paper feed unit 500 sheets (when using 21.28 lbs.(80 g/m²) standard paper) • Manual bypass tray 1 sheet (standard paper, thick paper 1, thick paper 2, overhead projector transparencies, or postcard) • Large-capacity cabinet 2500 sheets (when using 21.28 lbs.(80 g/m²) standard paper) ^{*1} : MicroPress PrintLink 2020m only
Output capacity	250 sheets (standard paper)
Warm-up time	Less than 5 minutes at room temperature (68°F/20°C)

Specification	
First print	Full color: Less than 15 seconds Black: Less than 12 seconds
Print speed	Full color/Black: LetterC/A4C: 20 sheets/min. LetterL/A4L: 14 sheets/min. A3L/11 x 17L: 10 sheets/min.
Memory	304 MB
Power Requirements	US: 110/120/127 V; 15 A, 60 Hz, Europe: 220–240 V; 10 A, 50/60 Hz
Power consumption	US: Less than 1.3 kW Europe: Less than 1.5 kW
Dimensions	W: 23.46 in. (596 mm) D: 28.74 in. (730 mm) H: 20.59 in. (523 mm)
Space requirements	W: 25.28 in. (642 mm) D: 28.74 in. (730 mm)
Weight	187.39 lbs. (85 kg) (with one 500-sheet paper feed unit and all four imaging units installed)

500-sheet Paper Feed Unit PF-118

Specification	
Paper types	Standard paper (17.02 to 23.94 lbs. (64 to 90 g/m ²))
Paper sizes	11 x 17L, 11 x 14L, LegalL, LetterL, LetterC, A3L, A4L, A4C
Capacity	500 sheets (21.28 lbs. (80 g/m ²))
Power source	Supplied from printer
Power consumption	Less than 9 W
Dimensions	W: 21.06 in. (535 mm) D: 22.36 in. (568 mm) H: 5.39 in. (137 mm)
Weight	About 18.75 lbs. (8.5 kg)

Large-capacity Cabinet PF-117

Specification	
Paper types	Standard paper (17.02 to 23.94 lbs. (64 to 90 g/m ²))
Paper sizes	US: LetterC Europe: A4C
Capacity	2500 sheets (21.28 lbs. (80 g/m ²))
Power source	Supplied from printer
Power consumption	Less than 45 W
Dimensions	W: 21.06 in. (535 mm) D: 22.36 in. (568 mm) H: 11.18 in. (284 mm)
Weight	About 36.82 lbs. (16.7 kg)

Duplex Unit AD-14

Specification	
Paper types	Standard paper (17.02 to 23.94 lbs. (64 to 90 g/m ²))
Paper sizes	12.25 × 18L ^{*1} , 11 × 17L, 11 × 14L, LegalL, LetterL, LetterC, ExecutiveL, ExecutiveC, 5.5 × 8.5L, A3WideL ^{*2} , A3L, A4L, A4C, A5L ^{*1} : For US only ^{*2} : For Europe only
Power source	Supplied from printer
Power consumption	Less than 17 W
Dimensions	W: 5.47 in. (139 mm) D: 17.32 in. (440 mm) H: 14.37 in. (365 mm)
Weight	About 6.38 lbs.(3.1 kg)

10-Mailbin Sorter JS-1002

Specification	
No. of bins	10
Paper types	<ul style="list-style-type: none"> Bin 1: Standard paper (17.02 to 23.94 lbs. (64 to 90 g/m²)), thick paper (24.21 to 55.59 lbs. (91 to 209 g/m²)), overhead projector transparencies, postcards Bin 2 to Bin 10: Standard paper (17.02 to 23.94 lbs. (64 to 90 g/m²))
Paper sizes	<ul style="list-style-type: none"> Bin 1: 12.25 x 18L^{*1}, 11 x 17L, 11 x 14L, LegalL, LetterL, LetterC, ExecutiveL, ExecutiveC, 5.5 x 8.5L, 5.5 x 8.5C, 4 x 6L^{*1}, A3WideL^{*2}, A3L, A4L, A4C, A5L, A5C, A6L^{*2} ^{*1}: For US only ^{*2}: For Europe only Bin 2 to Bin 10: 11 x 17L, 11 x 14L, LegalL, LetterL, LetterC, ExecutiveL, ExecutiveC, 5.5 x 8.5L, A3L, A4L, A4C, A5L
Capacity of bins	<ul style="list-style-type: none"> Bin 1: Standard paper (21.28 lbs. (80 g/m²)): Maximum 200 sheets Thick paper (24.21 to 55.59 lbs.(91 to 209 g/m²)): Maximum 20 sheets Overhead projector transparencies: Maximum 1 sheet Postcards: Maximum 20 sheets Bin 2 to Bin 10: Standard paper (21.28 lbs.(80 g/m²)): Maximum 200 sheets/bin Total: 2,000 sheets
Power source	Supplied from printer
Power consumption	Less than 32 W
Dimensions	W: 21.81 in. (554 mm) D: 20.15 in. (512 mm) H: 34.4 in. (874 mm)
Weight	<ul style="list-style-type: none"> Main unit: about 63.93 lbs.(29 kg) Horizontal transport unit: 8.81 lbs.(4 kg)

Finisher FN-107

Specification	
No. of bins	2 (Upper paper output tray, Lower paper output tray)
Paper types	<ul style="list-style-type: none"> Upper paper output tray Standard paper (17.02 to 23.94 lbs. (64 to 90 g/m²)), thick paper (24.21 to 55.59 lbs.(91 to 209 g/m²)), overhead projector transparencies, postcards Lower paper output tray Standard paper (17.02 to 23.94 lbs. (64 to 90 g/m²))
Paper sizes	<ul style="list-style-type: none"> Upper paper output tray 12.25 x 18L^{*1}, 11 x 17L, 11 x 14L, LegalL, LetterL, LetterC, ExecutiveL, ExecutiveC, 5.5 x 8.5L, 5.5 x 8.5C, 4 x 6L^{*1}, A3WideL^{*2}, A3L, A4L, A4C, A5L, A5C, A6L^{*2} Lower paper output tray 12.25 x 18L^{*1}, 11 x 17L, 11 x 14L, LegalL, LetterL, LetterC, ExecutiveL, ExecutiveC, A3WideL^{*2}, A3L, A4L, A4C <p>^{*1}: For US only ^{*2}: For Europe only</p>
Capacity of bins	<ul style="list-style-type: none"> Upper paper output tray Standard paper (21.28 lbs. (80 g/m²)): Maximum 250 sheets Thick paper (24.21 to 55.59 lbs. (91 to 209 g/m²)): Maximum 20 sheets Overhead projector transparencies: Maximum 1 sheet Postcards: Maximum 20 sheets Lower paper output tray Standard paper (21.25 lbs. (80 g/m²)): LetterL or smaller maximum 3,000 sheets; LegalL or larger maximum 1,500 sheets
"Staple" setting	<ul style="list-style-type: none"> Corner 11 x 17L, 11 x 14L, LegalL, LetterL, LetterC, ExecutiveL, ExecutiveC, A3L, A4L, A4C Long edge-2 point LetterC, ExecutiveC, A4C Short edge-2 point 11 x 17L, 11 x 14L, A3L
"Punch" setting	<ul style="list-style-type: none"> Long edge 2^{*1}/3 ^{*1}/4 ^{*2} holes LetterC, ExecutiveC, 5.5 x 8.5C, A4C, A5C Short edge 2^{*1}/3 ^{*1}/4 ^{*2} holes 12.25 x 18L^{*1}, 11 x 17L, 11 x 14L, LegalL, LetterL, ExecutiveL, 5.5 x 8.5L, A3WideL^{*2}, A3L, A4L, A5L <p>^{*1}: For US only ^{*2}: For Europe only</p>
Power source	Supplied from printer
Power consumption	Less than 63 W
Dimensions	W: 21.18 in. (538 mm) D: 24.76 in. (629 mm) H: 38.50 in. (978 mm)
Weight	About 86.42 lbs. (39.2 kg)
Accessories	2 staple cartridges (5,000 staples)

Finisher FN-108

Specification	
No. of bins	2 (Upper paper output tray, Lower paper output tray)
Paper types	<ul style="list-style-type: none"> Upper paper output tray Standard paper (17.02 to 23.94 lbs. (64 to 90 g/m²)), thick paper (24.21 to 55.59 lbs.(91 to 209 g/m²)), overhead projector transparencies, postcards Lower paper output tray Standard paper (17.02 to 23.94 lbs. (64 to 90 g/m²))
Paper sizes	<ul style="list-style-type: none"> Upper paper output tray 12.25 x 18L^{*1}, 11 x 17L, 11 x 14L, LegalL, LetterL, LetterC, ExecutiveL, ExecutiveC, 5.5 x 8.5L, 5.5 x 8.5C, 4 x 6L^{*1}, A3WideL^{*2}, A3L, A4L, A4C, A5L, A5C, A6L^{*2} Lower paper output tray 12.25 x 18L^{*1}, 11 x 17L, 11 x 14L, LegalL, LetterL, LetterC, ExecutiveL, ExecutiveC, A3WideL^{*2}, A3L, A4L, A4C <p>^{*1}: For US only ^{*2}: For Europe only</p>
Capacity of bins	<ul style="list-style-type: none"> Upper paper output tray Standard paper (21.28 lbs. (80 g/m²)): Maximum 250 sheets Thick paper: Maximum 20 sheets Overhead projector transparencies: Maximum 1 sheet Postcards: Maximum 20 sheets Lower paper output tray Standard paper (21.25 lbs. (80 g/m²)): LetterL or smaller maximum 1,000 sheets; LegalL or larger maximum 500 sheets
“Staple” setting	<ul style="list-style-type: none"> Corner 11 x 17L, 11 x 14L, LegalL, LetterL, LetterC, ExecutiveL, ExecutiveC, A3L, A4L, A4C
Power source	Supplied from printer
Power consumption	Less than 63 W
Dimensions	W: 21.18 in. (538 mm) D: 24.76 in. (629 mm) H: 38.50 in. (978 mm)
Weight	About 86.42 lbs. (39.2 kg)
Accessories	1 staple cartridge (3,000 staples)

7.2 Care of the Printer

Cleaning

- + Turn the printer off before cleaning it.

Housing cover

- Clean the surface of the housing cover by wiping it with a soft cloth dampened with a mild household detergent.

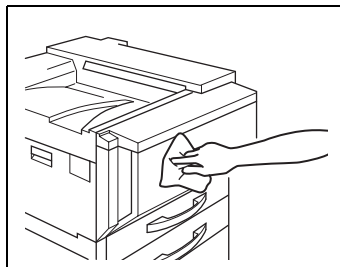

Control panel

- Clean the control panel by wiping it with a soft, dry cloth.

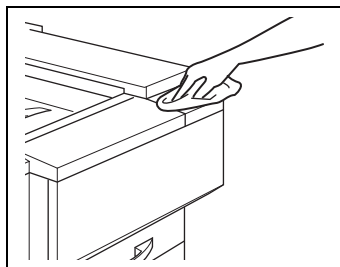

CAUTION

Incorrectly cleaning the control panel may damage them.

- Never use mild household detergent or glass cleaner to clean the control panel.

8 Index

Numerics

10-Mailbin sorter	3-1, 3-9, 7-4
500-sheet Paper Feed Unit	7-2

C

Care of the Printer	7-7
Control panel	3-5
Cancel button	3-13
Display window	3-13
Menu button	3-13
Message light	3-13
Message List	5-1
Right/left buttons	3-13
Set button	3-13
Up/down buttons	3-13
Copy desk	3-3
Copy table	3-3

D

Duplex unit	3-2, 3-8, 7-3
-------------------	---------------

F

Features	1-13
Finisher	3-2, 3-10, 7-5, 7-6
Front door	3-5
Fusing unit	3-7
Fusing web unit	3-7

I

Image transfer belt unit	3-7
Image transfer roller unit	3-7
Imaging unit	3-7
Installation site	2-1

L

Large-capacity cabinet	3-2, 3-12, 7-3
LED cleaning tool	3-7
Left-side door	3-5
Lower right-side door	3-5

M

Manual bypass tray	3-5
Message	
“Near trouble XX/XX” Appears	5-38
“No xxxx staples” Appears	5-12
“Service Code Cxxxx” Appears	5-36
“Xxxx toner nearly empty”	5-8
“xxxx unit near life limit” Appears	5-37
Message List	5-1

O

OHP film	4-4
Oil-coating unit	3-7
Operation precautions	2-3
Options	
10-Mailbin sorter	3-1, 3-9
Copy desk	3-3
Copy table	3-3
Duplex unit	3-2, 3-8
Finisher	3-2, 3-10
Large-capacity cabinet	3-2, 3-12
Paper feed unit	3-2, 3-11
Overhead projector transparencies	4-4
Ozone filter	3-7

P

Paper feed unit	3-2, 3-11
Paper feeding path	1-11
Paper misfeed clearing	5-16
10-mailbin sorter	5-30
Duplex unit	5-20
Finisher	5-26
Manual bypass tray	5-18

Paper feed unit	5-21
Printer	5-23
Paper orientation	1-12
Paper sizes	4-2
Paper types	4-1
Power source	2-1
Power switch	3-5
Print output tray	3-5
Printer	3-1, 7-1
Printer controller Fiery X3e	3-3, 3-12
Printer controller MicroPress PrintLink 2020m	3-3, 3-12

R

Right-side door	3-5
Right-side door release lever	3-5

S

Space requirements	2-2
Specifications	7-1
Staple jam clearing	5-16, 5-33

T

To load paper into the large-capacity cabinet	4-14
To load paper into the manual bypass tray	4-16
To load paper into Tray 1 (250-sheet multipurpose tray)	4-7
To load paper into Tray 2 or the 500-sheet paper feed unit	4-12
To print the total counter	3-18
Toner hopper lid	3-6
Toner supply door	3-5
Tray 1	3-5
Tray 2	3-5
Troubleshooting	6-1
Turning the printer on and off	3-14

U

Upper right-side door	3-6
-----------------------------	-----

W

Waste toner bottle 3-7



MINOLTA

Copyright

2001 MINOLTA CO., LTD.

The information contained in this manual is subject to change without notice to incorporate improvements made on the product or products the manual covers.

MINOLTA CO., LTD.

3-13, 2-Chome, Azuchi-Machi, Chuo-ku, Osaka 541-8556, Japan